

AMADEUS SERVICE MANUAL

Order-No. 610 221

Software Versions: 30, 31, 32, 33

published by

HAMILTON MEDICAL AG

Technical Support
Via Nova
CH-7403 Rhäzüns

Switzerland

Phone +41 81 37 26 27
Fax +41 81 37 26 89

© 28. 2.1994

TABLE OF CONTENTS

ACTUAL MANUAL VERSION	III
PREFACE	IV
LIST OF ABBREVIATIONS	IX
LANGUAGES ON THE FRONTPANEL	X
SECTION OVERVIEW	XIII

1 AMADEUS CONCEPT & BASIC PRINCIPLES

1.3 PARTS LIST

2 ALARM SYSTEM

3 POWER SUPPLY

4 MOTHERBOARD

5 FRONT PANEL PROCESSING

6 CONTROL PROCESSING

7 VALVE CONTROL

8 MIXER, O₂ AND FLOW BOARD

9 SUPERVISOR BOARD

10 PNEUMATIC OF THE AMADEUS

11 TESTSOFTWARE

12 OPTIONS

13 SWITCH SETTINGS

14 MODIFICATION

15 SOFTWARE OVERVIEW

ACTUAL VERSION

VERSION	CHANGES	CHANGED PAGE	NEW PAGE	DATE OF RELEASE
	First Edition			10.02.89
01	Upgrade Version 31	Several	Several	1.12.89
02	Upgrade Version 32	Non	2/3 2/3.1 11/3 11/4 11/11 11/31 11/31/1 Optional Switches (4 pages)	01.12.90
03	Modification	Several	11/3 11/4	12.01.93
04	New Edition Version 33			28.02.94

PREFACE

PROPRIETARY INFORMATION

INFORMATION CONTAINED WITHIN THIS SERVICE MANUAL IS PROPRIETARY TO HAMILTON MEDICAL AG, AND MAY BE USED ONLY FOR THE PURPOSE OF PROVIDING MAINTENANCE. THE PURCHASE, RECEIPT OR POSSESSION OF THIS SERVICE MANUAL DOES NOT CONFER, TRANSFER OR LICENSE ANY OTHER RIGHTS IN THIS INFORMATION. ANY OTHER USE OR DISCLOSURE AND/OR REPRODUCTION, BY ANY METHOD, OF THE INFORMATION CONTAINED HEREIN IS PROHIBITED UNLESS EXPRESSLY PERMITTED.

INTRODUCTION

The HAMILTON MEDICAL Ventilator Service Manual contains electrical and mechanical verification, calibration, trouble-shooting and replacement instructions prepared to assist a qualified biomedical technician in the maintenance of the ventilator.

The Service Manual is specifically intended for use by an authorized service person. Any adjustments or procedures that exceed the scope of this manual should be referred to HAMILTON MEDICAL AG or your local HAMILTON MEDICAL representative. For specific operating instructions and clinical theory of operation, refer to the HAMILTON MEDICAL OPERATOR'S MANUAL. Maintenance personnel should become thoroughly familiar with the operation of the AMADEUS and must have participated in a HAMILTON MEDICAL SERVICE TRAINING Course before servicing this equipment.

EXPLANATION

Each section heading in this Service Manual, contains the following information:

Example:

SECTION 2	ALARM SYSTEM	Used with marked Software Version				
		30	31	32	33	

SECTION 2 : Number of the section

ALARM SYSTEM : Topic of the section

Used with marked Software Version				
30	31	32	33	

These numbers are the Software Versions currently being used with the AMADEUS.

The marked number(s) indicate that the information on the page is for that Software Version(s) only.

HAMILTON MEDICAL AG STANDARD WARRANTY

HAMILTON MEDICAL AG (Inc), through its Official Distributor, warrants this product to be free from defects in construction, material and workmanship for a period of twelve (12) months from the date of original delivery to the purchaser when operated properly under conditions of normal use for which the product is intended. This twelve (12) month warranty does not extend to expendable items such as membranes, hoses and filters which are warranted to be free of defects only at the time of original delivery.

The official HAMILTON MEDICAL AG (Inc) distributor will, at its option, either repair or replace any defective product, as defined above, which is reported to that HAMILTON MEDICAL AG (Inc) Distributor within 72 hours of occurrence during the warranty period. If so instructed by the Distributor, such defective products must be returned to the Official HAMILTON MEDICAL AG (Inc) Distributor in **THE ORIGINAL CONTAINER** with freight charges prepaid. In any case, HAMILTON MEDICAL AG (Inc) shall be responsible for repairs to, or replacement of, such defective product only.

LIMITATIONS ON AND DISCLAIMER OF WARRANTIES:

HAMILTON MEDICAL AG (Inc) shall be relieved of any liability under this warranty if: the product is not used in accordance with the manufacturer's instructions; if regular periodic maintenance and service is not performed; if repairs are made by other than authorized HAMILTON MEDICAL AG (Inc) service personnel; if the product has been subject to abuse, misuse, negligence or accident. Any product that has been mechanically or electronically altered without specific written authorization from HAMILTON MEDICAL AG (Inc) is also excluded from this warranty.

The warranty described in this Agreement is in lieu of all other warranties. **THE PARTIES AGREE THAT THE IMPLIED WARRANTIES OF MERCHANTABILITY AND FITNESS FOR A PARTICULAR PURPOSE AND ALL OTHER WARRANTIES, EXPRESS OR IMPLIED, ARE EXCLUDED FROM THIS AGREEMENT.**

Except as stated above, HAMILTON MEDICAL AG (Inc) **SHALL NOT BE LIABLE FOR ANY DAMAGES, CLAIMS OR LIABILITIES INCLUDING, BUT NOT LIMITED TO, PERSONAL BODILY INJURY, OR INCIDENTAL, CONSEQUENTIAL OR SPECIAL DAMAGES.**

WARNINGS AND CAUTIONS

WARNINGS, CAUTIONS AND NOTES DEFINED

WARNING

Indicates there is a possibility of personal injury to yourself or others.

NOTE:

Indicates significant points to be aware of.

CAUTION

Indicates there is a possibility of damage to the instrument or other property.

THE FOLLOWING GENERAL WARNING AND CAUTIONS MUST BE READ AND UNDERSTOOD PRIOR TO PERFORMING ANY OF THE TESTS, REPAIRS OR OTHER PROCEDURES IN THIS SERVICE MANUAL.

GENERAL WARNINGS

UNDER NO CIRCUMSTANCES SHOULD THIS MEDICAL DEVICE BE OPERATED IN THE PRESENCE OF FLAMMABLE ANAESTHETICS OR OTHER VOLATILE MATERIALS DUE TO A POSSIBLE EXPLOSION HAZARD.

LIQUID SPILLED OR DRIPPED INTO THE UNIT MAY CAUSE DAMAGE TO THE UNIT OR RESULT IN AN ELECTRICAL SHOCK HAZARD.

OXYGEN VIGOROUSLY ACCELERATES COMBUSTION. THERE FOR DO NOT USE ANY GAUGES, VALVES OR OTHER EQUIPMENT THAT HAVE BEEN EXPOSED TO OIL OR GREASE CONTAMINATION TO AVOID VIOLENT IGNITION.

DO NOT RELEASE THIS MEDICAL DEVICE IF ANY ALARM/ALERT FUNCTION IS INOPERATIVE. TO DO SO COULD RESULT IN A MALFUNCTION WITHOUT WARNING, POSSIBLY RESULTING IN PERSONAL INJURY OR PROPERTY DAMAGE. REFER THE UNIT TO A HAMILTON MEDICAL AUTHORIZED SERVICE TECHNICIAN OR A HAMILTON MEDICAL TRAINED HOSPITAL SERVICE TECHNICIAN.

ALL TUBING AND FITTINGS USED TO CONNECT HIGH PRESSURE GAS (AIR AND OXYGEN) FROM THE SOURCE TO THE TEST EQUIPMENT AND FROM THE TEST EQUIPMENT TO THE DEVICE TO BE TESTED MUST BE CAPABLE OF WITHSTANDING A MINIMUM SUPPLY PRESSURE OF 100 PSI (7.03 Kg/cm²). THE USE OF TUBING AND FITTINGS NOT CAPABLE OF WITHSTANDING THIS PRESSURE COULD CAUSE THE TUBING TO RUPTURE, RESULTING IN PERSONAL INJURY OR PROPERTY DAMAGE.

WHEN VERIFYING THE OPERATION OF THIS MEDICAL DEVICE, DO NOT BREATHE DIRECTLY FROM THE MACHINE. ALWAYS USE A FRESH BACTERIAL FILTER AND TEST CIRCUIT OTHERWISE A HAZARD TO THE HEALTH OF THE SERVICE PERSON MAY RESULT.

IF ANY OF THE FOLLOWING PROCEDURES CANNOT BE VERIFIED AS OUTLINED IN THIS DOCUMENT, DISCONNECT THIS MEDICAL DEVICE AND REFER IT TO HAMILTON MEDICAL AG, OR A HAMILTON MEDICAL AUTHORIZED SERVICE FACILITY OR A HAMILTON MEDICAL TRAINED HOSPITAL SERVICE TECHNICIAN.

DO NOT DISPOSE OF THE INTERNAL NI-CAD BATTERY BY INCINERATION AS IT MAY EXPLODE WHEN EXPOSED TO A FLAME.

DO NOT ATTEMPT TO CHARGE THE INTERNAL BATTERY WITH ANY OTHER CHARGER THAN THE ONE CONTAINED IN THE VENTILATOR, AS IT MAY EXPLODE OR DAMAGE THE BATTERY.

DISCONNECT ALL ELECTRICAL POWER, AIR AND OXYGEN SOURCES BEFORE ATTEMPTING ANY DISSEMBLY. FAILURE TO DO SO COULD RESULT IN INJURY TO THE SERVICE TECHNICIAN AND/OR EQUIPMENT.

THIS MEDICAL DEVICE SHOULD NEVER BE SERVICED OR THE COVERS REMOVED WHEN CONNECTED TO A PATIENT. INTERNAL MAINTENANCE MAY AFFECT THE OPERATION OF THE UNIT, JEOPARDIZING PATIENT CARE.

USE EXTREME CARE WHEN SOLDERING TO PREVENT SOLDER SPLASHES, DAMAGE TO CONNECTORS, SOLDER BRIDGES (SOLDER CONNECTIONS BETWEEN TWO TERMINAL POINTS OR TO GROUND) OR POSSIBLE SHORT CIRCUITS DUE TO BURNED WIRE INSULATION. ANY OF THESE CONDITIONS MAY CAUSE VENTILATOR FAILURE, RESULTING IN POSSIBLE INJURY TO THE PATIENT.

DO NOT USE TEFLON TAPE IN PLACE OF PIP SEALANT. SHARP THREADS MAY SHRED THE TAPE AND THE FIBRES COULD POSSIBLY OCCLUDE CRITICAL ORIFICES, RESULTING IN POSSIBLE PATIENT INJURY.

THE VERIFICATION AND/OR CALIBRATION PROCEDURES CONTAINED IN SECTION 5 MUST BE COMPLETED WHEN ANY PART/ASSEMBLY HAS BEEN REMOVED AND/OR REPLACED. FAILURE TO DO SO COULD RESULT IN MALFUNCTION OF THIS MEDICAL DEVICE AND/OR INJURY TO THE PATIENT.

HAZARDOUS VOLTAGES EXIST WITHIN THIS MEDICAL DEVICE. ALWAYS OBSERVE APPROPRIATE SAFETY PRECAUTIONS WHEN WORKING ON THE UNIT WHILE THE MACHINE IS CONNECTED TO AN ELECTRICAL POWER SOURCE TO PREVENT POSSIBLE ACCIDENTAL ELECTRICAL SHOCK.

CAUTIONS

The following CAUTIONS must be read and understood before performing any of the procedures in this Service Manual.

IF ANY OF THE FOLLOWING PROCEDURES CANNOT BE VERIFIED AS OUTLINED IN THIS DOCUMENT, DISCONNECT THE VENTILATOR AND REFER IT TO HAMILTON MEDICAL AG OR A HAMILTON MEDICAL AUTHORIZED SERVICE FACILITY.

DO NOT USE MEK OR TRICHLOROETHYLENE, AS DAMAGE TO SURFACES MAY RESULT. DO NOT ALLOW ANY LIQUID TO SPILL OR DRIP INTO THE VENTILATOR.

DO NOT GAS STERILIZE THE VENTILATOR, THE INTERNAL MATERIALS ARE NOT COMPATIBLE WITH GAS STERILIZATION TECHNIQUES.

DO NOT OVERHEAT WIRING OR COMPONENTS BY APPLYING HEAT TO HEAT SHRINK TUBING. EQUIPMENT DAMAGE COULD RESULT.

DO NOT USE TAPE TO INSULATE THE JOINTS, TAPE CAN DETERIORATE AND BECOME LOOSE.

BEFORE USING ANY TEST EQUIPMENT (ELECTRONIC OR PNEUMATIC) FOR CALIBRATION PROCEDURES (OTHER THAN OPERATIONAL VERIFICATION), THE ACCURACY OF THE INSTRUMENTS MUST BE CERTIFIED BY A TESTING LABORATORY. THE LABORATORY MASTER TEST INSTRUMENTS MUST BE TRACEABLE TO THE U.S. BUREAU OF STANDARDS OR EQUIVALENT. WHEN VARIANCES EXIST BETWEEN THE INDICATED AND ACTUAL VALVES, THE CALIBRATION CURVES (PROVIDED FOR EACH INSTRUMENT BY THE TESTING LABORATORY) MUST BE USED TO ESTABLISH THE ACTUAL CORRECT VALUES. THIS CERTIFICATION PROCEDURE SHOULD BE PERFORMED AT LEAST ONCE EVERY SIX MONTHS. MORE FREQUENT CERTIFICATION MAY BE REQUIRED BASED ON USAGE AND ENVIRONMENT.

THE CIRCUIT BOARDS ARE SUBJECT TO DAMAGE BY STATIC ELECTRICITY. DO NOT TOUCH COMPONENTS, CIRCUIT OR CONNECTOR FINGERS WITH HANDS. HANDLE ONLY ON THE EDGES.

LIST OF ABBREVIATIONS

AFP33X.0 (AFP33F.0) (AFP33B.0)	Frontpanel Processor 33X.0 33: Software Version X: Flow Trigger and PCV (F: Flow Trigger, B: Standard) .0: development version
Auto-PEEP	airway occlusion pressure (select monitor selector PEEP)
Auto Zero	The Auto Zero assembly provides an automatical zero point adjustment of the pressure sensor.
ESD	Electro Static Discharge
ETS	Expiratory Trigger Sensitivity in the SPONT mode. Switch from I to E, if the inspiratory flow is reduced to a selected amount of inspiratory peak flow.
Flow Trigger	Flow Trigger adjusts from 3 to 15 l/min with automatic Expiratory Base Flow from 4 to 30 l/min . Adjustable in all modes.
MMV	Minimum Minute Ventilation
Nebulizer	To turn on the nebulizer gas flow, press touch key "Neb" (15 min).
NCP33A.6	Control Processor 33A.6 33: Software version A: AMADEUS 6: development version
PCV	Pressure Control Ventilation
FT&PCV	Pressure Control Ventilation and Flow Trigger
PEEP	Positive End Expiratory Pressure
p0.1	Pressure drop, 100 msec after beginning the inspiration while the Hold-Key is pressed.
RMI33A.0	Respiratory Mixer 33A.0 33: Software version A: AMADEUS 0: development version

LANGUAGES ON THE TOP ENCLOSURE
(version 33)

AMADEUS USA English		AMADEUS British English		AMADEUS German	
Control panel		Control panel		Control panel	
Modes:		Modes:		Modes:	
PCV-CMV		PCV-CMV		PCV-CMV	
PCV-SIMV		PCV-SIMV		PCV-SIMV	
Manual Breath		Manual Breath		Man Atemzug	
ASSIST CONTROL		(S)CMV		(S)CMV	
SIMV		SIMV		SIMV	
SPONT		SPONT		SPONT	
Hold		Hold		Hold	
Sigh		Sigh		Seufzer	
Neb (15 min)		Neb (15 min)		Vernebler (15 min)	
Cal O ₂		Cal O ₂		Kal O ₂	
Cal Flow		Cal Flow		Kal Flow	
Test Tightness		Test Tightness		Dichtigkeitstest	
Opt Pressure		Opt Pressure		Opt Druck	
Pediatric System		Paediatric System		Pädiatrie System	
O ₂ Flush		O ₂ Flush		O ₂ Flush	
Controls:		Controls:		Controls:	
Rate	: bpm	Rate	: bpm	Frequenz	: AZ/min
Tidal Volume	: ml	Tidal Volume	: ml	Zugvolumen	: ml
Insp, Pause	: % Cycle time	Insp, Pause, Expiratory	: % Cycle time, I:E	Insuff, Plateau, Expiration	: % Atemzyklus, I:E
Pressure Control	: cm H ₂ O	Pressure Control	: cm H ₂ O	Beatmungsdruck	: mbar
Pressure Trigger	: cm H ₂ O (below PEEP)	Pressure Trigger	: cm H ₂ O (below PEEP)	Druck Trigger	: mbar (unter PEEP)
PEEP/CPAP, Pressure Support	: cm H ₂ O	PEEP/CPAP, P _{sup} (Support)	: cm H ₂ O	PEEP/CPAP, P _{sup} (Hilfe)	: mbar
Oxygen	: %	Oxygen	: %	Sauerstoff	: Vol %
Flow Trigger	: lpm	Flow Trigger	: lpm	Flow Trigger	: l/m

AMADEUS USA English		AMADEUS British English		AMADEUS German	
Alarm panel		Alarm panel		Alarm panel	
Scales:		Scales:		Scales:	
High Rate	: bpm	High Rate	: bpm	obere Frequenzgrenze	: AZ/min
High Pressure	: cm H ₂ O	High Pressure	: cm H ₂ O	obere Druckgrenze	: mbar
Expired Minute Volume (Low/High)	: lpm	Expired Minute Volume (Low/High)	: lpm	Exsp Min Vol (untere/obere)	: l/m
Oxygen Limits	: %	Oxygen Limits	: %	Sauerstoff	: Vol %
LEDS:		LEDS:		LEDS:	
High Pressure		High Pressure		Druck zu hoch	
Disconnection		Disconnection		Disconnektion	
Apnea		Apnea		Apnoe	
Expired Minute Volume		Expired Minute Volume		Exsp Min Volumen	
Oxygen Concentration		Oxygen Concentration		Sauerstoff Vol %	
High Rate		High Rate		Frequenz zu hoch	
Operator		Operator		Bediener	
Flow Sensor		Flow Sensor		Flow Sensor	
Power		Power		Netz	
Gas Supply		Gas Supply		Gas-Versorgung	
Inoperative		Inoperative		Störung	
Patient Monitor		Patient Monitor		Patient Monitor	
Pressure	cm H ₂ O	Pressure	cm H ₂ O	Beatmungsdruck	mbar
Trigger		Trigger		Trigger	
Rate	: bpm	Rate	: bpm	Frequenz	: AZ/min
Oxygen	: %	Oxygen	: %	Sauerstoff	: Vol %
Exp Min Vol	: lpm	Exp Min Vol	: lpm	Exsp Min Vol	: l/min
Exp Tidal Vol	: ml	Exp Tidal Vol	: ml	Zugvolumen	: ml

AMADEUS USA English		AMADEUS British English		AMADEUS German	
Res	: cm H ₂ O/l/s	Res	: cm H ₂ O/l/s	R	: mbar/l/s
Compl	: ml/cm H ₂ O	Compl	: ml/cm H ₂ O	C	: ml/mbar
PEEP	: cm H ₂ O	PEEP	: cm H ₂ O	PEEP	: mbar
Insp Peak Flow	: lpm	Insp Peak Flow	: lpm	Insp max Flow	: l/min
I:E	: 1:...	I:E	: 1:...	I:E	: 1:...
Peak Pressure	: cm H ₂ O	Peak Pressure	: cm H ₂ O	P _{max}	: mbar
Mean Pressure	: cm H ₂ O	Mean Pressure	: cm H ₂ O	P _{mean}	: mbar
Insp Time	: s	Insp Time	: s	t _{exp}	: s
Leak Volume	: ml	Leak Volume	: ml	Volumenverlust	: ml
Option Switches:		Option Switches:		Option Switches:	
1. Backup		1. Backup		1. Backup	
2. Paediatric		2. Paediatric		2. Paediatric	
3. Sigh On		3. Sigh On		3. Sigh On	
4. Date Entry		4. Date Entry		4. Date Entry	
5. -		5. -		5. -	
6. ETS		6. ETS		6. ETS	
7. Apnea		7. Apnea		7. Apnea	
8. -		8. -		8. -	
9. Flow Pattern		9. Flow Pattern		9. Flow Pattern	

SECTION OVERVIEW

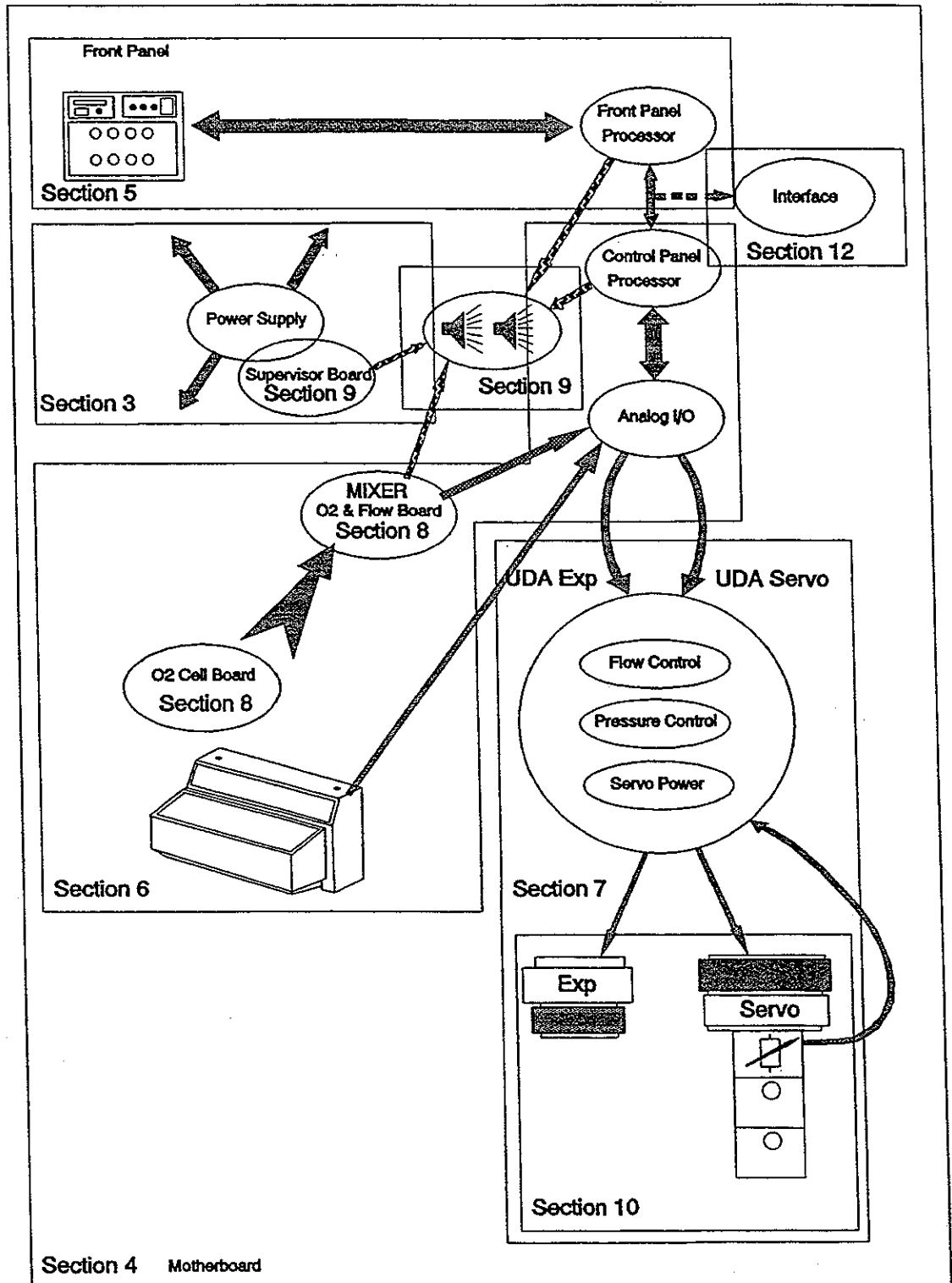


fig. 0_1

1	AMADEUS CONCEPT & BASIC PRINCIPLES	1-2
1.1	THE CONCEPT	1-2
1.2	BASIC PRINCIPLES	1-2
	BLOCK SCHEMATIC AMADEUS	1-3
614067	Block Schematic	1-3
614062	Block Schematic	1-4
	MAIN DRAWING	1-5
153110	Main Drawing	1-5
2	PART LIST	1-6
2.1	BOARDS	1-6
2.2	EPROMS	1-7
2.3	VALVES AND ASSEMBLING GROUPS	1-8
2.4	SENSORS FOR MEASUREMENT	1-9
2.5	CABLES	1-9
2.6	PANELS	1-10
2.7	ENCLOSURES	1-10
2.8	KNOBS, SWITCHES AND POTENTIOMETERS	1-11
2.9	O-RING, TUBING AND FUSES	1-14
2.10	STICKERS AND INSERTS	1-15
2.11	MISCELLANEOUS	1-18
2.12	TEST EQUIPMENT	1-19
2.12.1	PRESSURE CONTROLLER	1-20

1 AMADEUS CONCEPT & BASIC PRINCIPLES

1.1 THE CONCEPT

The concept behind the **AMADEUS** Ventilator is to provide state of the art ventilation in a human engineered design. Current and future trends in critical care ventilatory management point to precise flow, pressure and oxygen control. Application to both adult and pediatric patients using a variety of modes is necessary. Patient monitoring and rapid, understandable alarms are extremely important. All this and more will be found in the **AMADEUS**.

To fulfill the above performance completely new gas handling devices have been developed for mixing, controlling and monitoring flows. These devices are interfaced with advanced computer technology to offer broad operational capability. This is the **AMADEUS** concept. It will provide a new dimension in the management of critically ill patients now and for the future.

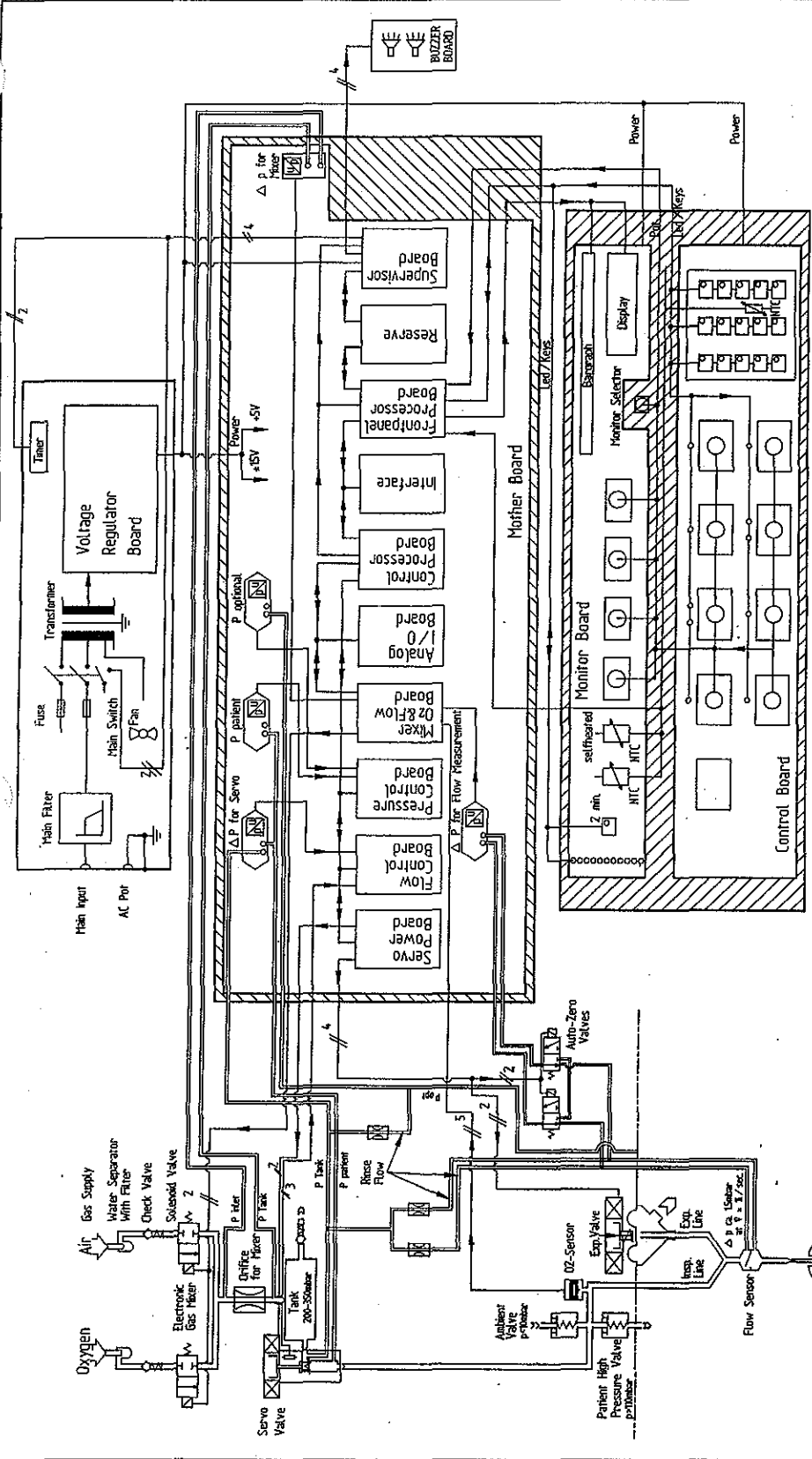
1.2 BASIC PRINCIPLES

The **AMADEUS** Ventilator consists of two separate but interconnected systems: the pneumatic flow system and an electronic control system.

The pneumatic flow system routes the flow of gas through the ventilator. Oxygen and medical grade air enter the ventilator at 3.5 bar (50 psi) pressure (the acceptable range is 2 to 6 bar or 28 to 86 psi). These gases enter the air/oxygen mixer where they are combined at the operator adjusted percentage and reduced in pressure to 350 cm H₂O. The gases then enter a large aluminum reservoir tank which holds almost eight liters of mixed gases when compressed to 350 cm H₂O. An electronically controlled Servo Flow Valve proportions the gas flow from the reservoir tank to the patient breathing circuit. As the gases exit the ventilator they pass by an oxygen analyzer, a safety ambient air inlet valve and a back-up mechanical overpressure valve. In the patient breathing circuit is a bi-directional flowsensor, placed between the "Y" piece and the patient, to measure gas flows. The exhaled gases exit through an electronically controlled, large surface area exhalation valve located at the ventilator.

The electronic control system consists of three interrelated subsystems. Each subsystem has its own microcomputer and software to perform its tasks as well as checking the function of the other subsystems. The Frontpanel microprocessor subsystem is responsible for interpreting the signals (control settings) from the frontpanel and generating all of the displays and alarms on the frontpanel. The Control microprocessor subsystem accepts the signals from the Frontpanel microprocessor controls the gas flows to and from the patient. The air/oxygen mixer microprocessor subsystem controls the mixing of air and oxygen. There is extensive self checking for proper operation of these two systems.

Used with marked Safety Version
30 31



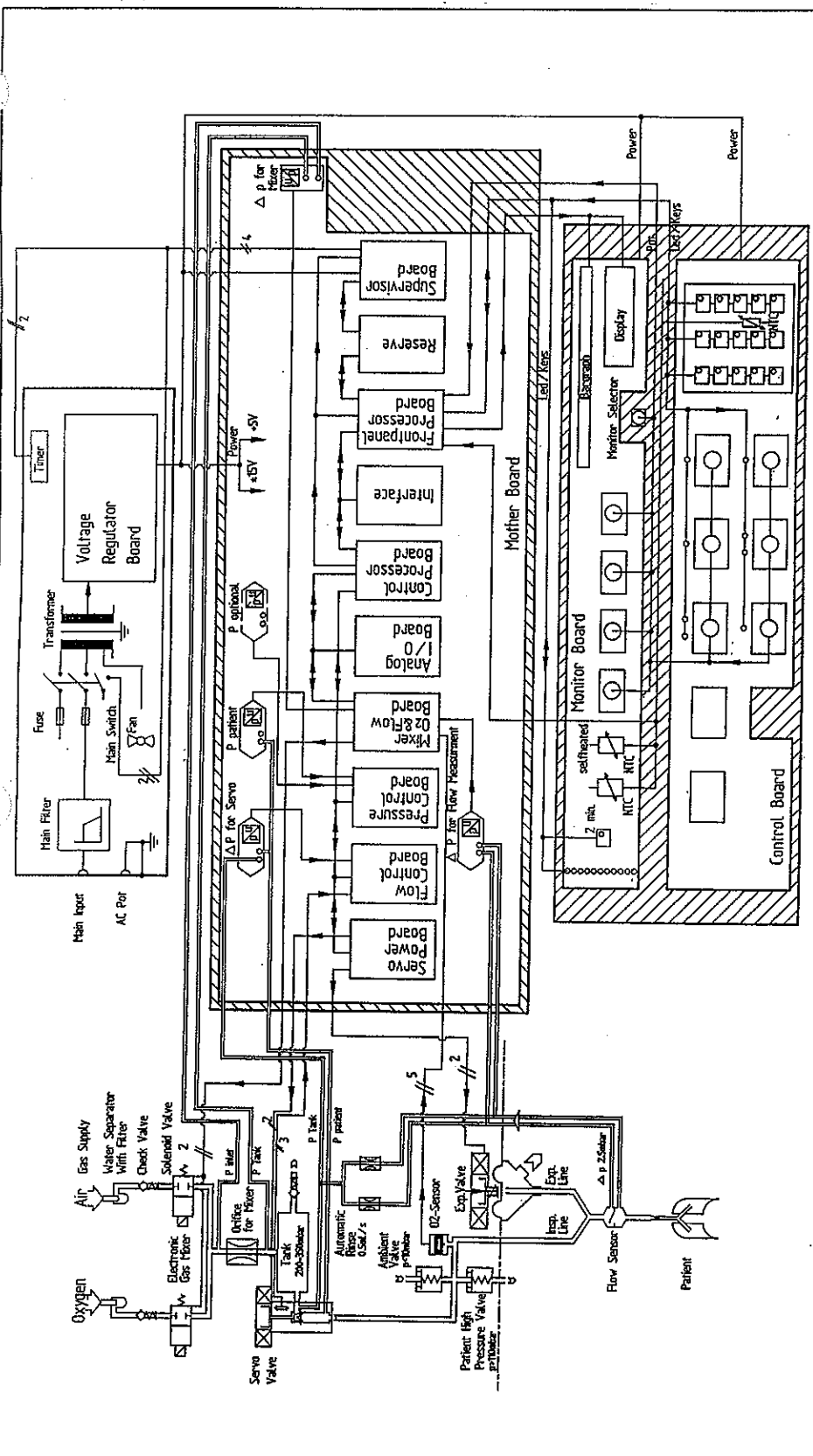
Material		Oberflaeche	
Blockschematic AMADEUS FT HAMILTON MEDICAL <small>22.2.1994 7:24 am</small>		Untertolerierte	614067
		MASSE	
		Massstab	1992-08-27 IR-BA
		Gez	1994-09-24
Gepr			
Dept	1994-02-16 LEHR3		

Diese Zeichnung gilt als dem jeweiligen Inhaber persönlich anvertraut. Das Eigentum und das Urheberrecht verbleibt ohne unsere schriftliche Genehmigung weiterhin bei uns. Weder kopiert noch Dritten zugeführt werden.

Rev.	
Änd-Nr.	

SECTION 1 CONCEPT AND PARTICIPLES

Used with original Service Manual

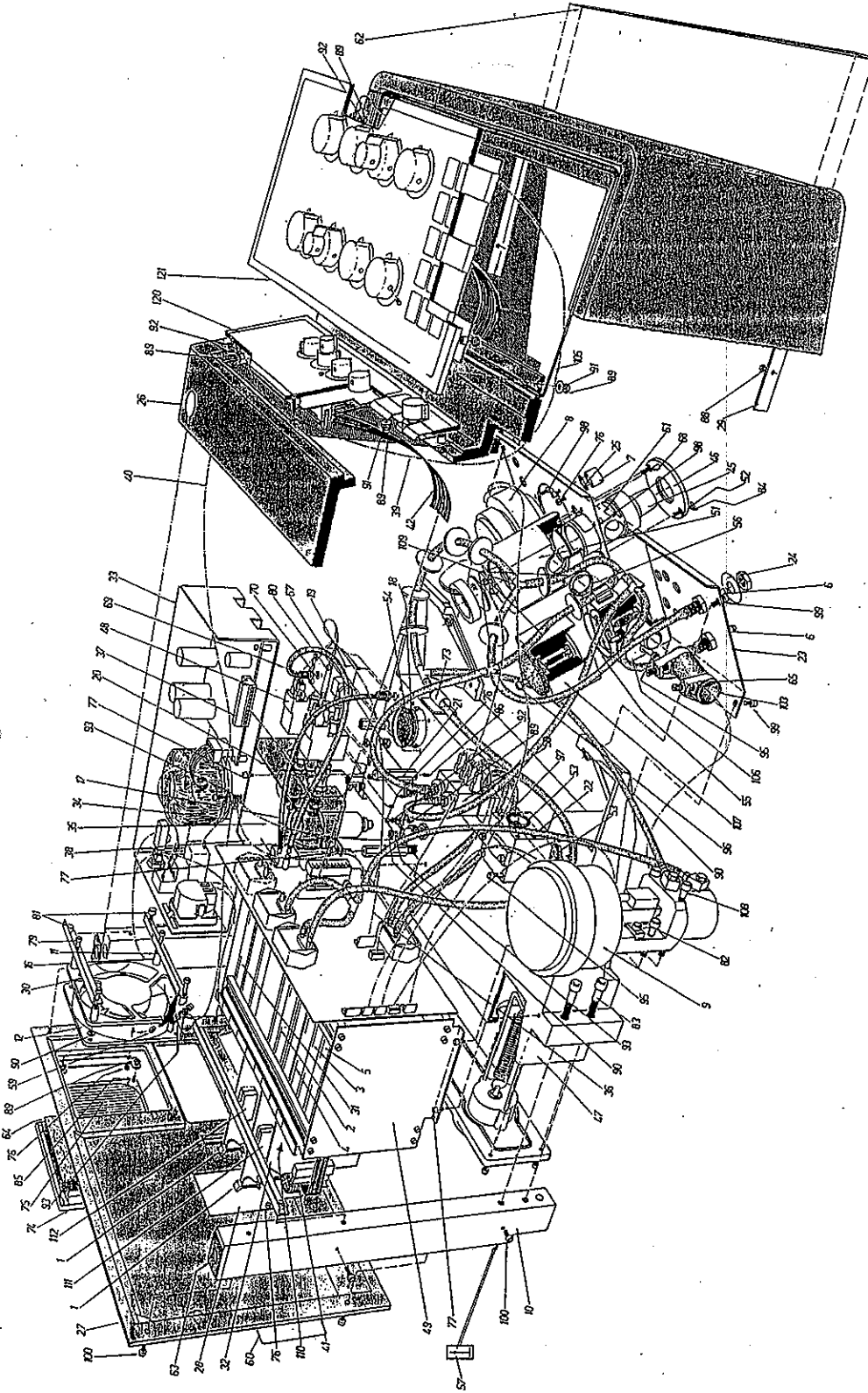


Material		Überfläche	
Gebört zu Schnellserie		Masse	
<p>Blockschematic AMADEUS</p> <p>HAMILTON MEDICAL</p> <p>24.8.1984 7.3.1985</p>		Massstab	88 10 24
		Rec	Schub
		Gepr	90 02 06
		Gez	D.C.
		Gepl.	
		614062	

Diese Zeichnung gilt als dem jeweiligen Inhaber persönlicher anvertraut. Das Eigentum und das Urheberrecht verbleibt bei uns. Ohne unsere schriftliche Genehmigung dürfen die Zeichnungen weder kopiert noch Dritten zugänglich gemacht werden.

Rev				
Änd-Nr				
Datum				
Visum				
D				
N				
E				
A				

Listed with manual 5		Version
30	31	3



1	2	3	4	5	6	7	8	9	10	11	12	13	14	15	16	17	18	19	20	21	22	23	24	25	26	27	28	29	30	31	32	33	34	35	36	37	38	39	40	41	42	43	44	45	46	47	48	49	50	51	52	53	54	55	56	57	58	59	60	61	62	63	64	65	66	67	68	69	70	71	72	73	74	75	76	77	78	79	80	81	82	83	84	85	86	87	88	89	90	91	92	93	94	95	96	97	98	99	100	101	102	103	104	105	106	107	108	109	110	111	112	113	114	115	116	117	118	119	120	121
---	---	---	---	---	---	---	---	---	----	----	----	----	----	----	----	----	----	----	----	----	----	----	----	----	----	----	----	----	----	----	----	----	----	----	----	----	----	----	----	----	----	----	----	----	----	----	----	----	----	----	----	----	----	----	----	----	----	----	----	----	----	----	----	----	----	----	----	----	----	----	----	----	----	----	----	----	----	----	----	----	----	----	----	----	----	----	----	----	----	----	----	----	----	----	----	----	----	----	-----	-----	-----	-----	-----	-----	-----	-----	-----	-----	-----	-----	-----	-----	-----	-----	-----	-----	-----	-----	-----	-----

✓M	Item: AMADEUS FT	Stamp
	HAMILTON MEDICAL	Stamp

22.2.1984 7.23am
HAMILTON MEDICAL AG Service Manual AMADEUS Order-No. 610 221 1-5

SECTION 1 CONCEPT AND PARTICIPLES	Used with marked Software Version			
	30	31	32	33

2 PART LIST

Accessories which are used for both the VEOLAR and AMADEUS are marked with an asterisk (*).

Part Number	Part Description (through out Manual)	Position Drawing	Quantity per Unit
-------------	---------------------------------------	------------------	-------------------

2.1 BOARDS

150 320*	Processor Board without E-PROM, identical for: - Front Panel Processor Board - Control Processor Board	1	2
150 400*	Analog I/O Board	2	1
150 415*	Flow Control Board (works only with the Servo Valve No. 151 871)	3	1
150 410*	Flow Control Board (works only with Servo Valve No. 151 660 and is not available any more since 1994, changed to No. 151 415)		1
150 425*	Pressure Control Board (for SW version 33)	4	1
150 420*	Pressure Control Board (for SW version 30,31,32)		1
150 430*	Servo Power Board	5	1
153 310	Mother Board		1
153 320	Supervisor Board (this Board includes <u>no</u> Buzzer; the Order Number for the Buzzer Kit is 153 982)	31	1
153 380	Mixer/O ₂ and Flow Board without E-PROM (for SW version 33)	32	1
153 330	Mixer/O ₂ and Flow Board without E-PROM (for SW version 30,31,32)		1
153 345	Monitor Board (without Potentiometer)		1
153 355	Control Board (without Potentiometer)		1

SECTION 1 PART LIST	Used with marked Software Version			
	30	31	32	33

Part Number	Part Description (through out Manual)	Position Drawing	Quantity per Unit
-------------	---------------------------------------	------------------	-------------------

2.2 EPROMS

150 521* Interface E-PROM (NIK 01S.1) 1

EPROMS FOR VERSION 33

153 371 E-PROM for Control Panel Processor Board (NCP33A.6)

153 367 E-PROM for Mixer, O₂ and Flow Board (RMI33A.0)

EPROMS FOR VERSION 30,31 AND 32

153 986 Software Kit Version 32
NOTE: This Software Version works only with the Auto Zero Assembly Kit 153 987

153 365 E-PROM for Front Panel Processor Board (AFP 32S.2)

153 366 E-PROM for Control Processor Board (NCP 32A.2)

153 984 E-PROM set **AMADEUS** (version 31) english (including all three EPROMs)

153 983 E-PROM set **AMADEUS** (version 31) german

153 336 E-PROM for Front Panel Processor Board (AFP 31S.1)

153 337* E-PROM for Control Processor Board (NCP 31A.2)

153 333 E-PROM for Mixer O₂ and Flow Board (RMI 0301, for vers.30,31 and 32)

SECTION 1	PART LIST	Used with marked Software Version			
		30	31	32	33

Part Number	Part Description (through out Manual)	Position Drawing	Quantity per Unit
-------------	---------------------------------------	------------------	-------------------

2.3 VALVES AND ASSEMBLING GROUPS

153 400	Power Supply Complete	33	1
153 203	Fan Complete	12	1
151 465*	Expiration Valve Actuator Complete (for SW version 33)	8	1
151 470*	Expiration Valve Actuator Complete (for SW version 30,31,32)		1
151 871*	Servo Valve unpacked not available, order 151 882	9	1
151 882*	Service Servo Valve (Servo Valve works only with the Flow Control Board No. 150 415)		
151 881*	Servo Valve Kit (includes Servo Valve and Flow Control Board Order No. 150 415)		
394 017	Magnetic Valve for Mixer		2
153 910	O ₂ -Block	51	1
153 915	O ₂ -Cell Holder		1
153 900	Pat. Overpressure Valve		1
153 905	Ambient Valve		1
153 645	Tank Cover (incl. Tank Overpressure Valve)		1
153 650	Air Inlet Compl.		1
153 660	O ₂ Inlet Compl.		1
279 586	Check Valves		2
153 987	Auto Zero Assembly Kit NOTE: This Kit works only with the SW version 32 and 33.		1

SECTION 1	PART LIST	Used with marked Software Version			
		30	31	32	33

Part Number	Part Description (through out Manual)	Position Drawing	Quantity per Unit
-------------	---------------------------------------	------------------	-------------------

2.4 SENSORS FOR MEASUREMENT

399 010*	Pressure Sensor P Patient		1
399 029	Pressure Sensor delta P Flow Sensor		1
399 030	Pressure Sensor delta P Mixer		1
399 032	Pressure Sensor delta P (pTank-Ppat)		1

2.5 CABLES

153 450	Earth Cable Fan	34	1
153 451	Earth Cable Mixer Plate	35	1
153 454	Earth Cable Mother Board	38	1
153 455	Earth Cable Control Board	39	1
153 456	Earth Cable Monitor Board	40	1
153 452	Mixer Valve Cable	36	1
153 453	Power Supply Cable	37	1
153 457	Analog I/O Signal Cable	41	1
153 458	Front Panel Cable	42	1
153 459	Supervisor Cable		1

SECTION 1	PART LIST	Used with marked Software Version			
		30	31	32	33

Part Number	Part Description (through out Manual)	Position Drawing	Quantity per Unit
-------------	---------------------------------------	------------------	-------------------

2.6 PANELS

FOR LIGHT BLUE INSTRUMENTS

Monitor Panel without Components

153 811	German Version (SW version 33)		1
153 815	English Version (SW version 33)		1

Control Panel without Components

153 827	German FT&PCV-Version (SW version 33X)		1
153 825	English FT&PCV-Version (SW version 33X)		1
153 823	English FT-Version (SW version 33F)		1
153 821	English Version (SW version 33B)		1

FOR BLUE INSTRUMENTS

Monitor Panel without Components

153 682	German Version (SW version 30,31,32)		1
153 691	English Version (SW version 30,31,32)		1
153 701	French Version (SW version 30,31,32)		1

Control Panel without Components

153 711	German Version (SW version 30,31,32)		1
153 721	English Version (SW version 30,31,32)		1
153 731	French Version (SW version 30,31,32)		1

2.7 ENCLOSURES

153 253	Enclosure (order Technical Sticker separately)	26	1
153 255	Rear Panel (for Version 30, 31 and 32)		1
153 263	Rear Panel (for Version 33, optional switches description printed)		1

SECTION 1	PART LIST	Used with marked Software Version			
		30	31	32	33

Part Number	Part Description (through out Manual)	Position Drawing	Quantity per Unit
-------------	---------------------------------------	------------------	-------------------

2.8 KNOBS, SWITCHES AND POTENTIOMETERS

Switches and Potentiometers

153 435	Potentiometer Single Section		7
153 440	Potentiometer Dual Section		3
153 445	Monitor Selector Switch		1
405 042	Knob Screw M 3x4 (100 pieces)		28

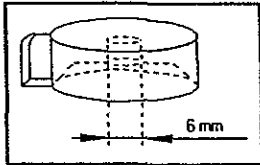


figure 1_1

Potentiometer Knob 1

(for Rate, V_T , Pressure Trigger, Oxygen, Flow Trigger or Pressure Control)

5(6)

- 150 631* - for blue instrument
- 150 684 - for light blue instrument

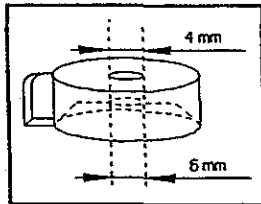


figure 1_2

Potentiometer Knob 3

(for Insuffl., PEEP/CPAP)

2

- 150 633* - for blue instrument
- 150 686 - for light blue instrument

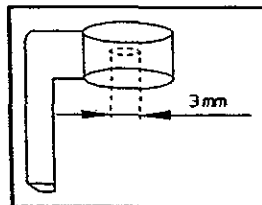


figure 1_3

Potentiometer Knob 5

(for Plateau/Exp, Pressure Support)

2

- 150 635* - for blue instrument
- 150 687 - for light blue instrument

SECTION 1	PART LIST	Used with marked Software Version			
		30	31	32	33

Part Number	Part Description (through out Manual)	Position Drawing	Quantity per Unit
-------------	---------------------------------------	------------------	-------------------

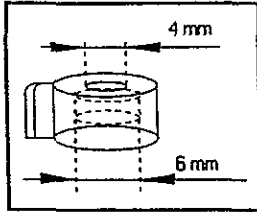


figure 1_4

Potentiometer Knob 7

1

(for $V_{exp/min}$ Min Alarm)

- 150 637* - for blue instrument
- 150 688 - for light blue instrument

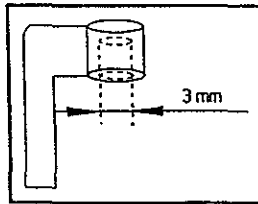


figure 1_5

Potentiometer Knob 8

1

(for $V_{exp/min}$ Max Alarm)

- 150 638* - for blue instrument
- 150 689 - for light blue instrument

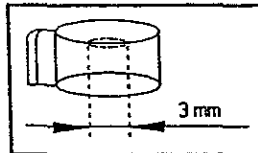


figure 1_6

Potentiometer Knob 9

2

(for High Pressure Alarm and High Frequency Alarm)

- 150 638* - for blue instrument
- 153 696 - for light blue instrument

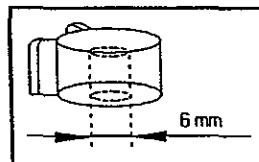


figure 1_7

Potentiometer Knob 10

1

(for Oxygen Limits)

- 150 638* - for blue instrument
- 153 697 - for light blue instrument

SECTION 1 PART LIST	Used with marked Software Version				
	30	31	32	33	

Part Number	Part Description (through out Manual)	Position Drawing	Quantity per Unit
-------------	---------------------------------------	------------------	-------------------

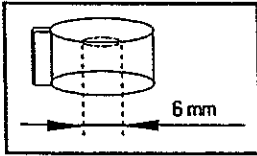


figure 1_8

Potentiometer Knob 11
(for Monitor Selector)

1

- 150 638* - for blue instrument
- 153 698 - for light blue instrument

SECTION 1	PART LIST	Used with marked Software Version			
		30	31	32	33

Part Number	Part Description (through out Manual)	Position Drawing	Quantity per Unit
-------------	---------------------------------------	------------------	-------------------

2.9 O-RING, TUBING AND FUSES

363 012	Fuse F1 3A15T		1
363 015	Fuse F3 1A.25T		1
363 016	Fuse F2 2A5T		1
363 032*	Main Fuse 800 mA TT (Fuse for 220V/240V)		2
363 041*	Main Fuse 1.6A TT (Fuse for 100V/120V)		2
254 029*	O-Ring ORM 0195-30 (for Servo Valve)	29	1
254 052	O-Ring for O ₂ and Air Adaptor		2

SECTION 1	PART LIST	Used with marked Software Version				
		30	31	32	33	

Part Number	Part Description (through out Manual)	Position Drawing	Quantity per Unit
-------------	---------------------------------------	------------------	-------------------

2.10 STICKERS AND INSERTS

Nebulizer Kit insert set:

255 555	American/English/German/French		1
---------	--------------------------------	--	---

Optional Pressure Sensor insert set:

255 565	American/English/German/French		1
---------	--------------------------------	--	---

255 448	2 Min. Alarm Sticker (to cover the 2 Min. Alarm button)		1
---------	--	--	---

255 241	O ₂ -Cell Holder Sticker	61	1
---------	-------------------------------------	----	---

Sticker on Top Enclosure:

255 242	Sticker Tech. Panel German	62	1
---------	----------------------------	----	---

255 243	Sticker Tech. Panel English/American	62	1
---------	--------------------------------------	----	---

255 244	Sticker Techn. Panel French	62	1
---------	-----------------------------	----	---

SECTION 1	PART LIST	Used with marked Software Version			
		30	31	32	33

Part Number	Part Description (through out Manual)	Position Drawing	Quantity per Unit
-------------	---------------------------------------	------------------	-------------------

FOR LIGHT BLUE INSTRUMENTS

Insert with Optional Parameters for Monitor Selector:

255 538 German Set: 1

left:

version 1 Resist, Compl
 version 2 t insp, p mittel
 version 3 l:E, Compl

right:

version 1 PEEP, Insp max Fluss
 version 2 PEEP, Volumenverlust
 version 3 PEEP, p max

255 551 English/American Set: 1

left:

version 1 Res, Compl
 version 2 Insp Time, Mean Press
 version 3 l:E, Compl

right:

version 1 PEEP, Insp Peak
 version 2 PEEP, Leak Volume
 version 3 PEEP, Peak Press

Lettering for Optional Control Keys (top)

255 606 Neutral (long, blue) 1

Lettering for Optional Control Keys (middel, bottom)

255 607 Neutral (long, light blue) 2

SECTION 1	PART LIST	Used with marked Software Version			
		30	31	32	33

Part Number	Part Description (through out Manual)	Position Drawing	Quantity per Unit
-------------	---------------------------------------	------------------	-------------------

FOR BLUE INSTRUMENTS

Insert with Optional Parameters for Monitor Selector left:

153 686	Resist, Compl (German)		1
153 692	Resist, Compl (English)		1
153 702	Resist, Compl (French)		1

Insert with Optional Parameters for Monitor Selector right:

153 687	PEEP, Insp max Fluss (German)		1
153 693	PEEP, Insp Peak Flow (English)		1
153 703	PEP, Débit Crête in (French)		1

Lettering for Optional Control Keys (top)

153 712	Neutral (light blue)		1
---------	----------------------	--	---

Lettering for Optional Control Keys (middle)

153 713	Neutral (blue)		1
---------	----------------	--	---

Lettering for Optional Control Keys (bottom)

153 714	Neutral (blue)		1
153 715	Print Trend, Print (German)		1
153 723	Print History, Print (English)		1
153 733	Imprim. Tendance, Imprim (French)		1

SECTION 1	PART LIST	Used with marked Software Version			
		30	31	32	33

Part Number	Part Description (through out Manual)	Position Drawing	Quantity per Unit
-------------	---------------------------------------	------------------	-------------------

2.11 MISCELLANEOUS

279 166*	Dust Filter	64	1
391 029*	Fan Cover	74	1
369 030*	Rechargeable Battery NiCa, 3,6 Volt		1
153 982*	Buzzer Kit		1
153 217	Sinterplate (Mixer Orifice)	18	1
153 218	Sinterplate Holder (Mixer Orifice)	19	1
153 638	Sound Absorber (Tankoverpressure Valve)		1
279 583	Gas Inlet Filter Compl. (incl. Filter and Watertrap)		2
279 444	Microfilter for Gas Inlet		2
279 445	Watertrap for Gas Inlet		2
153 270	Automatic Rinse Assembly (ver.33)		1
151 670*	Automatic Rinse Assembly		1
151 232*	Pressure Connector (Flow Sensor, Optional Pressure, Nebulizer)	6	2
153 226*	Flow Sensor Proximal Code Disk		1
153 590*	Nebulizer Code Disk		1
153 591*	P- _{optional} Code Disk		1
279 622	O ₂ Main adaptor (for Engl. Instr.)		1
279 592	Air Main adaptor (for Engl. Instr.)		1
279 621	O ₂ Main adaptor (for German and French Instrument)		1
279 624	Air Main adaptor (for German and French Instrument)		1

SECTION 1	PART LIST	Used with marked Software Version			
		30	31	32	33

Part Number	Part Description (through out Manual)	Position Drawing	Quantity per Unit
-------------	---------------------------------------	------------------	-------------------

2.12 TEST EQUIPMENT

500 280*	Capillary Tube 20 ml/s Control of tightness and calibration of Servo Valve at 20 ml/s		
500 290*	Orifice 500 ml/s Calibration of Servo Valve at 500 ml/s		
500 300*	Pressure Connector Measures pressure at inspiratory outlet, control of Pressure Sensor, PEEP etc.		
500 340*	Oxygen-Cell Simulator Tests the Oxygen Measuring Device for calibration and linearity		
500 630	Adaptor for Oxygen Cell Simulator (AMADEUS)		
500 350*	Analog I/O Board Test Box Calibration and test of various functions on Analog I/O Board (A/D, D/A Converter)		
500 330*	Manual Pressure Pump Tests Pressure Sensors and tightness		
500 375	Adaptor for Tank Overpressure Valve (AMADEUS)		
500 335*	Micro Flow and Pressure Regulator		
202 150*	Calibration Syringe 500 ml		
279 199*	T-piece (2 pieces)		
151 235*	Pressure Tube 1, 150 cm (2 pieces)		
500 370	Adaptor for Tankoverpressure Valve (VEOLAR)		
500 647	Adaptor for O₂ Cell Simulator (VEOLAR)		
500 049	Presssure Controller (WIKA) 100 - 240 V Find further information on the next page.		

SECTION 1	PART LIST	Used with marked Software Version			
		30	31	32	33

2.12.1 PRESSURE CONTROLLER

500 049* **Pressure Controller WIKA** (0 - 400 mbar, 0 - 10bar,
100V - 240V, 50/60Hz,)

Note: Better pricing of the P.C. might be available at your local WIKA distributor. See the following page for a list of world wide Sales & Service departments.

The Pressure Controller WIKA includes the following parts:

1. Pressure Controller (Main unit)

Digits: ± 10000
Display accuracy: $\pm 0,06 \% \pm 1$ digit

(WIKA order no.909.40.500)

2. Pressure probe 0 - 400 mbar, Accuracy < 0,5 %

(WIKA order no.891.13.590)

3. Pressure probe 0 - 10 bar, Accuracy < 0,5 %

(WIKA order no.891.13.590)

4. Accumulator charger

DC 6V 50/60Hz, AC 100...240V
Main power connector, version switzerland)

(WIKA order no. 909.40.505)

2	ALARM SYSTEM	2-2
2.1	GLOSSARY	2-2
2.2	HIGH PRESSURE	2-3
2.3	DISCONNECTION	2-3
	2.3.1 DISCONNECTION - VENTILATOR SIDE	2-3
	2.3.2 DISCONNECTION - PATIENT SIDE	2-4
	2.3.3 LOSS OF PEEP	2-4
2.4	APNEA	2-5
	2.4.1 FLOW APNEA	2-5
	2.4.2 FAIL TO CYCLE	2-5
2.5	EXPIRED MINUTE VOLUME	2-5
	2.5.1 EXPIRED MINUTE VOLUME - LOW/HIGH	2-5
2.6	OXYGEN CONCENTRATION	2-6
	2.6.1 OXYGEN CONCENTRATION - LOW/HIGH	2-6
2.7	HIGH RATE	2-7
	2.7.1 FREQUENCY HIGH	2-7
2.8	USER	2-7
	2.8.1 FLOW OUT OF RANGE	2-7
	2.8.2 FAN	2-8
	2.8.3 SERVO DIFFERENTIAL PRESSURE	2-9
	2.8.4 CONTROL SETTINGS	2-9
2.9	FLOW SENSOR	2-10
	2.9.1 VT MISMATCH	2-10
	2.9.2 TURN FLOW SENSOR	2-10
2.10	POWER ALARM	2-11
2.11	GAS SUPPLY	2-12
	2.11.1 OXYGEN & AIR SUPPLY	2-12
	2.11.2 OXYGEN SUPPLY	2-12
	2.11.3 AIR SUPPLY	2-12
2.12	INOPERATIVE	2-13
	2.12.1 TECHNICAL FAULT 1	2-13
	2.12.2 TECHNICAL FAULT 2	2-14
	2.12.3 TECHNICAL FAULT 3	2-14
	2.12.4 TECHNICAL FAULT 4	2-14
	2.12.5 TECHNICAL FAULT 5	2-15
	2.12.6 TECHNICAL FAULT 7	2-16
	2.12.7 TECHNICAL FAULT 8	2-16
	2.12.8 TECHNICAL FAULT 12	2-17
	2.12.9 TECHNICAL FAULT 14	2-18
	2.12.10 TECHNICAL FAULT 15	2-18
	2.12.11 TECHNICAL FAULT 101	2-19
	2.12.12 TECHNICAL FAULT 103	2-19

2 ALARM SYSTEM**2.1 GLOSSARY****F****MAJOR FAULT**

When this category of alarm occurs the unit will switch to the AMBIENT MODE which means that the expiration valve is open and the ambient valve will be used for inspiration. The instrument must be switched off and on again to clear this alarm (call Service). Special functions like the calibration task will be terminated immediately in the case of such an alarm. The BUZZER cannot be stopped by the 2-Min key.

H**HIGH PRIORITY ALARM**

When this category of alarm occurs, the unit will switch to the AMBIENT MODE until the alarm disappears. The unit will then continue to operate in the previous USER SELECTED MODE. Special functions, like the calibration task, will be terminated immediately in the case of such an alarm. The BUZZER cannot be stopped by the 2-Min key.

All other alarms

The operation of the ventilator is not affected by these alarms. The buzzer can be silenced by depressing the 2-min key and the alarm condition will clear when the problem has been solved.

2.2 HIGH PRESSURE

Description	The patient pressure has increased to a level above the 'p-Max' setting.
Priority	H(F)
Occurs if	<p>(H) the patient pressure has increased to a level above the 'p-Max' setting. The ventilator will immediately cease flow to the patient and allow expiration to the adjusted PEEP level. A new inspiration is only supplied after the pressure has decreased below the potentiometer setting.</p> <p>(F) after 5 seconds the patient pressure is still above the 'p-Max' setting, then the alarm TECHNICAL FAULT 103 (F) will be activated.</p>
Cleared when	the pressure is lower than 'p-max' setting within 3 seconds.
Inhibited by	TECHNICAL FAULT 103
Generated when	'p-Max' is set lower than the patient pressure.

2.3 DISCONNECTION

2.3.1 DISCONNECTION - VENTILATOR SIDE

Description	A disconnection is detected between the ventilator and the flow sensor.
Priority	-
Occurs if	$V_{T \text{ insp}} < (0.5 * V_{T \text{ servo}})$ <p>The measured volume at the flow sensor during inspiration is less than half the measured volume leaving the servo for two breaths in a row.</p>
Cleared when	$V_{T \text{ servo}} < 200\text{ml} \text{ or one breath at } V_{T \text{ insp}} > (0.5 * V_{T \text{ servo}}).$
Inhibited by	TURN FLOW SENSOR alarm $V_{T \text{ servo}} < 200\text{ml}$
Generated by	disconnection of any tube between the ventilator and the flow sensor.

2.3.2 DISCONNECTION - PATIENT SIDE

Description	A disconnection is detected between the flow sensor and the patient.
Priority	-
Occurs if	$V_{T\ exp} < 0.125 * V_{T\ servo}$ The measured volume at the flow sensor during exhalation is less than 1/8th of the volume leaving the servo for two breaths in a row.
Cleared if	<ul style="list-style-type: none"> - $V_{T\ servo} < 200\text{ml}$ or one breath at $V_{T\ exp} > (0.125 * V_{T\ servo})$. - The alarm 'TURN FLOW SENSOR' is active - The alarm 'DISCONNECTION VENTILATOR SIDE' is active.
Inhibited by	<ul style="list-style-type: none"> - TURN FLOW SENSOR alarm - $V_{T\ servo} < 200\text{ml}$ - DISCONNECTION VENTILATOR SIDE alarm
Generated by	disconnection of any tube between the flow sensor and the patient. (The flow sensor has to stay connected!)

2.3.3 LOSS OF PEEP

Description	PEEP is too low
Priority	-
Occurs if	for 10 seconds, the patient pressure is lower than the PEEP setting minus 3 mbar.
Cleared when	measured PEEP is equal with PEEP setting minus 3 mbar.
Inhibited by	PEEP/CPAP < 4mbar
Generated by	-

2.4 APNEA

2.4.1 FLOW APNEA

Description	No breathing is detected.
Priority	-
Occurs if	after the beginning of the last expiration, no inspiration and no new expiration is measured by the Flow Sensor ~ 20 sec in version 30, 31 and 32 ~ 20 or 40 sec in version 33. This alarm sets the expired volume $V_{T\ exp}$ to '0 ml'.
Cleared if	breathing is detected.
Inhibited by	-
Generated by	SIMV mode: f-SIMV = 0,5 , PEEP = 0mbar, Trigger = -10mbar.

2.4.2 FAIL TO CYCLE

Description	No inspiration/expiration change is detected.
Priority	-
Occurs if	20 or 40 secs after the last inspiration no expiration and no new inspiration is detected. The control system will be used to detect this alarm. This alarm sets the expired volume $V_{T\ exp}$ to '0 ml'.
Cleared when	Inspiration/expiration is detected.
Inhibited by	APNEA alarm
Generated by	SPONT mode: Trigger -15mbar, PEEP = 0 mbar. Disconnect the flow sensor and breath through it using a mouthpiece (in order not to make an apnea).

2.5 EXPIRED MINUTE VOLUME

2.5.1 EXPIRED MINUTE VOLUME - LOW/HIGH

Description	Expired Minute Volume different than the setting.
Priority	-
Occurs if	the measured expired minute volume is lower than the value which is set by the 'Vexp/min MIN' potentiometer.

Cleared if measured exp. volume is higher than 'Vexp/min MIN'.

Inhibited by -

Generated by increasing the potentiometer 'MIN' to more than the expired minute volume.

2.6 OXYGEN CONCENTRATION

2.6.1 OXYGEN CONCENTRATION - LOW/HIGH

Description Oxygen level is out of range .

Priority -

Occurs if the O₂ Cell measured value is more than 1% higher or lower than the adjusted alarm-potentiometer.

Cleared when the measured oxygen level is in the range of the potentiometer setting.

Inhibited by

- all Gas Supply Alarms
- the O₂-Calibration and the O₂ Flush
- oxygen knob on position 'No O₂ Cell' and 'oxygen' LED is blinking.
- (Version 33) resetting the O₂-knob inhibited for 30 secs. (the system is flushing until the new setting is reached) .

Generated when the 'O₂' potentiometer is higher or lower than the measured value shown on the display.

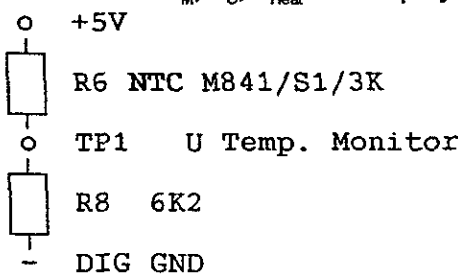
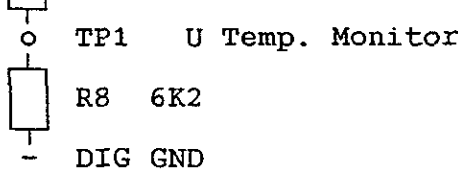
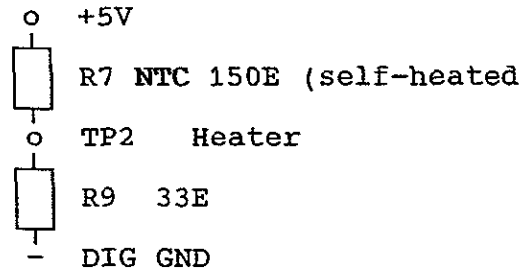
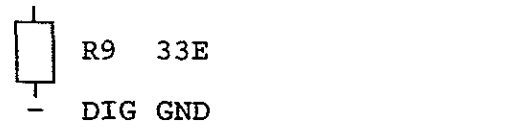
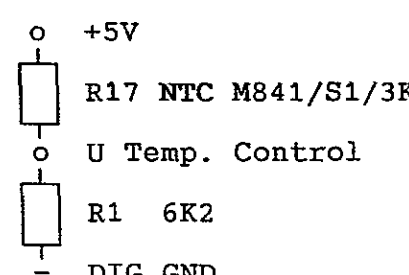
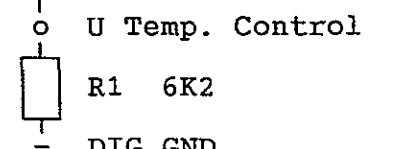
2.7 HIGH RATE**2.7.1 FREQUENCY HIGH**

Description	The measured frequency is higher than the setting of the potentiometer 'f-Max'.
Priority	-
Occurs if	the total frequency (Spont breaths plus the machine given breaths per minute) is higher than the setting of the 'f-Max' potentiometer.
Cleared if	the total frequency is lower than 'f-Max'.
Inhibited by	-
Generated by	decreasing 'f-Max' in CMV or SPONT mode!

2.8 USER**2.8.1 FLOW OUT OF RANGE**

Description	The servo is requested to create a flow greater than 3 l/sec.
Priority	-
Occurs if	during controlled ventilation a flow higher than 3 l/sec is demanded (the flow will be limited to 3 l/sec). The breathing frequency, the tidal volume and the I:E ratio influence the flow. (Attention: sigh cycles are 1.5 times higher than tidal volume)
Cleared if	flow is in range
Inhibited by	-
Generated by	settings: high frequency, high tidal volume, short inspiration.

2.8.2 FAN

Description	The fan does not cool the NTC-resistor.
Priority	-
Occurs if	<ul style="list-style-type: none"> - The fan filter is dirty, the fan does not work or its test circuit is defective. - $T_M \geq T_C + 2.4^\circ\text{C}$ - $T_{\text{Heat}} > [(T_C * 1.1) + 22^\circ\text{C}]$ <p>Note: all values T_M, T_C, T_{Heat} are displayed in Test 16.</p>
T_M : (Monitor Board)	
Monitor selector Pos. 4 (*0.1)	
T_{Heat} : (Monitor Board)	
Monitor selector Pos. 9 (*0.1)	
T_C : (Control Board)	
Monitor selector Pos. 5 (*0.1)	
Cleared when	the NTCs values are in range
Inhibited by	<p>the first hour after switching on the respirator, the 'dirty filter alarm' is inhibited.</p> <p>For service, the 'Fan alarm' can be deactivated by quickly switching the DIP switch no. 8 (rearside) ON and OFF. While the fan supervision is deactivated, the USER LED flashes.</p>
Generated by	stopping the fan.
Consult Testsoftware	Test 16

2.8.3 SERVO DIFFERENTIAL PRESSURE

Description	Tank pressure is low.
Priority	H
Occurs if	a) the Servo valve differential pressure is less than 150 mbar for more than 3 secs. b) the tank pressure dose not increase by at least 20 mbar/sec starting a new exhalation or if the 'gas supply' alarm is active.
Cleared when	differential pressure is higher than 150 mbar
Inhibited by	-
Generated by	-

2.8.4 CONTROL SETTINGS

Description	One or more of the potentiometers is in the red area of the scale. Those potentiometer settings on the Frontpanel which have their LED's flashing are set out of the allowed range.
Priority	-
Occurs if	f-SIMV > 60 (if switch #4 on FP board is on) f-CMV < 5 Insp. < 10% Plateau/Exp > 80% Trigger = off in SIMV, PCV-SIMV, SPONT, MMV PEEP > 100 mbar (if switch #4 on FP board is on) P-insp > 100 mbar (if switch #4 on FP board is on)
Cleared if	all settings are in the allowed range.
Inhibited by	-
Generated by	wrong setting of a potentiometer as described.

2.9 FLOW SENSOR

2.9.1 VT MISMATCH

Description	The flow sensor signal is out of range
Priority	-
Occurs if	the voltage level of the A/D converter channel 7 (flow sensor signal) is out of range (-8.3 ... +8.3V)
Cleared if	the flow sensor signal is in allowed range
Generated by	disconnect one flow sensor tubing

2.9.2 TURN FLOW SENSOR

Description	Flow sensor is in the reversed position.
Priority	-
Occurs if	$V_{T \text{ exp}} < (0.5 * V_{T \text{ servo}})$ The measured volume at the flow sensor during expiration is less than half the measured volume leaving the servo for 5 breaths in a row. Note: The flow sensor volume, which is used for the comparison is not influenced by FAIL TO CYCLE or FLOW APNEA alarm. This alarm suppresses both DISCONNECTION alarms and both MISMATCH alarms. In version 30: This alarm is only active, if $V_{T \text{ servo}} > 200\text{ml}$.
Cleared when	$V_{T \text{ exp}} > (0.5 * V_{T \text{ servo}})$
Generated by	turning the flow sensor.

2.10 POWER ALARM

Occurs if:

1. Over- and undervoltage of the 5V supply ($\pm 5\%$) . Detected on the Supervisor Board. Also detected by loss of external power.
2. TECHNICAL FAULT 4 sets off the power alarm: The CP finds a communication error to FP (e.g. in case of a FP failure) . Consult the description of TECHNICAL FAULT 4.
3. System EPROM test: The processor detects a bad EPROM (tested only once after the power is on). This test is made in the CP, FP and in the MI (Mixer). In the case of failure, the processor stops working.
4. TECHNICAL FAULT 15 sets off the power alarm: 100 kHz clock or CP board failure (timer failure).
5. TECHNICAL FAULT 5 sets off the power alarm: Over- and undervoltage of the $\pm 15V$ supply (measured on the Monitor Board, R1, R2,R3,R4) Consult the description of TECHNICAL FAULT 5 .
6. TECHNICAL FAULT 8 sets the power alarm. One of the three 8bit AD Converter is out of range (measured on the Monitor Board and Control Board using the voltage Ref 5V) Consult the description of TECHNICAL FAULT 8.
7. Double Buzzer cable defective or unplugged.
8. Software Compatibility Test fails. The software number (e.g. 33) must be the same on all three EPROMs. Find a software overview in section 15 of this manual.

2.11 GAS SUPPLY

2.11.1 OXYGEN & AIR SUPPLY

Description	The oxygen and air supply pressure are less than the input level.
Priority	H (if INTERNAL PRESSURE LOW alarm is on)
Occurs if	the oxygen and air supply pressure are below approx. 1.9 bar. OXYGEN SUPPLY and AIR SUPPLY alarm are active.
Cleared if	the flow through the used mixer valve(s) are accepted.
Inhibited by	-
Generated by	disconnecting both gas supplies.

2.11.2 OXYGEN SUPPLY

Description	Oxygen supply pressure is less than the accepted input level.
Priority	H
Occurs if	the oxygen supply pressure is less than approx. 1.9 bar.
Cleared when	oxygen supply pressure is greater than approx. 1.9 bar.
Inhibited by	OXYGEN & AIR SUPPLY alarm
Generated by	disconnection of the oxygen supply.

2.11.3 AIR SUPPLY

Description	The air supply pressure is less than the accepted input level.
Priority	H
Occurs if	the air supply pressure is less than approx. 1.9 bar
Cleared when	the air supply pressure is greater than approx. 1.9 bar.
Inhibited by	OXYGEN & AIR SUPPLY alarm
Generated by	disconnecting the air supply.

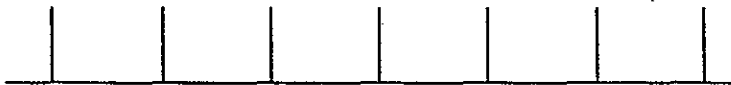
2.12 INOPERATIVE

2.12.1 TECHNICAL FAULT 1

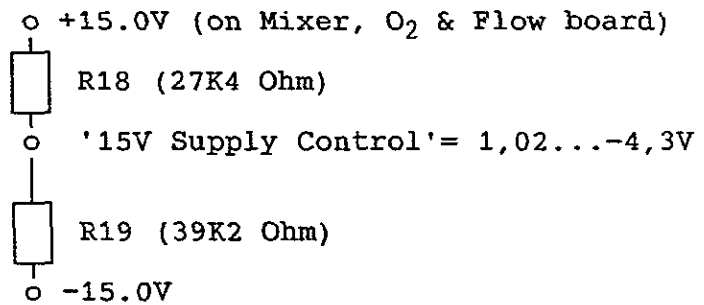
Description 12 bit A/D converter failure

Priority **H**

Occurs if 1) The 12 bit A/D converter on the Analog I/O Board does not work properly: the control signal "ADC STATUS COMPLETE" on the CP Board, pin 25b does not change its level from '1' to '0' within 625 usec.



2) The signal '15V Supply Control' is out of range:



Cleared when A/D convertor works properly

Inhibited by -

Consult - Testsoftware 21 - 24

2.12.2 TECHNICAL FAULT 2

Description	Error in servo control circuit.
Priority	F
Occurs if	the servo control system does not work properly: the signal "SERVO ERROR" from the Flow Control Board (test point 14) stays high for more than 5 seconds continuously.
Cleared if	
Inhibited by	TECHNICAL FAULT 103 or TECHNICAL FAULT 5
Generated by	pulling out connector #22 (servo control cable) or #24 (Servo power) on the motherboard.

2.12.3 TECHNICAL FAULT 3

Description	The NICAD battery is low.
Priority	-
Occurs if	the signal "ACCU CONT" from the Supervisor Board reads low, because the NICAD battery is low.
Cleared when	The NICAD battery in order.
Inhibited by	-
Generated by	-

2.12.4 TECHNICAL FAULT 4

Description	Communication error between the two system processors. The CP is checked every second.
Priority	H
Occurs if	the frontpanel processor finds communication failure (probably CP failure).
Cleared when	communication is correct.
Inhibited by	-
Generated by	pulling out the CP board
Consult Testsoftware	Test 17, 18, 19

2.12.5 TECHNICAL FAULT 5

Description

±15V Supply Failure.

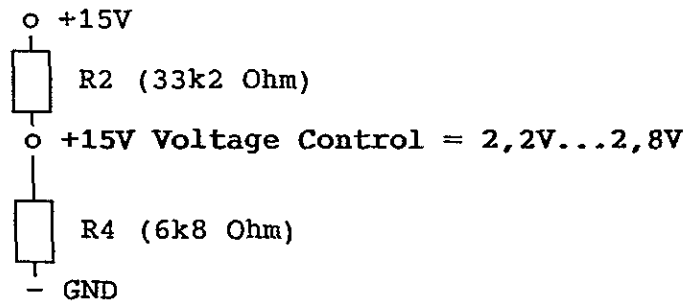
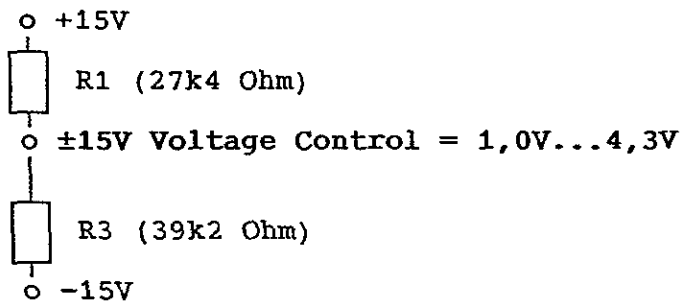
15V supplies are incorrect (measured with the voltage dividers R1,R2,R3,R4 on the Monitor Board). The power alarm LED will be activated.

Priority

H

Occurs if

the readings are out of range



Cleared when

the 15V readings are in the limits.

Inhibited by

TECHNICAL FAULT 103 or TECHNICAL FAULT 2

Generated by

short wire of R1, R2, R3 or R4.

Consult

Testsoftware Test 16

2.12.6 TECHNICAL FAULT 7

Description	Keyboard failure.
Priority	H
Occurs if	there is a failure in the keyboard circuit on the Monitor or on the Control Board.
Cleared if	-
Generated by	-
Consult	Testsoftware Test 5.0

2.12.7 TECHNICAL FAULT 8

Description	One of the three 8bit AD converters is out of range (measured on the Monitor Board and Control Board using the voltage Ref 5V) The power alarm will be a activated.
Priority	H
Occurs if	-
Cleared if	-
Inhibited by	-
Generated by	-
Consult	Test 1-10

2.12.8 TECHNICAL FAULT 12

1. Description The **gas inlet valve(s)** cannot be opened or closed by the mixer. An **overly high gas inlet pressure** will produce the same effect.
Priority **H**
Occurs if the valves are not working properly or the gas inlet pressure is greater than 6 bar.
Generated by Pressing down the cylinder(s) of the valve(s)

2. Description The Control Processor detects a **communication error** between itself and the Mixer Processor.
Priority **H**

3. Description The **tank pressure** has increased to over 503 mbar or 'Error P Tank' signal is not generated on the Mother Board.
Priority **F**
Occurs if This error occurs mainly during "O₂ Flush" of "O₂ Cal".

4. Description (Only valid for Mixer Software Version RMI0300): During the **flow calibration**, "Cal Flow", the volume comparison between the Mixer and the Servo Valve is out of the tolerance.
Priority **F**
Occurs if This error occurs only during the flow calibration procedure.
Cleared when the mixer software is replaced. The improved software is called RMI0301.
Consult Testsoftware Test 25, 48

2.12.9 TECHNICAL FAULT 14

Description	Status error. The frontpanel processor detects that the CP does not work.
Priority	H
Occurs if	the I:E-status of the CP is controlled by the frontpanel processor. The alarm will be active, if after the beginning of the last inspiration, no expiration and no new inspiration occurs, within ~ 25 secs: version 30 ~ 30 secs: version 31, 32 and 33.
Cleared if	a inspiration or expiration is detected.
Inhibited by	APNEA: FAIL TO CYCLE alarm
Generated by	-
Consult	Testsoftware, Simulated in Test 20

2.12.10 TECHNICAL FAULT 15

Description	The 100kHz System Clock, generated on the Control Board, is out of range. This clock is for the serial communication between the Front Panel (Monitor and Control Board and the frontpanel processor. The Processor Clock is 12MHz.
Priority	H
Occurs if	System clock is lower than 95kHz or higher than 105kHz
Cleared when	clock is within range.
Inhibited by	-
Generated by	-

2.12.11 TECHNICAL FAULT 101

Description	The tank pressure is low.
Priority	H
Occurs if	servo valve differential pressure less than 150mbar for at least 3 seconds.
Cleared when	the differential pressure is greater than 150 mbar
Inhibited by	if a GAS SUPPLY alarm occurs and then an INTERNAL PRESSURE LOW alarm occurs, the ventilator switches into AMBIENT mode as soon as the tank is empty.
Generated by	<ul style="list-style-type: none"> a) opening the tank overpressure valve with your finger and letting the tank pressure drop. b) disconnecting of the gas supplies.

2.12.12 TECHNICAL FAULT 103

Description	Duration of the patient 'HIGH PRESSURE' alarm is too long.
Priority	F
Occurs if	the 'HIGH PRESSURE' alarm is longer than 5 seconds.
Cleared if	
Inhibited by	TECHNICAL FAULT 5 or TECHNICAL FAULT 2
Generated by	-

SECTION 3 POWER SUPPLY

Used with marked Software Version

30	31	32	33	
----	----	----	----	--

3	POWER SUPPLY	3-2
3.1	DESCRIPTION OF THE POWER SUPPLY	3-2
3.1.1	Exchange of the mains fuses	3-2
3.1.2	Mains Voltage selection	3-2
3.1.3	Secondary fuses exchange	3-3
3.1.4	Fan filter exchange	3-3
	BLOCK SCHEMATIC OF THE POWER SUPPLY	3-4
614061	Block Schematic	3-4
610377	Power Supply Wiring	3-5
	POWER SUPPLY BOARD	3-6
604700	Schematic Diagram	3-6
153300	Board Drawing	3-7

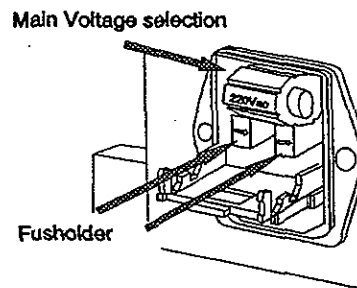
3 POWER SUPPLY

3.1 DESCRIPTION OF THE POWER SUPPLY

The power supply of the AMADEUS is located on the right side of the ventilator. The power supply contains only one board, the Voltage Regulator board, and along with a toroid transformer, produces the required voltages. The voltages are +5V DC for the digital electronics and $\pm 15V$ DC for the analog electronics and valve control.

The power supply also houses the hour meter, the power plug and the ON/OFF switch, all of which are located at the rear of the ventilator. The power supply is protected from high voltages by two sets of fuses. The primary fuses are located inside the voltage selector in the power plug. The secondary fuses are located on the Voltage Regulator board.

3.1.1 Exchange of the mains fuses (Figure 3_1)



Use a screw driver to open the power plug enclosure. Pull out the fuse holders to exchange the fuses.

Primary fuses :
Two 0.8A TT for 220V
Two 1.6A TT for 110V

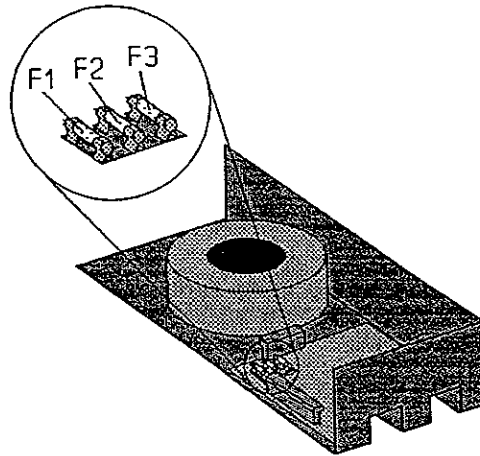
fig.3_1

3.1.2 Mains Voltage selection (Figure 3_1)

Remove the mains voltage selector. Put it back with the chosen voltage.

Note: Do not turn the voltage selector without removing.

3.1.3 Secondary fuses exchange (Figure 3_2)



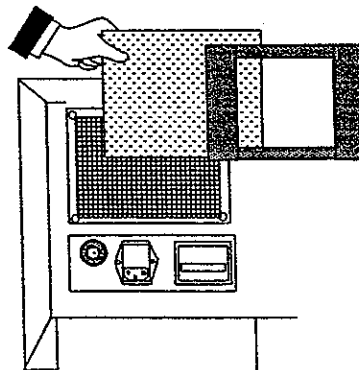
Remove the Top Enclosure of the unit to exchange the fuses.

fig.3_2

Secondary fuses:

- F1 3.15A T (+ 5V Supply)
- F2 2.5A T (+ 15V Supply)
- F3 1.25A T (- 15V Supply)

3.1.4 Fan filter exchange (Figure 3_3)



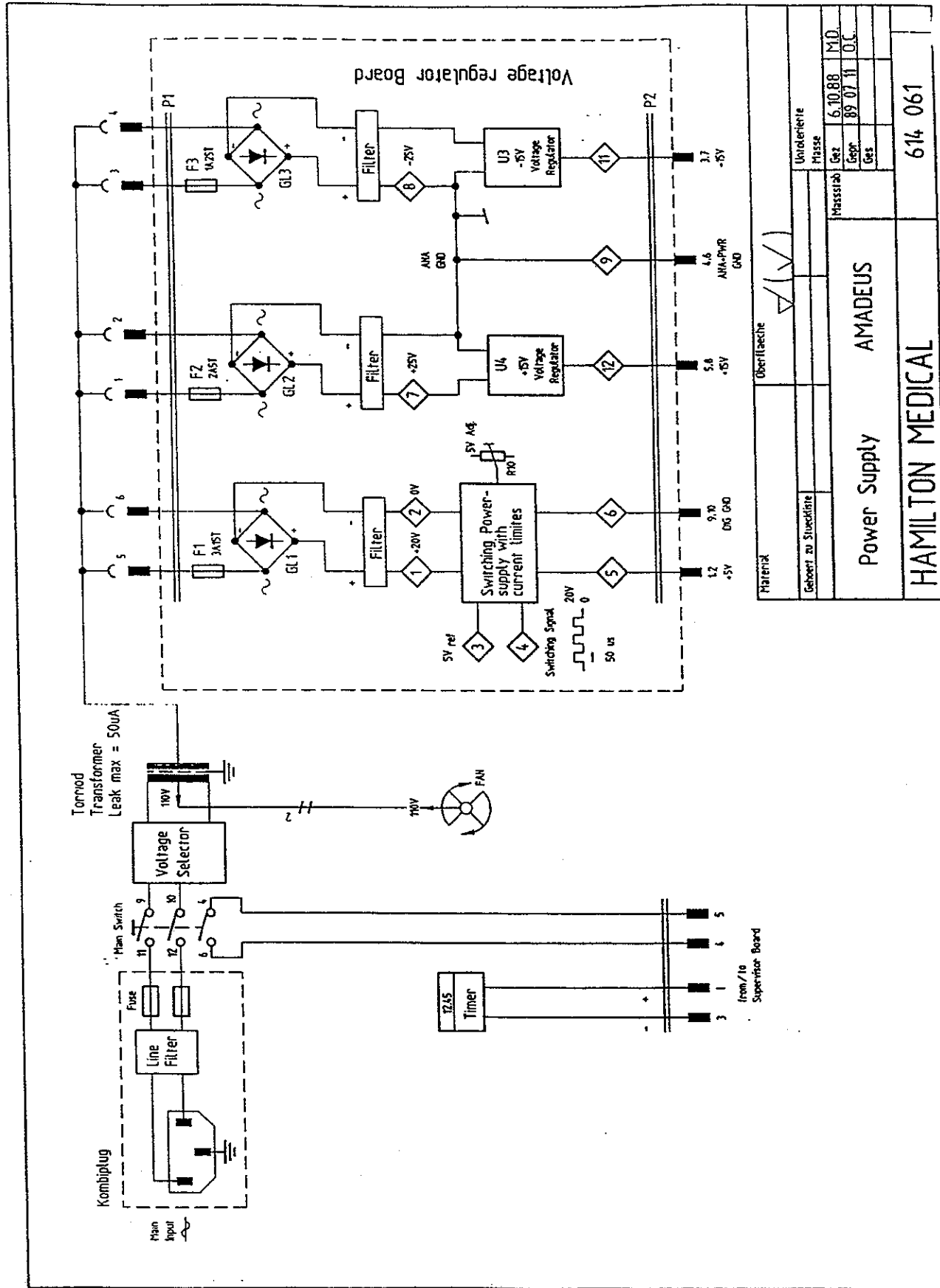
Remove the cover and change the filter.

fig.3_3

SECTION 3 POWER SUPPLY

Used with marked Software Version

30	31	32	33
----	----	----	----



Material		Oberflaeche	
Gehoert zu Steckkarte		Unorientierte Masse	
Power Supply		Massstab	M.D.
HAMILTON MEDICAL		Gez.	6.10.88
		Gez.	89.07.11
		Gez.	O.C.
		614 061	

lesen koennen. Mit als dem jeweiligen Maassstab zu suchen.
 anerkenn. Das Eigentum und das Urheberrecht verbleibt uns
 Ohne unsere schriftliche Genehmigung duferen die Zeichnungen
 weder kopiert noch Drittenpersonen zuganglich gemacht werden

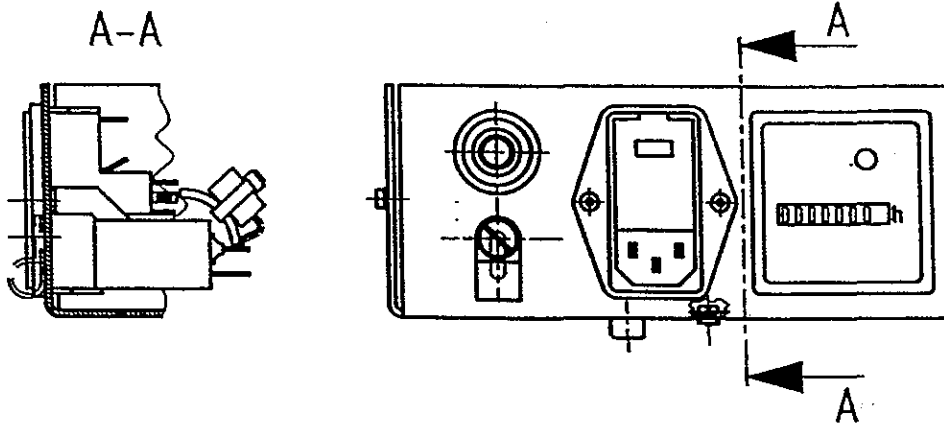
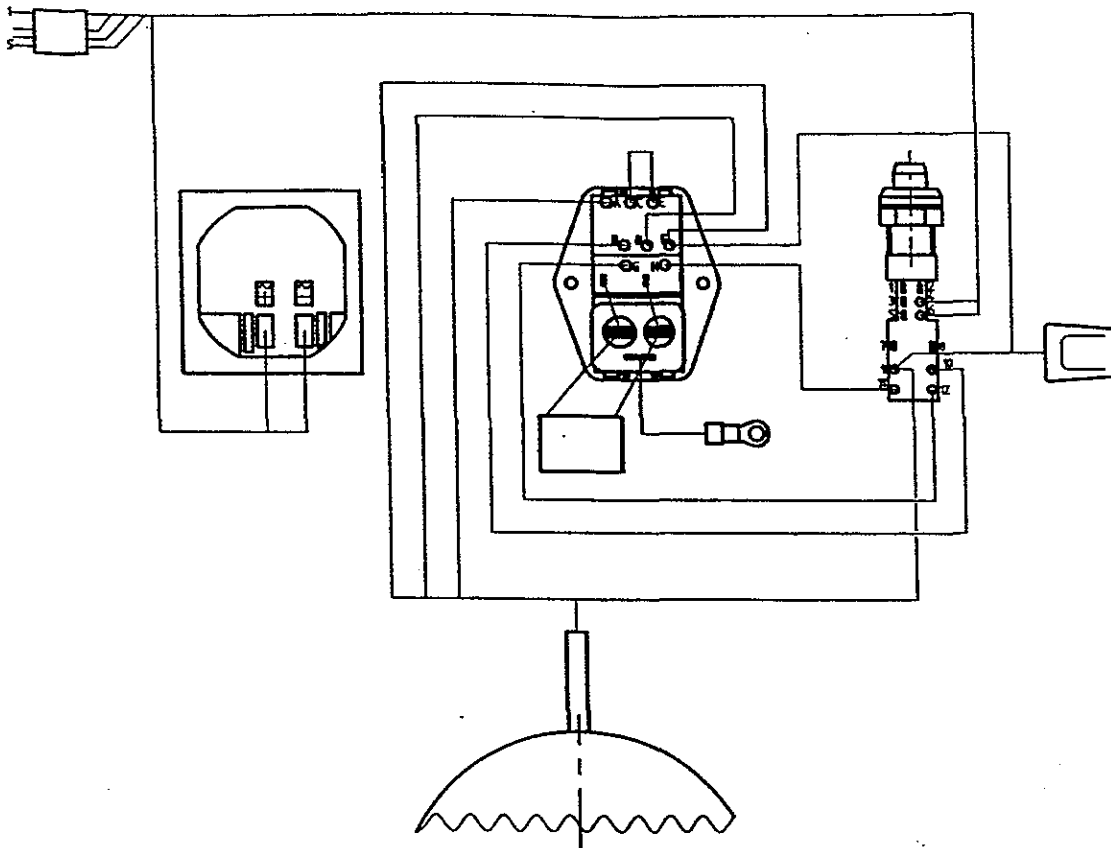
22. 2. 1994 8.01am

SECTION 3 POWER SUPPLY

Used with marked Software Version

30	31	32	33
----	----	----	----

Diese Zeichnung gilt als dem jeweiligen Inhaber persönlich anvertraut. Das Eigentum und das Urheberrecht verbleibt uns. Ohne unsere schriftliche Genehmigung dürfen die Zeichnungen weder kopiert noch Drittpersonen zugänglich gemacht werden.



Material

Oberflaeche
 ✓(✓)

00
 5589
 Rev. Aend-Nr

Power Supply AMADEUS

Untolerierte Masse			
Massstab	Gez	1994-01-13	F.J.
	Gepr	1994-02-21	/m.
	Gepl	1994-02-16	FAJ02

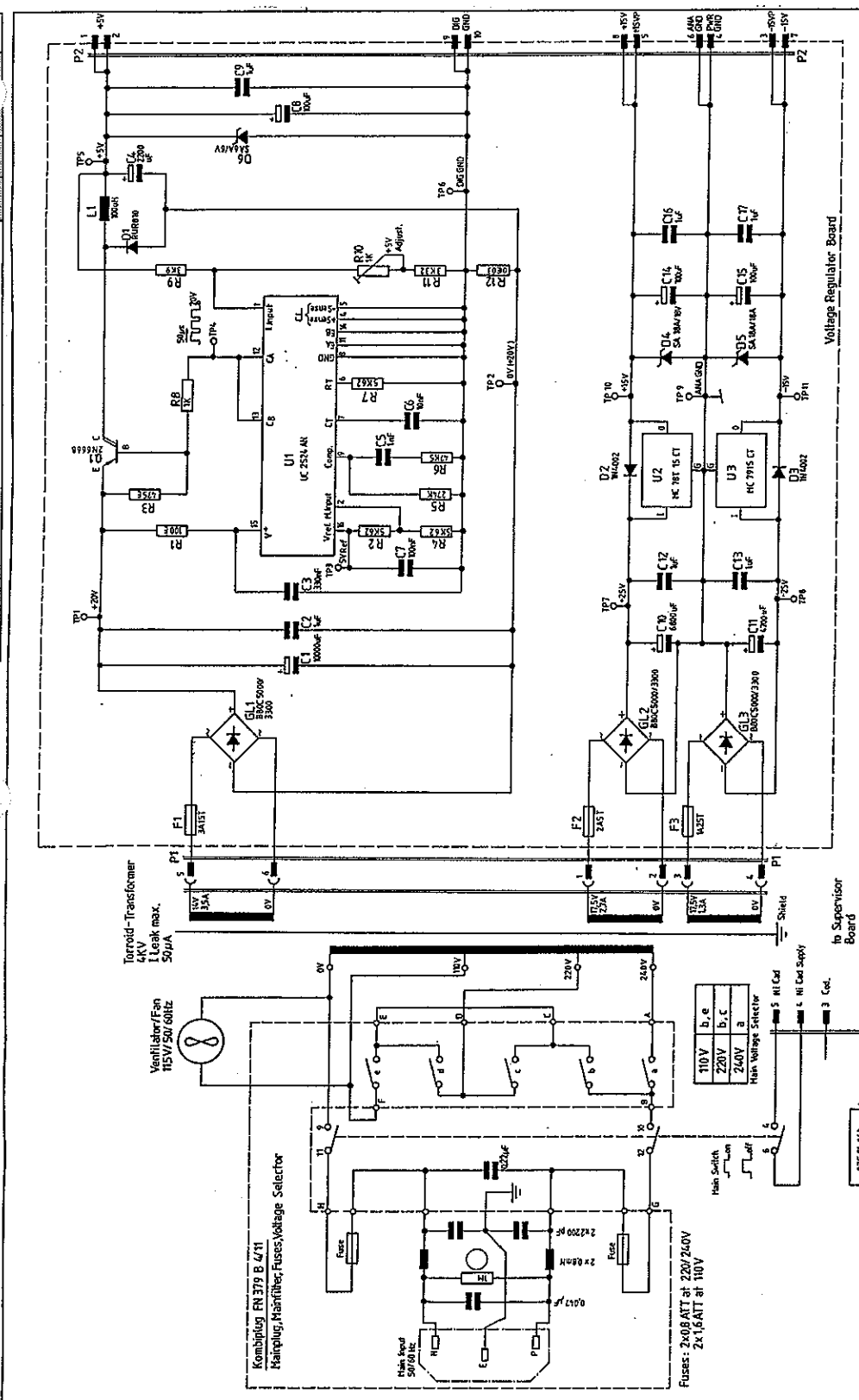
A E N D HAMILTON MEDICAL

610377

22.2.1994 8.01am

SECTION 3 POWER SUPPLY

Used with manual



Alternspannungsbereich	0,5...3	>3...4	>4...20	>20...100	>100...1000	>1000...2000
Leistung	2,0/0,5	2,0/0,5	2,0/1	2,0/1,5	2,0/2	2,0/3
Leistung	2,0/0,5	2,0/1	2,0/2	2,0/3	2,0/4	2,0/5
Leistung	2,0/0,5	2,0/1	2,0/2	2,0/3	2,0/4	2,0/5
Leistung	2,0/0,5	2,0/1	2,0/2	2,0/3	2,0/4	2,0/5

General Information: L53 301

Model: L53 301

Part No.: 15-3-88 / 22

Rev.: 200-2-88

QC2

Power Supply AMADEUS

HAMILTON MEDICAL

604 700

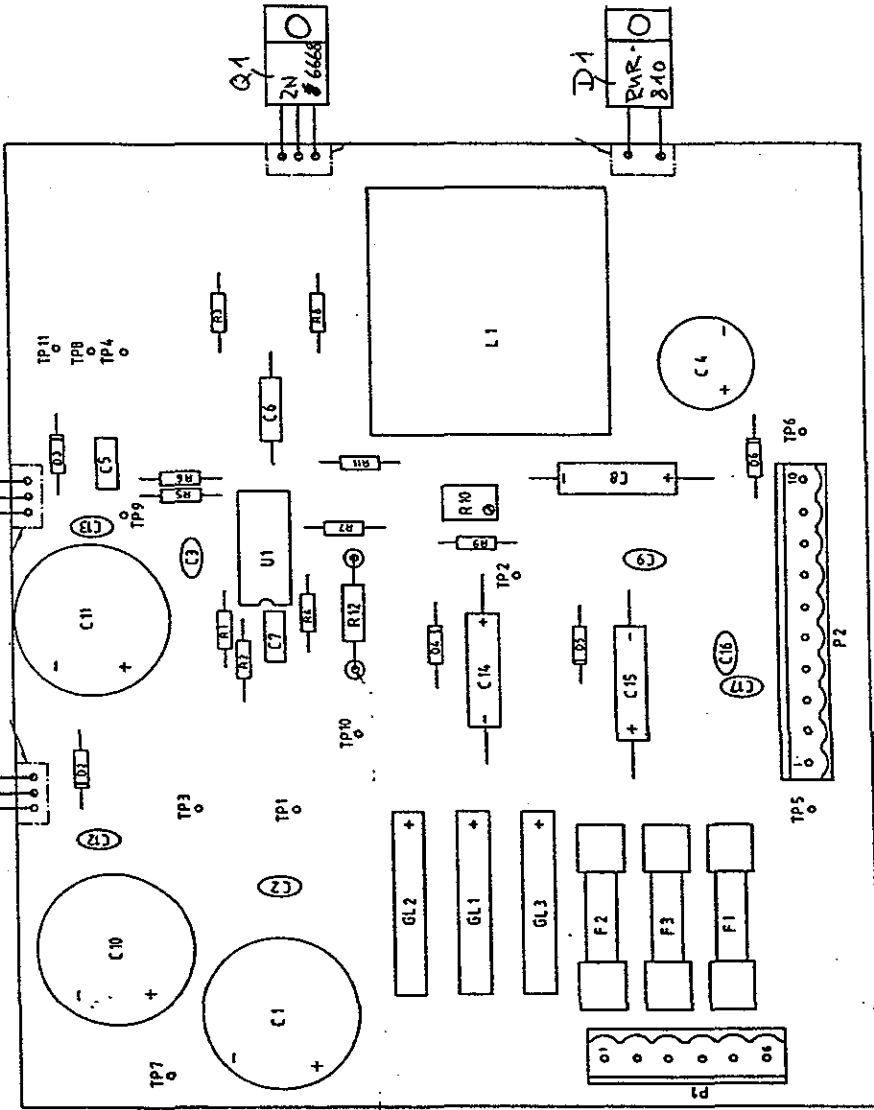
Alle Angaben sind ohne Gewähr zu verstehen.
Für Änderungen sind die Zeichnungen maßgebend.
Die Ausführung ist dem Anwender überlassen.
Die Ausführung ist dem Anwender überlassen.
Die Ausführung ist dem Anwender überlassen.

SECTION 3 POWER SUPPLY

Used with marked Software Version

30	31	32	33
----	----	----	----

Allgemeincharakteristiken		Nennleistung	
U ₁	U ₂	> 315 ... 1000	> 315 ... 1000
2.100	2.000	2.00	2.00
2.100	2.000	2.01	2.015
2.100	2.000	2.02	2.03
2.100	2.000	2.03	2.04
2.100	2.000	2.04	2.05
2.100	2.000	2.05	2.06
2.100	2.000	2.06	2.07
2.100	2.000	2.07	2.08
2.100	2.000	2.08	2.09
2.100	2.000	2.09	2.10
2.100	2.000	2.10	2.11
2.100	2.000	2.11	2.12
2.100	2.000	2.12	2.13
2.100	2.000	2.13	2.14
2.100	2.000	2.14	2.15
2.100	2.000	2.15	2.16
2.100	2.000	2.16	2.17
2.100	2.000	2.17	2.18
2.100	2.000	2.18	2.19
2.100	2.000	2.19	2.20
2.100	2.000	2.20	2.21
2.100	2.000	2.21	2.22
2.100	2.000	2.22	2.23
2.100	2.000	2.23	2.24
2.100	2.000	2.24	2.25
2.100	2.000	2.25	2.26
2.100	2.000	2.26	2.27
2.100	2.000	2.27	2.28
2.100	2.000	2.28	2.29
2.100	2.000	2.29	2.30
2.100	2.000	2.30	2.31
2.100	2.000	2.31	2.32
2.100	2.000	2.32	2.33
2.100	2.000	2.33	2.34
2.100	2.000	2.34	2.35
2.100	2.000	2.35	2.36
2.100	2.000	2.36	2.37
2.100	2.000	2.37	2.38
2.100	2.000	2.38	2.39
2.100	2.000	2.39	2.40
2.100	2.000	2.40	2.41
2.100	2.000	2.41	2.42
2.100	2.000	2.42	2.43
2.100	2.000	2.43	2.44
2.100	2.000	2.44	2.45
2.100	2.000	2.45	2.46
2.100	2.000	2.46	2.47
2.100	2.000	2.47	2.48
2.100	2.000	2.48	2.49
2.100	2.000	2.49	2.50
2.100	2.000	2.50	2.51
2.100	2.000	2.51	2.52
2.100	2.000	2.52	2.53
2.100	2.000	2.53	2.54
2.100	2.000	2.54	2.55
2.100	2.000	2.55	2.56
2.100	2.000	2.56	2.57
2.100	2.000	2.57	2.58
2.100	2.000	2.58	2.59
2.100	2.000	2.59	2.60
2.100	2.000	2.60	2.61
2.100	2.000	2.61	2.62
2.100	2.000	2.62	2.63
2.100	2.000	2.63	2.64
2.100	2.000	2.64	2.65
2.100	2.000	2.65	2.66
2.100	2.000	2.66	2.67
2.100	2.000	2.67	2.68
2.100	2.000	2.68	2.69
2.100	2.000	2.69	2.70
2.100	2.000	2.70	2.71
2.100	2.000	2.71	2.72
2.100	2.000	2.72	2.73
2.100	2.000	2.73	2.74
2.100	2.000	2.74	2.75
2.100	2.000	2.75	2.76
2.100	2.000	2.76	2.77
2.100	2.000	2.77	2.78
2.100	2.000	2.78	2.79
2.100	2.000	2.79	2.80
2.100	2.000	2.80	2.81
2.100	2.000	2.81	2.82
2.100	2.000	2.82	2.83
2.100	2.000	2.83	2.84
2.100	2.000	2.84	2.85
2.100	2.000	2.85	2.86
2.100	2.000	2.86	2.87
2.100	2.000	2.87	2.88
2.100	2.000	2.88	2.89
2.100	2.000	2.89	2.90
2.100	2.000	2.90	2.91
2.100	2.000	2.91	2.92
2.100	2.000	2.92	2.93
2.100	2.000	2.93	2.94
2.100	2.000	2.94	2.95
2.100	2.000	2.95	2.96
2.100	2.000	2.96	2.97
2.100	2.000	2.97	2.98
2.100	2.000	2.98	2.99
2.100	2.000	2.99	3.00



Voltage Regulator Board

HAMILTON MEDICAL

153 300

Diese Zeichnung gilt nur für den jeweiligen Hersteller. Die Fertigung der Bauteile ist dem Hersteller überlassen. Die Fertigung der Bauteile ist dem Hersteller überlassen.

4	THE MOTHERBOARD	4-2
4.1	DESCRIPTION OF THE MOTHERBOARD	4-2
	MOTHERBOARD WITHOUT OPTIONAL PRESSURE SENSOR	4-3
614060	Block Schematic	4-3
604701/1	Schematic Diagram	4-4
604701/2	Schematic Diagram	4-5
153310	Board Drawing	4-6

4 THE MOTHERBOARD

4.1 DESCRIPTION OF THE MOTHERBOARD

The motherboard is mounted on the front of the electronic board rack and provides communication links between the boards. The pressure transducers for the tank, flow sensor, mixer and patient pressures are located on the motherboard.

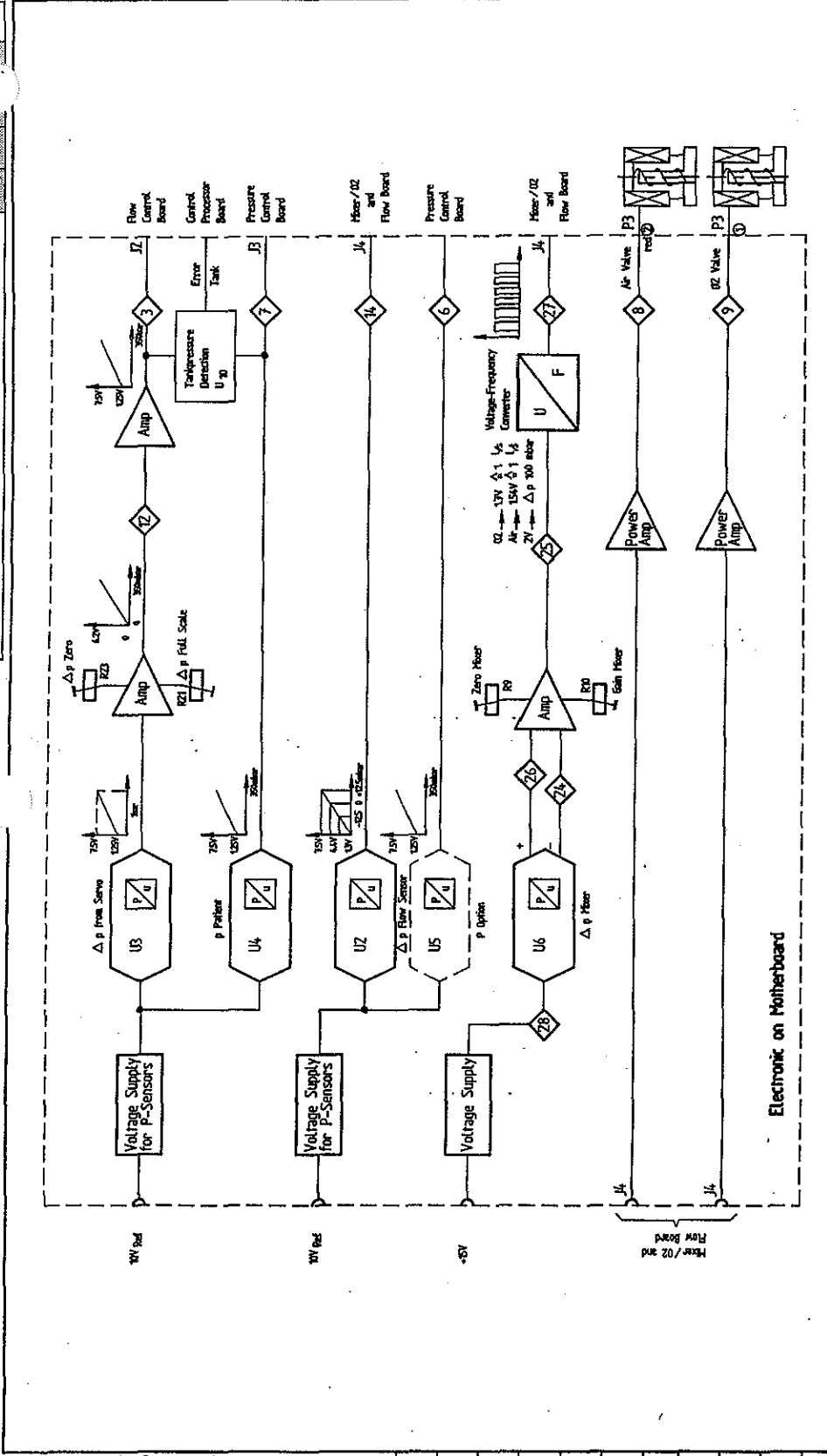
The transducer for the mixer is in the lower right hand corner and the flow sensor transducer is in the centre at the bottom. The two transducers for patient and tank pressures are on top.

The motherboard also contains two sets of adjustment potentiometers. The zero and full scale potentiometers on the left side of transducer V_2 are for adjusting the tank pressure transducer. The zero setting and gain potentiometers in the upper right hand corner are for the mixer.

Pressure Sensor				
	P-Patient P-optional	P-Delta	P-Flow Sensor	P-Mixer
Sensitivity (mV/mbar)	14,5	4,83	200	0,2
Range (mbar)	0 - 345	0 - 1034	±12,5	0 - 330
Maximum Pressure (bar)	1,38	3,1	0,345	1,34

SECTION 4 MOTHERBOARD

Used with master? 3



Diese Zeichnung gilt als dem jeweiligen Inhaber persönlich anvertraut. Das Eigentum und das Urheberrecht verbleibt bei uns. Unsere schriftliche Genehmigung durch die Zeichnungen weder kopiert noch Dritten Personen zugänglich gemacht werden.

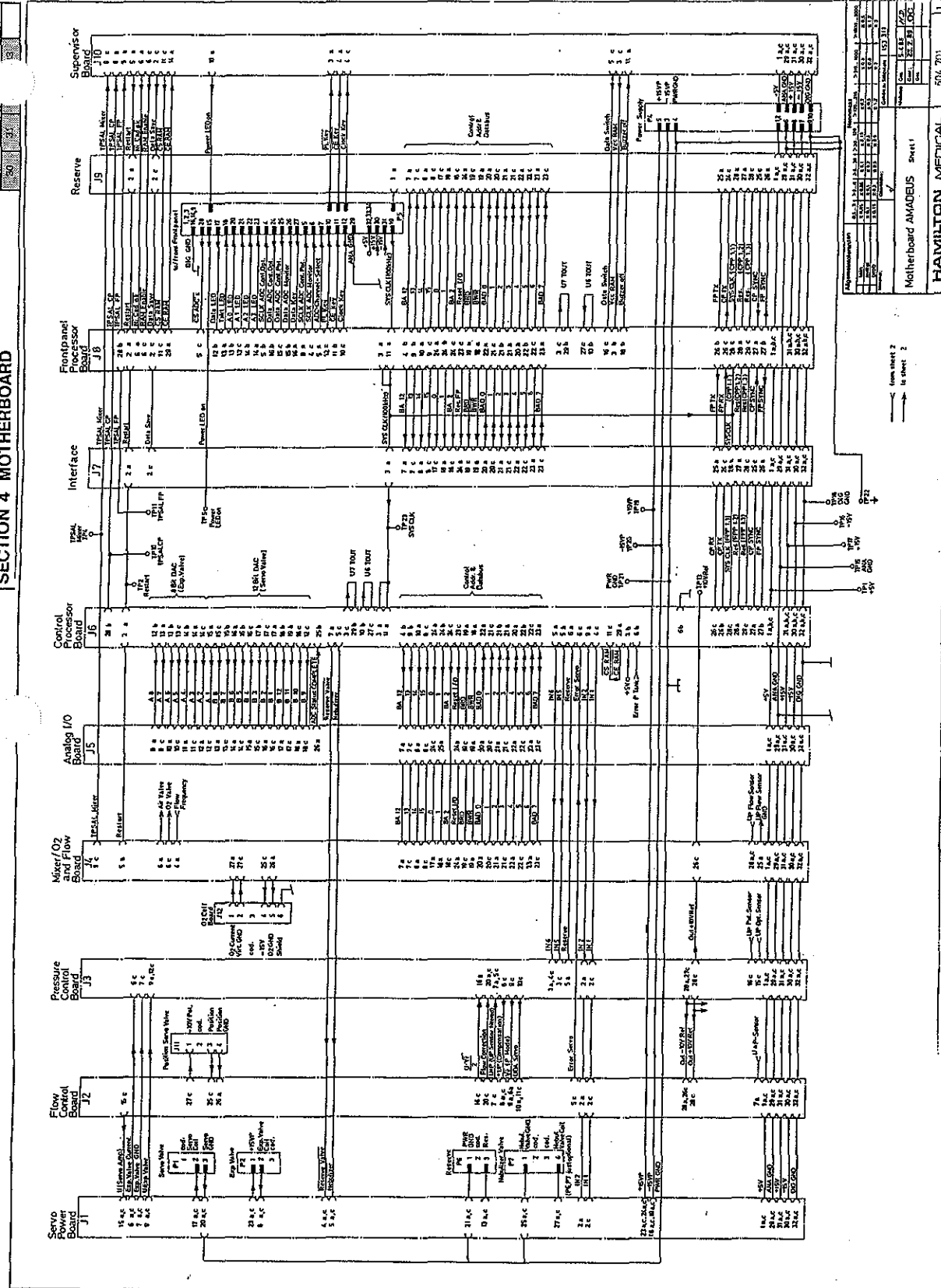
Rev.	01
Part-Nr.	627
Datum	23.7.91
Von	

Material		Oberfläche	
Schoert zu Standard		AVV	
Motherboard		AMADEUS	
HAMILTON MEDICAL		614 060	
22.10.88		M.D.	
31.08.88		I.D.	
07.11.89		G.C.	
07.23.99		G.C.	

HAMILTON MEDICAL AG Service Manual AMADEUS Order-Nr. 610 221 4-3

SECTION 4 MOTHERBOARD

Used with marker 30



Revision History

Rev.	Date	Description
1	1984-08-16	Initial Release

Part Number: 504 701

Manufacturer: HAMILTON MEDICAL

Order No. 610 221

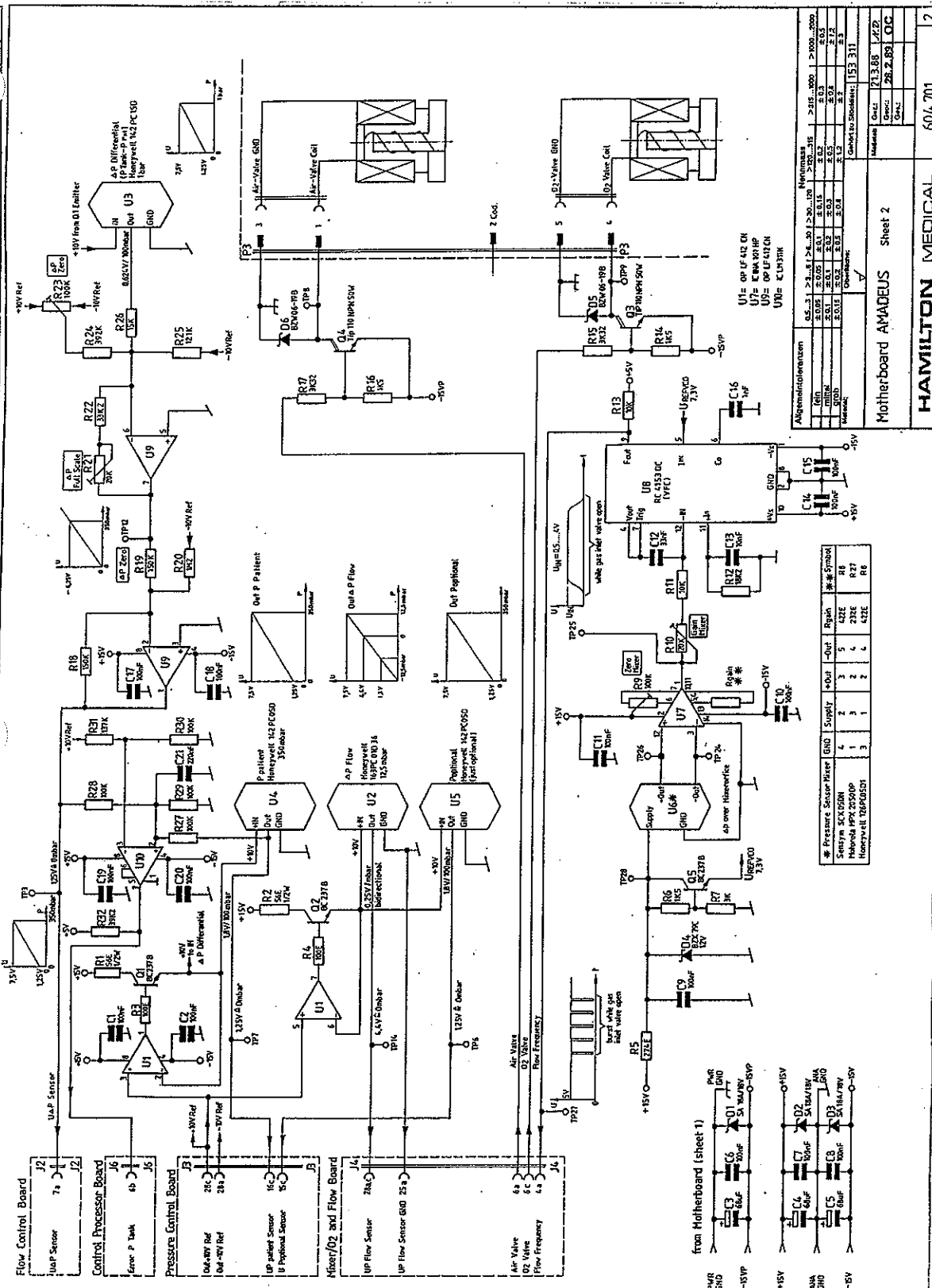
Service Manual AMADEUS

Sheet 1 of 1

SECTION 4 MOTHERBOARD

Used with part 3

Version 3



Part No.	Quantity	Part No.	Quantity
U1	1	U6	1
U2	1	U7	1
U3	1	U8	1
U4	1	U9	1
U5	1	U10	1

Part No.	Quantity	Part No.	Quantity
R1	1	R13	1
R2	1	R14	1
R3	1	R15	1
R4	1	R16	1
R5	1	R17	1

Part No.	Quantity	Part No.	Quantity
C1	1	C8	1
C2	1	C9	1
C3	1	C10	1
C4	1	C11	1
C5	1	C12	1

Part No.	Quantity	Part No.	Quantity
D1	1	D6	1
D2	1	D7	1
D3	1	D8	1
D4	1	D9	1
D5	1	D10	1

Alignment Information

Item	Min	Max	Units
U1	0.5	1.5	mm
U2	0.5	1.5	mm
U3	0.5	1.5	mm
U4	0.5	1.5	mm
U5	0.5	1.5	mm
U6	0.5	1.5	mm
U7	0.5	1.5	mm
U8	0.5	1.5	mm
U9	0.5	1.5	mm
U10	0.5	1.5	mm

Pressure Sensor Pinout

Pin	Supply	Out	Reg	Reg
1	+	+	4	5
2	-	-	3	4
3	+	+	2	3
4	-	-	1	2

Flow Frequency

Flow Frequency	Out	Reg
0.5	+	4
1.0	-	3
1.5	+	2
2.0	-	1

Flow Frequency

Flow Frequency	Out	Reg
0.5	+	4
1.0	-	3
1.5	+	2
2.0	-	1

Flow Frequency

Flow Frequency	Out	Reg
0.5	+	4
1.0	-	3
1.5	+	2
2.0	-	1

Flow Frequency

Flow Frequency	Out	Reg
0.5	+	4
1.0	-	3
1.5	+	2
2.0	-	1

Flow Frequency

Flow Frequency	Out	Reg
0.5	+	4
1.0	-	3
1.5	+	2
2.0	-	1

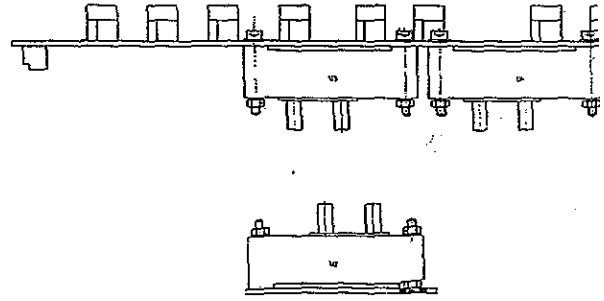
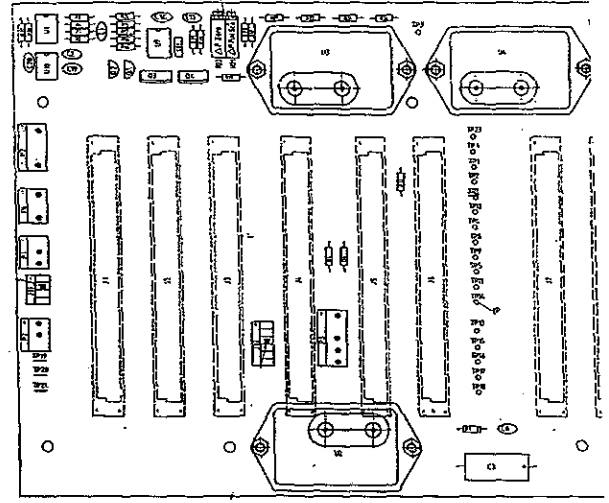
U1= OP UF 42 GN
 U2= KBA 3014P
 U3= OP UF 42 GN
 U4= OP UF 42 GN
 U5= OP UF 42 GN
 U6= K L V 31 K

from Motherboard (sheet 1)

R1, R2, R3, R4, R5, R6, R7, R8, R9, R10, R11, R12, R13, R14, R15, R16, R17, R18, R19, R20, R21, R22, R23, R24, R25, R26, R27, R28

C1, C2, C3, C4, C5, C6, C7, C8, C9, C10, C11, C12, C13, C14, C15

D1, D2, D3, D4, D5, D6, D7, D8, D9, D10



1:1

5	FRONT PANEL PROCESSING	5-2
	5.1 FRONT PANEL PROCESSING	5-2
	FRONT PANEL PROCESSER BOARD	5-3
	614059 Block Diagram	5-3
	604708 Schematic Diagram	5-4
	150320 Board Drawing	5-5
	CONTROL BOARD	5-6
	604705 Schematic Diagram	5-6
	153350 Board Drawing	5-7
	MONITOR BOARD	5-8
	604704/1 Schematic Diagram	5-8
	604704/2 Schematic Diagram	5-9
	153340 Board Drawing	5-10

5 FRONT PANEL PROCESSING



fig.5_1

5.1 FRONT PANEL PROCESSING

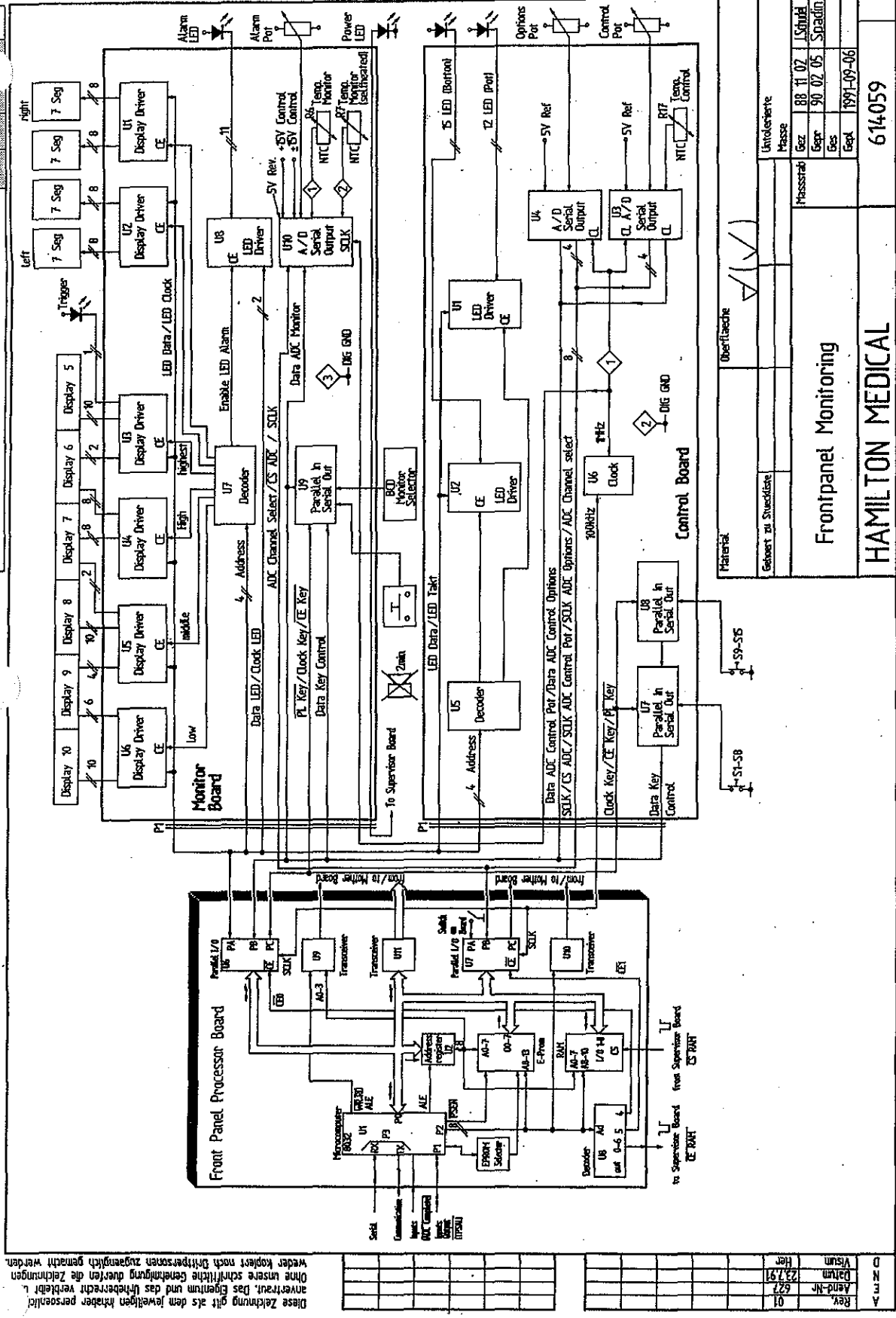
The Front Panel processing system is responsible for managing all the control and alarm information going to and coming from the Front Panel. In the **AMADEUS** the Front panel processing involves three boards: the Front panel Microprocessor Board, the Control Board and the Monitor Board.

The Front Panel Microprocessor Board contains an 8032 Intel microprocessor and the necessary electronics to manage all the information going to and coming from the Front Panel.

The Control and Monitor Boards are located on the front panel. The function of the Control Board is to send the control settings and the push key information to the microprocessor. The Monitor Board sends the alarm settings to the microprocessor and receives whatever information needs to be displayed from the Microprocessor. Both the control and Monitor Boards contain analog to digital convertors and the LEDs that are illuminated by the microprocessor when a push button or knob is activated.

SECTION 5 FRONT PANEL PROCESSING

Used with marked 30 31 32

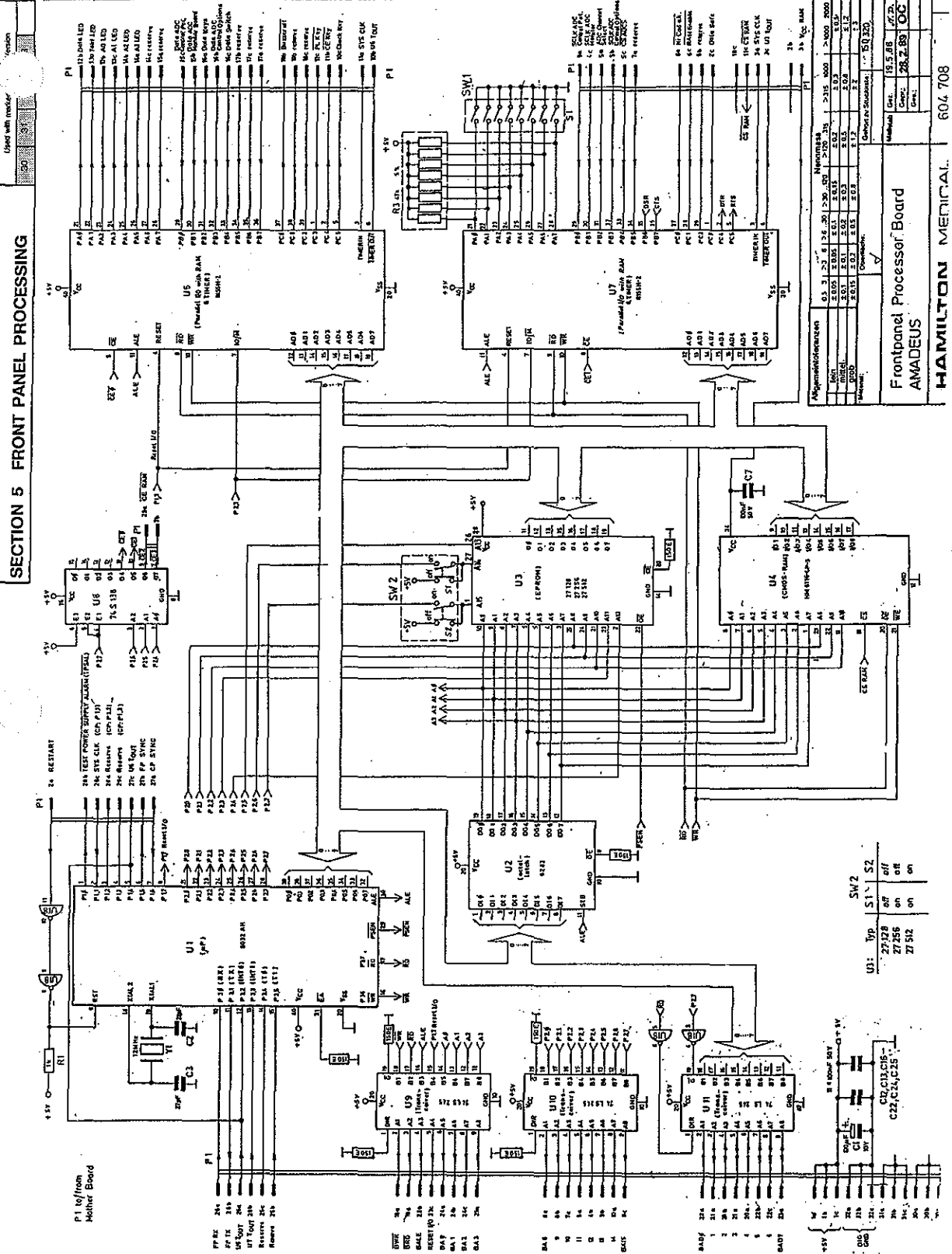


Diese Zeichnung gilt als dem jeweiligen Inhaber persönlich anvertraut. Das Eigentum und das Urheberrecht verbleibt bei uns. Ohne schriftliche Genehmigung dürfen die Zeichnungen weder kopiert noch Dritten zugänglich gemacht werden.

Rev.	Rev. No.	Date	By	Appr.
01	627	23/91	Hef	

Frontpanel Monitoring		HAMILTON MEDICAL	
Material		Überfläche	
Gehebt zu Stückliste		Involverte	
		Platte	
		Grz	88 11 02 L Schmid
		Exp	90 02 05 Spadin
		Les	
		Exp	1991-09-06
		614059	

SECTION 5 FRONT PANEL PROCESSING



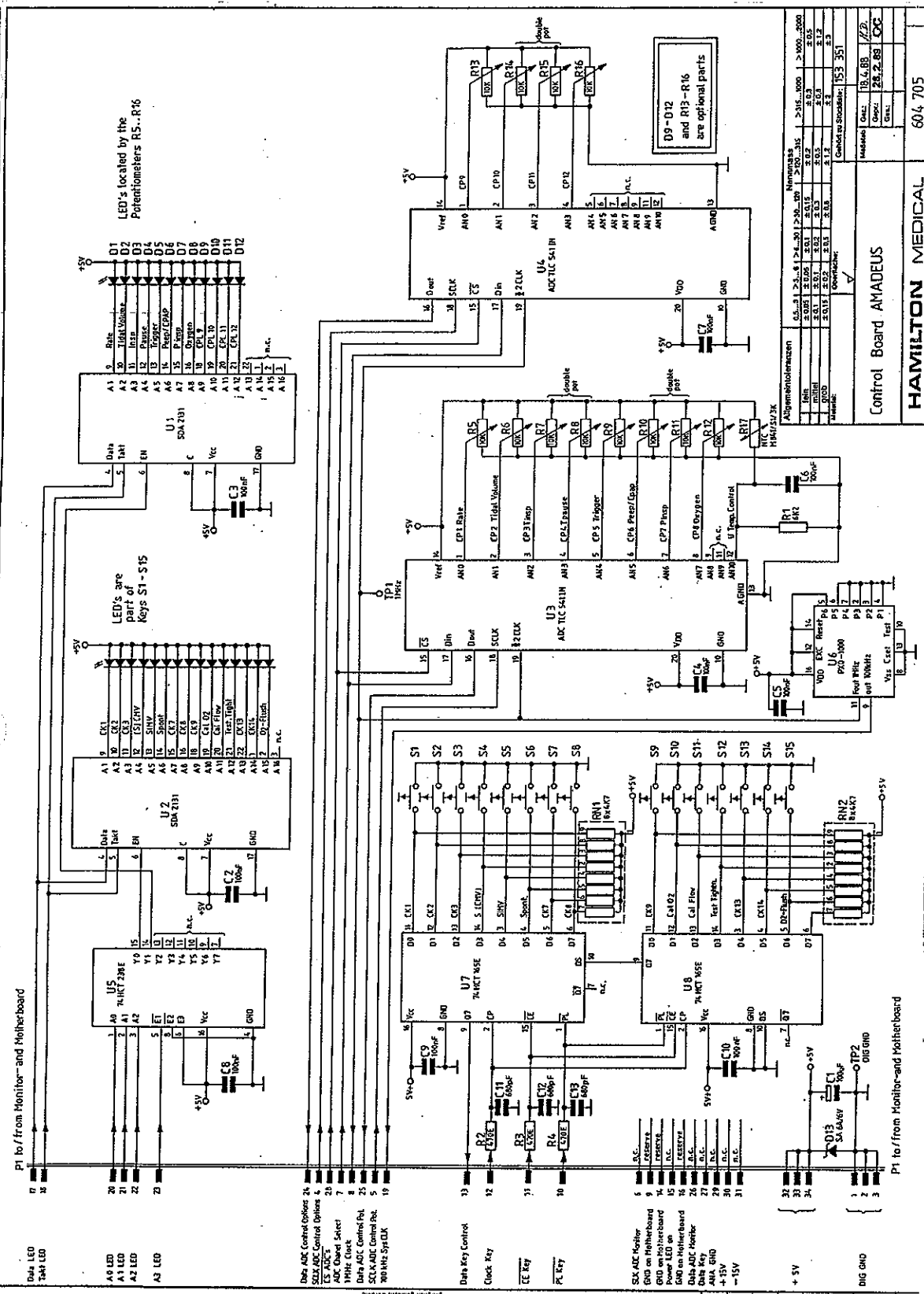
Magnetisierkennzeichen		Magnetisierkennzeichen	
01	02	03	04
01	02	03	04
05	06	07	08
09	10	11	12
13	14	15	16
17	18	19	20
21	22	23	24
25	26	27	28
29	30	31	32
33	34	35	36
37	38	39	40
41	42	43	44
45	46	47	48
49	50	51	52
53	54	55	56
57	58	59	60
61	62	63	64
65	66	67	68
69	70	71	72
73	74	75	76
77	78	79	80
81	82	83	84
85	86	87	88
89	90	91	92
93	94	95	96
97	98	99	100

Frontpanel Processor Board
AMADEUS
HAMILTON MEDICAL
 604 708

SECTION 5 FRONT PANEL PROCESSING

Used with marker

Version



Pin	Signal	Description
1	DATA LED	DATA LED
2	DATA LED	DATA LED
3	DATA LED	DATA LED
4	DATA LED	DATA LED
5	DATA LED	DATA LED
6	DATA LED	DATA LED
7	DATA LED	DATA LED
8	DATA LED	DATA LED
9	DATA LED	DATA LED
10	DATA LED	DATA LED
11	DATA LED	DATA LED
12	DATA LED	DATA LED
13	DATA LED	DATA LED
14	DATA LED	DATA LED
15	DATA LED	DATA LED
16	DATA LED	DATA LED
17	DATA LED	DATA LED
18	DATA LED	DATA LED
19	DATA LED	DATA LED
20	DATA LED	DATA LED
21	DATA LED	DATA LED
22	DATA LED	DATA LED
23	DATA LED	DATA LED
24	DATA LED	DATA LED
25	DATA LED	DATA LED
26	DATA LED	DATA LED
27	DATA LED	DATA LED
28	DATA LED	DATA LED
29	DATA LED	DATA LED
30	DATA LED	DATA LED
31	DATA LED	DATA LED
32	DATA LED	DATA LED
33	DATA LED	DATA LED
34	DATA LED	DATA LED
35	DATA LED	DATA LED
36	DATA LED	DATA LED
37	DATA LED	DATA LED
38	DATA LED	DATA LED
39	DATA LED	DATA LED
40	DATA LED	DATA LED
41	DATA LED	DATA LED
42	DATA LED	DATA LED
43	DATA LED	DATA LED
44	DATA LED	DATA LED
45	DATA LED	DATA LED
46	DATA LED	DATA LED
47	DATA LED	DATA LED
48	DATA LED	DATA LED
49	DATA LED	DATA LED
50	DATA LED	DATA LED
51	DATA LED	DATA LED
52	DATA LED	DATA LED
53	DATA LED	DATA LED
54	DATA LED	DATA LED
55	DATA LED	DATA LED
56	DATA LED	DATA LED
57	DATA LED	DATA LED
58	DATA LED	DATA LED
59	DATA LED	DATA LED
60	DATA LED	DATA LED
61	DATA LED	DATA LED
62	DATA LED	DATA LED
63	DATA LED	DATA LED
64	DATA LED	DATA LED
65	DATA LED	DATA LED
66	DATA LED	DATA LED
67	DATA LED	DATA LED
68	DATA LED	DATA LED
69	DATA LED	DATA LED
70	DATA LED	DATA LED
71	DATA LED	DATA LED
72	DATA LED	DATA LED
73	DATA LED	DATA LED
74	DATA LED	DATA LED
75	DATA LED	DATA LED
76	DATA LED	DATA LED
77	DATA LED	DATA LED
78	DATA LED	DATA LED
79	DATA LED	DATA LED
80	DATA LED	DATA LED
81	DATA LED	DATA LED
82	DATA LED	DATA LED
83	DATA LED	DATA LED
84	DATA LED	DATA LED
85	DATA LED	DATA LED
86	DATA LED	DATA LED
87	DATA LED	DATA LED
88	DATA LED	DATA LED
89	DATA LED	DATA LED
90	DATA LED	DATA LED
91	DATA LED	DATA LED
92	DATA LED	DATA LED
93	DATA LED	DATA LED
94	DATA LED	DATA LED
95	DATA LED	DATA LED
96	DATA LED	DATA LED
97	DATA LED	DATA LED
98	DATA LED	DATA LED
99	DATA LED	DATA LED
100	DATA LED	DATA LED

Part No.	Quantity	Description	Notes
U1	1	SDA 2131	
U2	1	SDA 2131	
U3	1	ADC TICS 5418	
U4	1	74NCT 5418	
U5	1	74NCT 238E	
U6	1	5V Regulator	
U7	1	15V Regulator	
U8	1	74NCT 5418	
R1	1	1K2	
R2	1	100K	
R3	1	100K	
R4	1	100K	
R5	1	100K	
R6	1	100K	
R7	1	100K	
R8	1	100K	
R9	1	100K	
R10	1	100K	
R11	1	100K	
R12	1	100K	
R13	1	100K	
R14	1	100K	
R15	1	100K	
R16	1	100K	
C1	1	100K	
C2	1	100K	
C3	1	100K	
C4	1	100K	
C5	1	100K	
C6	1	100K	
C7	1	100K	
J1	1	100K	
J2	1	100K	
J3	1	100K	
J4	1	100K	
J5	1	100K	
J6	1	100K	
J7	1	100K	
J8	1	100K	
J9	1	100K	
J10	1	100K	
J11	1	100K	
J12	1	100K	
J13	1	100K	
J14	1	100K	
J15	1	100K	
J16	1	100K	
J17	1	100K	
J18	1	100K	
J19	1	100K	
J20	1	100K	
J21	1	100K	
J22	1	100K	
J23	1	100K	
J24	1	100K	
J25	1	100K	
J26	1	100K	
J27	1	100K	
J28	1	100K	
J29	1	100K	
J30	1	100K	
J31	1	100K	
J32	1	100K	
J33	1	100K	
J34	1	100K	
J35	1	100K	
J36	1	100K	
J37	1	100K	
J38	1	100K	
J39	1	100K	
J40	1	100K	
J41	1	100K	
J42	1	100K	
J43	1	100K	
J44	1	100K	
J45	1	100K	
J46	1	100K	
J47	1	100K	
J48	1	100K	
J49	1	100K	
J50	1	100K	
J51	1	100K	
J52	1	100K	
J53	1	100K	
J54	1	100K	
J55	1	100K	
J56	1	100K	
J57	1	100K	
J58	1	100K	
J59	1	100K	
J60	1	100K	
J61	1	100K	
J62	1	100K	
J63	1	100K	
J64	1	100K	
J65	1	100K	
J66	1	100K	
J67	1	100K	
J68	1	100K	
J69	1	100K	
J70	1	100K	
J71	1	100K	
J72	1	100K	
J73	1	100K	
J74	1	100K	
J75	1	100K	
J76	1	100K	
J77	1	100K	
J78	1	100K	
J79	1	100K	
J80	1	100K	
J81	1	100K	
J82	1	100K	
J83	1	100K	
J84	1	100K	
J85	1	100K	
J86	1	100K	
J87	1	100K	
J88	1	100K	
J89	1	100K	
J90	1	100K	
J91	1	100K	
J92	1	100K	
J93	1	100K	
J94	1	100K	
J95	1	100K	
J96	1	100K	
J97	1	100K	
J98	1	100K	
J99	1	100K	
J100	1	100K	

Part No.	Quantity	Description	Notes
U9-D12	1	Potentiometers	Optional parts
R13	1	100K	Optional part
R14	1	100K	Optional part
R15	1	100K	Optional part
R16	1	100K	Optional part

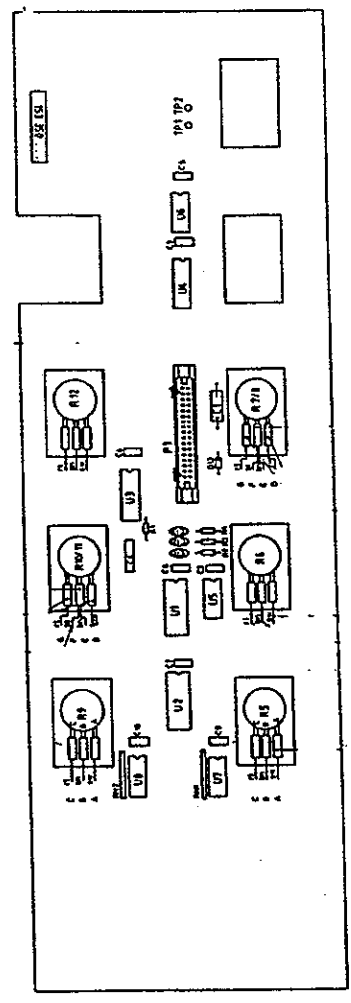
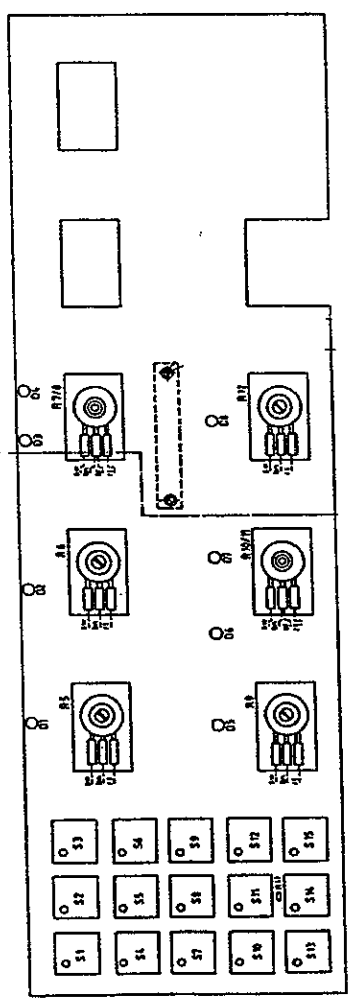
Part No.	Quantity	Description	Notes
U9-D12	1	Potentiometers	Optional parts
R13	1	100K	Optional part
R14	1	100K	Optional part
R15	1	100K	Optional part
R16	1	100K	Optional part

SECTION 5 FRONT PANEL PROCESSING

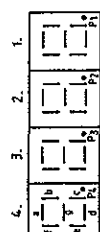
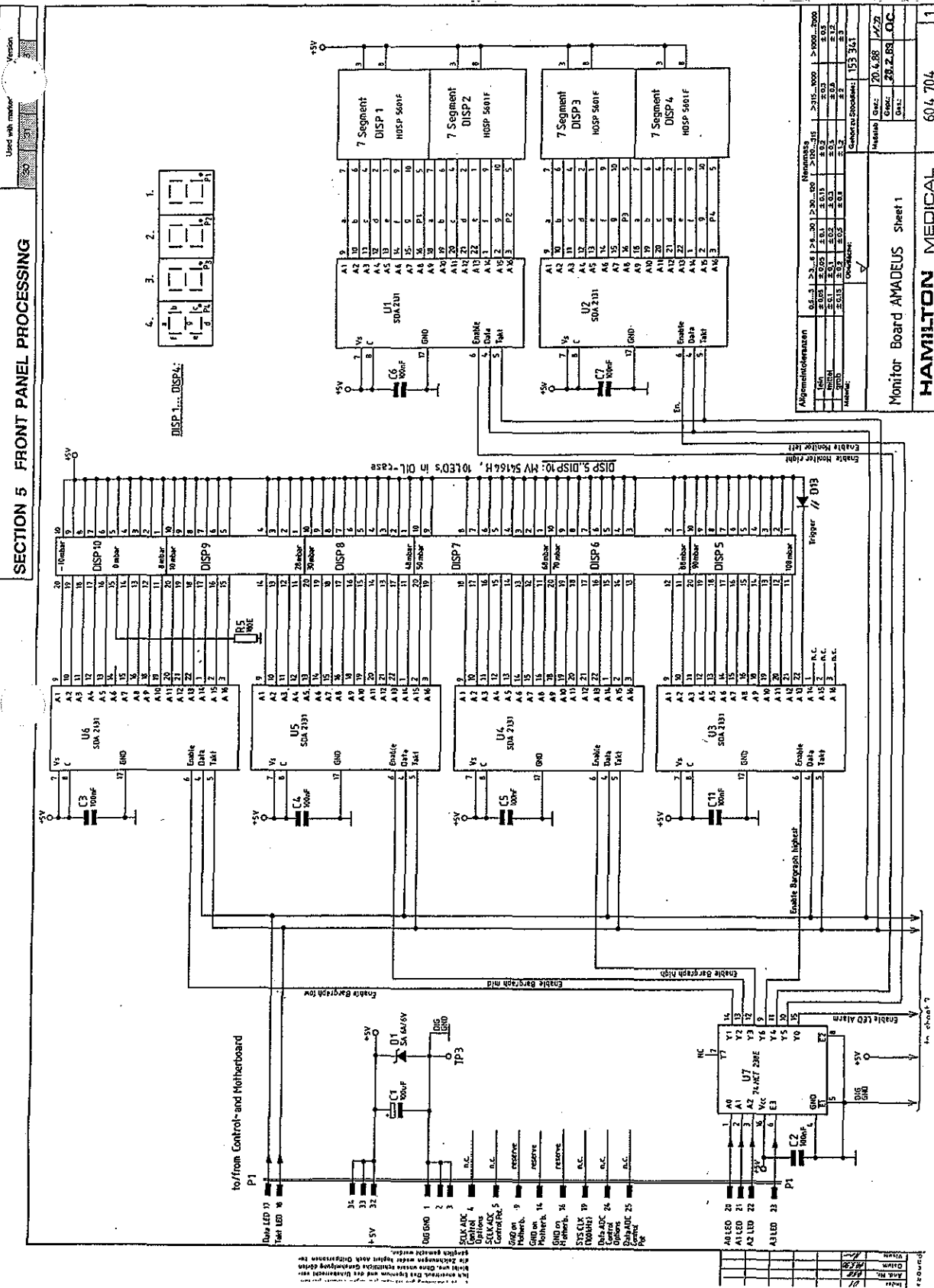
Used with marked Software Version

30	31	32	33
----	----	----	----

Part No.	153 350
Rev.	1
Quantity	1
Material	153 350
Manufacturer	HAMILTON MEDICAL
Control Board	
Part No.	153 350
Rev.	1
Quantity	1
Material	153 350
Manufacturer	HAMILTON MEDICAL



SECTION 5 FRONT PANEL PROCESSING



Abgleichdaten		Messwerte	
0.0...1.0	1.2...1.8	1.2...1.8	1.2...1.8
1.0...2.0	2.0...3.0	2.0...3.0	2.0...3.0
2.0...3.0	3.0...4.0	3.0...4.0	3.0...4.0
3.0...4.0	4.0...5.0	4.0...5.0	4.0...5.0
4.0...5.0	5.0...6.0	5.0...6.0	5.0...6.0
5.0...6.0	6.0...7.0	6.0...7.0	6.0...7.0
6.0...7.0	7.0...8.0	7.0...8.0	7.0...8.0
7.0...8.0	8.0...9.0	8.0...9.0	8.0...9.0
8.0...9.0	9.0...10.0	9.0...10.0	9.0...10.0
9.0...10.0	10.0...11.0	10.0...11.0	10.0...11.0
10.0...11.0	11.0...12.0	11.0...12.0	11.0...12.0
11.0...12.0	12.0...13.0	12.0...13.0	12.0...13.0
12.0...13.0	13.0...14.0	13.0...14.0	13.0...14.0
13.0...14.0	14.0...15.0	14.0...15.0	14.0...15.0
14.0...15.0	15.0...16.0	15.0...16.0	15.0...16.0
15.0...16.0	16.0...17.0	16.0...17.0	16.0...17.0
16.0...17.0	17.0...18.0	17.0...18.0	17.0...18.0
17.0...18.0	18.0...19.0	18.0...19.0	18.0...19.0
18.0...19.0	19.0...20.0	19.0...20.0	19.0...20.0
19.0...20.0	20.0...21.0	20.0...21.0	20.0...21.0
20.0...21.0	21.0...22.0	21.0...22.0	21.0...22.0
21.0...22.0	22.0...23.0	22.0...23.0	22.0...23.0
22.0...23.0	23.0...24.0	23.0...24.0	23.0...24.0
23.0...24.0	24.0...25.0	24.0...25.0	24.0...25.0
24.0...25.0	25.0...26.0	25.0...26.0	25.0...26.0
25.0...26.0	26.0...27.0	26.0...27.0	26.0...27.0
26.0...27.0	27.0...28.0	27.0...28.0	27.0...28.0
27.0...28.0	28.0...29.0	28.0...29.0	28.0...29.0
28.0...29.0	29.0...30.0	29.0...30.0	29.0...30.0
29.0...30.0	30.0...31.0	30.0...31.0	30.0...31.0
30.0...31.0	31.0...32.0	31.0...32.0	31.0...32.0
31.0...32.0	32.0...33.0	32.0...33.0	32.0...33.0
32.0...33.0	33.0...34.0	33.0...34.0	33.0...34.0
33.0...34.0	34.0...35.0	34.0...35.0	34.0...35.0
34.0...35.0	35.0...36.0	35.0...36.0	35.0...36.0
35.0...36.0	36.0...37.0	36.0...37.0	36.0...37.0
36.0...37.0	37.0...38.0	37.0...38.0	37.0...38.0
37.0...38.0	38.0...39.0	38.0...39.0	38.0...39.0
38.0...39.0	39.0...40.0	39.0...40.0	39.0...40.0
39.0...40.0	40.0...41.0	40.0...41.0	40.0...41.0
40.0...41.0	41.0...42.0	41.0...42.0	41.0...42.0
41.0...42.0	42.0...43.0	42.0...43.0	42.0...43.0
42.0...43.0	43.0...44.0	43.0...44.0	43.0...44.0
43.0...44.0	44.0...45.0	44.0...45.0	44.0...45.0
44.0...45.0	45.0...46.0	45.0...46.0	45.0...46.0
45.0...46.0	46.0...47.0	46.0...47.0	46.0...47.0
46.0...47.0	47.0...48.0	47.0...48.0	47.0...48.0
47.0...48.0	48.0...49.0	48.0...49.0	48.0...49.0
48.0...49.0	49.0...50.0	49.0...50.0	49.0...50.0
49.0...50.0	50.0...51.0	50.0...51.0	50.0...51.0
50.0...51.0	51.0...52.0	51.0...52.0	51.0...52.0
51.0...52.0	52.0...53.0	52.0...53.0	52.0...53.0
52.0...53.0	53.0...54.0	53.0...54.0	53.0...54.0
53.0...54.0	54.0...55.0	54.0...55.0	54.0...55.0
54.0...55.0	55.0...56.0	55.0...56.0	55.0...56.0
55.0...56.0	56.0...57.0	56.0...57.0	56.0...57.0
56.0...57.0	57.0...58.0	57.0...58.0	57.0...58.0
57.0...58.0	58.0...59.0	58.0...59.0	58.0...59.0
58.0...59.0	59.0...60.0	59.0...60.0	59.0...60.0
59.0...60.0	60.0...61.0	60.0...61.0	60.0...61.0
60.0...61.0	61.0...62.0	61.0...62.0	61.0...62.0
61.0...62.0	62.0...63.0	62.0...63.0	62.0...63.0
62.0...63.0	63.0...64.0	63.0...64.0	63.0...64.0
63.0...64.0	64.0...65.0	64.0...65.0	64.0...65.0
64.0...65.0	65.0...66.0	65.0...66.0	65.0...66.0
65.0...66.0	66.0...67.0	66.0...67.0	66.0...67.0
66.0...67.0	67.0...68.0	67.0...68.0	67.0...68.0
67.0...68.0	68.0...69.0	68.0...69.0	68.0...69.0
68.0...69.0	69.0...70.0	69.0...70.0	69.0...70.0
69.0...70.0	70.0...71.0	70.0...71.0	70.0...71.0
70.0...71.0	71.0...72.0	71.0...72.0	71.0...72.0
71.0...72.0	72.0...73.0	72.0...73.0	72.0...73.0
72.0...73.0	73.0...74.0	73.0...74.0	73.0...74.0
73.0...74.0	74.0...75.0	74.0...75.0	74.0...75.0
74.0...75.0	75.0...76.0	75.0...76.0	75.0...76.0
75.0...76.0	76.0...77.0	76.0...77.0	76.0...77.0
76.0...77.0	77.0...78.0	77.0...78.0	77.0...78.0
77.0...78.0	78.0...79.0	78.0...79.0	78.0...79.0
78.0...79.0	79.0...80.0	79.0...80.0	79.0...80.0
79.0...80.0	80.0...81.0	80.0...81.0	80.0...81.0
80.0...81.0	81.0...82.0	81.0...82.0	81.0...82.0
81.0...82.0	82.0...83.0	82.0...83.0	82.0...83.0
82.0...83.0	83.0...84.0	83.0...84.0	83.0...84.0
83.0...84.0	84.0...85.0	84.0...85.0	84.0...85.0
84.0...85.0	85.0...86.0	85.0...86.0	85.0...86.0
85.0...86.0	86.0...87.0	86.0...87.0	86.0...87.0
86.0...87.0	87.0...88.0	87.0...88.0	87.0...88.0
87.0...88.0	88.0...89.0	88.0...89.0	88.0...89.0
88.0...89.0	89.0...90.0	89.0...90.0	89.0...90.0
89.0...90.0	90.0...91.0	90.0...91.0	90.0...91.0
90.0...91.0	91.0...92.0	91.0...92.0	91.0...92.0
91.0...92.0	92.0...93.0	92.0...93.0	92.0...93.0
92.0...93.0	93.0...94.0	93.0...94.0	93.0...94.0
93.0...94.0	94.0...95.0	94.0...95.0	94.0...95.0
94.0...95.0	95.0...96.0	95.0...96.0	95.0...96.0
95.0...96.0	96.0...97.0	96.0...97.0	96.0...97.0
96.0...97.0	97.0...98.0	97.0...98.0	97.0...98.0
97.0...98.0	98.0...99.0	98.0...99.0	98.0...99.0
98.0...99.0	99.0...100.0	99.0...100.0	99.0...100.0

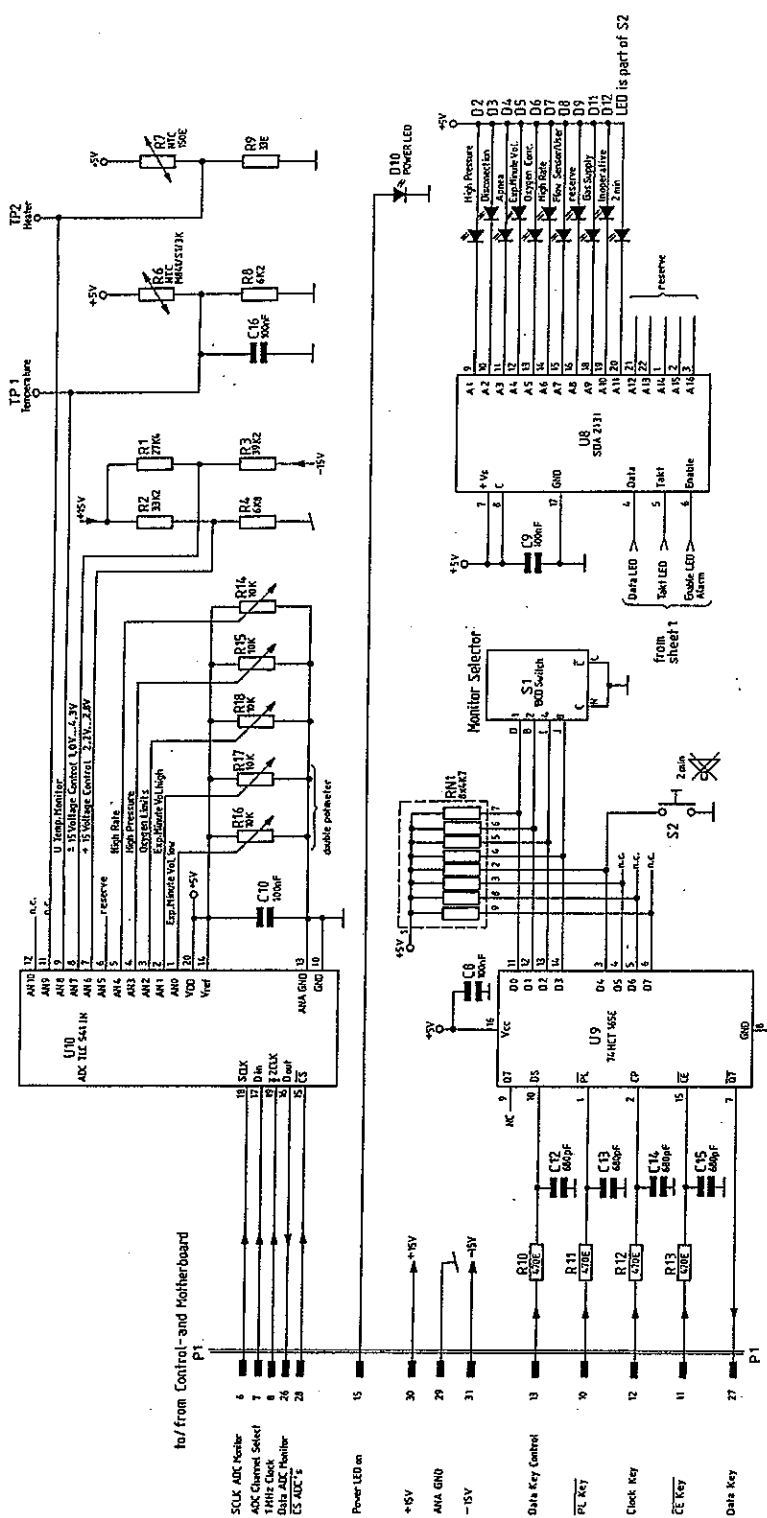
Monitor Board AMADEUS Sheet 1
HAMILTON MEDICAL
 604 704

22.2.1994 8:26am
 HAMILTON MEDICAL AG
 Services Manual AMADEUS
 Order-No. 610 221

1

SECTION 5 FRONT PANEL PROCESSING

Used with motor: 30 31



MONITOR SELECTOR (S1 BCD Switch)

DS	DZ	D1	D0	pec	Monitor/Display
0	0	0	0	0	Flash/No Flash test
0	0	0	1	0	Normal
0	0	0	1	1	High Rate
0	0	1	0	0	Exp. Rate
0	0	1	0	1	Exp. Rate Vol.
0	1	0	0	0	Exp. Rate Vol.
0	1	0	0	1	Exp. Rate Vol.
0	1	1	0	0	Flash/Temp test
0	1	1	0	1	Flash/Temp test

optional parameters see service manual

Allgemein/Eigenschaften		Normenansatz	>215...216	>216...218	>218...219	>219...220
Teil	22.2.1.1	1.1	1.2	1.3	1.4	1.5
Druck	22.2.1.1	22.2.1.1	22.2.1.1	22.2.1.1	22.2.1.1	22.2.1.1
Material	22.2.1.1	22.2.1.1	22.2.1.1	22.2.1.1	22.2.1.1	22.2.1.1
Drucknummer: 153 344		Material: 153 344	Größe: 153 344	Größe: 153 344	Größe: 153 344	Größe: 153 344
Monitor Board AMADEUS Sheet 2		Größe: 153 344	Größe: 153 344	Größe: 153 344	Größe: 153 344	Größe: 153 344
HAMILTON MEDICAL		Größe: 153 344	Größe: 153 344	Größe: 153 344	Größe: 153 344	Größe: 153 344
604 704		Größe: 153 344	Größe: 153 344	Größe: 153 344	Größe: 153 344	Größe: 153 344

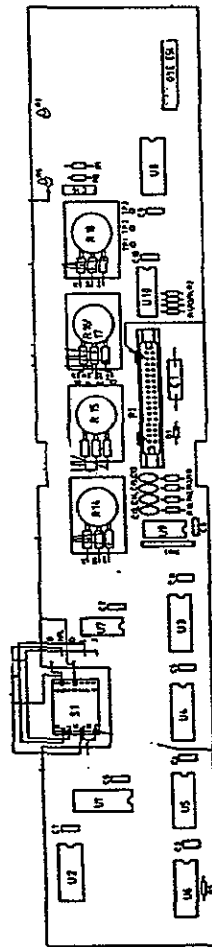
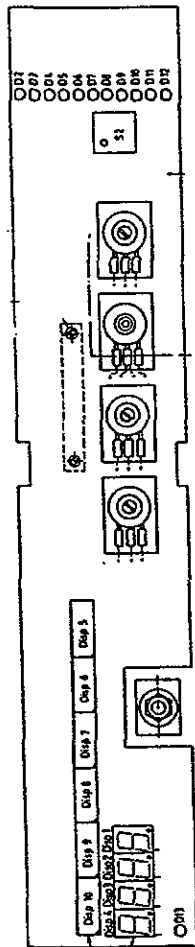
22.2.1994 8.2568
HAMILTON MEDICAL AG
Service Manual AMADEUS Order-No. 610 221

SECTION 5 FRONT PANEL PROCESSING

Used with marked Software Version

30	31	32	33
----	----	----	----

Part No.	153 340
Rev.	1.1
Manufacturer	HAMILTON MEDICAL
Product Name	Monitor Board
Part No.	153 340
Rev.	1.1
Manufacturer	HAMILTON MEDICAL
Product Name	Monitor Board



6	CONTROL PROCESSING	6-2
6.1	DESCRIPTION OF THE CONTROL PROCESSING ..	6-2
	CONTROL PROCESSOR BOARD	6-3
	614058 Block Schematic	6-3
	604707 Schematic Diagram	6-4
	150320 Board Drawing	6-5
	ANALOG I/O BOARD	6-6
	604709 Schematic diagram	6-6
	150400 Board Drawing	6-7

6 CONTROL PROCESSING

6.1 DESCRIPTION OF THE CONTROL PROCESSING

The Control Processing system of the AMADEUS is made up of two boards: the Control Processor Board and the analog I/O Board.

The Control Processor Board is identical to the Front Panel Processor Board, but its EPROMs contain different software. The microprocessor on the Control Processor board manages all incoming information and generates the signals responsible for controlling the ventilator. Some of the functions of the control microprocessor are to calculate the values to be

displayed on the front panel. (Note: check to see if the other two microprocessors are functioning correctly and controlling the analog valves of the ventilator). The function of the Analog I/O Board in this system is to provide a communication link between the microprocessor and all the analog signals (parts). The Analog I/O Board contains a 12 bit analog to digital converter that handles the 8 analog signals coming from the ventilator. Also located on the Analog I/O Board are two digital to analog converters (DAC), with which the microprocessor controls the Servo and Expiratory valves. The Expiratory Valve sends controlling voltages through the 8 bit DAC, but the Servo Valve which requires more precision, uses a 12 bit DAC.

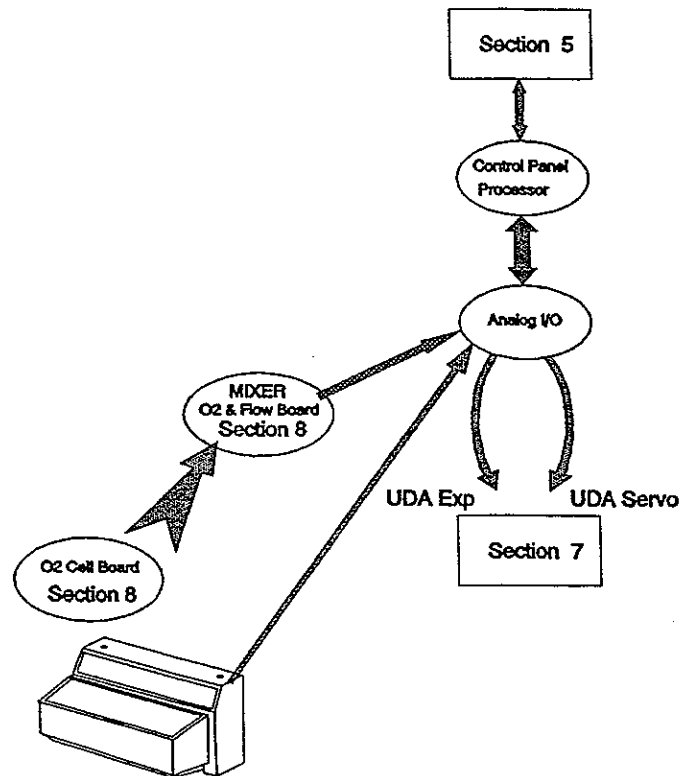
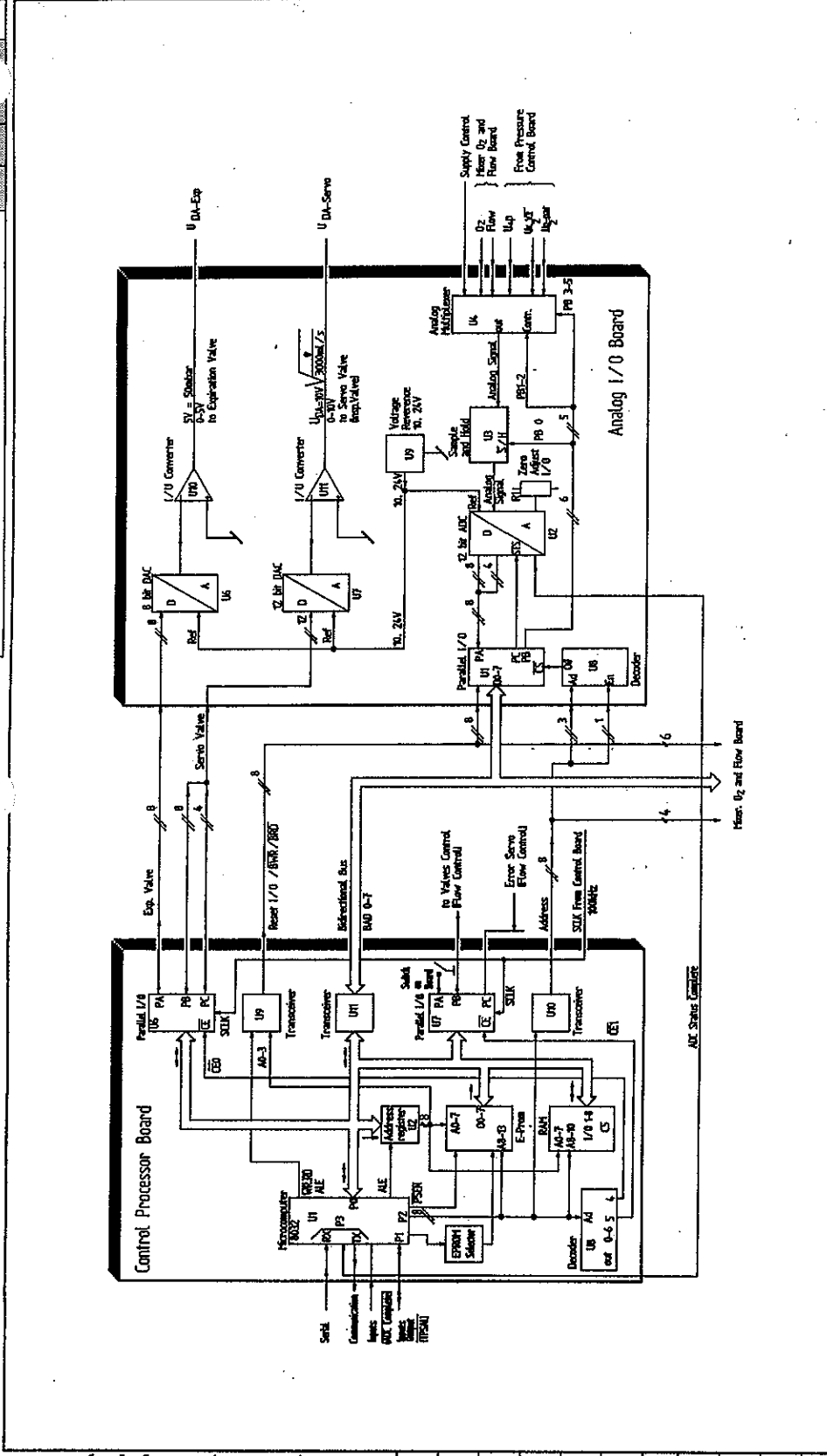


Figure 6_1



SECTION 6 CONTROL PROCESSING

Usecd with marker



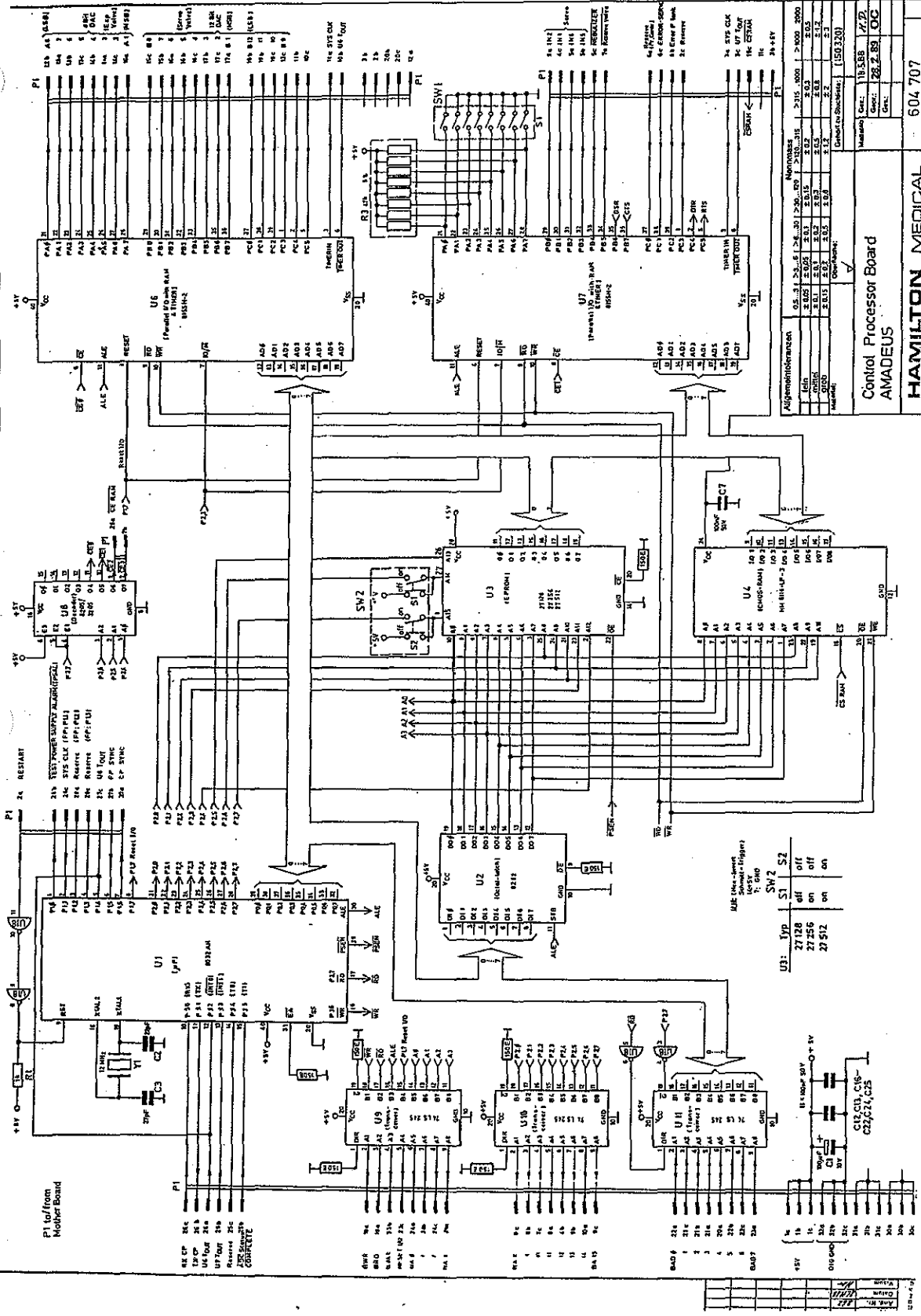
Diese Zeichnung gilt als dem jeweiligen Inhaber persönlich anvertraut. Das Eigentum und das Urheberrecht verbleibt uns. Ohne unsere schriftliche Genehmigung dürfen die Zeichnungen weder kopiert noch Dritten zugängig gemacht werden.

Material	Überfläche	U/V
Gehört zu Stückliste		
Control Processing AMADEUS		
HAMILTON MEDICAL		
Rev.	01	
Änd.-Nr.	627	
Visum	22/91	
Datum		
Massstab	Gez 90 11 19	U.F.
	Gez 90 11 19	J.M.
	Des	
	Dept	1991-09-06
614058		

22.2.1994 8:46am
 HAMILTON MEDICAL AG
 Service Manual AMADEUS
 Order-No. 610 221
 6-3

SECTION 6 CONTROL PROCESSING

Used with manual



Alignment/Parameter	0.5	1	2	3	4	5	6	7	8	9	10	11	12	13	14	15	16	17	18	19	20	21	22	23	24	25	26	27	28	29	30	31	32	33	34	35	36	37	38	39	40	41	42	43	44	45	46	47	48	49	50	51	52	53	54	55	56	57	58	59	60	61	62	63	64	65	66	67	68	69	70	71	72	73	74	75	76	77	78	79	80	81	82	83	84	85	86	87	88	89	90	91	92	93	94	95	96	97	98	99	100
Gain	0.01	0.02	0.03	0.04	0.05	0.06	0.07	0.08	0.09	0.10	0.11	0.12	0.13	0.14	0.15	0.16	0.17	0.18	0.19	0.20	0.21	0.22	0.23	0.24	0.25	0.26	0.27	0.28	0.29	0.30	0.31	0.32	0.33	0.34	0.35	0.36	0.37	0.38	0.39	0.40	0.41	0.42	0.43	0.44	0.45	0.46	0.47	0.48	0.49	0.50	0.51	0.52	0.53	0.54	0.55	0.56	0.57	0.58	0.59	0.60	0.61	0.62	0.63	0.64	0.65	0.66	0.67	0.68	0.69	0.70	0.71	0.72	0.73	0.74	0.75	0.76	0.77	0.78	0.79	0.80	0.81	0.82	0.83	0.84	0.85	0.86	0.87	0.88	0.89	0.90	0.91	0.92	0.93	0.94	0.95	0.96	0.97	0.98	0.99	1.00	

Control Processor Board
AMADEUS

HAMILTON MEDICAL 604 707

SECTION 7 VALVE CONTROL

Used with marked Software Version

30	31	32	33
----	----	----	----

7	VALVE CONTROL	7-2
7.1	DESCRIPTION OF THE REGULATION LOOPS	7-2
7.1.1	Flow Regulation	7-2
7.1.2	Pressure Regulation	7-3
	SCHEMATICS OF THE FLOW AND PRESSURE CONTROL	
	LOOP	7-4
614066	Flow Control Loop	7-4
614065	Pressure Control Loop	7-5
7.2	SERVO VALVE	7-6
7.3	EXPIRATORY VALVE	7-6
	SCHEMATICS OF THE VALVES CONTROL	7-7
614057	Block Schematic	7-7
604714	Schematic Diagram	7-8
	FLOW CONTROL BAORD	7-9
150410	Board Drawing	7-9
	PRESSURE CONTROL BOARD	7-10
150425	Board drawing	7-10
	SERVO POWER BOARD	7-11
150430	Board Drawing	7-11
	SCHEMATICS OF THE VALVES CONTROL (30,31, 32)	7-12
604706	Schematic Diagram	7-12
	PRESSURE CONTROL BOARD	7-13
150420	Board drawing	7-13

7 VALVE CONTROL

7.1 DESCRIPTION OF THE REGULATION LOOPS

7.1.1 Flow Regulation

(see Drawing 614 066 - Flow Control Loop)

The Flow Regulation is used for Flow Controlled Ventilation (mandatory).

The control processor sends a signal (U_{DA} Servo), which is the desired square root of flow, to the comparison block. The compared and readjusted square root of flow runs through the Flow Regulator and is amplified on the Servo Power Board before driving the electrodynamic motor of the Servo.

The actual height of the plunger (using the potentiometer) and the pressure drop across the plunger (pressure sensors) are needed to calculate the feedback signal. This is compared with the desired square root of flow (from control processor) at the comparison block and closes the loop to a Flow Regulation.

Note: If the difference of ("square root of flow desired" - "square root of flow measured") is greater than 1V for longer than 5 seconds a Technical Fault 2 will occur. This can only be cleared by switching the ventilator off and on again. (For more information see Section 2, ALARM SYSTEM)

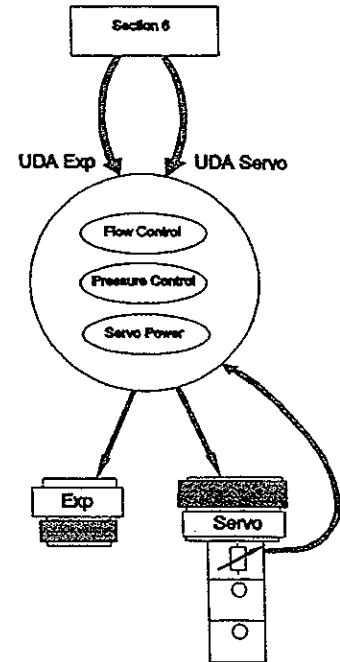


Figure 7_1

SECTION 7 VALVE CONTROL

Used with marked Software Version

30	31	32	33	
----	----	----	----	--

7.1.2 Pressure Regulation

(see Drawing 614 065 - Pressure Control Loop)

The pressure regulation loop is only used in spontaneous and pressure controlled breathing where the patient controls the amount of flow.

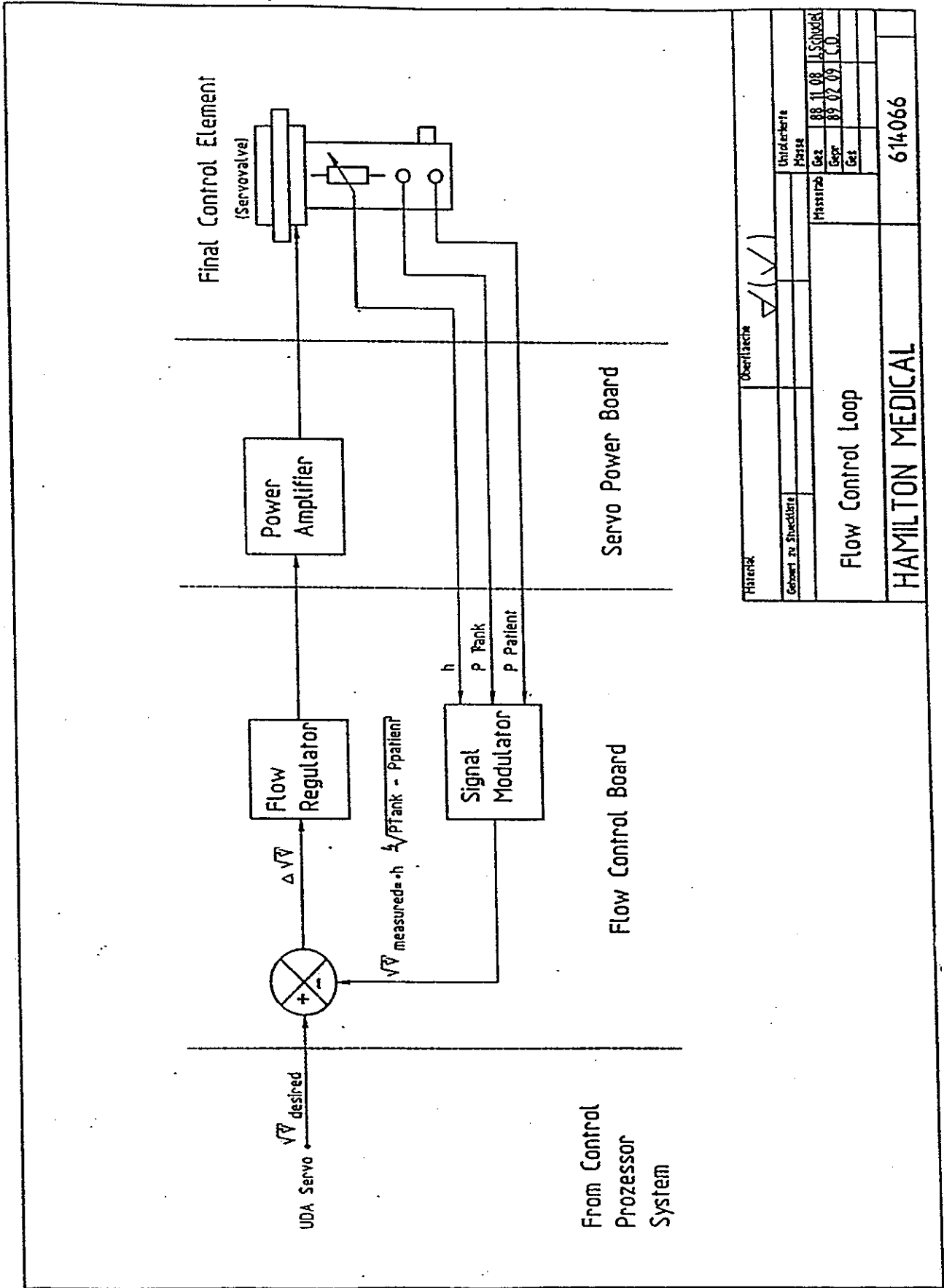
The control processor sends a signal (U_{DA} Servo), which is the P_{supp} , to the comparison block on the Pressure Control Board. The compared and readjusted P_{supp} runs through the Pressure/Flow Transducer and gets to the comparison block of the Flow Regulation.

To close the Pressure Regulation loop the pressure $P_{Patient}$ measured at the Servo is sent back and compared with the P_{supp} .

SECTION 7 VALVE CONTROL

Used with marked Software Version

30	31	32	33
----	----	----	----

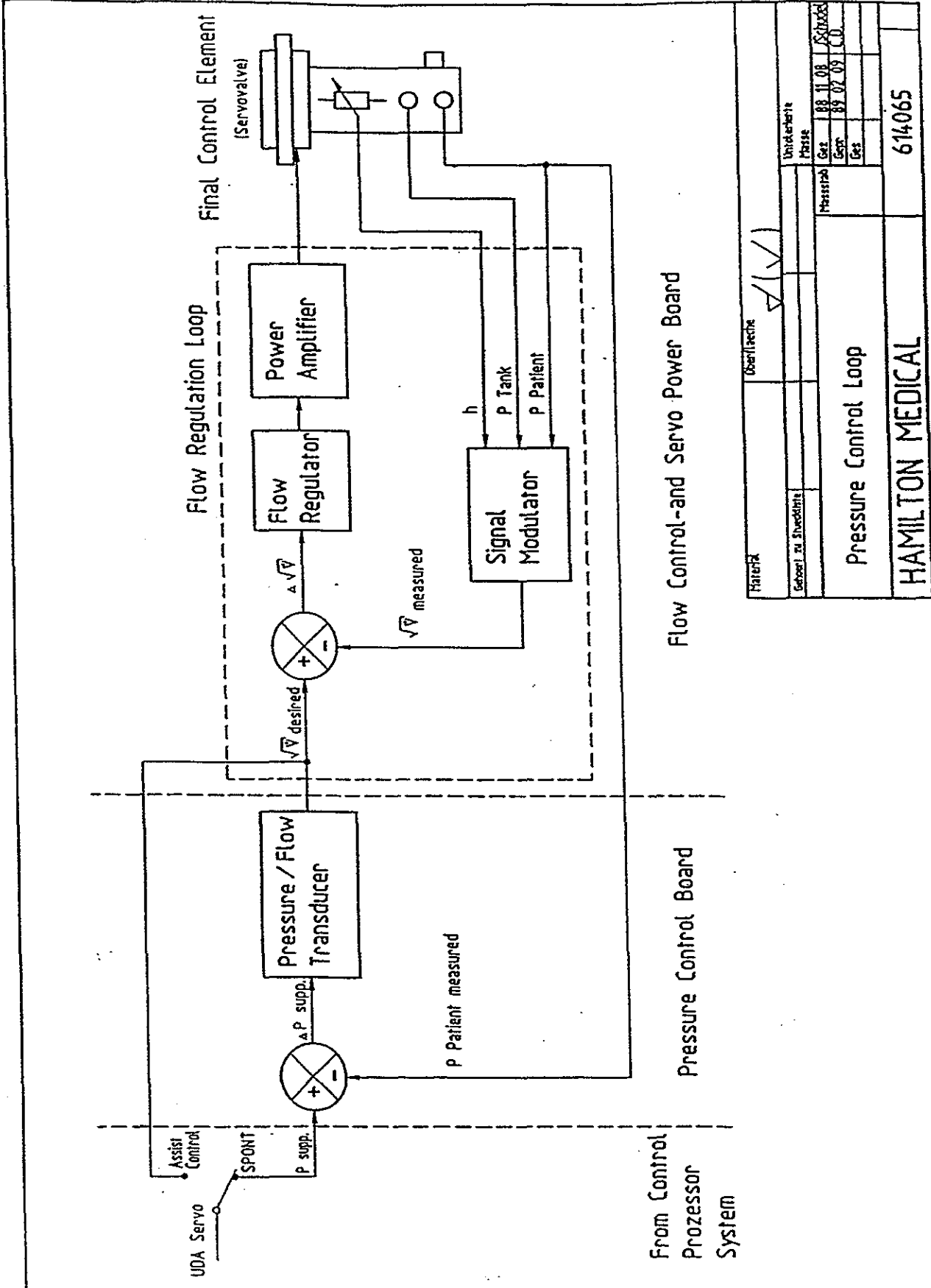


Historik		Oberfläche	
Gebaut zu	Struktur	Unvollständige	
		Phase	
		Massstab	1:88.11.08
		Gez.	A. Schödel
		Gez.	89.02.09
		Gez.	L.O.
Flow Control Loop			614066
HAMILTON MEDICAL			

SECTION 7 VALVE CONTROL

Used with marked Software Version

30	31	32	33
----	----	----	----



Hersteller	Überfachte	Untersuchte	Phase	Gez	18.11.08	Strecke
Geboirt. zu Schweddrift				Gez	09.07.09	CO
Pressure Control Loop			614065			
HAMILTON MEDICAL						

7.2 SERVO VALVE

The Servo Valve delivers flows to the patient. Depending on which mode is chosen, the Servo Valve is required to deliver mandatory or spontaneous breaths. An electronic servo control loop is located on three boards: the Flow Control Board, the Pressure Control Board and the Servo Power Board.

This electronic servo control loop is divided into two regulations: Pressure and Flow. For more information, see Drawings 614066 - Flow Regulation and 614065 - Pressure Regulation Loop.

7.3 EXPIRATORY VALVE

The Expiratory Valve is controlled by the control processor and electronics on the Pressure Control and Servo Power boards. The control processor sends the signal (U_{DA} Exp) to the Pressure Control board. This signal is amplified by the Servo Power Board and drives the Expiratory Valve.

The operation of the Expiratory Valve is closed during inspiration, partially closed during exhalation (if PEEP is required) or completely open.

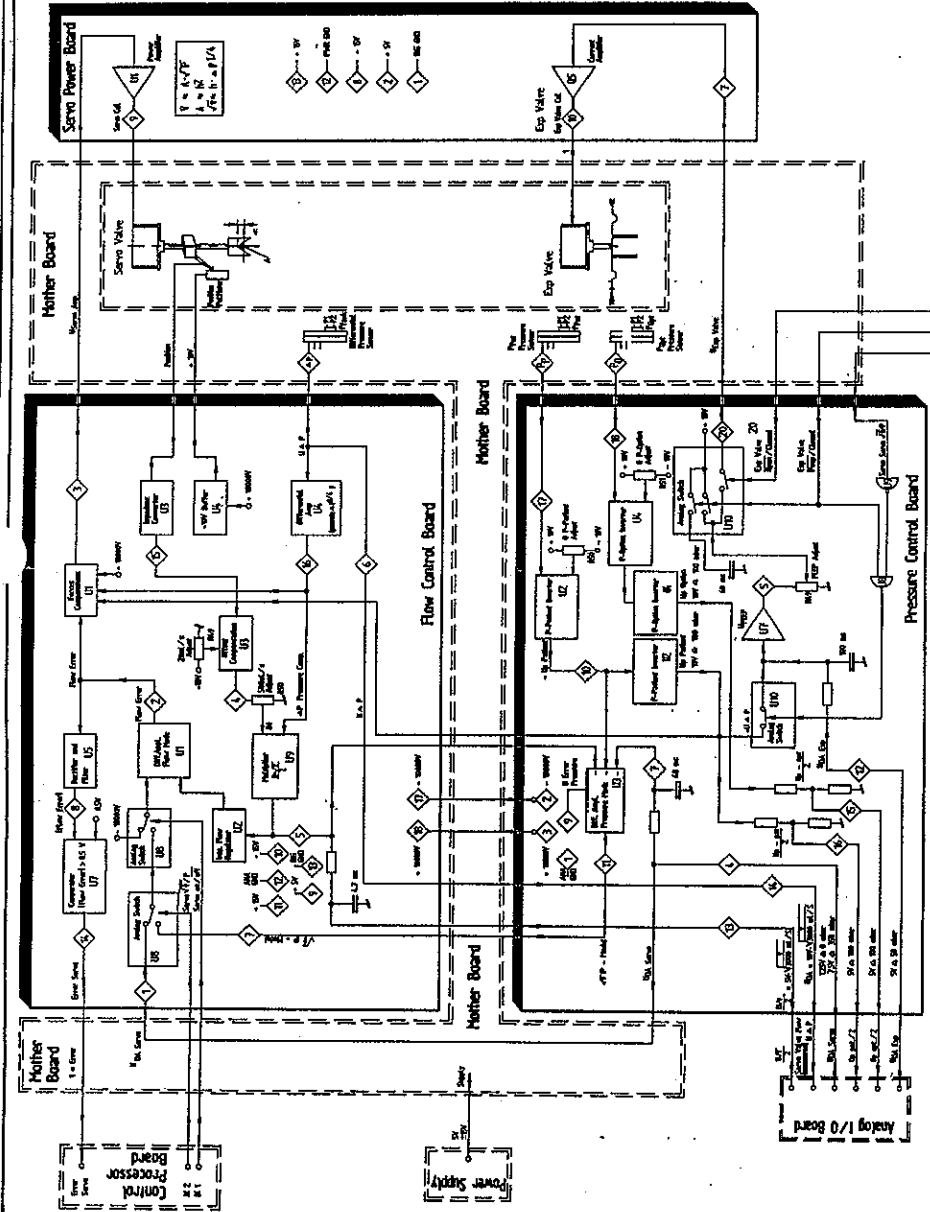
The three modes of the Expiratory Valve:

- completely opened ($I = 0$ mA)
- completely closed ($I = 550$ mA)
- PEEP ($I = 4,55$ mA/mbar)

The current source, U5 on the Pressure Control Board and Q5 on the Servo Power Board, controls the coil current.

SECTION 7 VALVE CONTROL

Check with material department



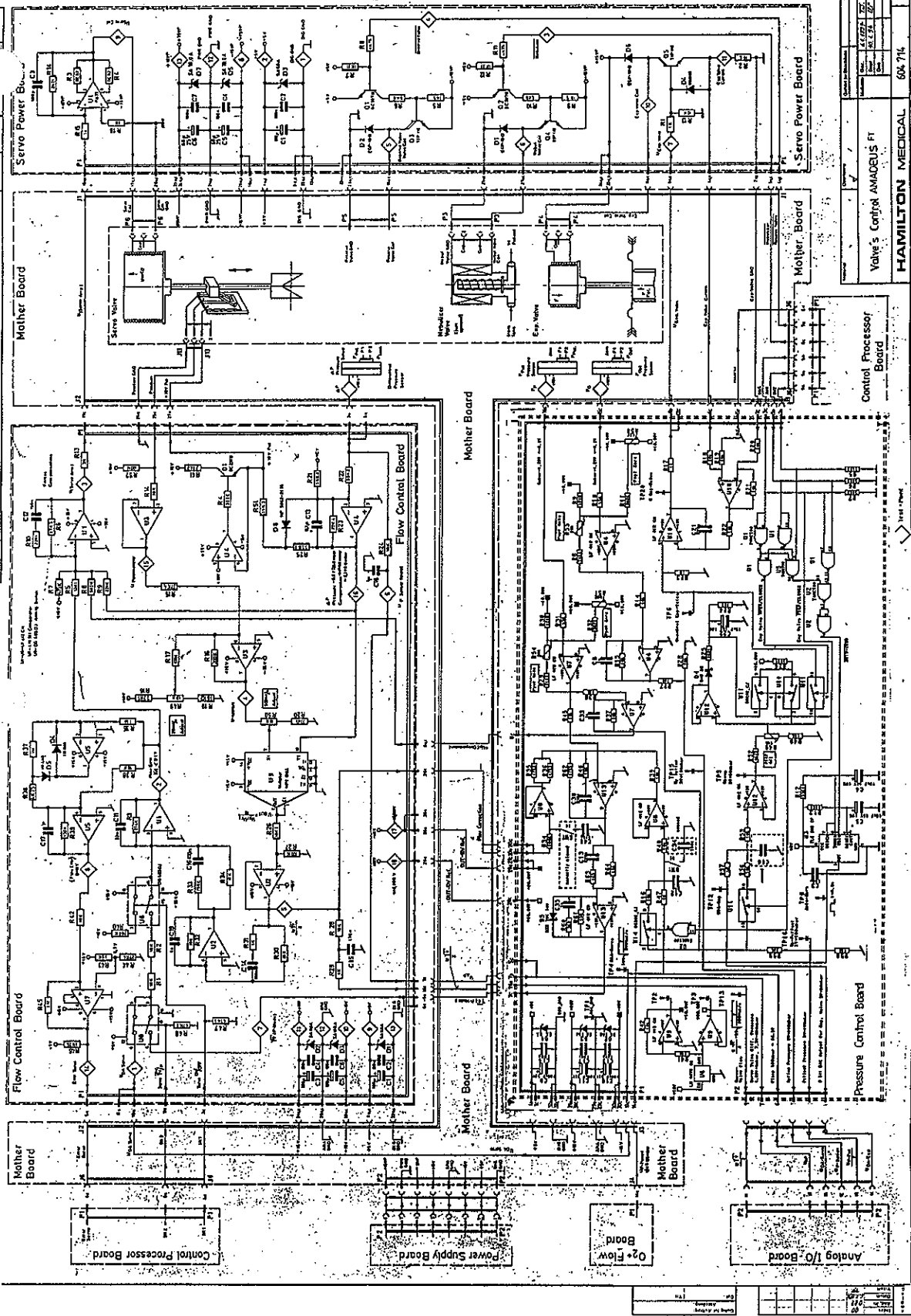
Diese Zeichnung gilt als dem jeweiligen Inhaber persönlich anvertraut. Das Eigentum und das Urheberrecht verbleibt uns. Ohne unsere schriftliche Genehmigung dürfen die Zeichnungen weder kopiert noch Dritten zugänglich gemacht werden.

A	Rev.	01	02
C	Send-Nr.	627	4759
M	Datum	23.1.91	27.3.92
D	Vision	Her.	Spdlin

Material		Übersicht	
Gehört zu Steuerklappe		Masse	
Valves Control AMADEUS		Unisoliererte	
HAMILTON MEDICAL		Masse	
23.2.1994 04:27min		Massstab	
HAMILTON MEDICAL AG		Gez. 1988-11-08 MD	
Service Manual AMADEUS		Gepr. 1989-11-07 O.C.	
Order-Nr. 610 221		Gez. 1992-03-27	
7-7		614057	

SECTION 7 VALVE CONTROL

Used with master Schematic, Version
18 30 91

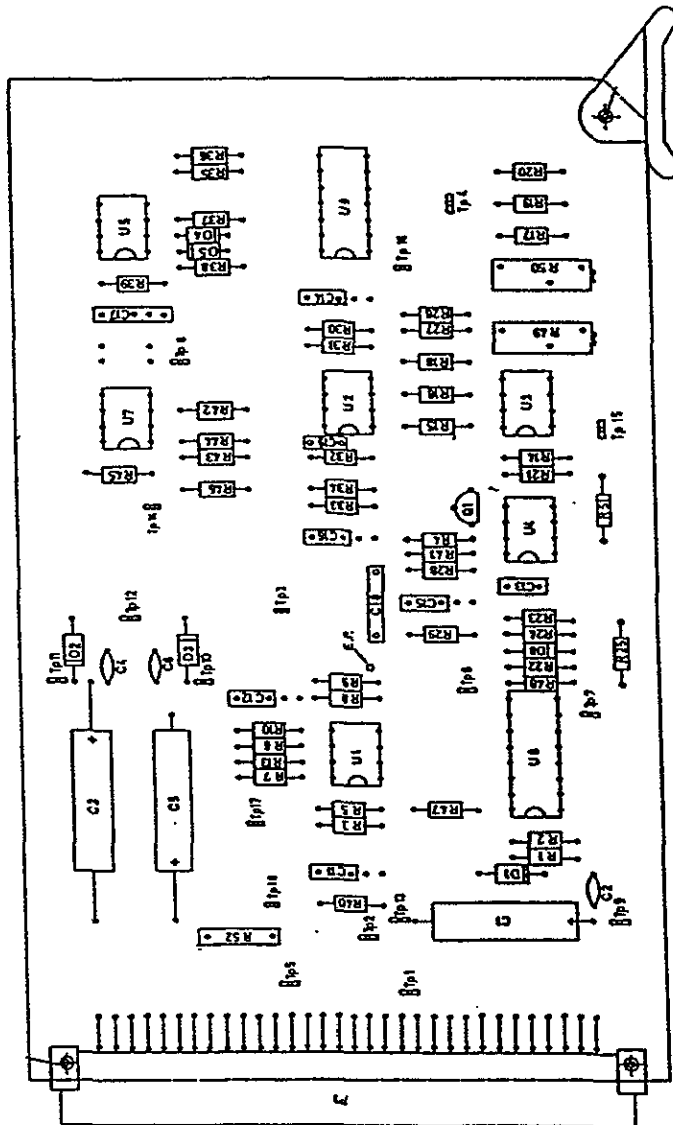


Control Processor Board	Valve's Control AMADEUS FT	60X 714
HAMILTON MEDICAL		

SECTION 7 VALVE CONTROL

Used with marked Software Version

30	31	32	33
----	----	----	----

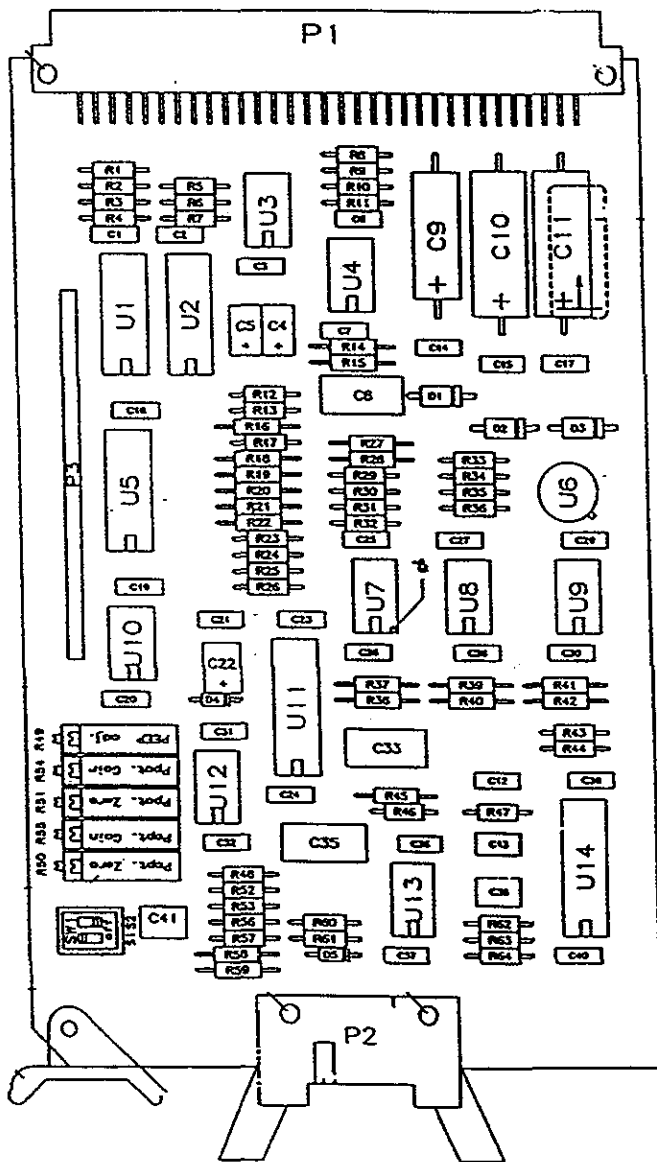


Allgemeine Informationen		Terminata		> 100.000		> 100.000		> 100.000	
100	100	100	100	100	100	100	100	100	100
100	100	100	100	100	100	100	100	100	100
100	100	100	100	100	100	100	100	100	100
Bezeichnung		150 410		150 410		150 410		150 410	
Hersteller		Hamilton Medical		Hamilton Medical		Hamilton Medical		Hamilton Medical	
Version		2.1.1		2.1.1		2.1.1		2.1.1	
Date		1994		1994		1994		1994	
Autor		Hamilton Medical		Hamilton Medical		Hamilton Medical		Hamilton Medical	
Projekt		Flow Control		Flow Control		Flow Control		Flow Control	
Teil		150 410		150 410		150 410		150 410	

SECTION 7 VALVE CONTROL

Used with marked Software Version

30 31 32 33



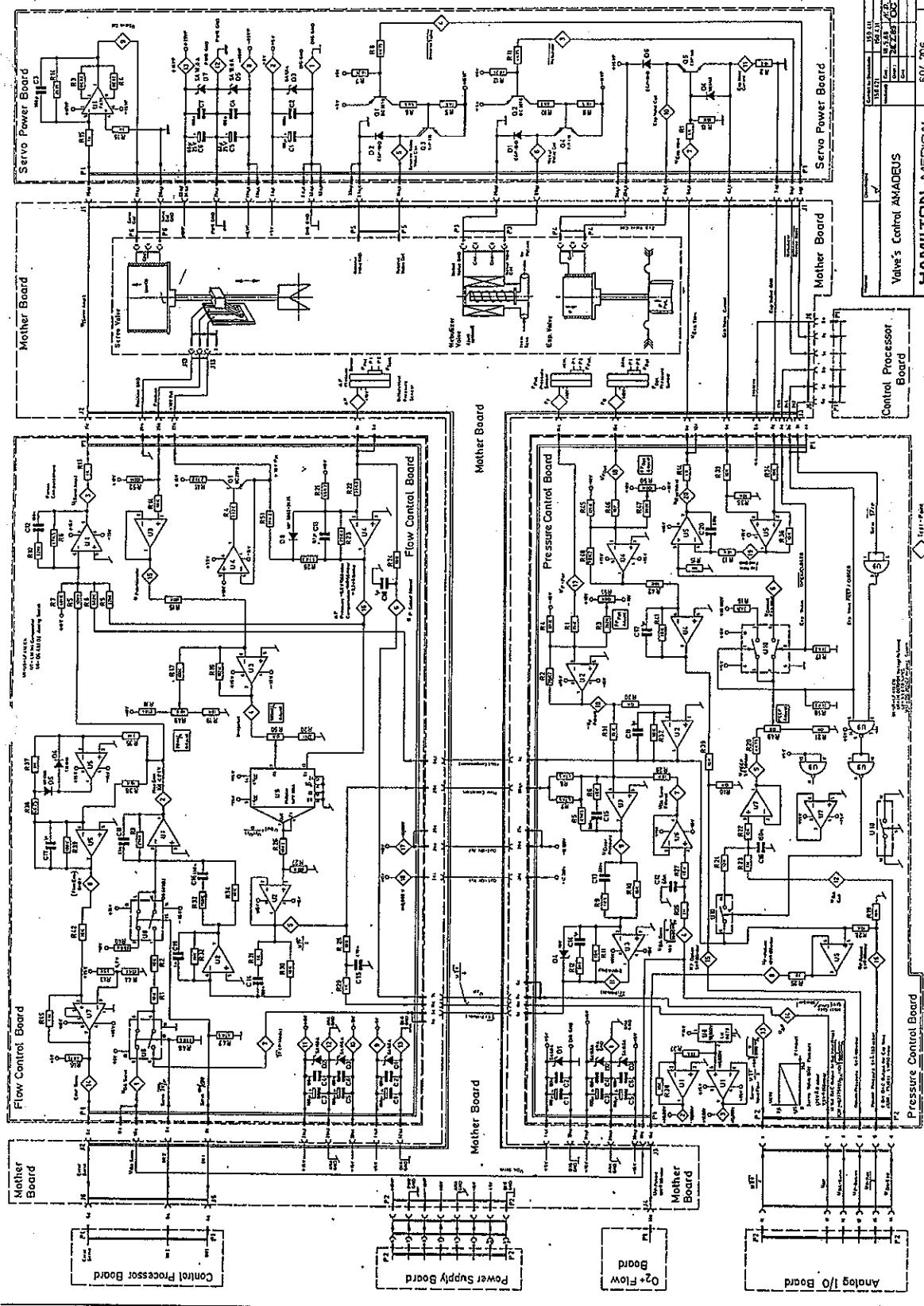
BESTUECKUNGSPLAN
Pressure Control Board
HAMILTON MEDICAL 150.425

MASTRA
2:1

REV. 1.0
REV. 2.0
REV. 3.0
REV. 4.0

SECTION 7 VALVE CONTROL

Used with manual 500-706, Version 3.0



Part No.	QTY	DESCRIPTION
100-101	1	VALVE CONTROL BOARD
100-102	1	VALVE CONTROL BOARD
100-103	1	VALVE CONTROL BOARD
100-104	1	VALVE CONTROL BOARD
100-105	1	VALVE CONTROL BOARD
100-106	1	VALVE CONTROL BOARD
100-107	1	VALVE CONTROL BOARD
100-108	1	VALVE CONTROL BOARD
100-109	1	VALVE CONTROL BOARD
100-110	1	VALVE CONTROL BOARD
100-111	1	VALVE CONTROL BOARD
100-112	1	VALVE CONTROL BOARD
100-113	1	VALVE CONTROL BOARD
100-114	1	VALVE CONTROL BOARD
100-115	1	VALVE CONTROL BOARD
100-116	1	VALVE CONTROL BOARD
100-117	1	VALVE CONTROL BOARD
100-118	1	VALVE CONTROL BOARD
100-119	1	VALVE CONTROL BOARD
100-120	1	VALVE CONTROL BOARD
100-121	1	VALVE CONTROL BOARD
100-122	1	VALVE CONTROL BOARD
100-123	1	VALVE CONTROL BOARD
100-124	1	VALVE CONTROL BOARD
100-125	1	VALVE CONTROL BOARD
100-126	1	VALVE CONTROL BOARD
100-127	1	VALVE CONTROL BOARD
100-128	1	VALVE CONTROL BOARD
100-129	1	VALVE CONTROL BOARD
100-130	1	VALVE CONTROL BOARD
100-131	1	VALVE CONTROL BOARD
100-132	1	VALVE CONTROL BOARD
100-133	1	VALVE CONTROL BOARD
100-134	1	VALVE CONTROL BOARD
100-135	1	VALVE CONTROL BOARD
100-136	1	VALVE CONTROL BOARD
100-137	1	VALVE CONTROL BOARD
100-138	1	VALVE CONTROL BOARD
100-139	1	VALVE CONTROL BOARD
100-140	1	VALVE CONTROL BOARD
100-141	1	VALVE CONTROL BOARD
100-142	1	VALVE CONTROL BOARD
100-143	1	VALVE CONTROL BOARD
100-144	1	VALVE CONTROL BOARD
100-145	1	VALVE CONTROL BOARD
100-146	1	VALVE CONTROL BOARD
100-147	1	VALVE CONTROL BOARD
100-148	1	VALVE CONTROL BOARD
100-149	1	VALVE CONTROL BOARD
100-150	1	VALVE CONTROL BOARD
100-151	1	VALVE CONTROL BOARD
100-152	1	VALVE CONTROL BOARD
100-153	1	VALVE CONTROL BOARD
100-154	1	VALVE CONTROL BOARD
100-155	1	VALVE CONTROL BOARD
100-156	1	VALVE CONTROL BOARD
100-157	1	VALVE CONTROL BOARD
100-158	1	VALVE CONTROL BOARD
100-159	1	VALVE CONTROL BOARD
100-160	1	VALVE CONTROL BOARD
100-161	1	VALVE CONTROL BOARD
100-162	1	VALVE CONTROL BOARD
100-163	1	VALVE CONTROL BOARD
100-164	1	VALVE CONTROL BOARD
100-165	1	VALVE CONTROL BOARD
100-166	1	VALVE CONTROL BOARD
100-167	1	VALVE CONTROL BOARD
100-168	1	VALVE CONTROL BOARD
100-169	1	VALVE CONTROL BOARD
100-170	1	VALVE CONTROL BOARD
100-171	1	VALVE CONTROL BOARD
100-172	1	VALVE CONTROL BOARD
100-173	1	VALVE CONTROL BOARD
100-174	1	VALVE CONTROL BOARD
100-175	1	VALVE CONTROL BOARD
100-176	1	VALVE CONTROL BOARD
100-177	1	VALVE CONTROL BOARD
100-178	1	VALVE CONTROL BOARD
100-179	1	VALVE CONTROL BOARD
100-180	1	VALVE CONTROL BOARD
100-181	1	VALVE CONTROL BOARD
100-182	1	VALVE CONTROL BOARD
100-183	1	VALVE CONTROL BOARD
100-184	1	VALVE CONTROL BOARD
100-185	1	VALVE CONTROL BOARD
100-186	1	VALVE CONTROL BOARD
100-187	1	VALVE CONTROL BOARD
100-188	1	VALVE CONTROL BOARD
100-189	1	VALVE CONTROL BOARD
100-190	1	VALVE CONTROL BOARD
100-191	1	VALVE CONTROL BOARD
100-192	1	VALVE CONTROL BOARD
100-193	1	VALVE CONTROL BOARD
100-194	1	VALVE CONTROL BOARD
100-195	1	VALVE CONTROL BOARD
100-196	1	VALVE CONTROL BOARD
100-197	1	VALVE CONTROL BOARD
100-198	1	VALVE CONTROL BOARD
100-199	1	VALVE CONTROL BOARD
100-200	1	VALVE CONTROL BOARD

22.2.1094 8.420m
 HAMILTON MEDICAL AG
 Service Manual AMADEUS
 Order-No. 610 221
 7-12

HAMILTON MEDICAL
 Valve's Control AMADEUS
 500-706

8 MIXER, O₂ AND FLOW BOARD DESCRIPTION 8-2

MIXER, O₂ AND FLOW BOARD	8-3
614056 Block Diagram	8-3
604703/1 Schematic Diagram	8-4
604703/2 Schematic Diagram	8-5
153380 Board Drawing	8-6
153330 Board Drawing	8-7
 O₂ CELL BOARD	 8-8
604560 Schematic Diagram	8-8
150485 Board Drawing	8-9
604558 Schematic Diagram	8-10
150480 Board Drawing	8-11

8 MIXER, O₂ AND FLOW BOARD DESCRIPTION

The AMADEUS has a very sophisticated electronic mixer and this requires its very own microprocessing system. The microprocessor and the mixer electronics for this system are located on the Mixer, O₂ and Flow Board. In addition to the mixer electronics, this board contains the electronics that process the signals from the O₂ cell board and from the flow sensor transducer for flow measurement.

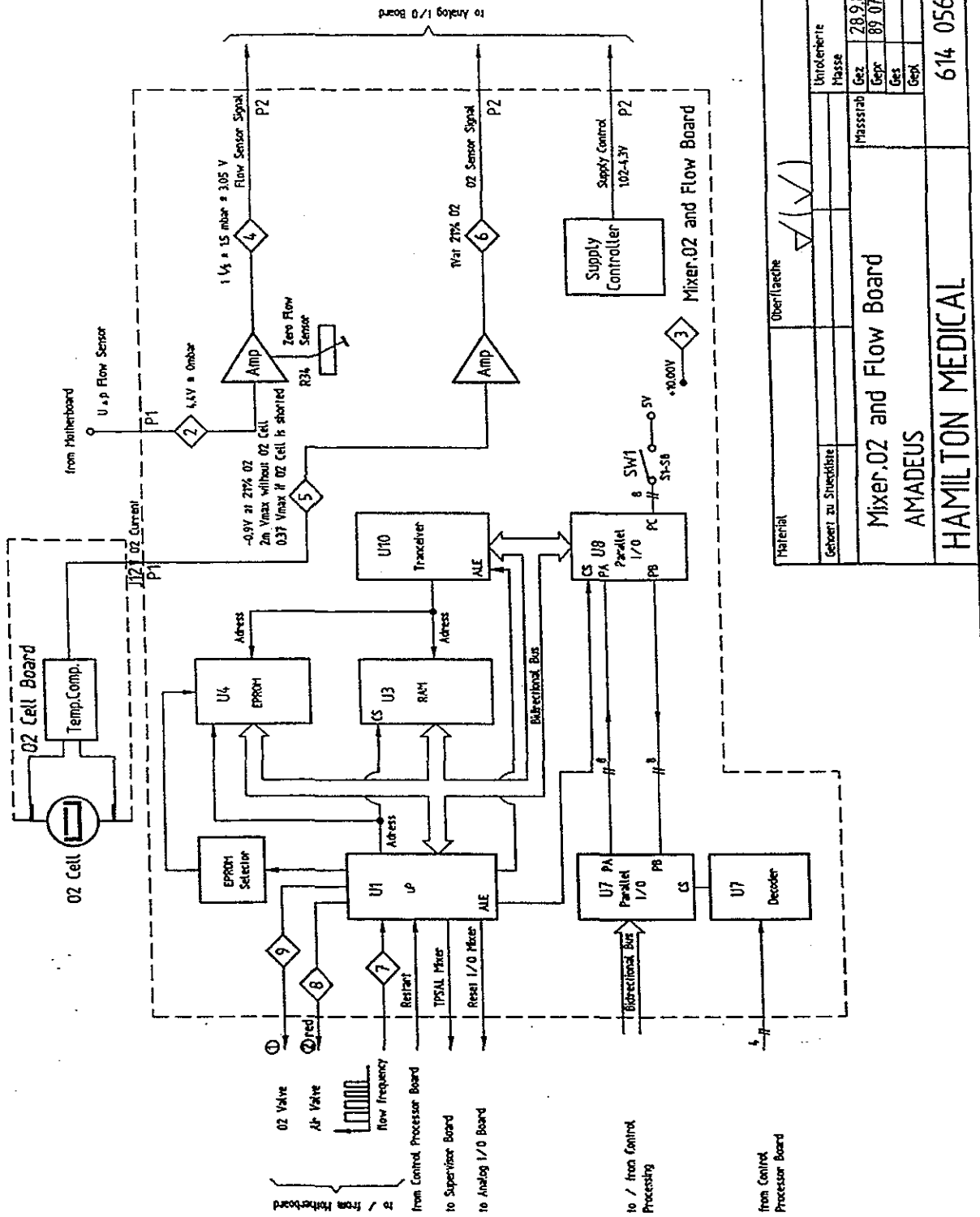
There is one adjustable potentiometer for flow measurement mounted near the top. It is used to adjust the flow sensor pressure transducer to zero. A set of dip switches allows the mixer to be adjusted to the right altitude. For a complete description of how the electronic mixer functions, please see Section 10.

SECTION 8 MIXER/O₂ AND FLOW BOARD

Used with marked Software Version

30	31	32	33
----	----	----	----

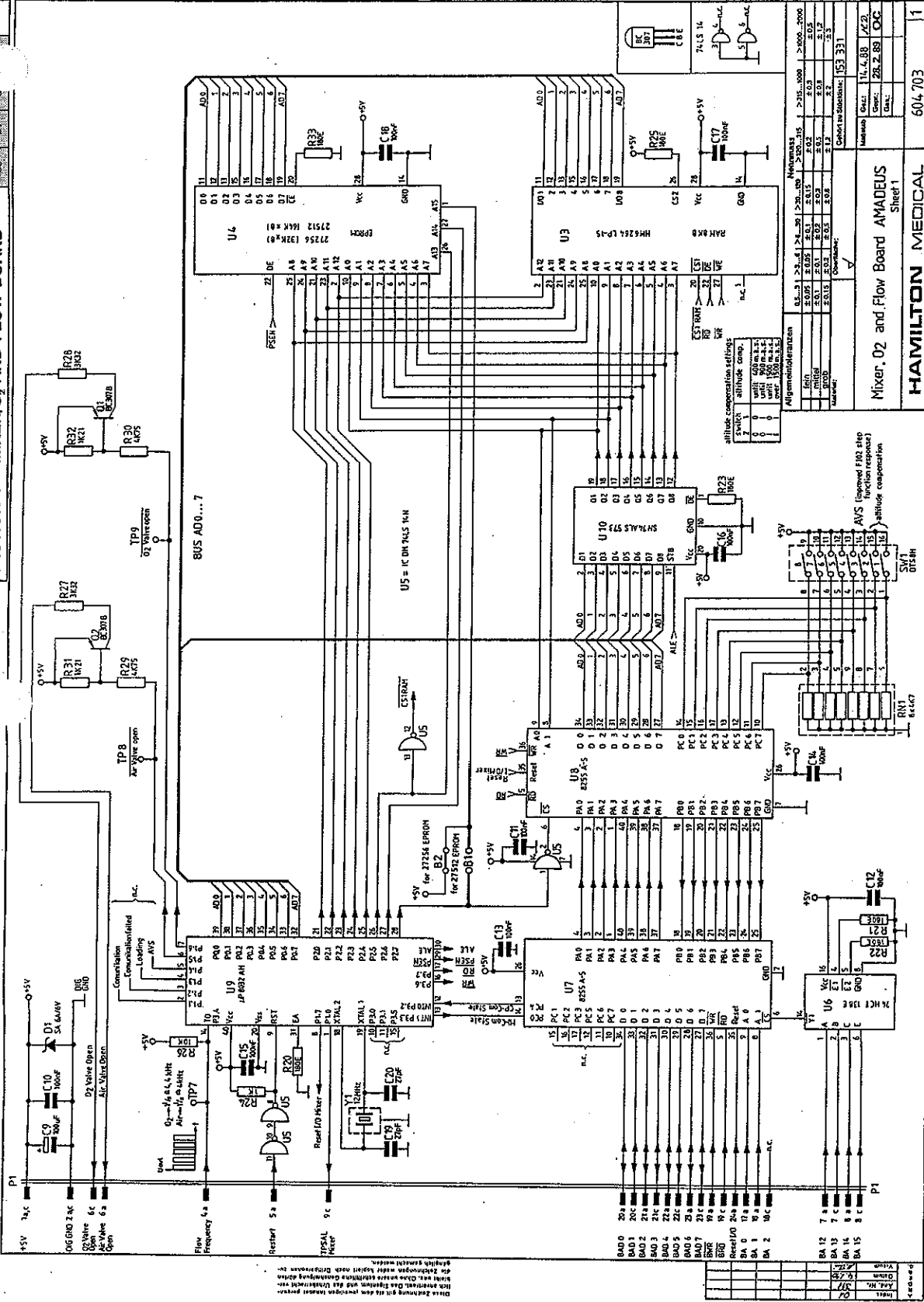
Wiese Zeichnung gilt als dem jeweiligen Inhaber persoenlich anvertraut. Das Eigentum und das Urheberrecht verbleibt uns. Ohne unsere schriftliche Genehmigung duerfen die Zeichnungen weder kopiert noch Dritten persoenen zugänglich gemacht werden.



Material		Oberflaeche		Unteroberflaeche	
Gehoert zu Stückliste		Platte		Platte	
Mixer, O ₂ and Flow Board		Massstab		Gez. 28.9.88 M.D.	
AMADEUS		Gepr.		Gepr. 07.11.00	
HAMILTON MEDICAL		Gepr.		Gepr.	
				614 056	

SECTION 8 MIXER/O₂ AND FLOW BOARD

Used with marked Software Version



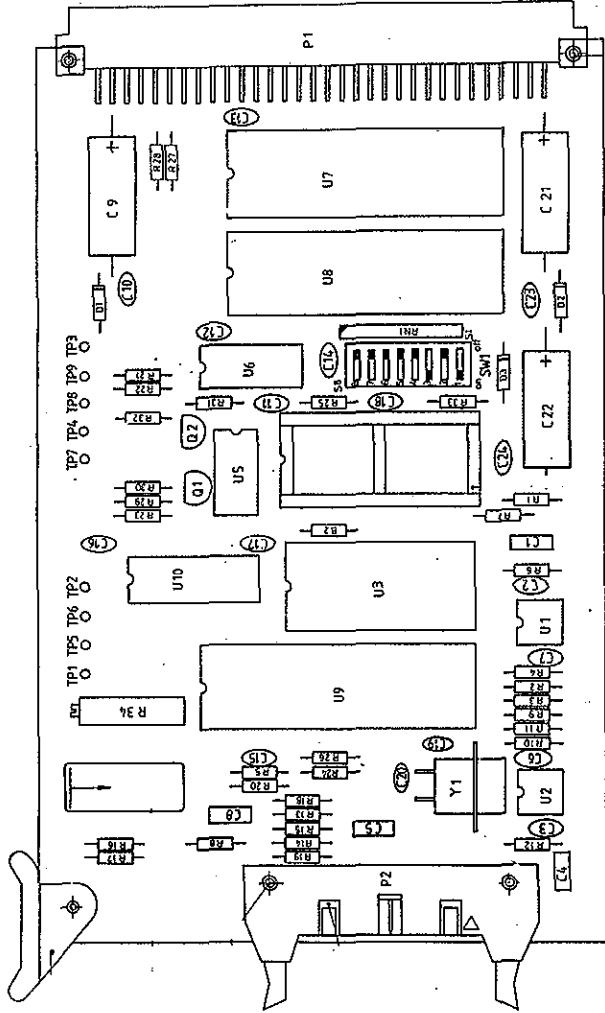
Pin	Symbol	Function
1	VCC	+5V
2	A1	Input
3	A2	Input
4	A3	Input
5	A4	Input
6	A5	Input
7	A6	Input
8	A7	Input
9	A8	Input
10	A9	Input
11	A10	Input
12	A11	Input
13	A12	Input
14	A13	Input
15	A14	Input
16	A15	Input
17	A16	Input
18	A17	Input
19	A18	Input
20	A19	Input
21	A20	Input
22	A21	Input
23	A22	Input
24	A23	Input
25	A24	Input
26	A25	Input
27	A26	Input
28	A27	Input
29	A28	Input
30	A29	Input
31	A30	Input
32	A31	Input
33	A32	Input
34	A33	Input
35	A34	Input
36	A35	Input
37	A36	Input
38	A37	Input
39	A38	Input
40	A39	Input
41	A40	Input
42	A41	Input
43	A42	Input
44	A43	Input
45	A44	Input
46	A45	Input
47	A46	Input
48	A47	Input
49	A48	Input
50	A49	Input
51	A50	Input
52	A51	Input
53	A52	Input
54	A53	Input
55	A54	Input
56	A55	Input
57	A56	Input
58	A57	Input
59	A58	Input
60	A59	Input
61	A60	Input
62	A61	Input
63	A62	Input
64	A63	Input
65	A64	Input
66	A65	Input
67	A66	Input
68	A67	Input
69	A68	Input
70	A69	Input
71	A70	Input
72	A71	Input
73	A72	Input
74	A73	Input
75	A74	Input
76	A75	Input
77	A76	Input
78	A77	Input
79	A78	Input
80	A79	Input
81	A80	Input
82	A81	Input
83	A82	Input
84	A83	Input
85	A84	Input
86	A85	Input
87	A86	Input
88	A87	Input
89	A88	Input
90	A89	Input
91	A90	Input
92	A91	Input
93	A92	Input
94	A93	Input
95	A94	Input
96	A95	Input
97	A96	Input
98	A97	Input
99	A98	Input
100	A99	Input
101	A100	Input

Mixer, O₂ and Flow Board AMADEUS
Sheet 1
HAMILTON MEDICAL
604.703

SECTION 8 MIXER/O₂ AND FLOW BOARD

Used with marked Schemata Version

30 31 32



Diese Zeichnung gilt für den jetzt angezeigten Baudeckel. Die Bauteile sind gegenüber dem Baudeckel angeordnet. Die Bauteile sind gegenüber dem Baudeckel angeordnet. Die Bauteile sind gegenüber dem Baudeckel angeordnet.

Form	00
Datum	10.03.77
Aut. Nr.	
Zeichner	

Allgemeintechnische Daten			
Nennwert	0,5 - 3	0,5 - 1	1,5 - 30
Genauigkeit	± 0,03	± 0,05	± 0,01
Min. Wert	0,03	0,05	0,01
Max. Wert	3	30	300
Zusätzliche Daten			
Material	Edelstahl		
Montagehinweise			
Montage	2:1		
Wartung	2:1		
Reparatur	2:1		
Einbau	2:1		
Abnahme	2:1		
Prüfung	2:1		
Abnahme	2:1		

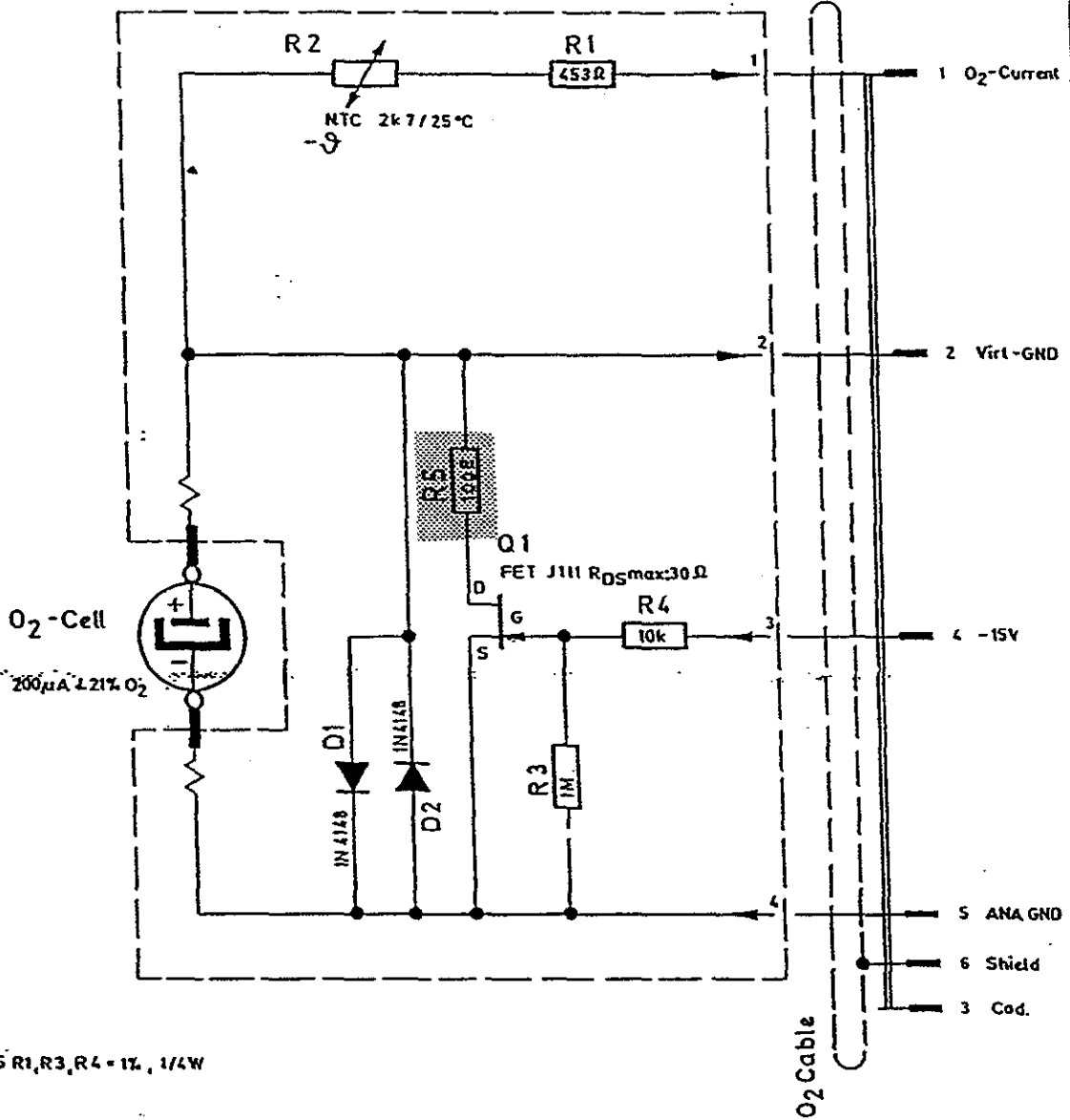
Mixer/O₂ Flow Board 33 (AMADEUS FT) 2:1
HAMILTON MEDICAL
 153380

SECTION 8 MIXER/O₂ AND FLOW BOARD

Used with marked Software Version

30	31	32	33
----	----	----	----

to / from
Mother
Board



R5 R1, R3, R4 = 1%, 1/4W

Allgemeintoleranzen

	Nennmass							
	0.5 . 3	>3 . 6	>6 . 30	>30 . 120	>120...315	>315...1000	>1000 . 2000	
fein	± 0.05	± 0.05	± 0.1	± 0.15	± 0.2	± 0.3	± 0.5	
mittel	± 0.1	± 0.1	± 0.2	± 0.3	± 0.5	± 0.8	± 1.2	
grob	± 0.15	± 0.2	± 0.5	± 0.8	± 1.2	± 2	± 3	

Material:

Oberfläche:

Gehört zu Stückliste:

150 485

Index	Änd. Nr.	Datum	Visum
01	391	4.1.89	[Signature]

O₂-Cell-Board

Maßstab

Gez.

21.12.89 U.Fluri

Gepr

21.12.89 P.Mo.

Ges.

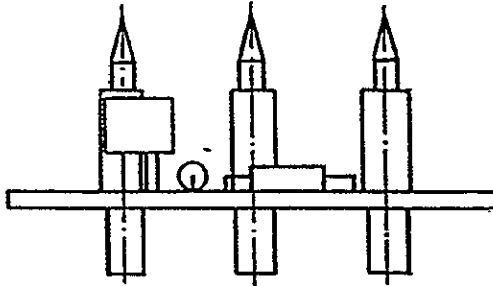
HAMILTON MEDICAL

604 560

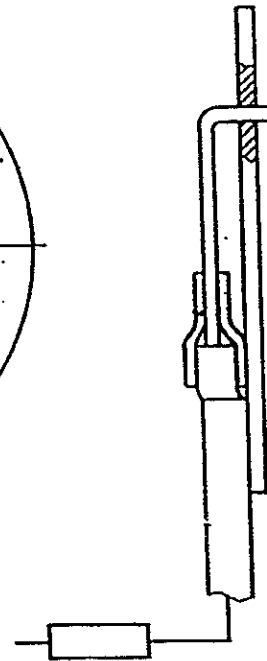
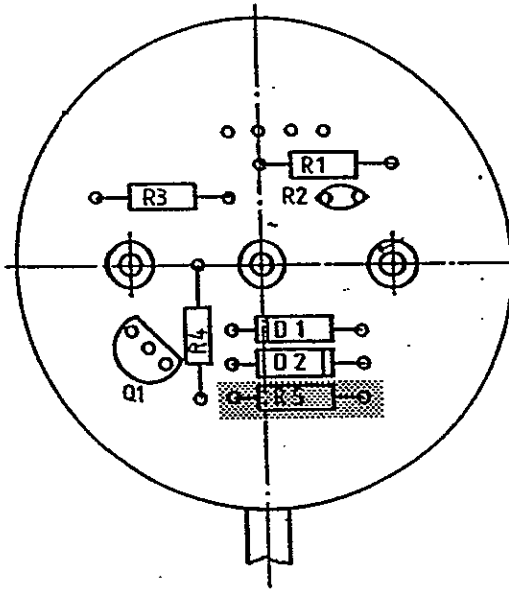
SECTION 8 MIXER/O₂ AND FLOW BOARD

Used with marked Software Version

30	31	32	33
----	----	----	----



Nach NTC-Test: Kabellänge gekürzt auf 660 mm



Kabel	Print
braun	1
weiss	2
grün	3
gelb	4

01	02	03
3.9.1	196	8.8.8
4.1.10	2.9.10	1.8.91
Alt	Edel	Alu
Index	And. Nr.	Datum
Visum		

Allgemeintoleranzen	Nennmass						
	0,5...3	>3...6	>6...30	>30...120	>120...315	>315...1000	>1000...2000
fein	±0,05	±0,05	±0,1	±0,15	±0,2	±0,3	±0,5
mittel	±0,1	±0,1	±0,2	±0,3	±0,5	±0,8	±1,2
grob	±0,15	±0,2	±0,5	±0,8	±1,2	±2	±3

Material:	Oberfläche:	Gehört zu Stückliste:	151 440
	✓	153 600	

O ₂ Cell Board kpl.	Maßstab 2:1	Gez.:	3.1.90	U.F.
		Gepr.:	3.1.90	O.C.
		Ges.:		

HAMILTON MEDICAL

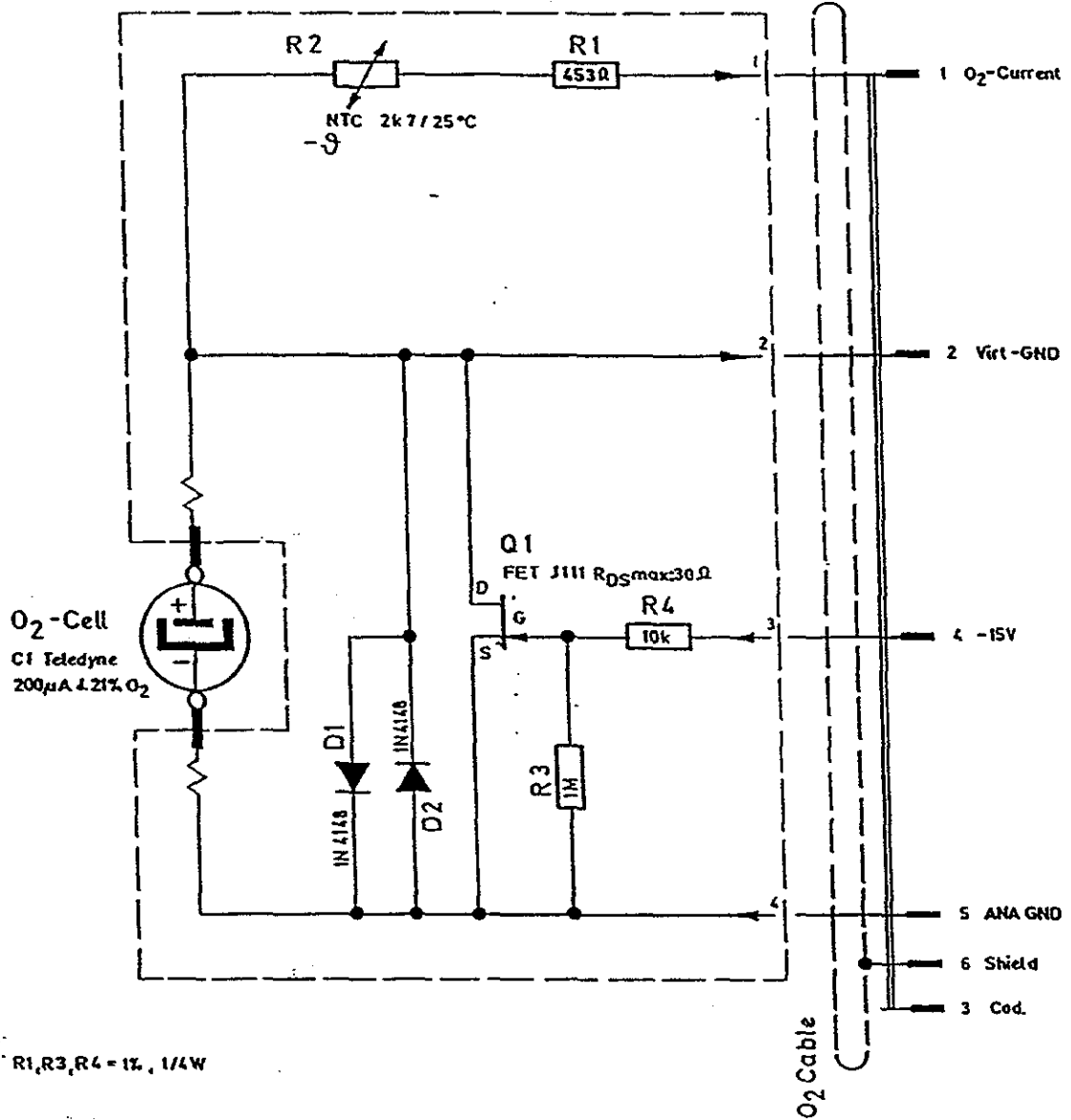
150485

SECTION 8 MIXER/O₂ AND FLOW BOARD

Used with marked Software Version

30	31	32	33
----	----	----	----

to / from
Mother
Board



R1, R3, R4 = 1%, 1/4W

Indes	
Änd. Nr.	
Datum	
Visum	

Allgemeintoleranzen

	Nennmass						
	0,5...3	>3...6	>6...30	>30...120	>120...315	>315...1000	>1000...2000
fein	±0,05	±0,05	±0,1	±0,15	±0,2	±0,3	±0,5
mittel	±0,1	±0,1	±0,2	±0,3	±0,5	±0,8	±1,2
grob	±0,15	±0,2	±0,5	±0,8	±1,2	±2	±3

Material:

Oberfläche:



Gehört zu Stückliste:

150 481

Maßstab

Gez.: 26.3.84

Gepr.: 28.2.89

Ges.:

OC

O₂- Cell- Board

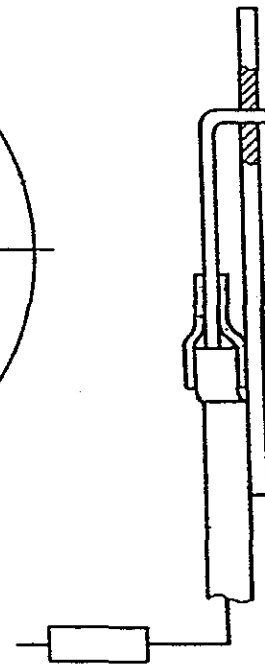
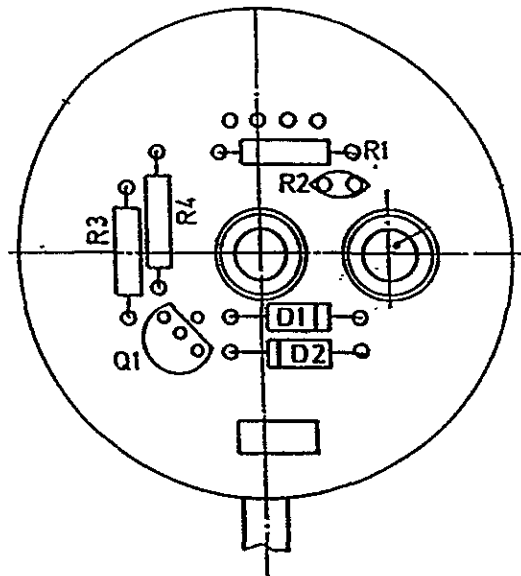
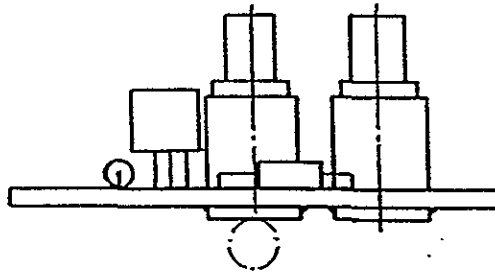
HAMILTON MEDICAL

604 558

SECTION 8 MIXER/O₂ AND FLOW BOARD

Used with marked Software Version

30 31 32 33



Kabel	Print
braun	1
weiss	2
grün	3
gelb	4

Index	A	01
Änd. Nr.	27	285
Datum	6.8.89	29.11.89
Visum	<i>[Signature]</i>	<i>[Signature]</i>

Allgemeintoleranzen		Nennmass						
		0.5...3	>3...6	>6...30	>30...120	>120...315	>315...1000	>1000...2000
	fein	±0.05	±0.05	±0.1	±0.15	±0.2	±0.3	±0.5
	mittel	±0.1	±0.1	±0.2	±0.3	±0.5	±0.8	±1.2
	grob	±0.15	±0.2	±0.5	±0.8	±1.2	±2	±3
Material:		Oberfläche:			Gehört zu Stückliste:		151 420	
O ₂ Cell Board		<input checked="" type="checkbox"/>			Maßstab	Gez.:	30.11.83	<i>ge</i>
					2:1	Gepr.:	28.2.89	<i>OC</i>
						Ges.:		

HAMILTON MEDICAL

150 480

SECTION 9 SUPERVISOR BOARD

Used with marked Software Version

30	31	32	33	
----	----	----	----	--

9 SUPERVISOR BOARD DESCRIPTION	9-2
SUPERVISOR BOARD	9-3
614055 Block Diagram	9-3
604702 Schematic Drawing	9-4
153320 Board Drawing	9-5
BUZZER BOARD	9-6
604710 Schematic Drawing	9-6
153360 Board Drawing	9-7

9 SUPERVISOR BOARD DESCRIPTION

The Supervisor Board in the AMADEUS performs a variety of functions. The "restart" signal is generated and by delaying this signal through some electronics, we produce the "Ram enable" Signal. This board contains the buzzer and the circuitry that activates the "Power alarm" LED when the buzzer is in use. The Ni-Cad accumulator and its recharging circuitry is also located on this board. Under and overvoltage comparators check the +5V coming from the power supply.

There are three sets of dip switches on the Supervisory board. Two of these sets are located at the rear of the board and protrude through a slot in the back panel which enables easy user access.

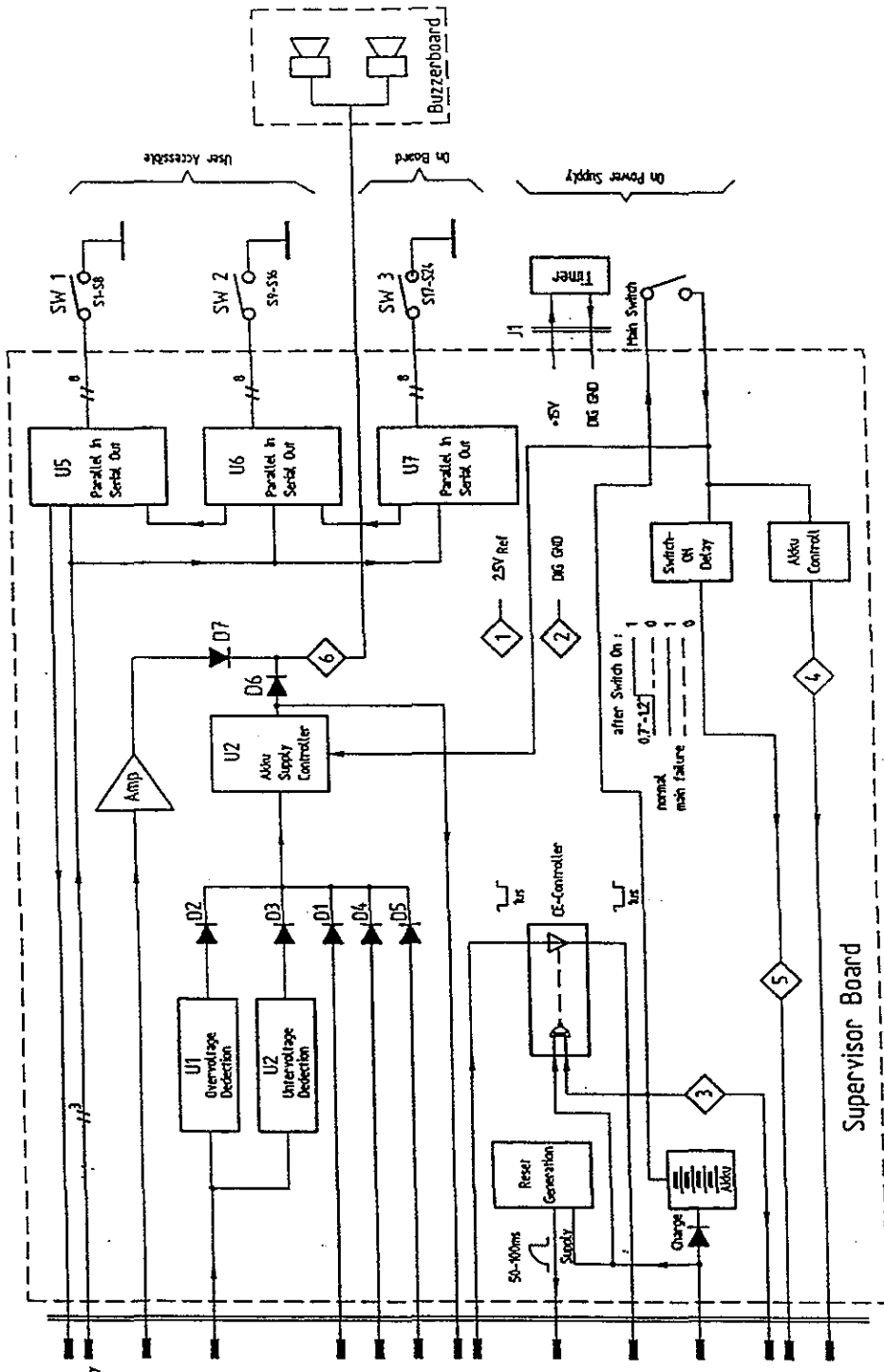
CAUTION

Lithium battery is in danger of exploding if the battery is incorrectly replaced. Replace only with same or equivalent type recommended by the equipment manufacturer. Discard used batteries according to the manufacturer's instructions.

SECTION 9 SUPERVISOR BOARD

Used with marked Software Version

30	31	32	33
----	----	----	----



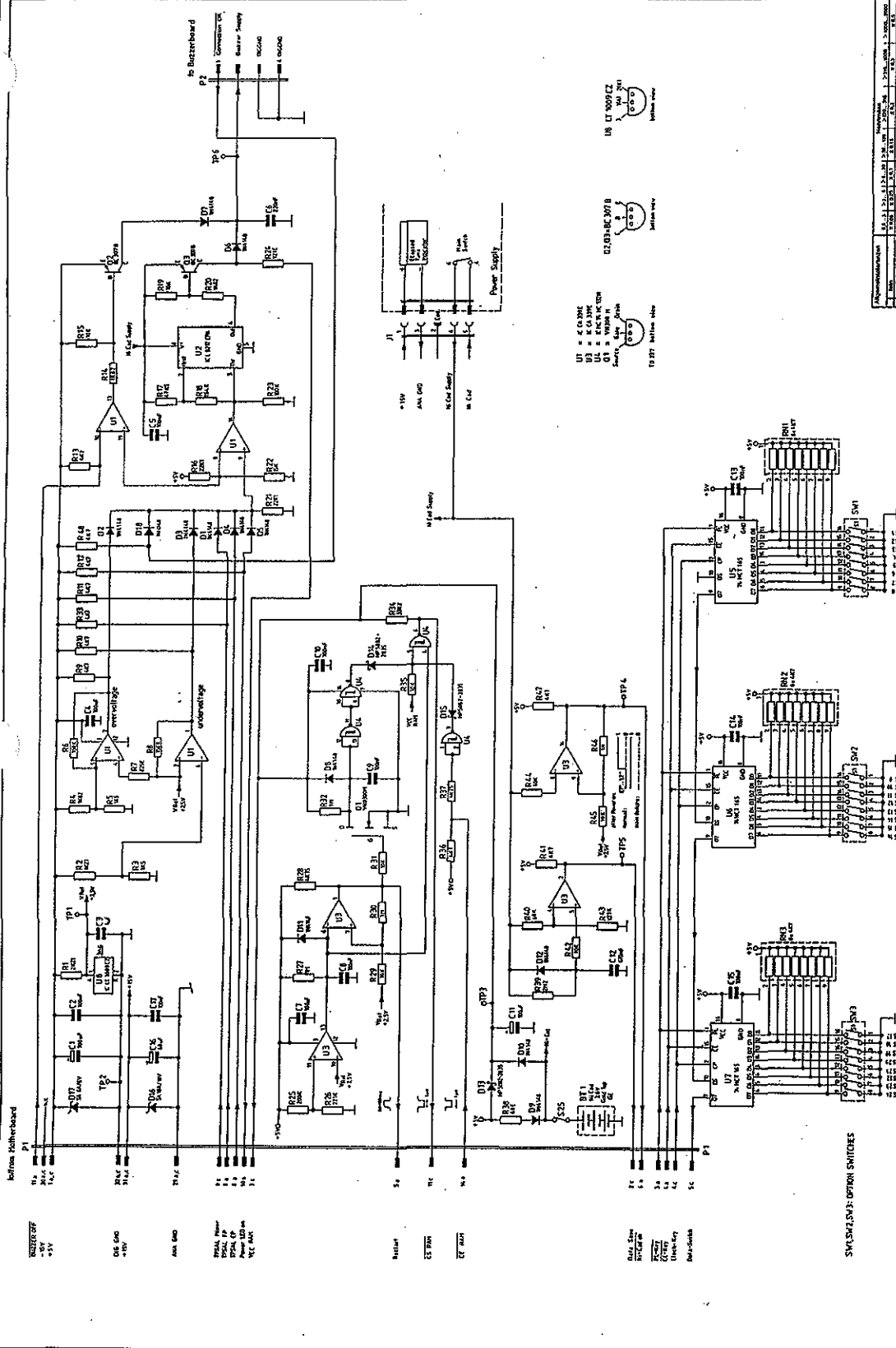
Diese Zeichnung gilt als dem jeweiligen Inhaber persönlich
 anvertraut. Das Eigentum und das Urheberrecht verbleibt uns.
 Ohne unsere schriftliche Genehmigung dürfen die Zeichnungen
 weder kopiert noch Dritten zugänglich gemacht werden.

22.2.1994 8.50am

Material	Überflächne		Untolerante	
Geberit zu Stückliste				
Supervisor Board AMADEUS		Masse	88 10 06	M.D.
HAMILTON MEDICAL		Gepr	89 07 11	O.C.
		Gepr		
		Gepr		
		614 055		

SECTION 9 SUPERVISOR BOARD

Used with revised 5000 Version



Part No.	Quantity	Description	Manufacturer
U1	1	7805	ON
U2	1	7805	ON
U3	1	7413	ON
U4	1	7413	ON
U5	1	7413	ON
U6	1	7413	ON
U7	1	7413	ON
D1	1	1N4148	ON
D2	1	1N4148	ON
D3	1	1N4148	ON
D4	1	1N4148	ON
D5	1	1N4148	ON
D6	1	1N4148	ON
D7	1	1N4148	ON
D8	1	1N4148	ON
L1	1	LED	ON
L2	1	LED	ON
L3	1	LED	ON
L4	1	LED	ON
R1	1	10K	ON
R2	1	10K	ON
R3	1	10K	ON
R4	1	10K	ON
R5	1	10K	ON
R6	1	10K	ON
R7	1	10K	ON
R8	1	10K	ON
R9	1	10K	ON
R10	1	10K	ON
R11	1	10K	ON
R12	1	10K	ON
R13	1	10K	ON
R14	1	10K	ON
R15	1	10K	ON
R16	1	10K	ON
R17	1	10K	ON
R18	1	10K	ON
R19	1	10K	ON
R20	1	10K	ON
R21	1	10K	ON
R22	1	10K	ON
R23	1	10K	ON
R24	1	10K	ON
R25	1	10K	ON
R26	1	10K	ON
R27	1	10K	ON
R28	1	10K	ON
R29	1	10K	ON
R30	1	10K	ON
C1	1	100uF	ON
C2	1	100uF	ON
C3	1	100uF	ON
C4	1	100uF	ON
C5	1	100uF	ON
C6	1	100uF	ON
C7	1	100uF	ON
C8	1	100uF	ON
C9	1	100uF	ON
C10	1	100uF	ON

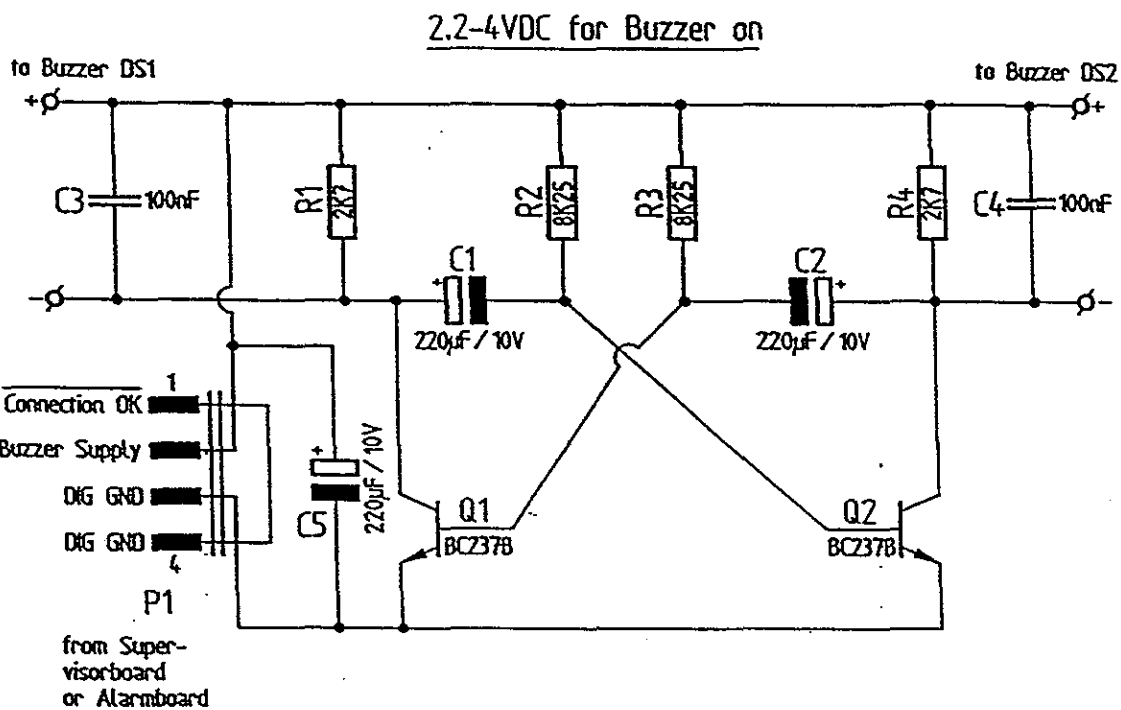
22.2.1984 4550mm
 HAMILTON MEDICAL AG
 Service Manual AMADEUS
 Order-No. 610 221
 9-4

© 1984 Hamilton Medical AG. All rights reserved. This document is the property of Hamilton Medical AG. It is not to be reproduced, stored in a retrieval system, or transmitted in any form or by any means, electronic, mechanical, photocopying, recording, or by any information storage and retrieval system, without the prior written permission of Hamilton Medical AG.

SECTION 9 SUPERVISOR BOARD

Used with marked Software Version

30	31	32	33
----	----	----	----



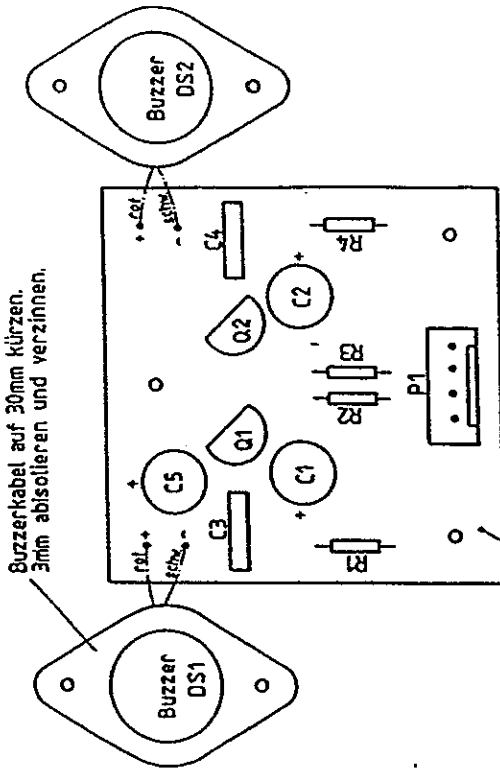
Material	Oberflaeche		
	∇(∇/)		
Gehört zu Stueckliste			Untolerierte Masse
Schema Buzzerboard		Massstab	Gez 90 03 22 Spadin
			Gepr 90 04 19 P.Mo.
			Ges
			Gepl
HAMILTON MEDICAL		604710	

22. 2. 1994 8.50am

SECTION 9 SUPERVISOR BOARD

Used with marked Software Version

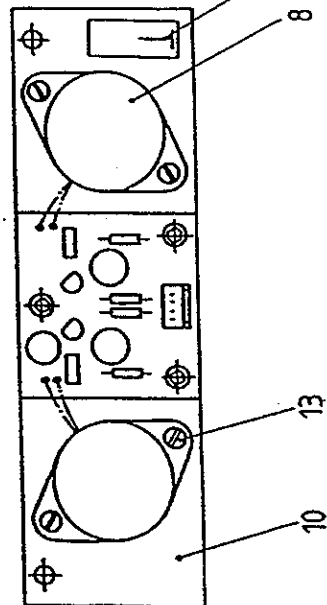
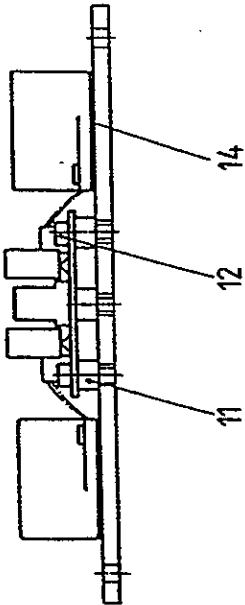
30	31	32	33
----	----	----	----



Allgemeintoleranzen		Nennmaße	
0,5...3	> 2...8	> 6...30	> 30...120
± 0,05	± 0,05	± 0,1	± 0,15
± 0,1	± 0,1	± 0,2	± 0,3
± 0,15	± 0,2	± 0,3	± 0,5
± 0,2	± 0,3	± 0,5	± 0,8
± 0,3	± 0,5	± 0,8	± 1,2
± 0,5	± 0,8	± 1,2	± 2,0
± 0,8	± 1,2	± 2,0	± 3,0
± 1,2	± 2,0	± 3,0	± 5,0
± 2,0	± 3,0	± 5,0	± 10,0
± 3,0	± 5,0	± 10,0	± 20,0
± 5,0	± 10,0	± 20,0	± 50,0
± 10,0	± 20,0	± 50,0	± 100,0
± 20,0	± 50,0	± 100,0	± 200,0
± 50,0	± 100,0	± 200,0	± 500,0
± 100,0	± 200,0	± 500,0	± 1000,0
± 200,0	± 500,0	± 1000,0	± 2000,0

Gehört zu Stückliste		151 530
Material		153 670
Material	Gez	19.2.90 Spadin
Gez	Gez	17.4.90 p. Mo.
Gez	Gez	
Gez	Gez	

Bestückungsplan Buzzerboard kpl.		153 360
HAMILTON MEDICAL		



01	02	03	04	05	06	07	08	09	10	11	12	13	14	15	16	17	18	19	20	21	22	23	24	25	26	27	28	29	30	31	32	33	34	35	36	37	38	39	40	41	42	43	44	45	46	47	48	49	50
----	----	----	----	----	----	----	----	----	----	----	----	----	----	----	----	----	----	----	----	----	----	----	----	----	----	----	----	----	----	----	----	----	----	----	----	----	----	----	----	----	----	----	----	----	----	----	----	----	----

SECTION 10 PNEUMATIC OF THE AMADEUS

Used with marked Software Version

30	31	32	33	
----	----	----	----	--

10	PNEUMATIC OF THE AMADEUS	10-2
10.1	Supply pressure section (2-6 bar)	10-2
10.2	Reservoir pressure section (200-340 mbar)	10-2
10.3	Patient pressure section (0 to 110 mbar)	10-2
	AMADEUS PNEUMATIC DIAGRAM	10-3
610316	Block Schematic	10-3
610304	Block Schematic	10-4
10.4	Electronic mixing system	10-5
10.5	Inspiratory Valve (Servo Valve)	10-6
10.6	Expiratory Valve	10-7
10.7	Ambient/High Pressure Valve	10-8
10.8	Flow sensor	10-8

10 PNEUMATIC OF THE AMADEUS

The pneumatics of the AMADEUS can be subdivided into three different pressure levels: Supply pressure, Reservoir pressure and Patient pressure.

10.1 Supply pressure section (2-6 bar)

The Supply pressure section consists of the gas inlets and the electronic mixer. Oxygen and air enter the ventilator at the rear via two water separators with built-in 0.01 micron filters. There is a check valve in each line that prevents any back flow of gas. The gas then enters the electronic mixer system which contains two solenoids and a pneumatic flow resistor. The differential pressure across the flow resistor is measured and this value allows the mixer microprocessor to calculate how long each solenoid should be opened to obtain the correct F_{O_2} and tank pressure of 340 mbar.

10.2 Reservoir pressure section (200-340 mbar)

The reservoir tank is made of aluminium and holds about 8 litres of compressed gas. The electronic mixer keeps the tank pressure at about 340 mbar. Flow is measured and delivered to the patient by the Servo Valve. The Servo Valve uses the differential pressures between the tank and the patient to calculate the flows.

10.3 Patient pressure section (0 to 110 mbar)

Once the gas leaves the Servo Valve it flows to the Ambient valve and the Patient High Pressure Valve. Then the gas flows past the inline O_2 sensor which measures the concentration of O_2 leaving the tank. The gas leaves the ventilator and goes to the patient via the patient tubing. The exhaled volume from the patient is measured by a variable orifice flow sensor. The expiration valve which is closed during inspiration allows the exhaled gas to escape during expiration and it also controls the level of PEEP in the patient circuit.

SECTION 10 PNEUMATIC OF THE AMADEUS

Used with marked Software Version

30 31 32 33

A E N O	Rev.						
	Aend-Nr						

Diese Zeichnung gilt als dem jeweiligen Inhaber persönlich anvertraut. Das Eigentum und das Urheberrecht verbleibt uns. Ohne unsere schriftliche Genehmigung dürfen die Zeichnungen weder kopiert noch Dritten zugänglich gemacht werden.

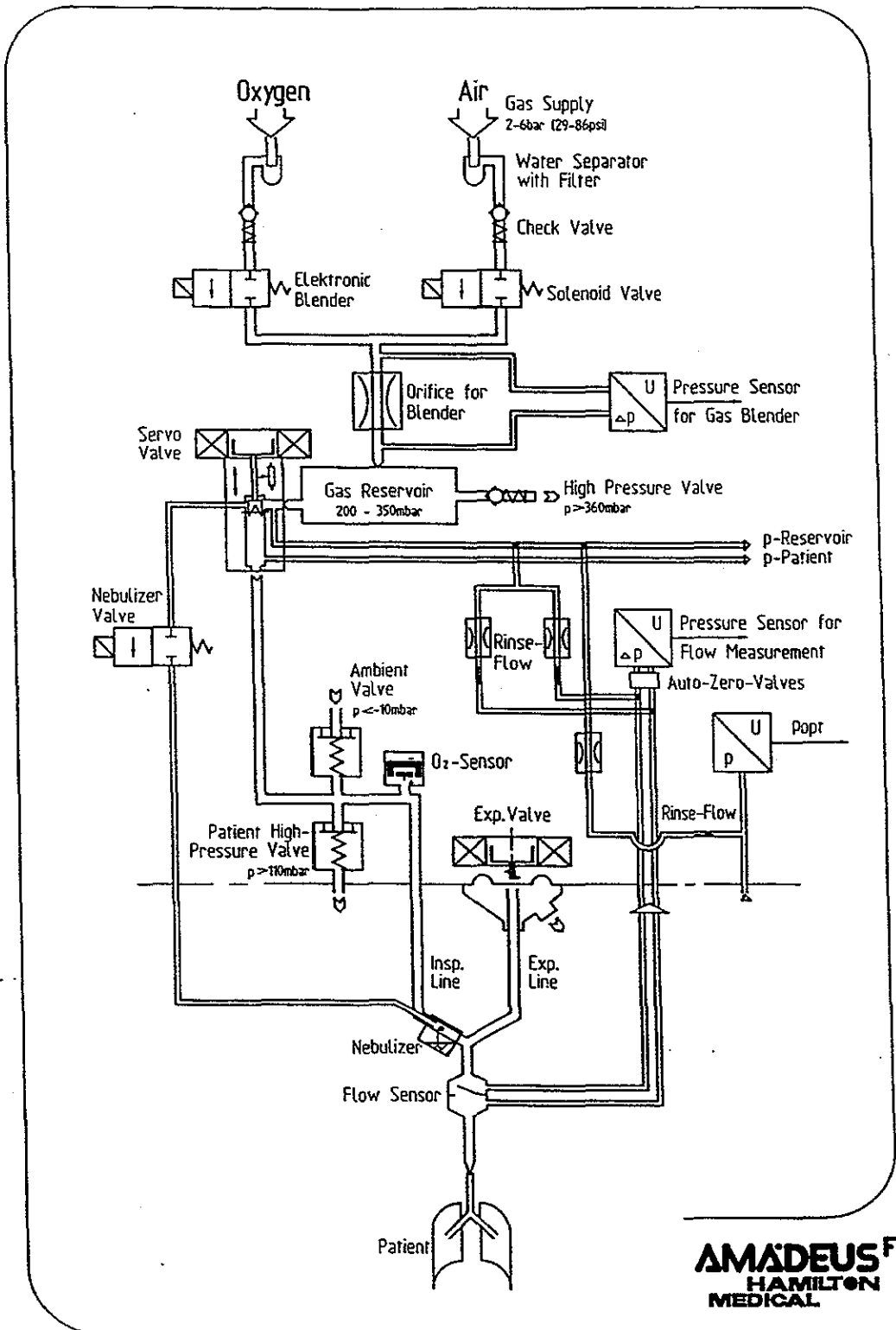


Fig. 1 AMADEUS (E) 1992-08-27 RO-BA 610316

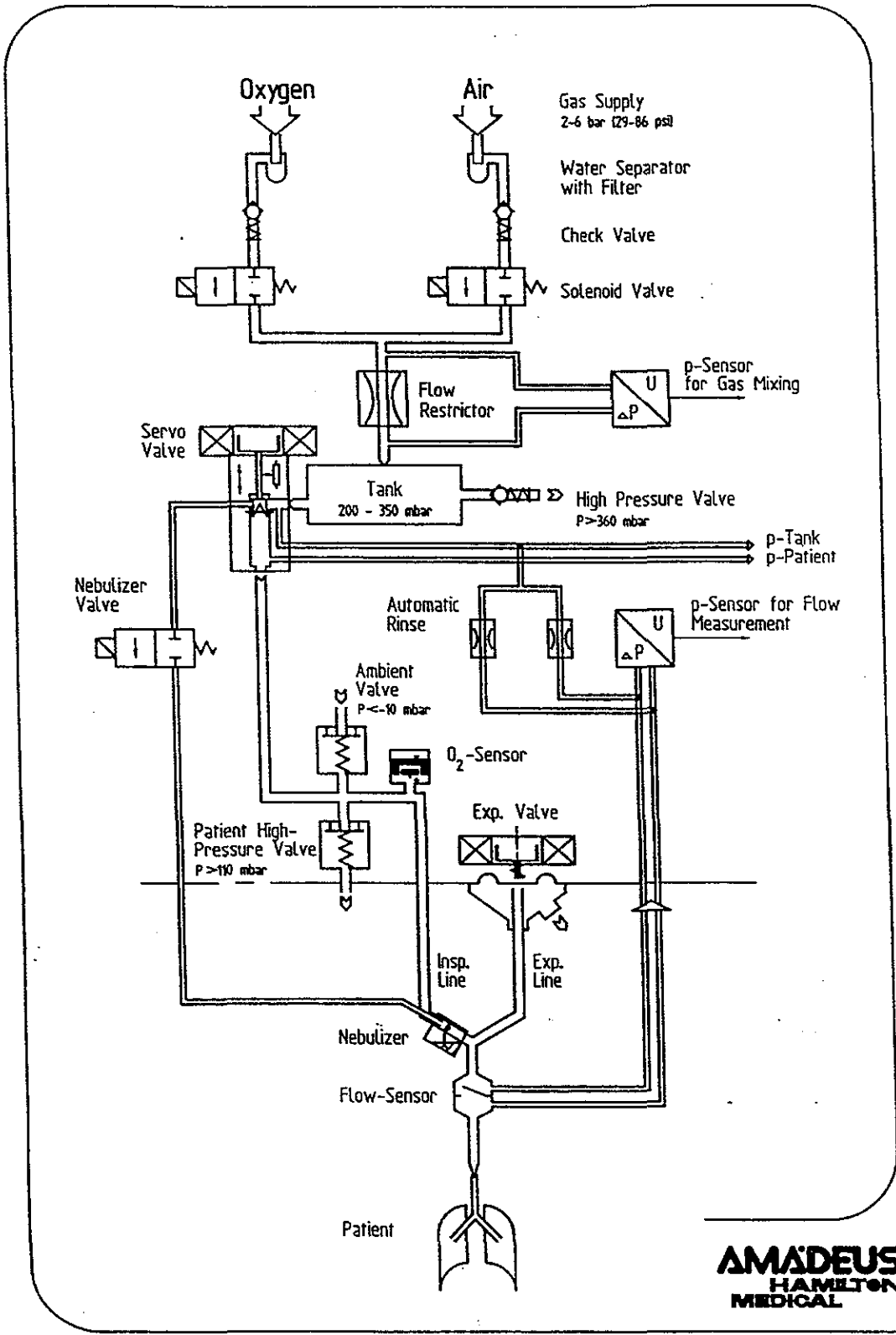
AMADEUS^{FT}
HAMILTON
MEDICAL

SECTION 10 PNEUMATIC OF THE AMADEUS

Used with marked Software Version			
30	31	32	33

A	Rev.								
E	Änd-Nr								
N	Datum								
D	Visum								

Diese Zeichnung gilt als dem jeweiligen Inhaber persönlich anvertraut. Das Eigentum und das Urheberrecht verbleibt uns. Ohne unsere schriftliche Genehmigung dürfen die Zeichnungen weder kopiert noch Dritten zugänglich gemacht werden.



610304

22. 2. 1994 4.09pm

10.4 Electronic mixing system

The electronic mixing system uses a microprocessor to control the mixing of gases and the regulation of tank pressure. The mixer consists of two solenoid valves, a pressure sensor and a pneumatic resistor. The operating principle of the mixer is that by measuring the pressure drop across the pneumatic resistor, a microprocessor calculates the length of time each solenoid valve needs to be activated to obtain the correct F_{O_2} and tank pressure.

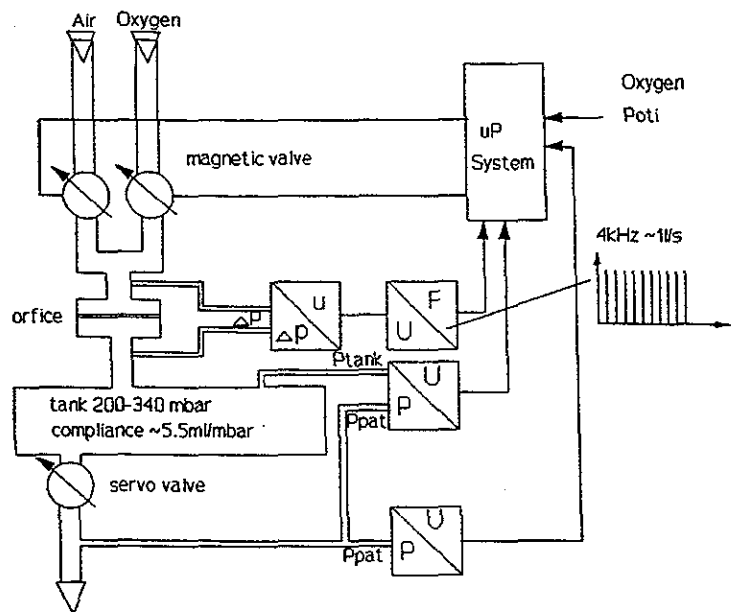


fig 10_1

$$1) V + p * C_{\text{tank}}$$

$$2) F_{O_2} = \frac{0.21 * V_{\text{Air}} + V_{O_2}}{V_{\text{tot}}}$$

$$3) V_{\text{tot}} = V = V_{\text{Air}} + V_{O_2}$$

10.5 Inspiratory Valve (Servo Valve)

The major working component in the AMADEUS is the Inspiratory Valve (Servo Valve) which delivers the required volumes to the patient. The three main parts of the Servo Valve are an electrodynamic motor, a plunger and a linear positioner. The electrodynamic motor is used to move the plunger up and down, and the linear positioner measures the movement of the plunger. The plunger is a triangular shaped orifice that is used to calculate the amount of flow entering the patient system. Knowing the height of the triangle and compensating for the pressure drop across the Servo Valve the microprocessor can determine precise inspiratory volumes for the patient.

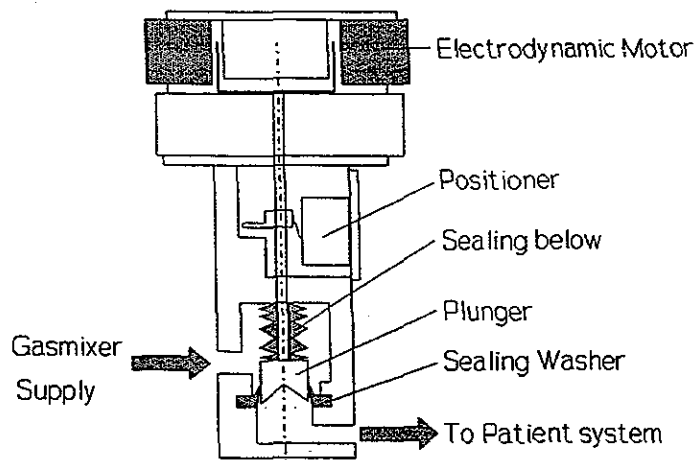


fig 10_2

10.6 Expiratory Valve

The Expiratory Valve assembly consists of three parts: the electrodynamic motor, the valve membrane and the valve cover. The design of the expiratory valve is shown in figure below. The Expiratory Valve works similarly to the Servo Valve, with the electrodynamic motor driving a plunger that applies pressure to the valve membrane. The Expiratory Valve has three different modes of operation:

1. Completely open - no pressure on the membrane from the plunger during expiration.
2. PEEP regulation - the plunger applies pressure to the membrane to keep the desired amount of pressure in the patient circuit.
3. Completely closed - maximum pressure on the membrane during inspiration and hold.

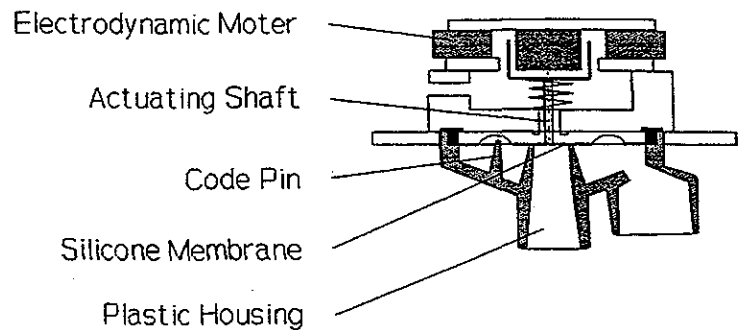


fig 10_3

10.7 Ambient/High Pressure Valve

The Ambient Valve provides the patient with the ability to breathe room air when the ventilator fails or the pressure in the patient circuit drops below -10 cm of H₂O. The High Pressure Valve is a safety valve that releases pressure in the patient circuit when the pressure exceeds 110 cm of H₂O.

10.8 Flow sensor

The AMADEUS measures the expiratory flows of the patient with a flow sensor. The flow sensor consists of a variable orifice. The patient flows are calculated, by measuring the pressure drop across the variable orifice.

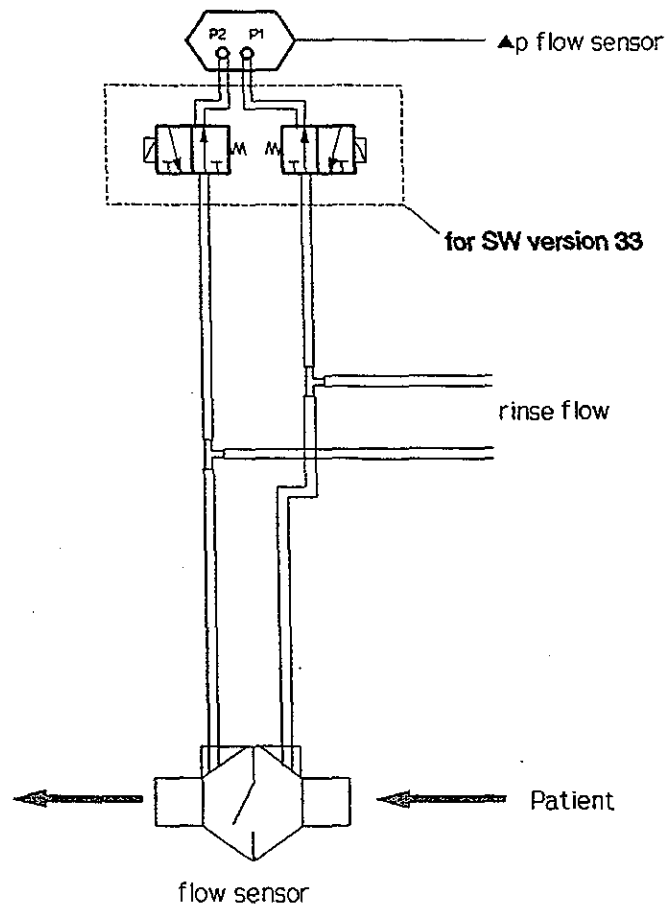


fig 10_4

The pressure sensor used for an accurate flow measurement is a very precise instrument and sensitive to different environmental conditions (e.g. temperature and humidity). To protect AMADEUS from external influences, the zeropoint of the flow sensor is automatically reset every 20 minutes. After switching AMADEUS on, this procedure takes place in short intervals (after 2, 5, 8, 11, 14, 17, 20 minutes and every 20 mins following the 20th minute). During this automatic resetting, which will last 0.75 seconds, the patient is ventilated according the set controls and parameters such as Exp. Tidal Volume, Resistance, Compliance and PEEP cannot be measured or monitored. For this reason, during this 0.75secs, the Patient Monitor pauses and displays the data of the last breath.

This pressure sensor is connected to the flow sensor via two tubes.

The flow sensor is highly accurate ($\pm 5\%$) and suitable for all volume ranges of pediatric and adult applications (20 to 2.000 ml). Calibration of the flow sensor carried ou by a microprocessor. The accuracy is only minimally affected by humidity or nebulized drugs (error of -0.1% at BTPS compared with STPD).

The main purpose of the flow sensor is to provide on-line data concerning volume, flow and timing for the Monitor and Alarm System. The flow sensor is not used to control the ventilator. In the event of a malfunction of the flow sensor system, ventilation of the patient is unaffected, but the measured values could be inaccurate and the "Flow Trigger"-mode may not be active (only the pressure-trigger will be active).

11	TESTSOFTWARE	2
	11.1 Contents of the Test description	2
	11.2 Important Note	3
	11.3 Warnings	3
	11.4 Maintenance	3
	11.5 Preparation	4
	TEST 1.0	8
	TEST 2.0	9
	TEST 3.0	10
	TEST 5.0	11
	TEST 6.1	12
	TEST 6.2	13
	TEST 7.0	15
	TEST 8.0	16
	TEST 10.0	17
	TEST 10.1	18
	TEST 11.0	19
	TEST 16.0	20
	TEST 16.0	21
	TEST 17.0	22
	TEST 18.0	23
	TEST 19.0	24
	TEST 20.0	25
	TEST 21.0	26
	TEST 22.0	29
	TEST 23.0	31
	TEST 24.0	33
	TEST 25.0	36
	TEST 26.0	37
	TEST 26.0	39
	TEST 27.0	40
	TEST 28.0	41
	TEST 29.0	43
	TEST 30.0	46
	TEST 31.0	47
	TEST 33.0	48
	TEST 36.0	49
	TEST 37.0	50
	TEST 38.0	52
	TEST 38.0	54
	TEST 39-47	56
	TEST 48	57

11 TESTSOFTWARE

11.1 Contents of the Test description

Preparation	
Test 1.0	Front Panel processor test
Test 2.0	Control Panel LED test
Test 3.0	Alarm Panel LED test
Test 5.0	Key test
Test 6.1	Monitor Selector test
Test 6.2	DIP switch test
Test 7.0	Display test
Test 8.0	Bargraph test
Test 10.0	Control Panel poti-test
Test 10.1	Control Panel poti-test
Test 11.0	Monitor Panel poti-test
Test 16.0	Voltage test
Test 17.0	Communication-test frontpanel-CP
Test 18.0	Communication-test CP-FP
Test 19.0	Communication-test FP-CP
Test 20.0	Status Error test (fail to cycle)
Test 21.0	12 Bit / 8 Channel ADC test
Test 22.0	8 and 12 Bit DAC test
Test 23.0	Ppat, Popt, delta P-servo
Test 24.0	Full scale adjust delta pressure (for SW version 33, also Ppat and Popt)
Test 25.0	Mixer test
Test 26.0	Nebulizer Valve test
Test 27.0	Servo valve mechanical tightness
Test 28.0	Technical Panel Tightness Tests
Test 29.0	Calibration Servo Valve
Test 30.0	Servo Valve Electrical Tightness
Test 31.0	Expiration Valve Test and PEEP
Test 33.0	End Control Test Interface
Test 36.0	Low Internal Pressure Alarm
Test 37.0	O ₂ Sensor Test, flow adjust
Test 38.0	Calibration Test
Test 39-47	Flow Measurement Test
Test 48	Tank Overpressure Valve Test
Functional tests	see Operator's Manual
Adjustment servo valve 500ml below 660mas	
Adjustment servo valve 500ml above 660mas	

11.2 Important Note

The following test instructions are only for service engineers who have already joined a training course with Hamilton Medical AG or one of its representatives. The instructions are in point form, so it may be necessary to make your own notes.

11.3 Warnings

Only use original Hamilton Medical spare parts for repairs.

Changes or repairs on the AMADEUS must be done only by HAMILTON MEDICAL authorized service technicians.

All used AMADEUS respirators are contaminated. There for, always clean the instrument with an antiseptic liquid before servicing or repairing it.

11.4 Maintenance

Service of the AMADEUS Ventilator must be carried out every year or after 5000 operating hours. During this service, the fan filter (279 166) and microfilters from the gas inlets (279 444) must be replaced. After this replacement, the instrument must be readjusted and calibrated according to the test instructions.

The AMADEUS includes a rechargeable battery. In addition, the optional Interface Board includes a lithium battery. HAMILTON MEDICAL AG recommends that these batteries be replaced 5 years after delivery. Please recycle the batteries or return them to HAMILTON MEDICAL AG.

11.5 Preparation

Disconnect all tubings and supplies (gas and electric) from the **AMADEUS**. Then, follow the instructions (written in bold) and check the results (written in normal font). If one of these results is incorrect or not in the allowed range, then rectify the cause of this deviation!

Before starting:

- No LED is illuminated
- The buzzer does not sound
- The fan does not turn

Turn on the instrument

- The buzzer sounds and the Power LED becomes illuminated.

Turn off the instrument and take off the enclosure. (The enclosure can be placed on the AMADEUS trolley.)

- All cables must be connected at the correct place. (see Drawing on page 1-5 for assistance).
- The 7 ground wires must be fixed correctly and should not be defective.
- All boards must be in place and must be locked. (The position of each board is written on the frame of the rack.)
- Each tube must be in order, locked and connected at the right place. (See Drawing on page 1-5.)
- The mechanical parts must be checked as they should all be fixed and in the correct place.
- The gas inlets must be checked-there should be no condensation in the water separator and the micro filters should be clean.

Note: On the left is the air inlet and on the right the O₂ inlet. (viewed from rear)

- The fan dust filter must be clean.

Remove the Rear Panel.

- The Rear Panel and the Enclosure must not be damaged!
- The ring of the Expiration Valve must turn easily and not be damaged.

Remove the Supervisor Board

- The settings of the DIP switches depend on the options selected. (see Section 13).
- The factory setting is: all switches at "OFF".

Replace the supervisor and remove the Frontpanel Processor board.

- DIP switch SW1 (S1-S8) is used for options (see section 13). The factory settings are: all at OFF.
- DIP switch SW2 (S1-S2) is used to select the size (and software version) of the E-PROM (yellow or white sticker).

(The white point on SW2 indicates the ON-position).

Factory settings:	SW2	
	S1	S2
AFP 33X.0	ON	ON
AFP 33F.0	ON	ON
AFP 33B.0	ON	ON
AFP 32S.2	ON	ON
AFP 32S.1	ON	ON
AFP 31S.1	ON	OFF
AFP 30S.1	ON	OFF

Note:

The Front Panel processor and the control processor board are identical, except for the EPROMs! To change the boards, do not forget to change the EPROM and the settings of SW1 and SW2!

Replace the Front Panel processor and remove the control processor board.

- The DIP switch SW1 is used for options (See Section 13).
Without options the factory settings is: S1 to S8 = OFF.
- SW2 (S1-S2) is to select the size (and software version) of the EPROM (yellow or white sticker).

(The white point on SW2 indicates the ON position).

Factory settings:	SW2	
	S1	S2
NCP 33A.5	ON	ON
NCP 32A.2	ON	OFF
NCP 32A.1	ON	OFF
NCP 31A.2	ON	OFF
NCP 30.12C	ON	OFF

Replace the control processor board and remove the Mixer, O₂ and Flow Board.

- The DIP switch SW1 can also be used for options. (See Section 13 for more information about options).

The adjustment for the elevation of the unit can be done with switches S1 and S2.

The factory setting is: EPROM versions RMI 0300, RMI 0301 and RMI33A.0

S1 = ON 900 meter above

S2 = OFF sea level

S3 = ON

S4 = OFF

S5 = OFF

S6 = OFF

S7 = OFF

S8 = OFF

Insert the Mixer, O₂ and Flow Board.

Connect the power supply cable and turn the instrument on.

- The fan blows the air into the AMADEUS.
- The voltage on the Mother Board (TP1, TP18) must be

$5V \pm 20 \text{ mV}$

This can be adjusted with potentiometer R10 on the voltage regulator board.

- The voltage on the Mother Board (TP17, TP15) has to be

$+15V \pm 0.7V$

and (TP16, TP15)

$-15V \pm 0.7V$

Turn the instrument off and set the switch S5 from SW1 on the Supervisor Board to 'ON' (Test software).

Turn the O₂ potentiometer (Control Panel) to 21%.

Now switch the AMADEUS on and turn the selector knob to the left.

- The display should show you "t 1.0" .
(If the monitor selector is now turned to the next position, the test number 1.0 will be activated .
- To select another test, turn the selector to "t 1.0" and choose with the button 'SIMV' a higher, with 'Assist Control' a lower test number. These tests can also be activated by turning the monitor selector to another position.

TEST 1.0Function:

Front Panel processor test.

Description:

To test the communication between the Front Panel processor and the power supply. In addition, the external RAM, the EPROM and the charge of the accumulator will be tested.

Method and Requirements:

Select Test 1.0 and turn the monitor selector to position 2.

- within 0.5 sec., the buzzer must sound and the power LED must illuminate. 1.5 must be displayed.

Troubleshooting:

If the display shows:

- 1.1 Accumulator test has failed
- 1.2 RAM enabled test has failed
- 1.3 RAM write test has failed
- 1.4 DATA save test has failed
- 1.5 Test is successful

TEST 2.0

Function:

Control Panel LED's test

Description:

Each LED on the control panel will illuminate individually one by one for 0.5 sec.

Method and Requirements:

Select the test 2 and activate it by turning the monitor selector to position 2.

- The LEDs on the control panel illuminate one by one for 0.5 sec. The sequence is shown in the following drawing.

Note: the drawing below shows the Control Panel of SW 33X.

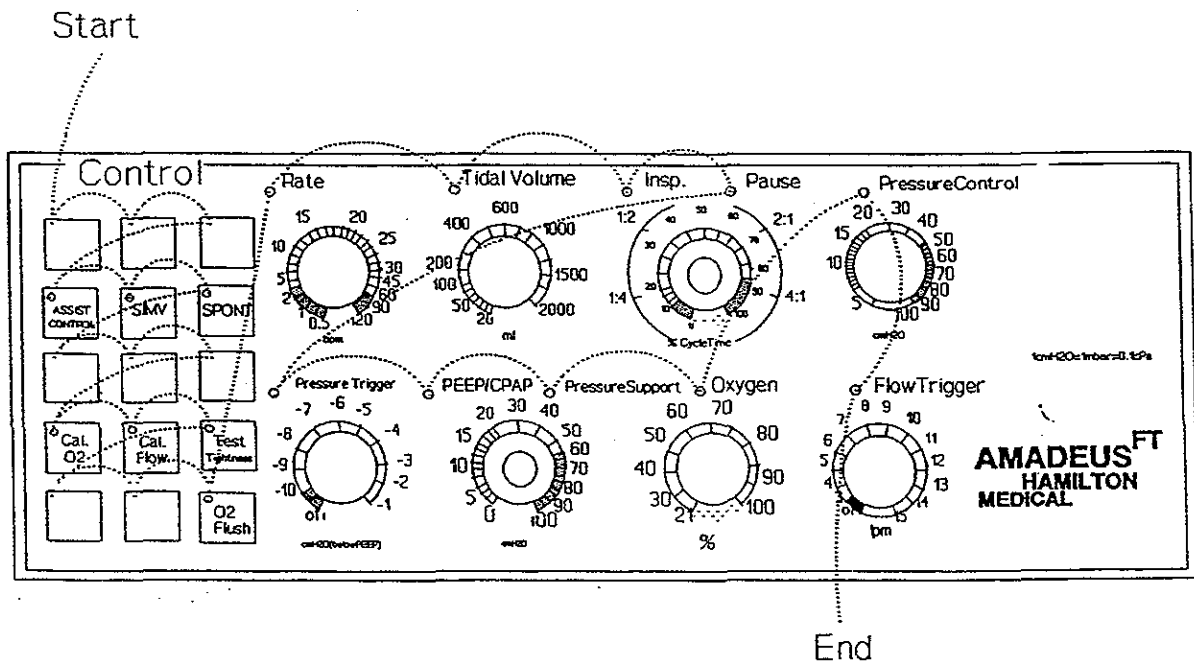


fig. 12.1

Troubleshooting:

TEST 3.0

Function:

Alarm Panel LED's test

Description:

Each LED on the alarm panel will illuminate one by one for 0.5 sec.

Method and Requirements:

Go to test 3.0 and turn the monitor selector to position 2.

- Now the LEDs will illuminate for 0.5 sec one by one.
(The sequence is as indicated in the following drawing).

Note: While the "Power" LED is ON, the buzzer must sound.

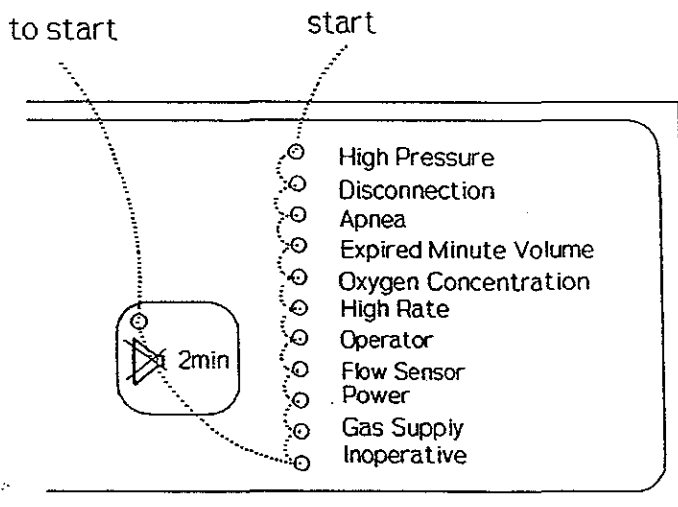


fig. t2_1

Troubleshooting:

TEST 5.0 (Note: Test 4.0 is not used)

Function:

Key test

Description:

All LED's illuminate. Pressing the corresponding key, puts out the LED. After each key has been pressed, the buzzer will sound.

Method and Requirements:

Activate the Test 5.0 by setting the monitor selector to position 2.

- All LEDs are illuminated

Press key by key to put out the LEDs

- While all keys have been pressed, the buzzer will sound.
(Note: Do not forget to press the optional keys.)

Troubleshooting:

TEST 6.1

Function:

Monitor Selector test

Description:

The display will show the numbers 1 to 9, which correspond with the position of the monitor selector.

Method and Requirements:

Monitor selector positions (Version 30):

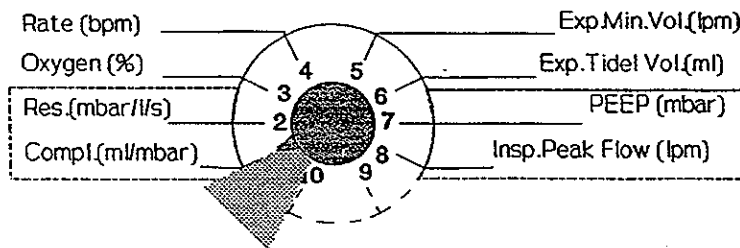


fig. 61_1

Modified monitor selector positions (Version 31,32,33):

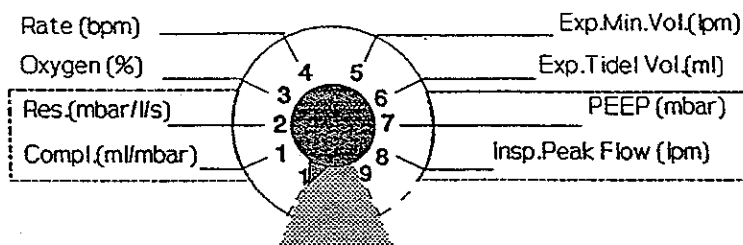


fig. 61_2

Select test 6.1

Now turn the monitor selector to position 2

- On the display, there should be: "1".

On position 3 —> "2"

```

:   :   :   :   :
:   :   :   :   :
:   :   :   :   :

```

On position 10 —> "9"

Troubleshooting:

TEST 6.2

Function:

DIP switch test

Description:

All 24 switches on the Supervisor Board will be tested in different monitor selector positions.

Method and Requirements:

Note the settings of all the switches, so that they can be reselected after completion of the test.

Activate Test 6.2 and set the monitor selector to position 2.

Check SW1 in position 2 of the monitor selector; check SW2 in position 3; check SW3 in position 4.

- The display shows "255" (8 bit).

Set the switches from SW1 to 'OFF'.

- 000 will be displayed.

The same procedure must be made with SW2 and SW3.
Do not forget to turn the monitor selector to position 3 for SW2 or position 4 for SW3.

All switches at 'ON' -> 255

All switches at 'OFF' -> 000

Now switch S5 from SW1 at 'ON'.

Note: Set the DIP switches to the original position. A list in section 13 describes the different switches. For SW Version 33 find the different Monitor Versions at the following page.

Troubleshooting:

Monitor Panel USA/GB

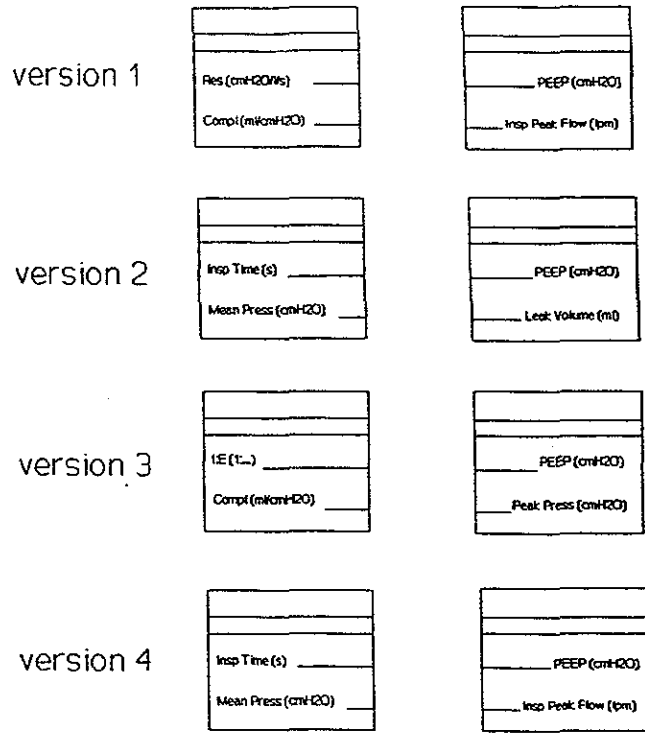


fig. 62_1

Activating your Monitor Version

Select the desired Monitor Panel version, using switches S20 and S21 on the Supervisor Board.

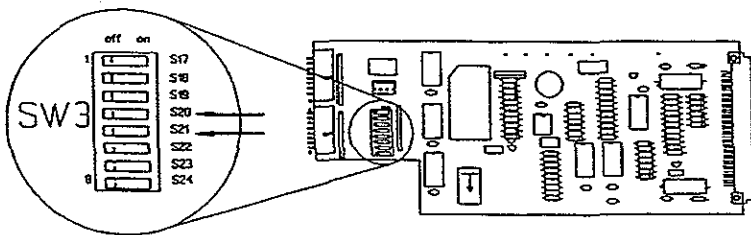
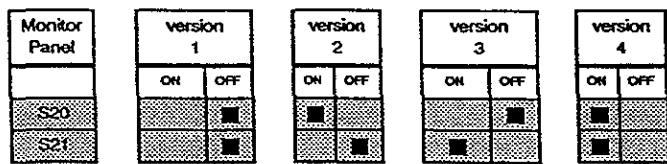


fig. 62_2

TEST 7.0**Function:**

Display test

Description:

Each segment of the display will be tested from numbers 1 up to 9 (in that order).

Method and Requirements:

Select test 7.0 and set the monitor selector to position 2.

- The numbers 1, 2, 3, 4, 5, 6, 7, 8, 9 and the "." move from right to left through the display.

Troubleshooting:

TEST 8.0**Function:**

Bargraph test

Description:

To check each segment of the bargraph.

Method and Requirements:

Go to test 8.0 and select position 2 with the monitor selector.

- Starting from zero, the bargraph display will build up to max. pressure, then down to zero and further to minus 10. Then display builds up again.

- Note:
- The zero segment is always illuminated.
 - When the bargraph reaches the max. pressure the Trigger LED will flash.

Troubleshooting:

TEST 10.0 (Note: Test 9 not used)**Function:**

Control Panel potentiometer test

Description:

The measured value of each potentiometer will show on the display as a number between 0 and 255. (8 bit)

Method and Requirement:

Go to test 10.0

The following table contains the corresponding positions of the monitor selector and the potentiometer. The adjusting values are also given.

Note: The potentiometer-LED's show which potentiometer is selected

Turn the potetiometer from 0 to 255 to check the range.

Monitor Selector	Potentiometer	Value	Display	Adjusting Value
1			t 10.0	
2	Rate	0.5 18 120	0-20 129-132 253-255	130-131
3	Tidal Volume	20 600 2000	0-2 126-129 253-255	127-128
4	Insp.	0 50 100	0-2 126-129 253-255	127-128
5	Pause	0 50 100	0-2 126-129 253-255	127-128
6	Trigger	OFF - 6 - 1	0-2 126-129 253-255	127-128
7	PEEP/CPAP	0 10 100	0-2 56-58 253-255	56-58
8	P Support	0 25 100	0-2 126-129 253-255	127-128
9	Oxygen	21 60 100	0-2 124-127 253-255	125-126

Note:
While turning the potentiometer from the very left stop to the very right stop, the displayed value must count without breakouts and jumps.

Troubleshooting:

TEST 10.1

Function:

Control Panel potentiometer test.

Description:

The measured values of the 'PCV' and 'Flow Trigger' potentiometers will show on the display as numbers between 0 and 255 (8Bit).

Method and Requirements:

Go to test 10.1

The following table contains the corresponding positions of the monitor selector and the potentiometer. The adjusting values are also given.

Turn the potetiometer from 0 to 255 to check the range.

Monitor Selector	Potentiometer	Value	Display	Adjusting value
1			1 10.1	
2	PCV	0 25 100	0-2 126-129 253-255	127-128
3	Flow Trigger	0 8 15	0-2 130-133 253-255	131-132

Note:
While turning the potentiometer from the very left stop to the very right stop, the displayed value must count without breakouts and jumps.

Troubleshooting:

TEST 11.0

Function:

Monitor Panel potentiometer test

Description:

The measured value of each potentiometer will show in the display as a number between 0 and 255 (8 bit).

Method and Requirement:

Go to test 11.0

The following table contains the corresponding positions of the monitor selector and the potentiometer. The adjusting values are also given.

Remark: The alarm-LED's show which potentiometer is selected.

Turn the potentiometer from 0 to 255 to check the range.

Monitor Selector	Potentiometer	Value	Display	Adjusting Value
2	High Rate	20 70 130	0-20 114-118 253-255	116
3	High Pressure	10 60 110	0-2 126-129 253-255	127-128
4	Exp.Min.Vol.'LOW'	0.2 10 50	0-2 124-126 253-255	125
5	Exp.Min.Vol.'HIGH'	0.2 10 50	0-2 124-126 253-255	125
6	Oxygen Limits	OFF min 50 100	0-2 119-121 253-255	120

Note:

While turning the potentiometer from the very left stop to the very right stop, the displayed value must count without breakouts and jumps.

Troubleshooting:

TEST 16.0**Function:**

Voltage test

Description:

The supply voltages and the reference voltages from the AD converters will be displayed. The temperature of the Monitor and Control Panel can also be checked.

Method and Requirements:

Select Test 16.0 and choose position 2 with the monitor selector.

- Now the displayed value must be in the allowed range. The range and the corresponding voltage or temperature are shown in the table below.

Go through all selector positions and check the displayed values.

Monitor Selector	Voltage	Display
2	15 Volt	115-145
3	± 15 Volt	51-219
4	Temp. Monitor Panel	Roomtemp. * 10
5	Temp. Control Panel	Roomtemp. * 10
6	V-Ref. Monitor Pot.	125-130
7	V-Ref. Control Pot.	125-130
8	V-Ref. Option Pot.	125-130

Troubleshooting:

TEST 16.0

Function:

Voltage test

Description:

The supply voltages and the reference voltages from the AD converters will be displayed. The temperature of the Monitor and Control Panel can also be checked.

Method and Requirements:

Select Test 16.0 and set position 2 with the monitor selector.

- Now the displayed value must be in the allowed range. The range and the corresponding voltage or temperature are shown in the table below.

Go through all selector positions and check the displayed values.

Monitor Selector	Voltage	Display
2	15 Volt	115-145
3	± 15 Volt	51-219
4	Temp. Monitor Panel (T_M)	Roomtemp * 10 $\pm 10\%$
5	Temp. Control Panel (T_C)	Roomtemp * 10 $\pm 10\%$
6	V-Ref. Monitor Pot.	125-130
7	V-Ref. Control Pot.	125-130
8	V-Ref. Option Pot.	125-130
9	Temp. Monitor Panel selfheated (T_J)	> 350

Troubleshooting:

SECTION 11	TESTSOFTWARE	Used with marked Software Version				
		30	31	32	33	

TEST 17.0

Function:

Communication test between Front Panel and Control Processor.

Description:

The Front Panel Processor sends the numbers 1..12 to the control processor. This processor sends the information back and the frontpanel processor displays the received information.

Method and Requirements:

Select position 2 in test 17.0

- The display counts up from 1 to 12 and starts again.

Troubleshooting:

TEST 18.0

Function:

Communication test between control and Front Panel Processor.

Description:

The control processor simulates a communication error. Then the Front Panel Processor must detect this error and must give a power alarm.

Method and Requirements:

Select test 18.0 and go to position 2 with the monitor selector.

- After 1 sec. the power alarm must occur. (Buzzer and LED)

Troubleshooting:

TEST 19.0**Function:**

Communication test between control and Front Panel Processor.

Description:

The Front Panel Processor simulates a communication error. Then the Control Processor must detect this error and must give a Power alarm.

Method and Requirements:

Select test 19.0 and position 2 with the monitor selector.

- After 1 sec the Power alarm must occur. (Buzzer and LED)

Troubleshooting:

TEST 20.0**Function:**

Status error test (Fail to cycle)

Description:

The Control Processor simulates a status error. This error must be detected by the Front Panel Processor. Before the alarm is given, there is a delay of:

25 sec (for SW version 30)

30 sec (for SW version 31,32 and 33)

Note: After reinstalling the Supervisor Board the ventilator must run in normal function first before in Test Software Mode.

Method and Requirements:

Select Test 20.0 and position 2 with the monitor selector.

- After 25 sec./30 sec., the disfunction alarm must occur. The "Disfunction" LED blinks.

Troubleshooting:

TEST 21.0

Function:

12 Bit/8 Channel ADC Test of the Analog I/O Board.

Description:

This test checks the analog signals that are sent through the 8-channel multiplexer into the ADC converter. The test utilizes a testbox which regulates the input voltage to each channel of the multiplexer.

Instruments:

The analog I/O testbox (500 350) needs to be connected for Test software test 21-22.

Method and Requirements:

Turn off the power of the ventilator.

Disconnect the flat cable from the Analog I/O board (connector P2) and connect the flat cable from the I/O testbox. The red cable from the box must be connected on TP17 (Motherboard) and the black cable on TP16 (Motherboard).

Turn the power on.

Go to Test 21.0 and turn the monitor selector to position 2.

Select positive polarity on the testbox (+10V) and set U_{in} (ADC) to 10 volts by adjusting the potentiometer to 10.0V. Set all switches S1-S8 to GND.

- The display should read $0V \pm 15mV$.

This voltage can be readjusted by using the Zero Adjust potentiometer (R1) on the Analog I/O board.

For each test turn on the specified switch.

- The displayed value for each switch should read 10.00V.
Check that the position of the monitor selector matches the corresponding position of the testbox switch, as indicated in this table.

Monitor Selector	Testbox		Display
	U_M (Volt)	Switch ON	
2	10	1	10 ±10mV
3	10	2	10 ±10mV
4	10	3	10 ±10mV
5	10	4	10 ±10mV
6	10	5	10 ±10mV
7	10	6	10 ±10mV
8	10	7	10 ±10mV
9	10	8	10 ±10mV

Reset U_{in} (ADC) to 9.0 volts and change the voltage polarity switch to (-10V). Check each line from Monitor Selector position 2 to 9 by turning on the corresponding switches.

Monitor Selector	Testbox		Display
	U_N (Volt)	Switch ON	
2	-9	1	-9 \pm 20mV
3	-9	2	-9 \pm 10mV
4	-9	3	-9 \pm 20mV
5	-9	4	-9 \pm 10mV
6	-9	5	-9 \pm 20mV
7	-9	6	-9 \pm 10mV
8	-9	7	-9 \pm 20mV
9	-9	8	-9 \pm 10mV

- Leave the test box in place for Test software 22.

Troubleshooting:

TEST 22.0

Function:

8 and 12 Bit DAC Test of the analog I/O Board.

Description:

This test checks the analog signals (U_{DA} Exp and U_{DA} Servo) from the 8 and 12 bit DA converters located on the analog I/O board.

Method and Requirements:

- U_{DA} -Exp is the 8 bit DAC signal and U_{DA} -Servo is the 12 bit DAC signal. The test box has separate parts for each signal. The requirements for the voltmeter read outs are as follows:

Testbox		
U_{IN} (Volt)	Switch S1	Measured Voltage
		U_{DA} Servo
+10	GND	0V \pm 20mV
+10	ON	+10V \pm 100mV
+7.5	ON	+7.5V \pm 75mV
+5.0	ON	+5V \pm 50mV
+2.5	ON	+2.5V \pm 50mV
+0.9	ON	+0.9V \pm 20mV

Testbox		
U_{IN} (Volt)	Switch S1	Measured Voltage
		U_{DA} Exp
+2.5	GND	0V \pm 20mV
+2.5	ON	+2.5V \pm 60mV
+5.0	ON	+5V \pm 60mV

- The voltage between TP18 (Flow Control board) and TP15 (Motherboard) has to be $+10V \pm 20mV$.
- The voltage between TP17 (Flow Control board) and TP15 (Motherboard) should measure $-10V \pm 20mV$.

Turn ventilator OFF

Disconnect the Analog I/O testbox

Reconnect the cable to the Analog I/O board

Turn ventilator ON

Troubleshooting:

TEST 23.0Function:

Pressure sensor test (optional pressure sensor)

Description:

This test checks the zero point setting of the patient pressure and the delta pressure sensor for the servo and for the mixer. (Also the zero point setting of the optional pressure sensor).

Method and Requirements:

Go to test 23.0 and select position 2.
(P-Patient)

The display must show you "0.0" .

If not, adjust the value with potentiometer "P_{pat}-Zero" (R51) on the Pressure Control Board. The voltage between TP16 (Pressure Control Board) and TP15 (Motherboard) should to measure "0" ± 15mV.

Turn the monitor selector to position 4.
(delta P-Servo)

The display shows "0.0" .

If not, adjust the value with potentiometer R23 on the motherboard. Between TP3 and TP15 (Motherboard) you have to measure 1.25 ± 40mV.

Troubleshooting:

Disconnect the red marked tubing from the tank. (part of the delta P-Mixer U6)

Now measure $0V \pm 5mV$ between TP25 (Motherboard) and TP15 (Motherboard). This can be adjusted with «zero Mixer» (R9) on the Motherboard.

Reconnect the red tubing to the tank.

Turn the monitor selector to position 3.
(Optional Pressure Sensor)

The display must show "0.0" .

If not, adjust with potentiometer "P_{opt}-Zero" (R50) on the Pressure Control Board. The voltage between TP15 (Pressure Control Board) and TP15 (Motherboard) should measure $0 \pm 15mV$.

Troubleshooting:

TEST 24.0

Function:

Full scale adjustment for the pressure sensor P-servo
(for SW version 33 , P-Servo, P-pat and P-opt).

Description:

The pressure sensor for the servo valve must be adjusted to full-scale.

Method and Requirements:

Adjust the Pressure Controller Display at "0-2 bar" without tubings connected to zero.

Connect the pressure controller as shown.

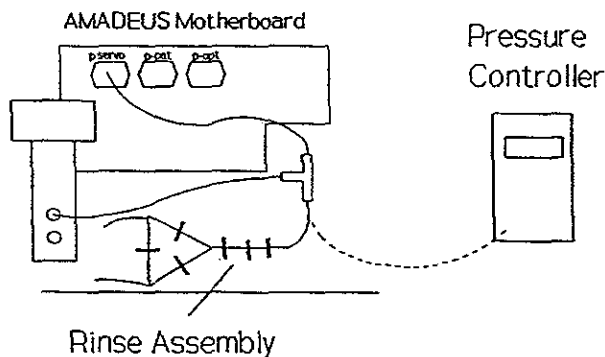


fig. 24_1

If the Flow Control Board or Servo Valve was changed, turn the potentiometer "20ml/s" R49 on the Flow Control Board anticlockwise to the very end. Otherwise continue below:

Connect the ventilator to air and oxygen.

Go to test 24 and select position 4.

(p servo)

- The display must show the same value as the pressure controller **± 2mbar** ! To adjust this value, use potentiometer R21 (p full scale) on the Motherboard.

Disconnect the pressure controller for Version 31 and previous versions.

TEST 24.0 (Cont'd)

Note: For SW 33 only!

Disconnect the tubes of the p-pat and p-opt.

Connect the pressure controller as shown in the following drawing.

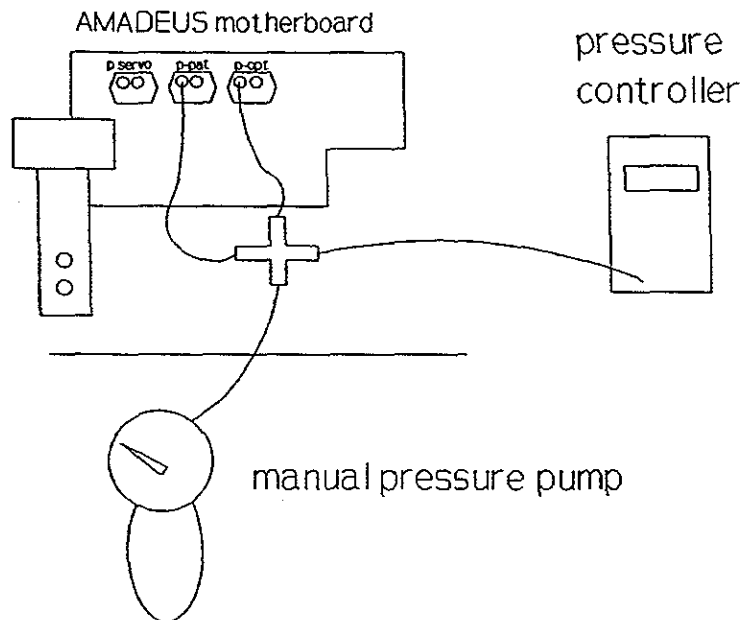


Fig. 24_2

Turn the monitor selector to position 2 for full scale adjustment of p-pat

Using the manual pressure pump, generate a pressure reading of 100 mbar on the pressure controller
The display must show the same value as the pressure controller $\pm 3\text{mbar}$.

Adjustment with potentiometer "Ppat Gain".
(Pressure Control Board)

Turn the monitor selector to position 5 for full scale adjustment of (p-opt)

The display must show the same value as the Pressure Controller.

Adjustment with potentiometer "Popt Gain".
(Pressure Control Board)

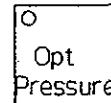
Disconnect the pressure controller and reconnect the p-pat and p-opt tubes to the pressure sensors.

TEST 24.0 (Cont'd)

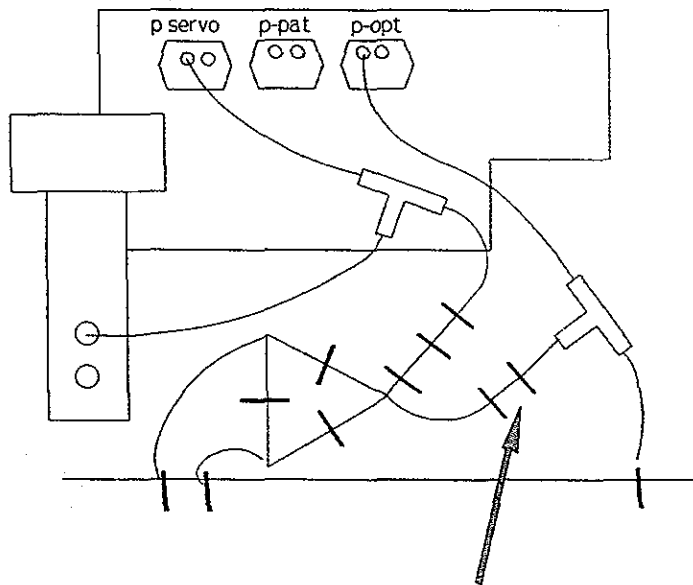
Check the optional tubings with monitor selector position 5.

Note: use this test only if a rinse flow is connected to the optional pressure tube (see drawing).

The key on the Control Panel for SW version 33:



AMADEUS motherboard



rinse flow for optional pressure tube

fig. t24_4

The display must show "0" as adjusted in Test 23 earlier.

Close the optional pressure connector with your finger.

The display must show > "12" mbar.

Troubleshooting:

TEST 25.0

Function:

Mixer test

Description:

This test is to adjust the tank peak pressure.

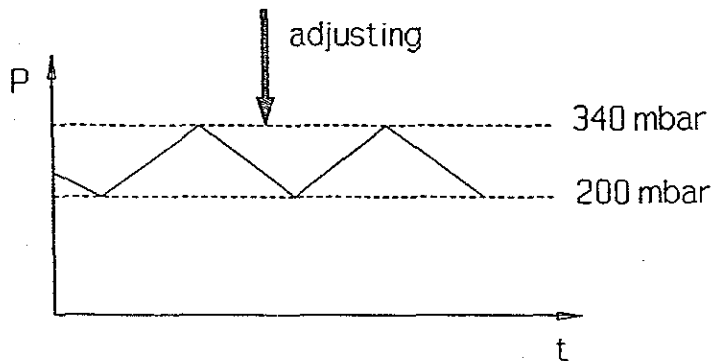


fig. t25_1

Method and Requirements:

Connect the ventilator to air and oxygen.

Go to test 25.0 and select position 3 with the monitor selector.

Turn the potentiometer "Gain Mixer" (R10) fully-anticlockwise.

- Wait until there is a value on the display.

Now adjust the tank peak pressure to "340" +0/+5 mbar, using the potentiometer "Gain Mixer" (R10) on the motherboard

Note: the tank pressure reading resets before each new tank filling.

Troubleshooting:

SECTION 11	TESTSOFTWARE	Used with marked Software Version				
		30	31	32	33	

empty page

TEST 26.0

Function:

Nebulizer Valve (Option) and
Auto Zero Assembly.

Description:

The nebulizer and the autozero valves are alternately, for work period of 10 seconds (5 sec. nebulizer and 5 sec. autozero valve).

Method and Requirements:

Connect the pressure controller to the nebulizer outlet.

Go to test 26.0

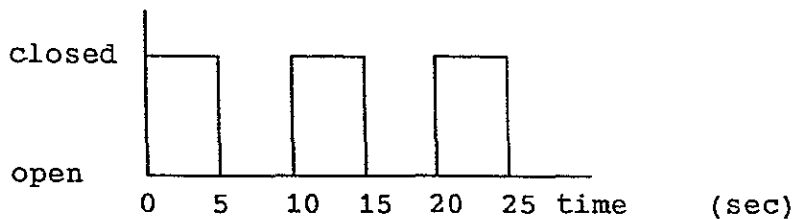
Nebulizer valve:

Select position 2.

The display must show 200 - 350 (pTank).

The measured voltage between TP6 and TP12 (servo power board) oscillates with a frequency of 0.1 Hz. The signal should look as follows:

Nebulizer valve TP6 (-15V +/-1V)
 TP12 (PWR GND)



Auto Zero assembly:

Select position 5:

If one of the flow sensor connectors is closed with your finger the display must show alternately "No-load voltage" and "corresponding voltage". (See below)

- "proximal" flow sensor connector closed :

"no-load" voltage
0V \pm 4V

"proximal side" voltage
-9.00... -9.99V

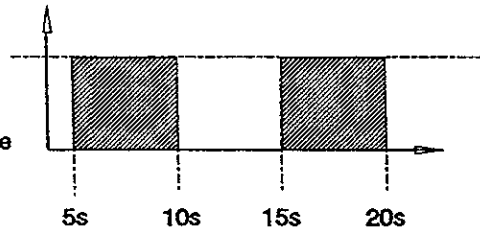


fig. t26_1

- "ventilator side" flow sensor connector closed :

"ventilator side" voltage
+9.00... +9.99V

"no-load" voltage
0V \pm 4V

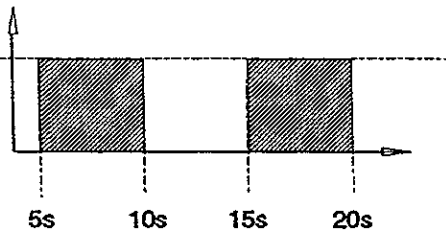


fig. t26_2

Troubleshooting:

TEST 26.0

Function:

Nebulizer valve (Option)

Description:

The nebulizer valve opens and closes alternately, for periods of 10 seconds (5 sec. open and 5 sec. close).

Method and Requirements:

Connect the pressure controller to the nebulizer outlet.

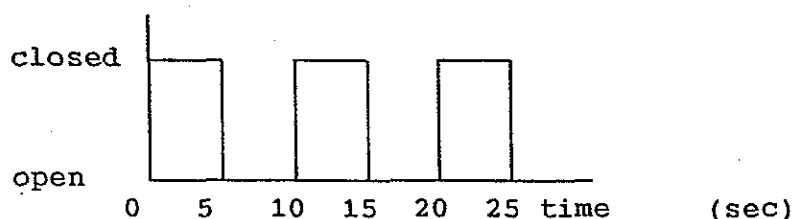
Go to test 26.0

Select position 2.

The display must show 200 - 350 (pTank).

The measured voltage between TP6 and TP12 (servo power board) oscillates with a frequency of 0.1 Hz. The signal should look as follows:

Nebulizer valve TP6 (-15V +/-1V)
 TP12 (PWR GND)

Troubleshooting:

TEST 27.0**Function:**

Servo Valve mechanical tightness test

Description:

This test closes the servo valve and checks for leaks.

Method and Requirements:

Go to test 27.0 and select position 2.

Use the Pressure Controller at 0 - 200 mbar and adjust it to zero.

Connect the capillary tube (20 ml/s) to the ventilator outlet.

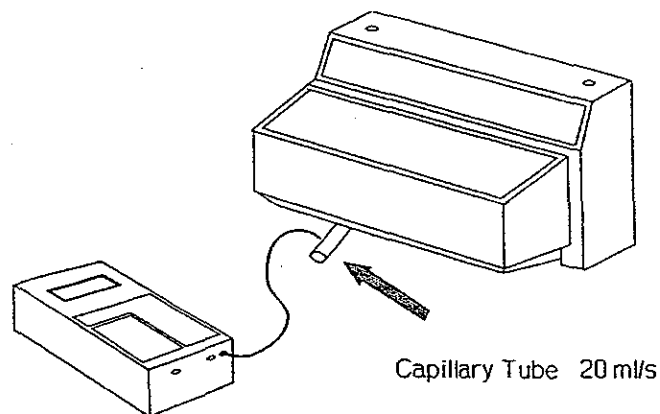


fig. 27_1

- The display shows the patient pressure. It must be less than 2.7 mbar. The measurement with the pressure controller should also be less than 2.7 mbar. Between TP15 (Flow Control board) and TP12 (Flow Control Board), the voltage must be less than 2.4V.

Troubleshooting:

TEST 28.0

Function:

Technical panel tightness test, patient overpressure and ambient valve test.

Description:

This test checks the tightness of the technical release of the patient overpressure valve. The performance of the ambient valve is also tested.

Method and Requirements:

Select test 28.0 and activate it by turning the monitor selector to position 2.

Connect the tubing system as shown.

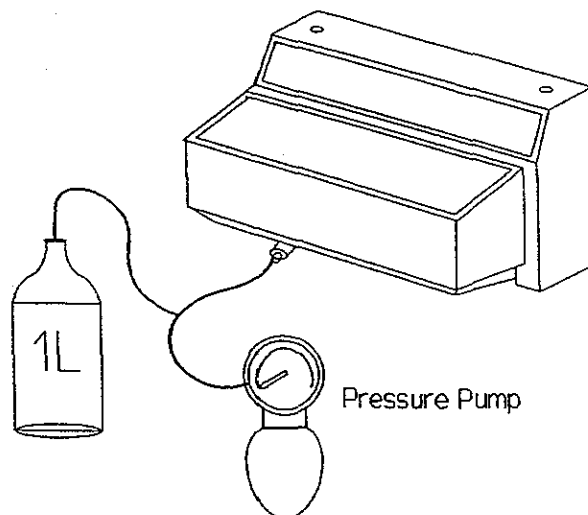


fig. t28_1

With the manual pressure generate a pressure reading of 100 mbar on the pressure controller.

- The time between the pressure decrease from 90 to 65 mbar must be **greater than 20 sec.**
(If increasing from 90 to 100mbar, also greater than 20 sec).

Turn the monitor selector to position 5.

Slowly make a patient overpressure (>110 mbar) with the hand pump.

- The display shows you the peak pressure of the patient overpressure valve. It must be at 110 ± 5 mbar.

Disconnect all tubing and connect the filter as shown.

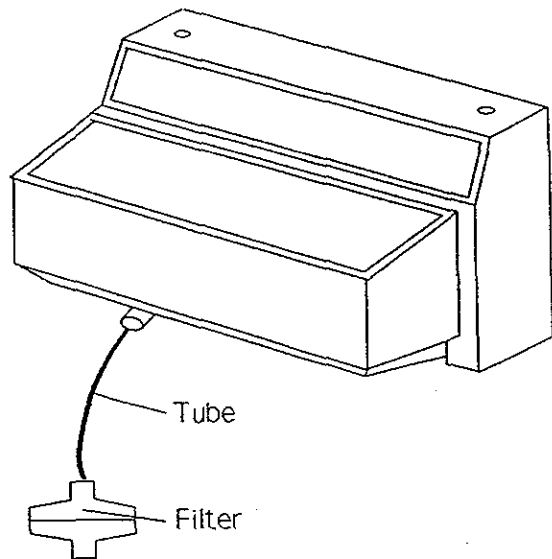


fig. t28_2

Select position 6

Generate an underpressure slowly by breathing through the filter to check the ambient valve.

- The display will show you the peak pressure. It has to be - $10 \text{ mbar} \pm 2 \text{ mbar}$.

Disconnect the tubing and the filter.

Troubleshooting:

SERVO VALVE CALIBRATION TEST

Function:

Calibration of the Servo Valve.
Measurement of a leakage from the tank overpressure valve.

Description:

This test calibrates the Servo Valve at flows of 20 ml/s and 500 ml/s at the unit's elevation. Test No's. 39, 40 and 44 are used to adjust the Servo Valve, not Test 29 as previously (to avoid hysteresis). Proceed with Test 30 after Servo Valve Calibration is finished. It also checks the tank overpressure valve for leakage.

Instrument:

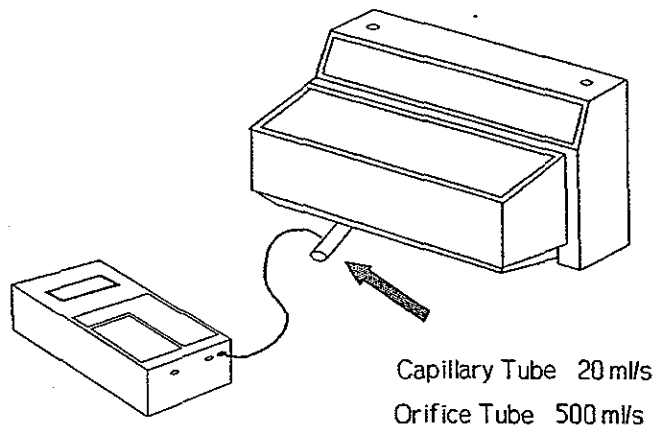


fig. t29_1

Method and Requirements:

- This test allows the Servo Valve to be calibrated at the elevation of the unit. In order to accomplish this, the nominal pressure engraved on the 500 ml/s orifice must be corrected for the elevation of the unit. This value is shown in the table at the end of these instructions. No correction is needed for the 20 ml/s capillary. The volume of flow can be adjusted by using the potentiometers located on the Flow Control Board.
- The volume of flow can be adjusted by using the pots on the Flow Control Board. Different flows are selected by using Test 40 and 44.

Go to test 39.0 and turn the monitor selector to position 2.
(Activates Servo to proper position)

Turn the O₂ concentration to 21 %.

Set the pressure controller to 0-200 mbar and adjust the zero point.

NOTE : To avoid hysteresis, always adjust the pressure from a lower pressure to the pressure printed on the capillary or on the orifice.

NOTE : The gas mixer is influencing the pressure variation in calibration.

After adjusting the pressure at the Test 40, always select Test 39 and return to Test 40 to check the pressure.
Then adjusting the pressure at the Test 44, always select Test 43 and return to Test 44 to check the pressure.

Go to test 40 and turn the monitor selector to position 2.

- 1) Connect the 20 ml/s capillary tube and adjust the 20 ml/s potentiometer (R49) on the Flow Control Board until the pressure controller reads within ~~±3 mbar~~ of the corrected nominal pressure printed on the orifice.
- 2) Connect the 500 ml/s orifice tube and go to test 44 and turn the monitor selector to position 2 (500 ml/s flow). Adjust the 500 ml/s potentiometer (R50) on the Flow Control Board until the Pressure Controller reads within ~~±2 mbar~~ of the nominal pressure printed on the orifice.
- 3) Repeat parts 1 and 2 until the pressure controller reads the nominal pressure for each flow.

- On the display, will be a value between ~~355 - 435~~ at 20 ml/s and a value between ~~1.93 - 2.15~~ at 500 ml/s .

Remove the test equipment and the sound absorber from the tank overpressure valve. (Golden plate).

Connect the adapter for the tank overpressure valve and fix the 20 ml/s capillary to the adapter.

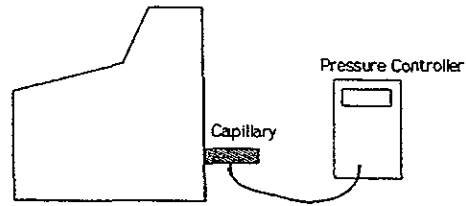


fig. 129_2

- The measured pressure on the capillary must be less than 2.5 mbar (2.5 mbar approx. 1 ml/s leak).

Disconnect the adapter and connect the sound absorber.

Troubleshooting:

TEST 30.0

Function:

Servo Valve electrical tightness test

Description:

This test electronically closes the Servo Valve and checks the leak.

Method and Requirements:

Go to test 30.0 and select position 3.

Connect the capillary tube (20 ml/s) to the ventilator outlet.

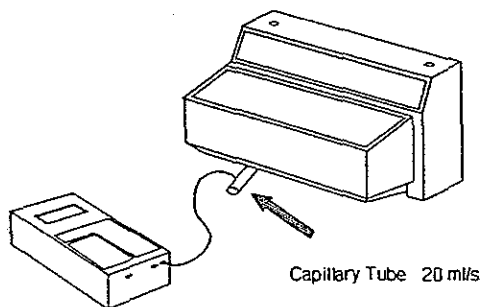


fig. 130_1

- The pressure controller must show you a pressure less than 2.5 mbar (2.5 mbar ~ 2 ml/s leak).
- The display shows a value between ~~400~~ and ~~550~~ mV. (TP13 on PC Board).

Disconnect the capillary

Troubleshooting:

TEST 31.0

Function:

Expiration Valve test and PEEP test

Description:

The Servo Valve generates a constant flow of 100 ml/s. This flow can be used to adjust the PEEP on the Expiration valve.

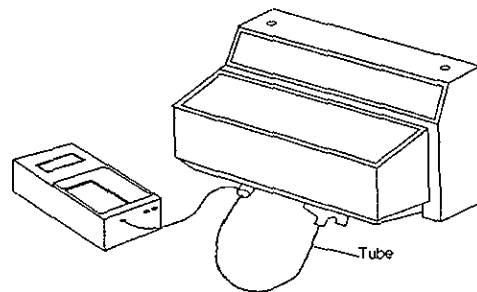
Instrument:

fig. 131_1

Method and Requirements:

Set the High Pressure Alarm Potentiometer to 110 mbar, so the pressure will not drop.

Go to test 31.0 and select position 2.

Turn the PEEP button to 10 mbar and adjust the pressure to 10 mbar with R49 (PEEP Adjust) on the Pressure Control Board. (Measured on the pressure controller). Now check the values on 20 mbar (± 2 mbar) and 30 mbar (± 3 mbar) PEEP.

Turn the PEEP button to 0 mbar.

- The voltage between TP12 on Pressure Control board and TP15 on Motherboard must be $0V \pm 0.1V$.

Disconnect all tubings.

Troubleshooting:

TEST 33.0 (Test 32 not used)

Function:

End control test interface (optional)

Description:

The interface sends a page 'U' to the connected printer.

Method and Requirements:

Connect the printer to the interface.

Go to test 33.0 and select position 3.

Press the two bottom left keys at the same time for at least 2 seconds and the printer starts to print 30 lines with 80 'U's each.

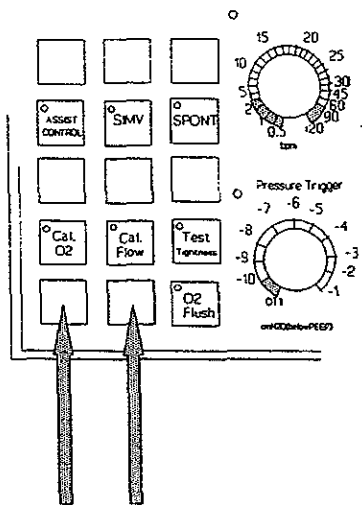


fig. I33_1

Note:

After exchanging the battery on the interface, the date, the time and the nominal output settings of the interface must be re-programmed. Otherwise the interface may not work properly.

Troubleshooting:

TEST 36.0 (Test 34, 35 not used)**Function:**

Low internal pressure alarm test

Description:

This test checks the low internal pressure alarm by having the Servo Valve generate a flow of 3 l/sec, so that the tank pressure will fall below 150 mbar. This activates the low internal pressure alarm.

Method and Requirements:

Disconnect all tubings from the inspiration line.

Go to test 36.0 and select position 3.

- A large flow of 3 l/sec is coming from the Servo Valve. The 'Inoperative' LED blinks and the display shows 4,75...5,25V.

Measure the voltage between TP8 and TP12 (Flow Error).

- Range : 0...3V

Troubleshooting:

TEST 37.0

Function:

O₂ Sensor test and pressure sensor adjust for flow measurement

Description:

The zero and full scale settings of the pressure sensor for flow measurement can be adjusted or checked during this test. Also the linearity of the O₂ measurement can be checked.

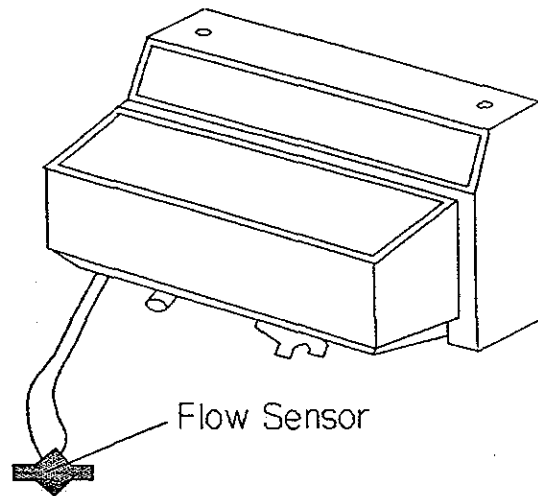
Instrument:

fig. 137_1

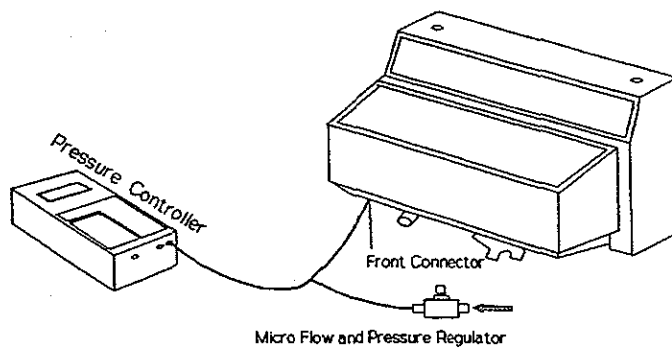


fig. 137_2

Method and Requirements:

Go to Test 37.0 and select position 3 with the monitor selector.

Connect a flow sensor as shown in Figure t37_1.

Adjust the display to "0" \pm 5 mV with the potentiometer R34 on the Mixer/O₂ and Flow Board. (Corresponding with TP4 on mixer board).

Disconnect the Flow Sensor and connect the tubings as shown in Figure t37_2.

Generate a pressure of 2.5 mbar with the micro flow regulator.

This can be measured with the pressure controller. (Make sure that the controller is set at zero on the 0-200 mbar range!)

- The tubing connected to the front most connector shows "-5.08" \pm 200mV on the display.
The rear connector shows "5.08" \pm 200mV.

Disconnect the tubings.

Install the oxygen cell simulator and set the potentiometer on the simulator to 10.0 (= 100 %).

Select position 5 with the monitor selector.

- The O₂ signal display value must read between 3.5V and 6.0V (= Ref. Value).

Set the potentiometer to the settings shown in the following table and check the corresponding display values.

Potentiometer setting	Display value
75%	75 \pm 4% of ref.Value
50%	50 \pm 4% of ref.Value
25%	25 \pm 4% of ref.Value

Note: Don not remove the simulator!

TEST 38.0Function:

Calibration test

Description:

This test runs through a normal calibration (O₂, Flow, Tightness)

Method and Requirements:

Turn the O₂ knob to 21%.

Set the V_T to 20 ml and the rate to 10 bpm.

Switch the instrument off and on again (general reset)

Go to test 38.0

Turn the potentiometer from the O₂ simulator to 10.0 (= 100%)

Switch on the simulator

Turn the monitor selector to position 3.

Press the "O₂ Cal" button for 2 sec.

- The display blinks on and off, showing "CAL".
- After a correct calibration, all calibration LED's blink.

Turn the monitor selector to position 4.

- The display must show 102 ±2.

When the potentiometer from the simulator is turned to:

7.5 (75%), the display shows 75 ±2,

5.0 (50%), the display shows 50 ±2,

2.5 (25%), the display shows 25 ±2.

Switch off and disconnect the simulator.

Connect the O₂ cell holder.

Turn the monitor selector to position 3.

Connect a patient tubing system (without test lung).

Press tightness test and obstruct the tubing system.

- The bargraph shows 60 ± 20 mbar. Within five seconds the unit allows a pressure drop of 10 mbar.

If this test is successful proceed with the flow calibration.

If the display flashes "turn" then turn the Flow Sensor.

- After this test, all calibration LEDs will blink in case no error was being detected.

Troubleshooting:

TEST 38.0**Function:**

Calibration test

Description:

This test runs through a normal calibration (O₂, Flow, Tightness)

Method and Requirements:

Turn the Oxygen knob (Control Board) to 21% .

Switch the instrument off and on again (General reset)

Select test 38.0

Turn the potentiometer from the O₂ simulator to 10.0
(= 100 %)

The control settings of the V_T is 20 ml and the rate is 10 bpm.

Switch on the simulator

Turn the monitor selector to position 3.

Press the O₂ Cal button for 2 sec.

- The display is blinking and shows "Cal".
- After a correct calibration, all calibration LED's blink.

Turn the monitor selector to position 4.

- The display must show "102" ± 2.

When you turn the potentiometer to 7.5 (75 %), the display shows 75 ± 2, 5.0 (50 %) = 50 ± 2 and 2.5 (25 %) = 25 ± 2.

Switch off and disconnect the simulator.

Connect the O₂ cell holder.

Turn the monitor selector to position 3.

Connect a patient tubing system (without test lung).

Press tightness test and obstruct the tubing system.

- The bargraph shows 60 ± 20 mbar. Now the pressure must not decrease faster than 30 mbar in 15 sec, otherwise an error is produced. (To restart a test, the blinking button must be pushed).

If this test was okay, turn the Flow Sensor and press the flow cal button.

- After this test all calibration LEDs will blink in case no error was being detected.

Turn the Flow Sensor again

Troubleshooting:

TEST 39-47

Function:

Flow measurement test

Description:

Different flow will be measured and generated to check the flow measurement.

Method and Requirements:

Disconnect the test lung from the patient circuit.

Turn the PEEP button to 50 mbar

Select Tests 39 to 47 and check each value in each monitor position

Test	Flow (ml/s)	Monitor Selector			Tol. (ml/s)
		2	3	4	
		P _{Pat}	$\frac{U\sqrt{V}}{2}$ [V mV]	Flow	
39	0	0 - 5	-400 - -550	0	±20
40	20	0 - 5	325 - 440	20	0 - 50
41	50	0 - 5	565 - 695	50	20 - 100
42	100	0 - 5	820 - 1005	100	± 20
43	200	0 - 5	1.13 - 1.39	200	± 40
44	500	0 - 5	1.93 - 2.15	500	± 100
45	1000	0 - 5	2.74 - 3.04	1000	± 200
46	2000	0 - 5	3.87 - 4.29	--	--
47	3000	0 - 5	4.75 - 5.25	--	--

Troubleshooting:

TEST 48**Function:**

Tank overpressure valve test

Description:

The magnetic valves are opened and the tank pressure increases until the overpressure valve opens.

Method and Requirements:

Select test 48 and turn the selector to position 2.

- The display shows a value which is less than 503 mbar.

Turn to position 3

- This display is also less than 503 mbar (Ppeak)

Turn the ventilator off and switch off the test software (S5).

Troubleshooting:

30	31	32	33	
----	----	----	----	--

Functional tests

Make a functional test as described in the Operator's Manual.

Adjustment Servo Valve 500 ml/sa) The ventilator works on an altitude below 660 m

To the nominal pressure, written on the orifice, add the correction of the value and adjust the 500 ml/s flow to the new pressure value.

Altitude (meter)	Correction value (mbar)
0	4.3
50	4.0
100	3.6
150	3.3
200	3.0
250	2.7
300	2.3
350	2.0
400	1.7
450	1.4
500	1
550	0.7
600	0.4
650	0.1
660	0.0

Example:	Pressure written on the orifice:	52,0 mbar
	Altitude: 150m; correction:	+ 3,3 mbar
	Adjust the 500 ml/s flow to	<u>55,3 mbar</u>

b) The ventilator works on an altitude above 660 m

Subtract the correction on the value from the nominal pressure written on the orifice and adjust the 500 ml/s flow to the new value.

Altitude (meter)	Correction value (mbar)
660	0
700	0.2
800	0.9
900	1.5
1000	2.1
1100	2.7
1200	3.2
1300	3.8
1400	4.4
1500	5.0
1600	5.5
1700	6.1
1800	6.7
1900	7.2
2000	7.8
2100	8.4

Example:	Pressure written on the orifice:	52,0 mbar
	Altitude: 1600m; correction:	- 5,5 mbar
	Adjust the 500 ml/s flow to	<u>46,5 mbar</u>

Important

This correction is only valid for the "ORIFICE 500 ml/s". The "Capillary Tube 20 ml/s" is not affected by the altitude. However, if you adjust the 500 ml/s flow you also must readjust the 20 ml/s flow.

SECTION 12 OPTIONS

Used with marked Software Version

30	31	32	33	
----	----	----	----	--

12	OPTIONS	12-2
12.1	ANALOG AND DIGITAL INTERFACE	12-2
12.1.1	Interface Installation	12-3
12.1.2	Analog Output Operating Instructions	12-5
12.1.3	Digital Output Operating Instructions	12-6
	SCHEMATIC OF THE INTERFACE	12-11
614016	Block Schematic Diagram	12-11
604561/1	Schematic Diagram	12-12
604561/2	Schematic Diagram	12-13
150510	Board Drawing	12-14
12.2	OPTIONAL PRESSURE SENSOR	12-15
610 376	Tubings AMA P-Sensor	12-16
12.3	PNEUMATIC NEBULIZER	12-17
12.3.1	Activation of the Nebulizer	12-18
	Installation Nebulizer Drawing	12-19

12 OPTIONS

12.1 ANALOG AND DIGITAL INTERFACE

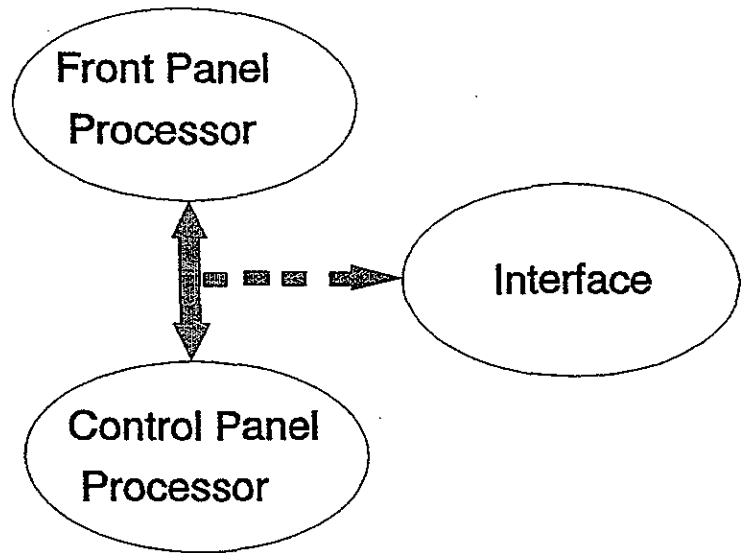


fig.12_1

Analog and digital outputs are available for interfacing the **AMADEUS Ventilator** with recording devices, monitors, printers and computers. The optional interface card is placed within one of the spare circuit card slots inside the ventilator. The analog output uses a standard DB-9 female connector. Available from this connector are analog signals of pressure, optional pressure, flow and volume as well as an inspiratory/expiratory time signal and an alarm relay (for remote alarms). The digital output is RS 232C. This output is formatted for direct printer connection and control by the ventilator operator. Any printer may be used, but it must use a serial, not parallel, input. A special program is available for direct connection to Hewlett-Packard digital monitoring systems. The protocol of the serial output also allows for direct outside computer interfacing.

CAUTION While the **AMADEUS Ventilator** has excellent resistance against electrical interference, the following principles must be followed prior to connecting any device to the Interface:

1. Do not connect several different instruments and/or computers with different noise suppression philosophies via a common ground.
2. Connect only properly functioning, intrinsically safe devices which are galvanically isolated from the main power supply.

SECTION 12 OPTIONS

Used with marked Software Version

30	31	32	33	
----	----	----	----	--

12.1.1 Interface Installation

The printer (or external digital device) and the interface card must be set to receive at the same baud rate and protocol (see your external device manual for information on setting its baud rate and protocol). The output signals are available on a RS 232C plug connector (DB 25 male). The transmission format is asynchronous, serial with 1 start bit, 7 data bits, 1 even parity bit and 2 stop bits. The available transmission baud rates are 1200, 2400, 4800, or 9600. Two different handshake protocols are available:

1. Flag control: Printer READY = high voltage level on control line.
2. XON/XOFF: The printer transmits XON (ASCII DC1 = Hex 11) on its transmission line if it is in a READY state and XOFF (ASCII DC3 = Hex 13) if it is in a BUSY state.

Prior to installing the interface circuit card into the ventilator, six dip switches must be set. These switches (see Figure below) determine the RS 232C output format. The Interface is factory preset for a XON/XOFF protocol and a baud rate of 9600. The switches are as follows :

1. Not used
2. ON (or up) XON/XOFF Protocol (factory setting)
OFF (or down) Flag control Protocol

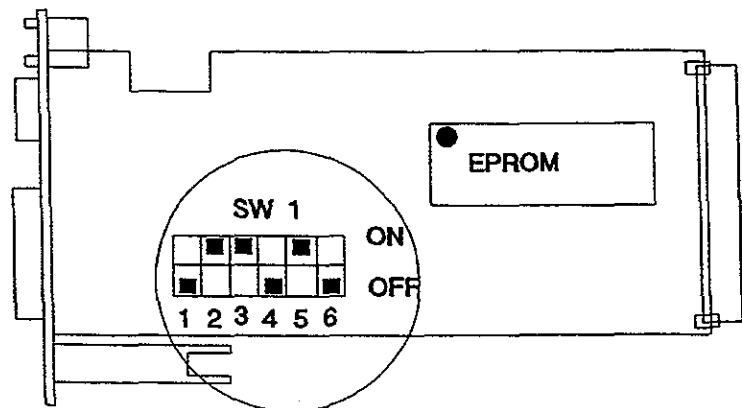


fig.12_2

(For further information see SECTION 13)

SECTION 12 OPTIONS

Used with marked Software Version

30	31	32	33
----	----	----	----

To install the interface card in the ventilator:

1. If connected to a patient, provide alternate ventilatory support and then turn off the **AMADEUS**.
2. Disconnect the power supply cord and remove the top enclosure and rear panel.
3. Remove the metal grid that is attached to the inside of the rear panel which covers the interface opening.
4. Set the baud rate and handshake mode using the DIP switches on the interface board (as described above). The factory setting is 9600 baud rate XON/XOFF mode.
5. Slide the interface card into the rack at the interface position. To insure proper contact with the Mother Board, slide the interface card in and out of its connection several times.
6. Attach the ground (yellow and green) wire to a threaded hole on the top of the rack using the bolt provided.

Note: For SW-Versions earlier than 33, install the "Print" inserts into the control panel. Switch on the DIP-Switch S24 on the Supervisor Board.

7. Re-install the rearpanel and the top enclosure on the ventilator.
8. Attach the instruction sticker to the rear of the ventilator.

The date, time and ventilator number may be put into the memory of the interface card.

To do this:

1. If attached to a patient, provide alternate ventilatory support. Turn the ventilator off.
2. Place option switch number 4 (see section 13) in the on (ON) position.
3. Turn on the ventilator.
4. Follow the directions in the Alarm display panel. You will first be asked to enter the ventilator identification number (don't use number 99, it is reserved for special purposes), then the date and time. The time is set using a 24 hour format. Use the up arrow button to increase the value and the down arrow button to decrease the value. Use the "Yes" button to go to the next value. Use the "No" button to increment the value one number at a time.

SECTION 12 OPTIONS

Used with marked Software Version

30	31	32	33	
----	----	----	----	--

5. When the values are acceptable and you have returned to the ventilator number input, turn the ventilator off.
6. Turn option switch 4 to the off (down) position. The interface card now has the proper information stored in memory.
7. The AMADEUS is now ready for normal operation.

12.1.2 Analog Output Operating Instructions

The analog output is designed for recording devices, monitors, external timing devices and remote alarms. Strip chart as well as X-Y recorders can be driven by this output. The actual analog voltage outputs from the Interface can be matched to the requirements of the external device. Standard Intensive Care Unit ECG monitors with analog pressure inputs display the Interface-outputs as pressure, flow and/or volume wave forms on the monitor screen. External devices which operate in synchronization with a ventilator, such as pneumatic valves, may be directly controlled from the Inspiratory/ Expiratory signal. Remote alarms may be generated with the alarm relay. Consult the device's operators manual for proper use of external analog signals with the device.

The analog output pin assignment is shown in Figure 12_3.

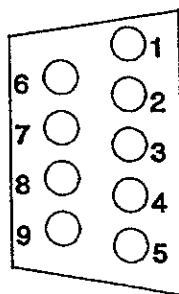


fig.12_3

Pin number Function

- | | | |
|-----|---|---|
| 1 | Alarm relay contact (open when alarm is active) Switching load = 24 volt, 100 mA DC max | |
| 2 | Inspiratory/Expiratory signal
+5 volts during inspiration and pause, 0 volts during expiration | |
| 3 | Pressure, circuit
20 cm H ₂ O = 1 volt | * |
| 4 | Flow, airway
0.5 l/sec = 1 volt | * |
| 5 | Volume, airway
0.5 liter = 1 volt | * |
| 7,8 | Ground | |
| 9 | Pressure, optional airway
20 cm H ₂ O = 1 volt
(* factory setting) | * |

The voltage outputs for the pressure, volume and flow signals can be changed to match the input requirements of the external device. The available ranges are:

SECTION 12 OPTIONS

Used with marked Software Version

30	31	32	33	
----	----	----	----	--

Pressure: 10 to 990 cm H₂O per volt
Volume: 0.1 to 9.9 liters per volt
Flow: 0.1 to 9.9 liters/sec per volt

The procedure to change these signals can be found in the Operator's Manual Section 11.

CAUTION The output signal grounds (positions 7 and 8 above) are directly connected to the **AMADEUS's** internal ground system. To prevent electrical interference signals via this ground connection, observe the following requirements:

1. Use an external device with a floating input ground (differential input).
2. Do not connect the ground signals (positions 7 or 8 above) to the main power ground.
3. Avoid long cables for connection to external devices.
4. To reduce noise on the analog signal, do not use the RS 232C output at the same time as the analog output.
5. Use devices with a high input impedance as the output impedance of the analog signals are 2000 Ohms.

12.1.3 Digital Output Operating Instructions

The digital output is designed for direct connection of the **AMADEUS** to a printer, digital monitor or computer. Most of the data available in the ventilator, including monitored information, control settings, alarm conditions and trend analysis can be acquired through this output. Since the Interface has a battery, data such as date, time, ventilator identification number and trended information are retained in memory, even in the event of power failure.

In order to use a printer with the RS 232C output a properly wired connecting cable is necessary. This cable should be wired to the null modem format (see Figure 12_4) with DB 25 male and female connectors.

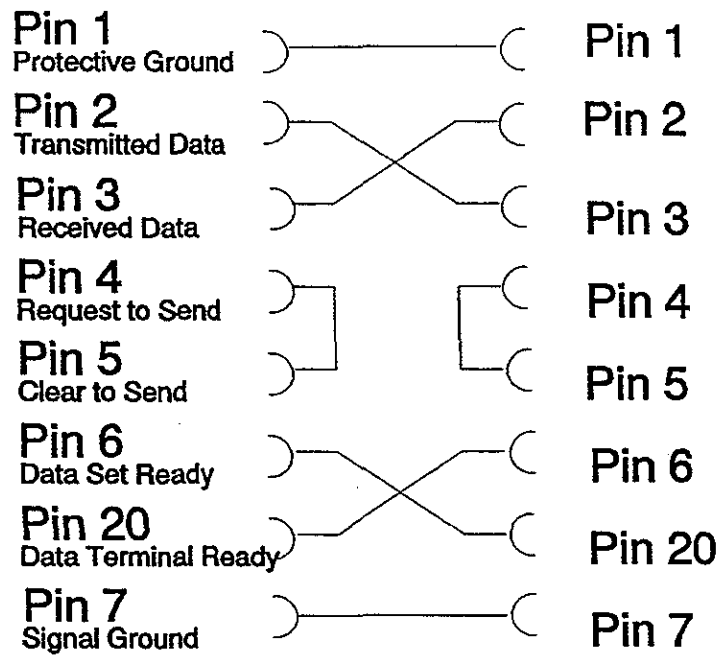


fig.12_4

As stated in the above Sections, any printer with a serial input may be used with this interface. The appropriate control switches must be set to correspond to the settings on the interface card. In addition, the following choices must be set on the printer:

1. RS 232C Protocol switches on the Printer:

- Baud rate: same as Interface
- Parity and data bits: Even and 7 bits
- Handshake mode: same as Interface

2. Mode switches on the Printer:

- Proper language character set
- Proper continuous feed paper size
- Perforation skip mode: OFF
- No auto line feed on a carriage return

The use of a Hewlett Packard Think Jet Printer (model 2225D) is recommended. This printer offers good performance with silent operation. Quiet operation is particularly important in the Intensive Care Unit. For proper communication between the HP Think Jet printer and the HAMILTON MEDICAL AG AMADEUS Interface (with the factory preset switch positions), set the switches on the rear of the printer as follows:

1. RS 232C Protocol switches: 1 = off; 2 = on; 3 = off; 4 = off; 5 = off
2. Mode switches refer to printer manuals. In the USA: all off

CAUTION Hewlett Packard Think Jet printers may have electrical leakage in excess of the legal limits established by some countries for use in Intensive Care Units. Always measure the electrical leakage of any device prior to installation in the Intensive Care Unit. If you have any questions, consult your dealer.

To operate the interface when using a printer:

1. The ventilator should be on and attached to a patient.
2. Attach a properly configured printer (see above instructions) to the interface card with a properly configured cable.
3. Set the program selector switch on the interface card to 0.
4. Place paper in the printer and turn it on.
5. Paper should be in the printer at the proper top of form location with the printer reset to recognize this position. Once properly set, the ventilator will take over the responsibility of maintaining proper top of form for each page that is printed. Do not use the printer's line feed or form feed controls as this will cause an error in paper control. If an error is made, begin again at step number 3 above.
6. Select the desired program format, as listed below, by turning the selector switch on the interface card. Wait at least 3 seconds.
7. Push the two bottom keys see figure 12_5. This will begin the program. "Print History" not available with SW-Version 33. In earlier SW-Versions than 33, press the "Print" button.

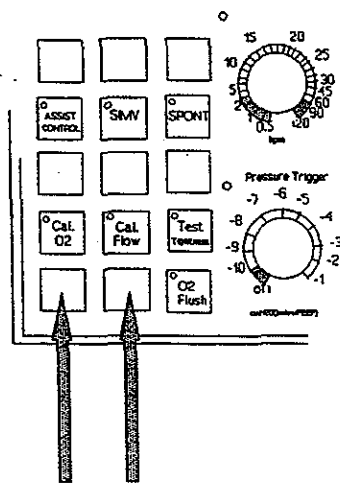


fig.12_5

8. If a different program format is desired, simply select the new format and press the print button. The interface will automatically go to the top of the next page and begin that format. The program selector switch on the interface card allows the operator to select the type and timing of the information output. Programs 1 through 5 will print out medical record quality documentation of patient therapy. Space is available for patient information and operator verification of ventilator performance.

The following printouts can be performed by setting the program selector to position 1 to 6.

The printout of control settings allows for documentation of ventilator control settings and comparison with monitored information. Any changes in controls since the previous output of controls will be highlighted. To print out this press the mode button for the mode you are in (hold down at least 1 second), then the Print button (within 5 seconds).

Printout the 2 hour graphic output of the trended information by pressing the 2 hour trend button and then the Print button (within 5 seconds).

The currently defined programs are:

- Position 0: Interface reset. If left in this position for 3 seconds the interface is reset. This position is also used to reset the printer to a top of form.
- Position 1: Automatic output of monitored information every 15 minutes.
- Position 2: Same as position 1, except the automatic output is every 30 minutes.
- Position 3: Same as position 1, except the automatic output is every hour.
- Position 4: Same as position 1, except the automatic output is every 2 hours.
- Position 5: Manual output of monitored information. Pressing the print button will cause in immediate output of the monitored information.
- Position 6: Manual output, in graphic format, of the last 12 hours of trended information. Pressing the print button will cause a 12 hour graphic printout.
- Position 7: Not used at this time.

SECTION 12 OPTIONS

Used with marked Software Version

30	31	32	33
----	----	----	----

Position 8: For direct connection to Hewlett Packard digital monitoring systems. The program is specifically designed to drive the HP Video Converter model 78355A and an HP Video screen. All **AMADEUS** waveforms and digital information is then available for presentation on the HP system. If this program is used the **AMADEUS** Interface must be set for 1200 baud and the flag control protocol. A special interface cable with DB-25 connectors must be configured as Figure 11_5 describes: For more information on operation of this program, see the appropriate HP supplemental manual.

Position 9: Direct computer communication position. This position allows for direct computer to Interface and Interface to computer communication using the BASIC programming language.

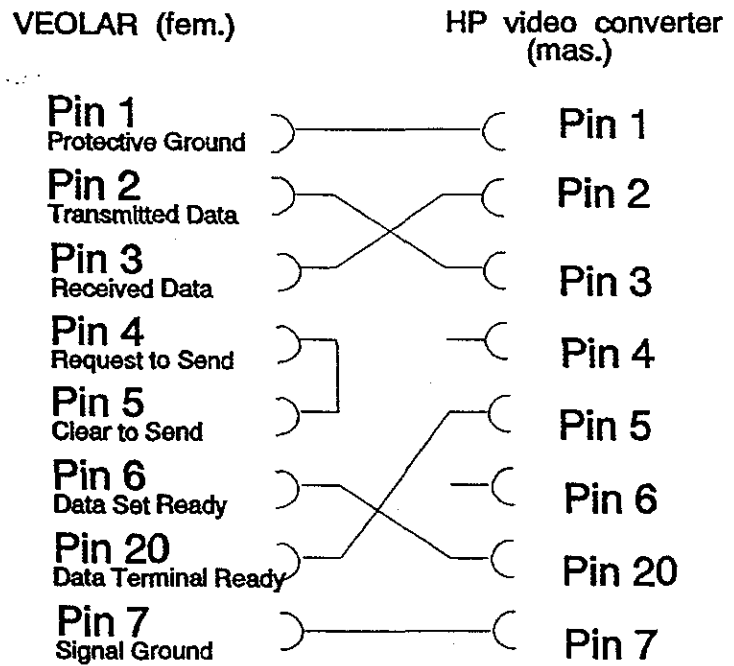
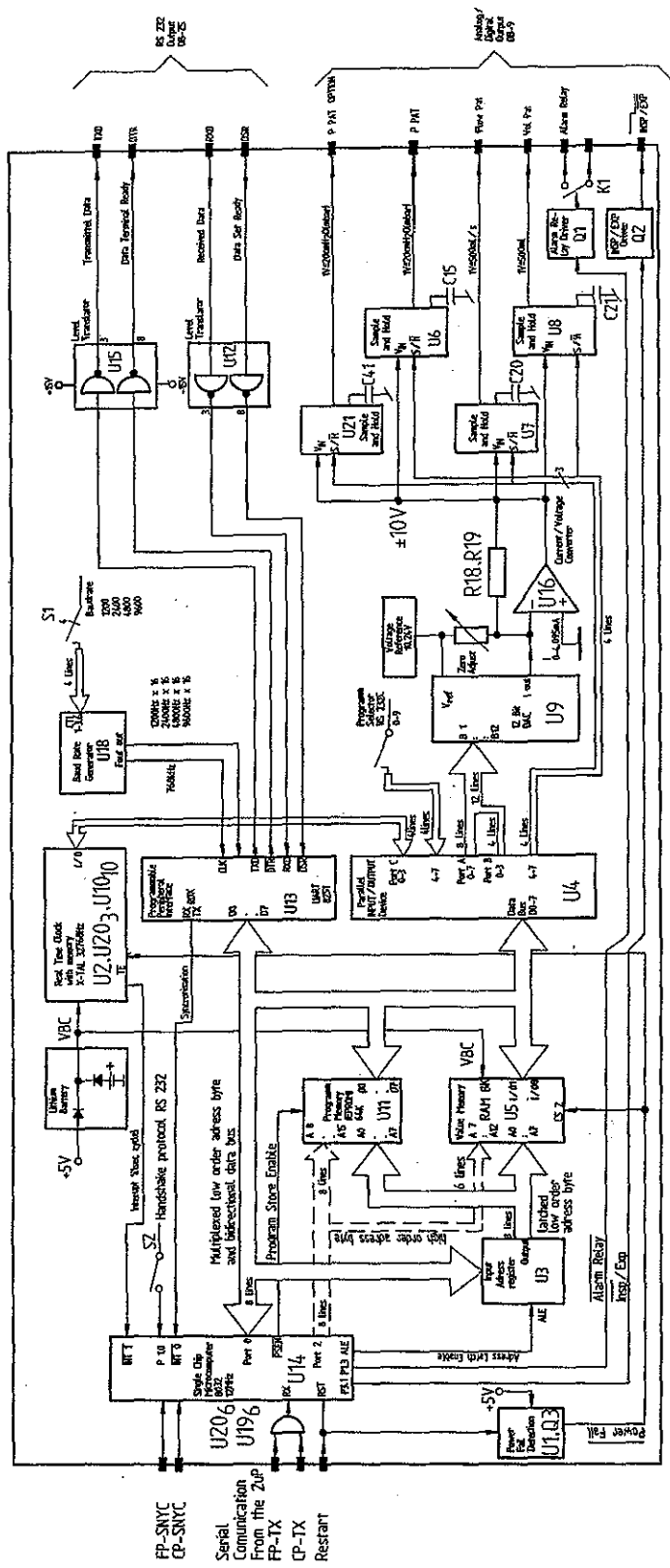


fig.12_6

SECTION 12 OPTIONS

Used with marker 1 Version



Material	Überfläche	Unrolierte Masse	1991-07-01 P.CAL
		Massstab	1994-02-21 A.m.
		Gepl.	1994-02-16 FAJ0Z
			614016

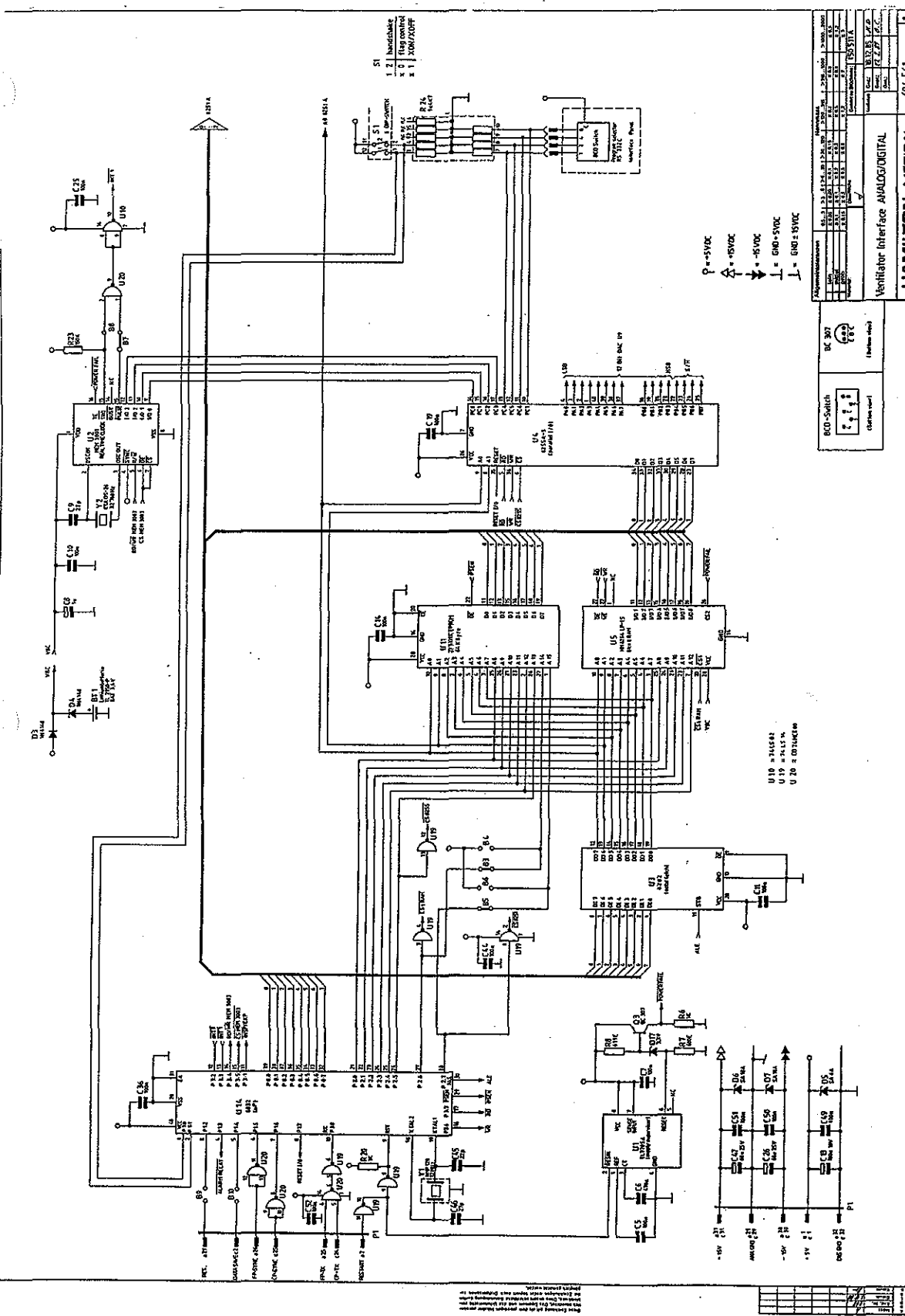
Ventilator Interface Analog / Digital Block schematic
HAMILTON MEDICAL

20.2.1994 03.07cm
HAMILTON MEDICAL AG
Service Manual AMADEUS
Order-No. 610 221 12-11

Diese Zeichnung gilt als dem jeweiligen Inhaber persönlich anvertraut. Das Eigentum und das Urheberrecht verbleibt uns. Ohne unsere schriftliche Genehmigung dürfen die Zeichnungen weder kopiert noch Dritten zugänglich gemacht werden.

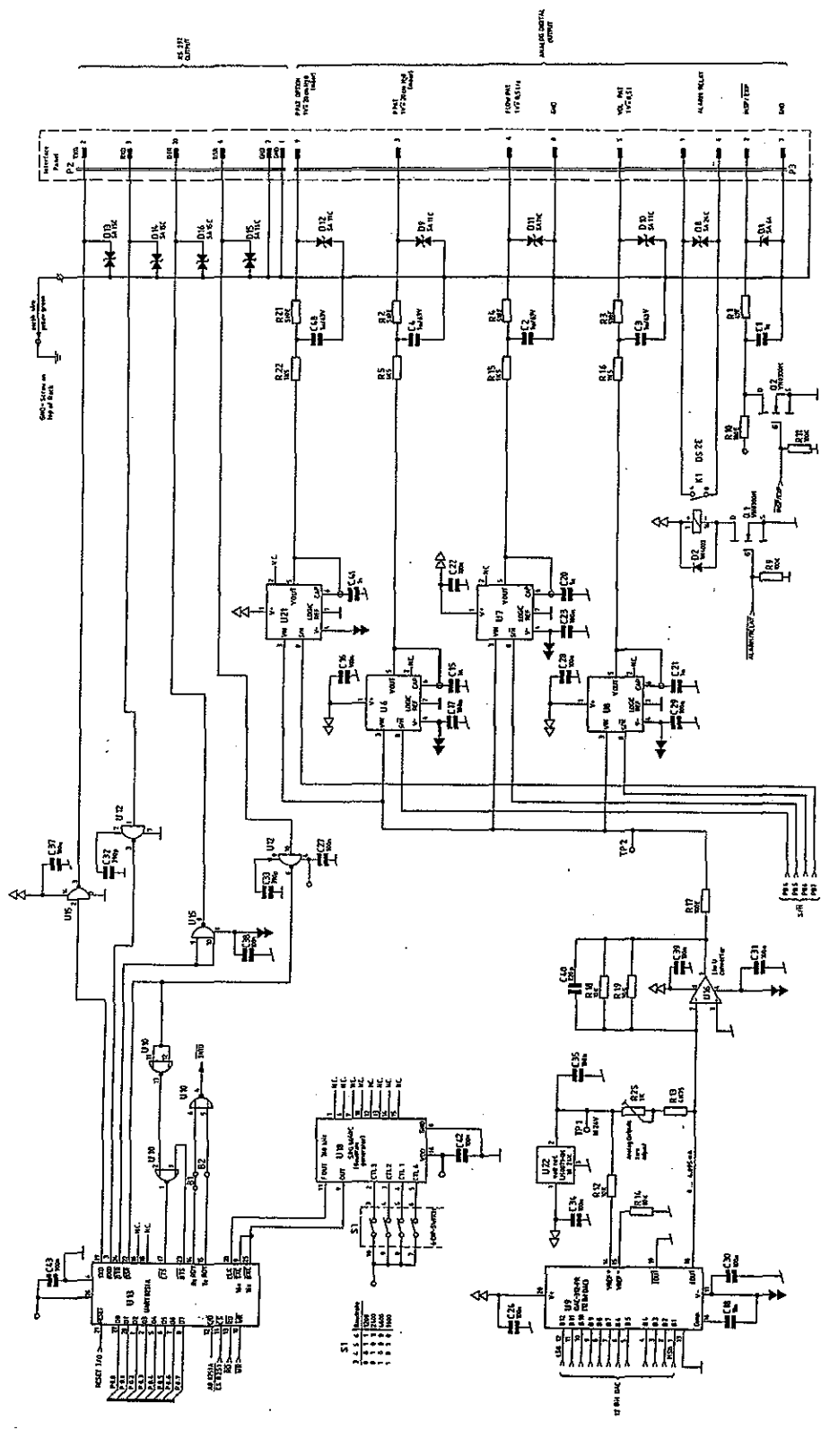
Rev.	01	5589
Änd-Nr.		
D.Nr.		

SECTION 12 OPTIONS



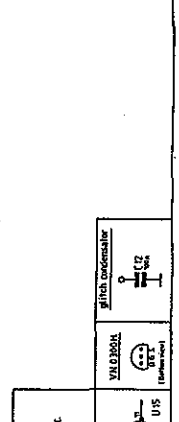
SECTION 12 OPTIONS

Used with marked S... version



Part Number		Quantity	Notes
U1	74LS00	1	
U2	74LS00	1	
U3	74LS00	1	
U4	74LS00	1	
U5	74LS00	1	
U6	LM324	1	
U7	LM324	1	
U8	LM324	1	
U9	LM324	1	
U10	LM324	1	
U11	LM324	1	
U12	74LS00	1	
U13	74LS00	1	
U14	74LS00	1	
U15	74LS00	1	
U16	74LS00	1	
U17	74LS00	1	
U18	74LS00	1	
U19	74LS00	1	
U20	74LS00	1	
U21	74LS00	1	
U22	74LS00	1	
U23	74LS00	1	
U24	74LS00	1	
U25	74LS00	1	
U26	74LS00	1	
U27	74LS00	1	
U28	74LS00	1	
U29	74LS00	1	
U30	74LS00	1	
U31	74LS00	1	
U32	74LS00	1	
U33	74LS00	1	
U34	74LS00	1	
U35	74LS00	1	
U36	74LS00	1	
U37	74LS00	1	
U38	74LS00	1	
U39	74LS00	1	
U40	74LS00	1	
U41	74LS00	1	
U42	74LS00	1	
U43	74LS00	1	
U44	74LS00	1	
U45	74LS00	1	
U46	74LS00	1	
U47	74LS00	1	
U48	74LS00	1	
U49	74LS00	1	
U50	74LS00	1	
U51	74LS00	1	
U52	74LS00	1	
U53	74LS00	1	
U54	74LS00	1	
U55	74LS00	1	
U56	74LS00	1	
U57	74LS00	1	
U58	74LS00	1	
U59	74LS00	1	
U60	74LS00	1	
U61	74LS00	1	
U62	74LS00	1	
U63	74LS00	1	
U64	74LS00	1	
U65	74LS00	1	
U66	74LS00	1	
U67	74LS00	1	
U68	74LS00	1	
U69	74LS00	1	
U70	74LS00	1	
U71	74LS00	1	
U72	74LS00	1	
U73	74LS00	1	
U74	74LS00	1	
U75	74LS00	1	
U76	74LS00	1	
U77	74LS00	1	
U78	74LS00	1	
U79	74LS00	1	
U80	74LS00	1	
U81	74LS00	1	
U82	74LS00	1	
U83	74LS00	1	
U84	74LS00	1	
U85	74LS00	1	
U86	74LS00	1	
U87	74LS00	1	
U88	74LS00	1	
U89	74LS00	1	
U90	74LS00	1	
U91	74LS00	1	
U92	74LS00	1	
U93	74LS00	1	
U94	74LS00	1	
U95	74LS00	1	
U96	74LS00	1	
U97	74LS00	1	
U98	74LS00	1	
U99	74LS00	1	
U100	74LS00	1	

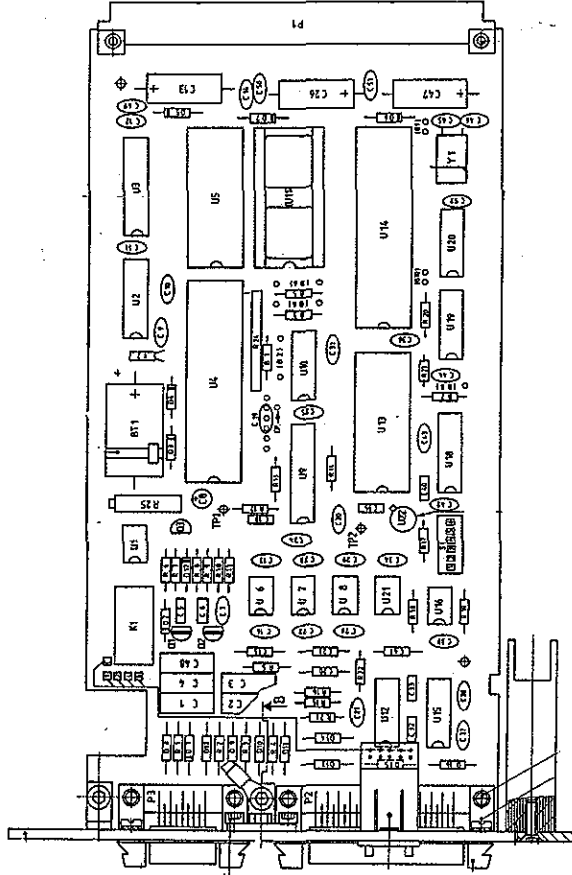
U6 = LM324
 U7 = LM324
 U8 = LM324
 U9 = LM324
 U10 = LM324
 U11 = LM324
 U12 = 74LS00
 U13 = 74LS00
 U14 = 74LS00
 U15 = 74LS00
 U16 = 74LS00
 U17 = 74LS00
 U18 = 74LS00
 U19 = 74LS00
 U20 = 74LS00
 U21 = 74LS00
 U22 = 74LS00
 U23 = 74LS00
 U24 = 74LS00
 U25 = 74LS00
 U26 = 74LS00
 U27 = 74LS00
 U28 = 74LS00
 U29 = 74LS00
 U30 = 74LS00
 U31 = 74LS00
 U32 = 74LS00
 U33 = 74LS00
 U34 = 74LS00
 U35 = 74LS00
 U36 = 74LS00
 U37 = 74LS00
 U38 = 74LS00
 U39 = 74LS00
 U40 = 74LS00
 U41 = 74LS00
 U42 = 74LS00
 U43 = 74LS00
 U44 = 74LS00
 U45 = 74LS00
 U46 = 74LS00
 U47 = 74LS00
 U48 = 74LS00
 U49 = 74LS00
 U50 = 74LS00
 U51 = 74LS00
 U52 = 74LS00
 U53 = 74LS00
 U54 = 74LS00
 U55 = 74LS00
 U56 = 74LS00
 U57 = 74LS00
 U58 = 74LS00
 U59 = 74LS00
 U60 = 74LS00
 U61 = 74LS00
 U62 = 74LS00
 U63 = 74LS00
 U64 = 74LS00
 U65 = 74LS00
 U66 = 74LS00
 U67 = 74LS00
 U68 = 74LS00
 U69 = 74LS00
 U70 = 74LS00
 U71 = 74LS00
 U72 = 74LS00
 U73 = 74LS00
 U74 = 74LS00
 U75 = 74LS00
 U76 = 74LS00
 U77 = 74LS00
 U78 = 74LS00
 U79 = 74LS00
 U80 = 74LS00
 U81 = 74LS00
 U82 = 74LS00
 U83 = 74LS00
 U84 = 74LS00
 U85 = 74LS00
 U86 = 74LS00
 U87 = 74LS00
 U88 = 74LS00
 U89 = 74LS00
 U90 = 74LS00
 U91 = 74LS00
 U92 = 74LS00
 U93 = 74LS00
 U94 = 74LS00
 U95 = 74LS00
 U96 = 74LS00
 U97 = 74LS00
 U98 = 74LS00
 U99 = 74LS00
 U100 = 74LS00



Part Number	Quantity	Notes
U101	1	
U102	1	
U103	1	
U104	1	
U105	1	
U106	1	
U107	1	
U108	1	
U109	1	
U110	1	
U111	1	
U112	1	
U113	1	
U114	1	
U115	1	
U116	1	
U117	1	
U118	1	
U119	1	
U120	1	
U121	1	
U122	1	
U123	1	
U124	1	
U125	1	
U126	1	
U127	1	
U128	1	
U129	1	
U130	1	

SECTION 12. OPTIONS

Used with model 5000 Series Version



Component	Part Number
U1	1
U2	2
U3	3
U4	4
U5	5
U6	6
U7	7
U8	8
U9	9
U10	10
U11	11
U12	12
U13	13
U14	14
U15	15
U16	16

Part Number	Description	Quantity	Unit Price	Total Price
5000	Interface Print Analog/Digital	2:1		
HAMILTON MEDICAL				
50 50				

22-2, 1984, 9:27 AM
 HAMILTON MEDICAL AG
 Service Manual AMADEUS
 Order-No. 610 231 12-14

Bitte beachten Sie die folgenden Hinweise:
 Die Abbildungen sind nur zur Orientierung zu
 den Bauteilen und sind nicht verbindlich.
 Die Bauteile sind nur als Ersatzteile zu
 verwenden.

Part Number	Description	Quantity	Unit Price	Total Price
5000	Interface Print Analog/Digital	2:1		
HAMILTON MEDICAL				
50 50				

12.2 OPTIONAL PRESSURE SENSOR

The Optional Pressure Sensor allows the operator to measure pressures at the patient airway. The pressures are only used for monitoring. The ventilator sensitivity and safety systems will only operate from internally measured pressures.

Installation of this accessory may only be performed by Service Engineers authorized by HAMILTON MEDICAL AG.

Once the Optional Pressure Sensors installed, the operator may select which pressure sensor will, be used for monitoring (i.e.: the internal or the optional).

For Software Version 32 and previous versions:

- Switch the DIP switch S2 at the Supervisor Board to "ON".

In the down (or "Off") position, the ventilator uses the internal pressure sensor for all functions. If the switch is in the up (or "ON") position the ventilator uses the Internal Pressure Sensor for control

purposes and the Optional Sensor for information presented in the Patient Monitor. The microprocessor will only take notice of the position of the switch when the ventilator is initially turned on. Ensure that the switch is in the desired position before turning the ventilator on.

For Software Version 33:

- Switch the DIP switch S22 at the Supervisor Board to 'ON'.

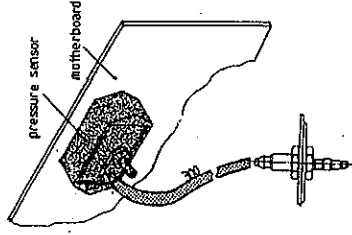
- a key on the Control Panel will allow you to switch from Internal Pressure to Optional Pressure (Esophagal Pressure or Proximal Pressure).

There are three different installation methods for the three different measurements: Optional Pressure, Esophagal Pressure and Proximal Pressure (see drawing 610 376).

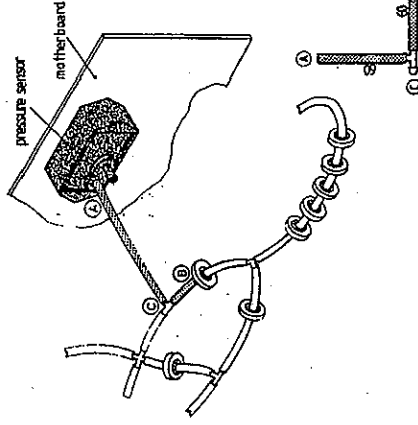
SECTION 12 OPTIONS

Use only with Pressure Monitor

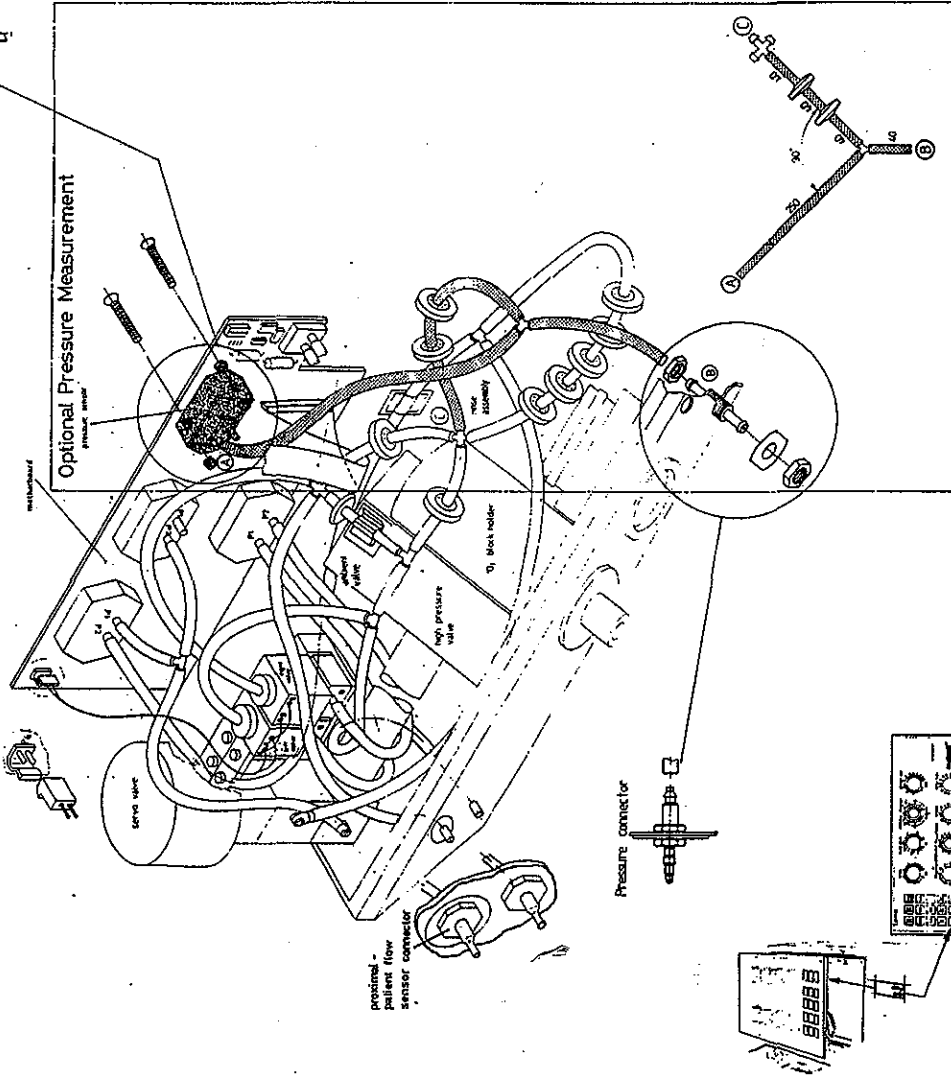
Esophageal Pressure Measurement



Proximal Pressure Measurement



Optional Pressure Measurement



Das Diagramm gibt als Orientierungshilfe die Anordnung der Sensoren an. Die Beschriftungen sind in der Abbildung nicht dargestellt, sondern sind in der Bedienungsanleitung zu finden. Die Beschriftungen sind in der Abbildung nicht dargestellt, sondern sind in der Bedienungsanleitung zu finden.

Umfeld	
Hersteller	AMA
Modell	AMA P-Sensor Kit
Bestell-Nr.	610 376

Tubings AMA P-Sensor Kit

HAMILTON MEDICAL

610 376

22.2.1974 227/81

HAMILTON MEDICAL AG

Service Manual AMADEUS

Order-No. 610 221 12-16

Art-Nr.	5599
Ref.	00

12.3 PNEUMATIC NEBULIZER

A medication micronebulizer can be used with the AMADEUS ventilator. When placed in the ventilator breathing circuit between the inspiratory hose and the "Y-Piece", the micronebulizer is used to provide medication directly into the patient's lungs.

It is important that the proper nebulizer and filter be used. An inline micronebulizer, such as the BIRD micronebulizer, must be used for effective nebulization. The use of a side stream disposable micronebulizer will decrease the volume of nebulized medication during a treatment. A low flow resistance bacteria filter must be used in the gas line between the ventilator and the micronebulizer. This gas line is connected to the nebulizer output connector.

To turn the nebulizer gas flow on, press the "Neb" touch key. The LED in the "Neb" touch key will illuminate to indicate that it is turned on. Gas flow will be delivered during inspiration (in all modes) at the same oxygen concentration as the control setting. This gas flow will operate for 15 minutes and then automatically turn off (in Software Version 33 the 15 minute timer can be switched off). If the operator wishes to turn the gas flow off manually, press the "Neb" touch key again (LED will turn off). The use of a micronebulizer will increase the delivered tidal volume. The ventilator does not compensate for this increased volume. The typical increase in volume is 50 ml during CMV ventilation with a one second inspiratory time. The actual increase in volume is measured and displayed in the Patient Monitor (V_{Temp}).

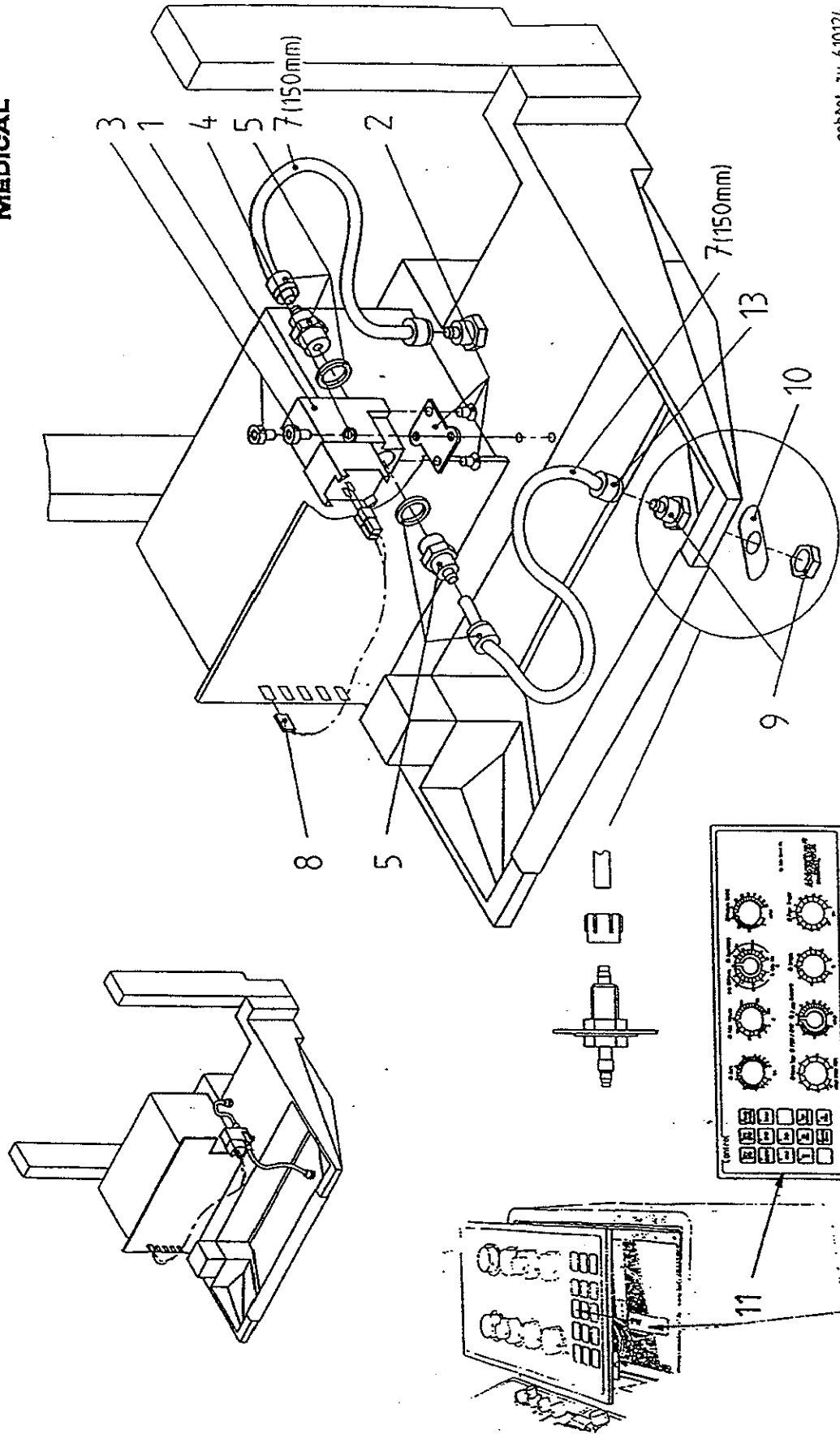
SECTION 12 OPTIONS

Used with marked Software Version

30	31	32	33
----	----	----	----

AMADEUS FT
HAMILTON
MEDICAL

gehört zu 610124



Montagezeichnung Nebulizer / 16 993 IVer / NS01501

13.1	SWITCHES VERSION 33	13-2
13.2	SWITCHES VERSION 32	13-8
13.3	SWITCHES VERSION 31	13-11
13.4	SWITCHES VERSION 30	13-14

SECTION 13 SWITCH SETTINGS	Used with marked Software Version			
	30	31	32	33

13.1 SWITCHES VERSION 33

Control Processor Board :		SW1		
Description	Selection		Factory settings	
		ON	OFF	
S1				S1 <input type="checkbox"/>
S2	*ETS Selection			S2 <input type="checkbox"/>
S3				S3 <input type="checkbox"/>
S4				S4 <input type="checkbox"/>
S5				S5 <input type="checkbox"/>
S6				S6 <input type="checkbox"/>
S7				S7 <input type="checkbox"/>
S8	Nebulizer Timer (15 min)	inactive	active	S8 <input type="checkbox"/>

***ETS Selection**

ETS [%]	12.5		18.75		31.25		37.5	
	ON	OFF	ON	OFF	ON	OFF	ON	OFF
S3	<input type="checkbox"/>	<input checked="" type="checkbox"/>	<input checked="" type="checkbox"/>	<input type="checkbox"/>	<input checked="" type="checkbox"/>	<input type="checkbox"/>	<input checked="" type="checkbox"/>	<input type="checkbox"/>
S4	<input checked="" type="checkbox"/>	<input type="checkbox"/>	<input checked="" type="checkbox"/>	<input type="checkbox"/>	<input checked="" type="checkbox"/>	<input type="checkbox"/>	<input checked="" type="checkbox"/>	<input type="checkbox"/>

Control Processor Board		SW2		
EPROM selection with switch		Selection		Factory settings
Description		ON	OFF	
S1	Eprom selection 512 KBit			S1 <input checked="" type="checkbox"/>
S2				S2 <input checked="" type="checkbox"/>

Frontpanel Processor Board :		SW1		
Description	Selection		Factory settings	
		ON	OFF	
S1				S1 <input type="checkbox"/>
S2				S2 <input type="checkbox"/>
S3				S3 <input type="checkbox"/>
S4				S4 <input type="checkbox"/>
S5				S5 <input type="checkbox"/>
S6				S6 <input type="checkbox"/>
S7				S7 <input type="checkbox"/>
S8				S8 <input type="checkbox"/>

Frontpanel Processor Board		SW2		
EPROM selection with switch		Selection		Factory settings
Description		ON	OFF	
S1	Eprom selection 512 kBit			S1 <input checked="" type="checkbox"/>
S2				S2 <input checked="" type="checkbox"/>

SECTION 13 SWITCH SETTINGS

Used with marked Software Version

30 31 32 33

Supervisorboard, user accessible:		SW1				
Description		Selection			Factory settings	
		ON	OFF		ON	OFF
S1	Backup	active	inactive	S1	<input type="checkbox"/>	<input checked="" type="checkbox"/>
S2	Pediatric	active	inactive	S2	<input type="checkbox"/>	<input checked="" type="checkbox"/>
S3	Sigh	active	inactive	S3	<input type="checkbox"/>	<input checked="" type="checkbox"/>
S4	Data entry Interface	active	inactive	S4	<input type="checkbox"/>	<input checked="" type="checkbox"/>
S5	Testsoftware	active	inactive	S5	<input type="checkbox"/>	<input checked="" type="checkbox"/>
S6	ETS	special (see CP board)	25%	S6	<input type="checkbox"/>	<input checked="" type="checkbox"/>
S7	Apnea	40 sec	20 sec	S7	<input type="checkbox"/>	<input checked="" type="checkbox"/>
S8	switch 'ON' and 'OFF' to disable the fan alarm			S8	<input type="checkbox"/>	<input checked="" type="checkbox"/>

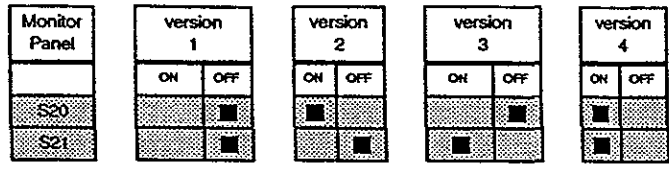
Supervisorboard, user accessible:		SW2				
Description		Selection			Factory settings	
		ON	OFF		ON	OFF
S9	Flow pattern	special(see S17, S18 and S19)	square	S1	<input type="checkbox"/>	<input checked="" type="checkbox"/>
S10				S2	<input type="checkbox"/>	<input checked="" type="checkbox"/>
S11				S3	<input type="checkbox"/>	<input checked="" type="checkbox"/>
S12				S4	<input type="checkbox"/>	<input checked="" type="checkbox"/>
S13				S5	<input type="checkbox"/>	<input checked="" type="checkbox"/>
S14				S6	<input type="checkbox"/>	<input checked="" type="checkbox"/>
S15				S7	<input type="checkbox"/>	<input checked="" type="checkbox"/>
S16				S8	<input type="checkbox"/>	<input checked="" type="checkbox"/>

Supervisorboard, internal:		SW3				
Description		Selection			Factory settings	
		ON	OFF		ON	OFF
S17	**Flow Pattern Selection			S1	<input type="checkbox"/>	<input checked="" type="checkbox"/>
S18				S2	<input type="checkbox"/>	<input checked="" type="checkbox"/>
S19				S3	<input type="checkbox"/>	<input checked="" type="checkbox"/>
S20	***Monitor Version Selection			S4	<input type="checkbox"/>	<input checked="" type="checkbox"/>
S21				S5	<input type="checkbox"/>	<input checked="" type="checkbox"/>
S22	Optional Pressure Sensor	active	inactive	S6	<input type="checkbox"/>	<input checked="" type="checkbox"/>
S23	Nebulizer Function	active	inactive	S7	<input type="checkbox"/>	<input checked="" type="checkbox"/>
S24				S8	<input type="checkbox"/>	<input checked="" type="checkbox"/>

**Flow Pattern Selection

Flow Pattern	triangle accelerating	square	triangle decelerating	sine	triangle dec.(133% to 66%)	triangle acc. (33 to 133%)	sine with high peak
	ON OFF	ON OFF	ON OFF	ON OFF	ON OFF	ON OFF	ON OFF
S17	<input type="checkbox"/> <input checked="" type="checkbox"/>	<input type="checkbox"/> <input checked="" type="checkbox"/>	<input type="checkbox"/> <input checked="" type="checkbox"/>	<input type="checkbox"/> <input checked="" type="checkbox"/>	<input type="checkbox"/> <input checked="" type="checkbox"/>	<input type="checkbox"/> <input checked="" type="checkbox"/>	<input type="checkbox"/> <input checked="" type="checkbox"/>
S18	<input type="checkbox"/> <input checked="" type="checkbox"/>	<input type="checkbox"/> <input checked="" type="checkbox"/>	<input checked="" type="checkbox"/> <input type="checkbox"/>	<input checked="" type="checkbox"/> <input type="checkbox"/>	<input type="checkbox"/> <input checked="" type="checkbox"/>	<input type="checkbox"/> <input checked="" type="checkbox"/>	<input type="checkbox"/> <input checked="" type="checkbox"/>
S19	<input type="checkbox"/> <input checked="" type="checkbox"/>	<input checked="" type="checkbox"/> <input type="checkbox"/>	<input type="checkbox"/> <input checked="" type="checkbox"/>	<input type="checkbox"/> <input checked="" type="checkbox"/>	<input checked="" type="checkbox"/> <input type="checkbox"/>	<input checked="" type="checkbox"/> <input type="checkbox"/>	<input type="checkbox"/> <input checked="" type="checkbox"/>

*****Monitor Version Selection**



Monitor Panel USA/GB

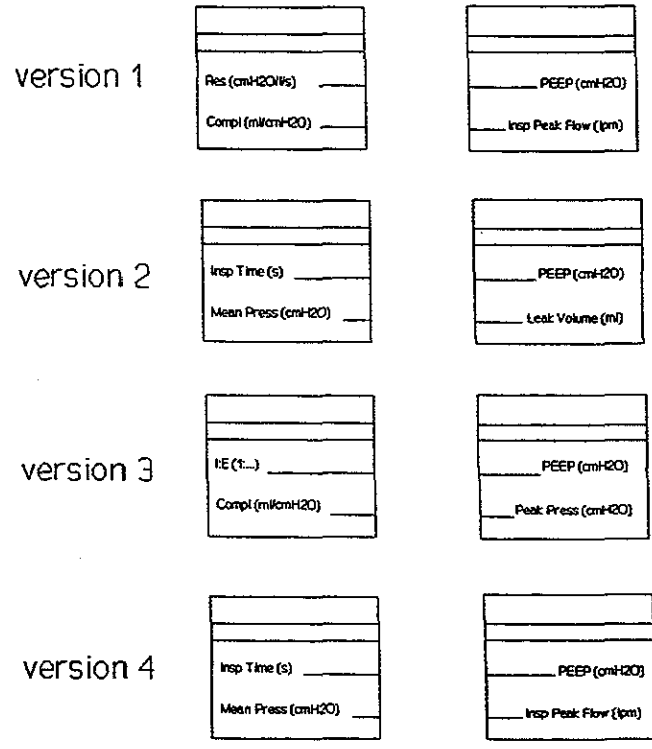


fig. 13_1

SECTION 13 SWITCH SETTINGS

Used with marked Software Version

30	31	32	33
----	----	----	----

Monitor Panel German

version 1

R (mbar/l/s) _____
C (ml/mbar) _____

PEEP (mbar) _____
Insp max Flow (l/min) _____

version 2

t Insp (s) _____
p mittel (mbar) _____

PEEP (mbar) _____
Volumenverlust (ml) _____

version 3

IE (1:...) _____
C (ml/mbar) _____

PEEP (mbar) _____
pmax (mbar) _____

version 4

t Insp (s) _____
p mittel (mbar) _____

PEEP (mbar) _____
Insp max Flow (l/min) _____

Monitor Panel French

version 1

Résist (cmH ₂ O/l/s) _____
Compl (ml/cmH ₂ O) _____

PEEP (cmH ₂ O) _____
Débit crête In (l/min) _____

version 2

Temps Insp (s) _____
Press moy (cmH ₂ O) _____

PEP (cmH ₂ O) _____
Fuite (ml) _____

version 3

IE (1:...) _____
Compl (ml/cmH ₂ O) _____

PEEP (cmH ₂ O) _____
Press de pointe (cmH ₂ O) _____

version 4

Temps Insp (s) _____
Press moyenne (cmH ₂ O) _____

PEEP (cmH ₂ O) _____
Débit crête In (l/min) _____

fig. 13_2

SECTION 13 SWITCH SETTINGS

Used with marked Software Version

30 31 32 33

Mixer, O2 & Flow Board:		SW1			
Description		Selection		Factory settings	
		ON	OFF	ON	OFF
S1	****Elevation Selection			S1	<input checked="" type="checkbox"/>
S2				S2	<input checked="" type="checkbox"/>
S3				S3	<input checked="" type="checkbox"/>
S4				S4	<input checked="" type="checkbox"/>
S5				S5	<input checked="" type="checkbox"/>
S6				S6	<input checked="" type="checkbox"/>
S7				S7	<input checked="" type="checkbox"/>
S8				S8	<input checked="" type="checkbox"/>

****Elevation Selection

Elevation (meter above see Level)	0...400		400...900		900...1500		1500...	
	ON	OFF	ON	OFF	ON	OFF	ON	OFF
S1	<input type="checkbox"/>	<input checked="" type="checkbox"/>	<input type="checkbox"/>	<input checked="" type="checkbox"/>	<input checked="" type="checkbox"/>	<input type="checkbox"/>	<input checked="" type="checkbox"/>	<input type="checkbox"/>
S2	<input type="checkbox"/>	<input checked="" type="checkbox"/>	<input checked="" type="checkbox"/>	<input type="checkbox"/>	<input type="checkbox"/>	<input checked="" type="checkbox"/>	<input checked="" type="checkbox"/>	<input type="checkbox"/>

Pressure Control Board:		SW1			
Description		Selection		Factory settings	
		ON	OFF	ON	OFF
S1		active	inactive	S1	<input checked="" type="checkbox"/>
S2		active	inactive	S2	<input checked="" type="checkbox"/>

SECTION 13 SWITCH SETTINGS	Used with marked Software Version			
	30	31	32	33

Interface Board :		SW1			
Description		Selection		Factory settings	
		ON	OFF		
S1				S1	■
S2	Protocol	XON/XOFF	Flag control	S2	■
S3	*****Baud rate selection			S3	■
S4				S4	■
S5				S5	■
S6				S6	■

*****Baud rate selection

S3	OFF	OFF	ON	ON
S4	OFF	ON	OFF	OFF
S5	ON	OFF	OFF	ON
S6	ON	ON	OFF	OFF
	1200	2400	4800	9600

SECTION 13 SWITCH SETTINGS	Used with marked Software Version				
	30	31	32	33	

13.2 SWITCHES VERSION 32

Control Processor Board : SW1					
Description	Selection		Factory settings		
	ON	OFF		ON	OFF
S1			S1	<input type="checkbox"/>	<input checked="" type="checkbox"/>
S2			S2	<input type="checkbox"/>	<input checked="" type="checkbox"/>
S3			S3	<input type="checkbox"/>	<input checked="" type="checkbox"/>
S4			S4	<input type="checkbox"/>	<input checked="" type="checkbox"/>
S5			S5	<input type="checkbox"/>	<input checked="" type="checkbox"/>
S6			S6	<input type="checkbox"/>	<input checked="" type="checkbox"/>
S7			S7	<input type="checkbox"/>	<input checked="" type="checkbox"/>
S8			S8	<input type="checkbox"/>	<input checked="" type="checkbox"/>

Control Processor Board EPROM selection with switch SW2					
Description	Selection		Factory settings		
	ON	OFF		ON	OFF
S1	Eprom selection 256 KBit		S1	<input checked="" type="checkbox"/>	<input type="checkbox"/>
S2			S2	<input type="checkbox"/>	<input checked="" type="checkbox"/>

Frontpanel Processor Board : SW1					
Description	Selection		Factory settings		
	ON	OFF		ON	OFF
S1			S1	<input type="checkbox"/>	<input checked="" type="checkbox"/>
S2			S2	<input type="checkbox"/>	<input checked="" type="checkbox"/>
S3			S3	<input type="checkbox"/>	<input checked="" type="checkbox"/>
S4			S4	<input type="checkbox"/>	<input checked="" type="checkbox"/>
S5			S5	<input type="checkbox"/>	<input checked="" type="checkbox"/>
S6			S6	<input type="checkbox"/>	<input checked="" type="checkbox"/>
S7			S7	<input type="checkbox"/>	<input checked="" type="checkbox"/>
S8			S8	<input type="checkbox"/>	<input checked="" type="checkbox"/>

Frontpanel Processor Board EPROM selection with switch SW2					
Description	Selection		Factory settings		
	ON	OFF		ON	OFF
S1	Eprom selection 512 kBit		S1	<input checked="" type="checkbox"/>	<input type="checkbox"/>
S2			S2	<input checked="" type="checkbox"/>	<input type="checkbox"/>

SECTION 13 SWITCH SETTINGS

Used with marked Software Version

30 31 32 33

Supervisorboard, user accessible:		SW1				
Description		Selection		Factory settings		
		ON	OFF		ON	OFF
S1	Backup	active	inactive	S1		<input checked="" type="checkbox"/>
S2	P _{ORTOK}	active	inactive	S2		<input checked="" type="checkbox"/>
S3				S3		<input checked="" type="checkbox"/>
S4	Data entry Interface	active	inactive	S4		<input checked="" type="checkbox"/>
S5	Testsoftware	active	inactive	S5		<input checked="" type="checkbox"/>
S6				S6		<input checked="" type="checkbox"/>
S7				S7		<input checked="" type="checkbox"/>
S8	switch 'ON' and 'OFF' to disable the fan alarm			S8		<input checked="" type="checkbox"/>

Supervisorboard, user accessible:		SW2				
Description		Selection		Factory settings		
		ON	OFF		ON	OFF
S9	Flow pattern (see S17, S18 and S19)	active	inactive	S1		<input checked="" type="checkbox"/>
S10				S2		<input checked="" type="checkbox"/>
S11				S3		<input checked="" type="checkbox"/>
S12				S4		<input checked="" type="checkbox"/>
S13				S5		<input checked="" type="checkbox"/>
S14				S6		<input checked="" type="checkbox"/>
S15				S7		<input checked="" type="checkbox"/>
S16				S8		<input checked="" type="checkbox"/>

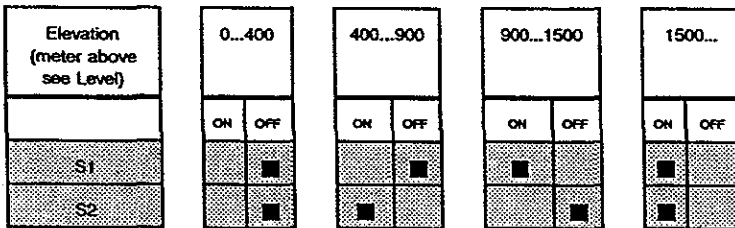
Supervisorboard, internal:		SW3				
Description		Selection		Factory settings		
		ON	OFF		ON	OFF
S17	*Flow Pattern Selection			S1		<input checked="" type="checkbox"/>
S18				S2		<input checked="" type="checkbox"/>
S19				S3		<input checked="" type="checkbox"/>
S20				S4		<input checked="" type="checkbox"/>
S21				S5		<input checked="" type="checkbox"/>
S22				S6		<input checked="" type="checkbox"/>
S23	Nebulizer Function	active	inactive	S7		<input checked="" type="checkbox"/>
S24	Printer Function	active	inactive	S8		<input checked="" type="checkbox"/>

*Flow Pattern Selection

Flow Pattern	triangle accelerating	square	triangle decelerating	sine	triangle dec.(133% to 66%)	triangle acc. (33 to 133%)	sine with high peak	
	ON	OFF	ON	OFF	ON	OFF	ON	OFF
S17	<input checked="" type="checkbox"/>	<input type="checkbox"/>	<input checked="" type="checkbox"/>	<input type="checkbox"/>	<input checked="" type="checkbox"/>	<input type="checkbox"/>	<input checked="" type="checkbox"/>	<input type="checkbox"/>
S18	<input type="checkbox"/>	<input checked="" type="checkbox"/>	<input type="checkbox"/>	<input checked="" type="checkbox"/>	<input type="checkbox"/>	<input checked="" type="checkbox"/>	<input type="checkbox"/>	<input checked="" type="checkbox"/>
S19	<input type="checkbox"/>	<input type="checkbox"/>	<input type="checkbox"/>	<input checked="" type="checkbox"/>	<input type="checkbox"/>	<input checked="" type="checkbox"/>	<input type="checkbox"/>	<input checked="" type="checkbox"/>

Mixer, O2 & Flow Board:		SW1			
Description		Selection		Factory settings	
		ON	OFF		
S1	**Elevation Selection			S1	<input checked="" type="checkbox"/>
S2		S2	<input type="checkbox"/>	<input checked="" type="checkbox"/>	
S3				S3	<input checked="" type="checkbox"/>
S4				S4	<input type="checkbox"/>
S5				S5	<input checked="" type="checkbox"/>
S6				S6	<input checked="" type="checkbox"/>
S7				S7	<input checked="" type="checkbox"/>
S8				S8	<input checked="" type="checkbox"/>

****Elevation Selection**



Interface Board :		SW1			
Description		Selection		Factory settings	
		ON	OFF		
S1				S1	<input checked="" type="checkbox"/>
S2	Protocol	XON/XOFF	Flag control	S2	<input checked="" type="checkbox"/>
S3	***Baud rate selection			S3	<input checked="" type="checkbox"/>
S4		S4	<input type="checkbox"/>	<input checked="" type="checkbox"/>	
S5		S5	<input checked="" type="checkbox"/>	<input type="checkbox"/>	
S6		S6	<input type="checkbox"/>	<input checked="" type="checkbox"/>	

*****Baud rate selection**

S3	OFF	OFF	ON	ON
S4	OFF	ON	OFF	OFF
S5	ON	OFF	OFF	ON
S6	ON	ON	OFF	OFF
	1200	2400	4800	9600

SECTION 13 SWITCH SETTINGS	Used with marked Software Version			
	30	31	32	33

13.3 SWITCHES VERSION 31

Control Processor Board :		SW1				
Description	Selection		Factory settings			
	ON	OFF		ON	OFF	
S1			S1	<input type="checkbox"/>	<input checked="" type="checkbox"/>	
S2			S2	<input type="checkbox"/>	<input checked="" type="checkbox"/>	
S3			S3	<input type="checkbox"/>	<input checked="" type="checkbox"/>	
S4			S4	<input type="checkbox"/>	<input checked="" type="checkbox"/>	
S5			S5	<input type="checkbox"/>	<input checked="" type="checkbox"/>	
S6			S6	<input type="checkbox"/>	<input checked="" type="checkbox"/>	
S7			S7	<input type="checkbox"/>	<input checked="" type="checkbox"/>	
S8			S8	<input type="checkbox"/>	<input checked="" type="checkbox"/>	

Control Processor Board		EPROM selection with switch		SW2		
Description	Selection		Factory settings			
	ON	OFF		ON	OFF	
S1	Eprom selection 256 KBit		S1	<input checked="" type="checkbox"/>	<input type="checkbox"/>	
S2			S2	<input type="checkbox"/>	<input checked="" type="checkbox"/>	

Frontpanel Processor Board :		SW1				
Description	Selection		Factory settings			
	ON	OFF		ON	OFF	
S1			S1	<input type="checkbox"/>	<input checked="" type="checkbox"/>	
S2			S2	<input type="checkbox"/>	<input checked="" type="checkbox"/>	
S3			S3	<input type="checkbox"/>	<input checked="" type="checkbox"/>	
S4			S4	<input type="checkbox"/>	<input checked="" type="checkbox"/>	
S5			S5	<input type="checkbox"/>	<input checked="" type="checkbox"/>	
S6			S6	<input type="checkbox"/>	<input checked="" type="checkbox"/>	
S7			S7	<input type="checkbox"/>	<input checked="" type="checkbox"/>	
S8			S8	<input type="checkbox"/>	<input checked="" type="checkbox"/>	

Frontpanel Processor Board		EPROM selection with switch		SW2		
Description	Selection		Factory settings			
	ON	OFF		ON	OFF	
S1	Eprom selection 256 kBit		S1	<input checked="" type="checkbox"/>	<input type="checkbox"/>	
S2			S2	<input type="checkbox"/>	<input checked="" type="checkbox"/>	

SECTION 13 SWITCH SETTINGS	Used with marked Software Version			
	30	31	32	33

Supervisorboard, user accessible:		SW1			
Description		Selection		Factory settings	
		ON	OFF	ON	OFF
S1	Backup	active	inactive	S1	<input type="checkbox"/>
S2	P _{alarm}	active	inactive	S2	<input type="checkbox"/>
S3				S3	<input type="checkbox"/>
S4	Data entry Interface	active	inactive	S4	<input type="checkbox"/>
S5	Testsoftware	active	inactive	S5	<input type="checkbox"/>
S6				S6	<input type="checkbox"/>
S7				S7	<input type="checkbox"/>
S8	switch 'ON' and 'OFF' to disable the fan alarm			S8	<input type="checkbox"/>

Supervisorboard, user accessible:		SW2			
Description		Selection		Factory settings	
		ON	OFF	ON	OFF
S9	Flow pattern (see S17, S18 and S19)	active	inactive	S1	<input type="checkbox"/>
S10				S2	<input type="checkbox"/>
S11				S3	<input type="checkbox"/>
S12				S4	<input type="checkbox"/>
S13				S5	<input type="checkbox"/>
S14				S6	<input type="checkbox"/>
S15				S7	<input type="checkbox"/>
S16				S8	<input type="checkbox"/>

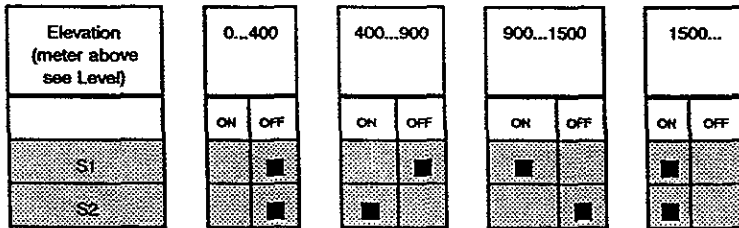
Supervisorboard, internal:		SW3			
Description		Selection		Factory settings	
		ON	OFF	ON	OFF
S17	*Flow Pattern Selection			S1	<input type="checkbox"/>
S18				S2	<input type="checkbox"/>
S19				S3	<input type="checkbox"/>
S20				S4	<input type="checkbox"/>
S21				S5	<input type="checkbox"/>
S22				S6	<input type="checkbox"/>
S23	Nebulizer Function	active	inactive	S7	<input type="checkbox"/>
S24	Printer Function	active	inactive	S8	<input type="checkbox"/>

***Flow Pattern Selection**

Flow Pattern	triangle accelerating		square		triangle decelerating		sine		triangle dec. (133% to 66%)		triangle acc. (33 to 133%)		sine with high peak	
	ON	OFF	ON	OFF	ON	OFF	ON	OFF	ON	OFF	ON	OFF	ON	OFF
S17		<input type="checkbox"/>	<input type="checkbox"/>	<input type="checkbox"/>	<input type="checkbox"/>	<input type="checkbox"/>	<input type="checkbox"/>	<input type="checkbox"/>	<input type="checkbox"/>	<input type="checkbox"/>	<input type="checkbox"/>	<input type="checkbox"/>	<input type="checkbox"/>	<input type="checkbox"/>
S18	<input type="checkbox"/>	<input type="checkbox"/>	<input type="checkbox"/>	<input type="checkbox"/>	<input type="checkbox"/>	<input type="checkbox"/>	<input type="checkbox"/>	<input type="checkbox"/>	<input type="checkbox"/>	<input type="checkbox"/>	<input type="checkbox"/>	<input type="checkbox"/>	<input type="checkbox"/>	<input type="checkbox"/>
S19	<input type="checkbox"/>	<input type="checkbox"/>	<input type="checkbox"/>	<input type="checkbox"/>	<input type="checkbox"/>	<input type="checkbox"/>	<input type="checkbox"/>	<input type="checkbox"/>	<input type="checkbox"/>	<input type="checkbox"/>	<input type="checkbox"/>	<input type="checkbox"/>	<input type="checkbox"/>	<input type="checkbox"/>

Mixer, O2 & Flow Board:		SW1			
Description		Selection		Factory settings	
		ON	OFF		
S1	**Elevation Selection			S1	<input checked="" type="checkbox"/>
S2				S2	<input type="checkbox"/>
S3				S3	<input checked="" type="checkbox"/>
S4				S4	<input type="checkbox"/>
S5				S5	<input type="checkbox"/>
S6				S6	<input type="checkbox"/>
S7				S7	<input type="checkbox"/>
S8				S8	<input type="checkbox"/>

****Elevation Selection**



Interface Board :		SW1			
Description		Selection		Factory settings	
		ON	OFF		
S1				S1	<input type="checkbox"/>
S2	Protocol	XON/XOFF	Flag control	S2	<input checked="" type="checkbox"/>
S3	***Baud rate selection			S3	<input checked="" type="checkbox"/>
S4				S4	<input type="checkbox"/>
S5				S5	<input checked="" type="checkbox"/>
S6				S6	<input type="checkbox"/>

*****Baud rate selection**

	OFF	OFF	ON	ON
S3	OFF	ON	OFF	OFF
S4	ON	OFF	OFF	ON
S5	ON	ON	OFF	OFF
S6	1200	2400	4800	9600

SECTION 13 SWITCH SETTINGS

Used with marked Software Version

30	31	32	33
----	----	----	----

13.4 SWITCHES VERSION 30

Control Processor Board :		SW1		Factory settings		
Description	Selection			ON	OFF	
	ON	OFF		ON	OFF	
S1			S1	<input type="checkbox"/>	<input checked="" type="checkbox"/>	
S2			S2	<input type="checkbox"/>	<input checked="" type="checkbox"/>	
S3			S3	<input type="checkbox"/>	<input checked="" type="checkbox"/>	
S4			S4	<input type="checkbox"/>	<input checked="" type="checkbox"/>	
S5			S5	<input type="checkbox"/>	<input checked="" type="checkbox"/>	
S6			S6	<input type="checkbox"/>	<input checked="" type="checkbox"/>	
S7			S7	<input type="checkbox"/>	<input checked="" type="checkbox"/>	
S8			S8	<input type="checkbox"/>	<input checked="" type="checkbox"/>	

Control Processor Board		EPROM selection with switch		SW2			Factory settings		
Description	Selection			ON	OFF		ON	OFF	
	ON	OFF		ON	OFF		ON	OFF	
S1			S1	<input checked="" type="checkbox"/>	<input type="checkbox"/>	S1	<input checked="" type="checkbox"/>	<input type="checkbox"/>	
S2	Eprom selection 256 KBit		S2	<input type="checkbox"/>	<input checked="" type="checkbox"/>	S2	<input type="checkbox"/>	<input checked="" type="checkbox"/>	

Frontpanel Processor Board :		SW1		Factory settings		
Description	Selection			ON	OFF	
	ON	OFF		ON	OFF	
S1			S1	<input type="checkbox"/>	<input checked="" type="checkbox"/>	
S2			S2	<input type="checkbox"/>	<input checked="" type="checkbox"/>	
S3			S3	<input type="checkbox"/>	<input checked="" type="checkbox"/>	
S4			S4	<input type="checkbox"/>	<input checked="" type="checkbox"/>	
S5			S5	<input type="checkbox"/>	<input checked="" type="checkbox"/>	
S6	*Flow Pattern Selection		S6	<input type="checkbox"/>	<input checked="" type="checkbox"/>	
S7			S7	<input type="checkbox"/>	<input checked="" type="checkbox"/>	
S8			S8	<input type="checkbox"/>	<input checked="" type="checkbox"/>	

*Flow Pattern Selection

Flow Pattern	triangle accelerating	square	triangle decelerating	sine	triangle dec.(133% to 66%)	triangle acc. (33 to 133%)	sine with high peak	
	ON	OFF	ON	OFF	ON	OFF	ON	OFF
S6	<input checked="" type="checkbox"/>	<input type="checkbox"/>	<input checked="" type="checkbox"/>	<input type="checkbox"/>	<input checked="" type="checkbox"/>	<input type="checkbox"/>	<input checked="" type="checkbox"/>	<input type="checkbox"/>
S7	<input type="checkbox"/>	<input checked="" type="checkbox"/>	<input type="checkbox"/>	<input checked="" type="checkbox"/>	<input type="checkbox"/>	<input checked="" type="checkbox"/>	<input type="checkbox"/>	<input checked="" type="checkbox"/>
S8	<input type="checkbox"/>	<input checked="" type="checkbox"/>	<input type="checkbox"/>	<input checked="" type="checkbox"/>	<input type="checkbox"/>	<input checked="" type="checkbox"/>	<input type="checkbox"/>	<input checked="" type="checkbox"/>

SECTION 13 SWITCH SETTINGS	Used with marked Software Version			
	30	31	32	33

Frontpanel Processor Board EPROM selection with switch SW2					
Description		Selection		Factory settings	
		ON	OFF		ON OFF
S1				S1	■
S2	Eprom selection 256 kBit			S2	■

Supervisorboard, user accessible: SW1					
Description		Selection		Factory settings	
		ON	OFF		ON OFF
S1				S1	■
S2	P _{OPTION}	active	inactive	S2	■
S3				S3	■
S4	Data entry Interface	active	inactive	S4	■
S5	Testsoftware	active	inactive	S5	■
S6				S6	■
S7				S7	■
S8	switch 'ON' and 'OFF' to disable the fan alarm			S8	■

Supervisorboard, user accessible: SW2					
Description		Selection		Factory settings	
		ON	OFF		ON OFF
S9	Flow pattern (see S17, S18 and S19)	spezial	square	S1	■
S10				S2	■
S11				S3	■
S12				S4	■
S13				S5	■
S14				S6	■
S15				S7	■
S16				S8	■

Supervisorboard, internal: SW3					
Description		Selection		Factory settings	
		ON	OFF		ON OFF
S17				S1	■
S18				S2	■
S19				S3	■
S20				S4	■
S21				S5	■
S22				S6	■
S23				S7	■
S24	Printer Function	active	inactive	S8	■

SECTION 13 SWITCH SETTINGS	Used with marked Software Version			
	30	31	32	33

Mixer, O2 & Flow Board:		SW1			
Description	Selection		Factory settings		
		ON	OFF		
S1	***Elevation Selection			S1	<input checked="" type="checkbox"/>
S2			S2	<input type="checkbox"/>	
S3			S3	<input checked="" type="checkbox"/>	
S4			S4	<input type="checkbox"/>	
S5			S5	<input type="checkbox"/>	
S6			S6	<input type="checkbox"/>	
S7			S7	<input type="checkbox"/>	
S8			S8	<input type="checkbox"/>	

***Elevation Selection

Elevation (meter above see Level)	0...400		400...900		900...1500		1500...	
	ON	OFF	ON	OFF	ON	OFF	ON	OFF
S1	<input type="checkbox"/>	<input checked="" type="checkbox"/>	<input type="checkbox"/>	<input checked="" type="checkbox"/>	<input checked="" type="checkbox"/>	<input type="checkbox"/>	<input type="checkbox"/>	<input checked="" type="checkbox"/>
S2	<input type="checkbox"/>	<input checked="" type="checkbox"/>	<input checked="" type="checkbox"/>	<input type="checkbox"/>	<input type="checkbox"/>	<input checked="" type="checkbox"/>	<input type="checkbox"/>	<input type="checkbox"/>

Interface Board :		SW1			
Description	Selection		Factory settings		
		ON	OFF		
S1				S1	<input type="checkbox"/>
S2	Protocol	XON/XOFF	Flag control	S2	<input checked="" type="checkbox"/>
S3	****Baud rate selection			S3	<input checked="" type="checkbox"/>
S4			S4	<input type="checkbox"/>	
S5			S5	<input checked="" type="checkbox"/>	
S6			S6	<input type="checkbox"/>	

****Baud rate selection

S3	OFF	OFF	ON	ON
S4	OFF	ON	OFF	OFF
S5	ON	OFF	OFF	ON
S6	ON	ON	OFF	OFF
	1200	2400	4800	9600

14 MODIFICATION

14.1 MODIFICATION OVERVIEW

Since the first AMADEUS was released some modifications have been implemented. The main modifications are listed below.

Serial Number	Date	Modification
1001	October 88	<ul style="list-style-type: none"> First Edition · AFP30S.8 --> 256kBit · NCP30.8L --> 256kBit · RMI0201 --> 256 kBit
1041	June 89	<ul style="list-style-type: none"> · AFP30S.A · NCP30.12C · RMI0300
1364	September 90	<ul style="list-style-type: none"> · O₂ Cell Block 153910 (Connectors from flat to pointed)
1403	November 90	<ul style="list-style-type: none"> · Supervisor Board 153320 Rev.02 (Buzzer removed from the Supervisor Board) · Double Buzzer released and fixed to the rack
1424	December 90	<ul style="list-style-type: none"> · AFP31S.1 · NCP31A.2 · Fan Check System implemented (Fan Alarm Suppression with DIP switch S8 on the Supervisor Board) · Monitor Selector Knob Modification (Consult Test 6.1) · Backup Function (Using the DIP switch S1 on the Supervisor Board) · Pressure Control Board 150420 (Capacitor C16 changes from 22nF to 150NF)
1730	September 92	<ul style="list-style-type: none"> · AFP32S.1 --> 512kBit · NCP32A.1 · Auto Zero Assembly for Flow Measurement · Expiration Valve 151470 Rev.02 (Smooth plunger implemented, although the black ring with holes remained unchanged)
1810	January 92	<ul style="list-style-type: none"> · RMI0301 (Technical Fault 12 during Flow Calibration)
1820	February 93	<ul style="list-style-type: none"> · AFP32S.2 · NCP32A.2 (Auto Zero Assembly handling improved)
1850	April 93	<ul style="list-style-type: none"> · Double Buzzer 153982 Rev.03 (Plug modified)
2011	March 94	<ul style="list-style-type: none"> · NCP33A.6 · AFP33B.0/AFP33F.0/AFP33X.0 RMI33A.0 · Flow Trigger and PCV-knob · P-optional key on the Control Panel · Mixer, O₂ and Flow Board 153380 · Pressure Control Board 150425 · Expiration Valve 151465 · Servo Valve 151871 (packed 151882) · Control and Monitor Panel (light blue) · Rear Panel 153263 (optional switches description printed) · Monitor Parameters Inserts · Rins Assembly 153270

15 AMADEUS SOFTWARE OVERVIEW

Verify the correct EPROMs for a certain software version:

Combination of the AMADEUS-, Interface- and the LEONARDO Software		Instrument EPROMs			
		NCP30.12C AFP30S.1 RMI0300 or RMI0301	NCP31A.2 AFP31S.1 RMI0300 or RMI0301	NCP32A.1 AFP32S.1 or NCP32A.2 AFP32S.2 RMI0300 or RMI0301	NCP33A.6 AFP33B.0 or AFP33F.0 or AFP33X.0 RMI33A.0
Interface EPROMs	NIK 004	Leonardo 1.6 / 1.6A 1.71A	Leonardo 1.6 / 1.6A 1.71A	Leonardo 1.6 / 1.6A 1.71A	Leonardo 1.6 / 1.6A 1.71A
	NIK 01S.1	Leonardo 1.6 / 1.6A 1.71A	Leonardo 1.6 / 1.6A 1.71A	Leonardo 1.6 / 1.6A 1.71A	Leonardo 1.6 / 1.6A 1.71A