

Graseby 3400 Anaesthesia Syringe Pump

TECHNICAL SERVICE MANUAL

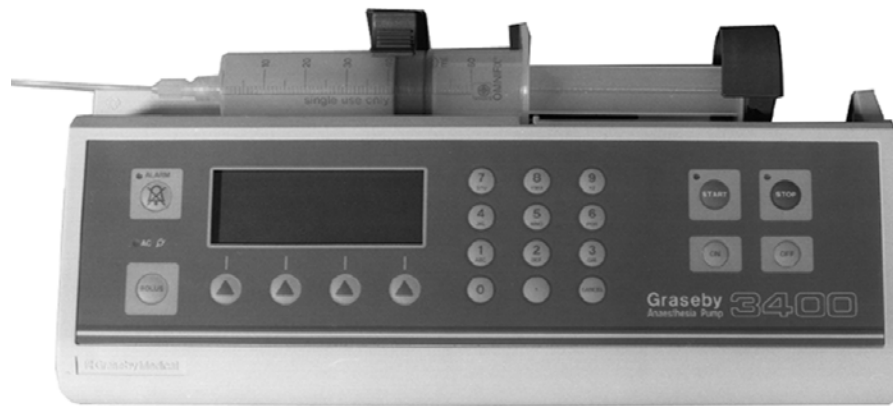

***sims* GRASEBY**

CE
0473

Document Number 00SM-0132 Issue 6.0

Published by SIMS Graseby Limited.

All possible care has been taken in the preparation of this publication, but SIMS Graseby Limited accepts no liability for any inaccuracies that may be found.

SIMS Graseby reserves the right to make changes without notice both to this publication and to the product which it describes.

© **SIMS Graseby Limited 1999**

No part of this publication may be reproduced, transmitted, transcribed, or stored in a retrieval system or translated into any human or computer language in any form by any means without the prior permission of SIMS Graseby Limited.

SIMS GRASEBY LIMITED,
COLONIAL WAY,
WATFORD,
HERTFORDSHIRE,
UNITED KINGDOM,
WD2 4LG

TEL: (+44) (0)1923 246434
FAX: (+44) (0)1923 231595

REGISTERED IN ENGLAND. COMPANY No. 995550

LIST OF CONTENTS

	Page
General	x
Warnings and caution	x
Abbreviations used	xi

CHAPTER 1

INTRODUCTION, FEATURES, CLASSIFICATION AND SPECIFICATION

Introduction	1-1
General information	1-1
Features	1-3
Classification	1-3
Specification	1-4
Brief history of Graseby bedside syringe pumps	1-5

CHAPTER 2

CONFIGURATION & DIAGNOSTIC MODE, AND THRUST ADJUSTMENTS

Configuration mode	2-1
Calling up the configuration mode	2-2
Changing an option	2-2
Moving to the next parameter	2-2
Configuration parameters and settings that are available	
Syringe brands	2-2
Display language	2-3
Bolus beep	2-3
Preset bolus dose	2-3
Mass units	2-3
LCD contrast	2-3
Baud rate	2-3
Max rate	2-3
Diagnostic mode	2-4
Calling up the Diagnostic mode	2-4
Moving to the next parameter	2-4
Diagnostic displays	2-4
Exiting from the Diagnostic mode	2-5

CHAPTER 2 (contd.)

	Page
Disassembly and assembly of casing	2-5
Taking the casing apart	2-5
Assembly	2-5
Occlusion measurements	2-6
Thrust measurements	2-6
Syringe stiction	2-6
Thrust checks	2-7
Thrust adjustments	2-8

CHAPTER 3

FUNCTIONAL DESCRIPTIONS

Introduction	3-1
Drive system	3-1
DC motor and leadscrew	3-1
Processor	3-1
Toggle mechanism	3-1
Plunger clamp	3-1
Occlusion sensing system	3-2
Clutch assembly and opto-sensor	3-2
Occlusion detection	3-2
Electro/mechanical control system	3-2
Motor speed	3-2
Motor rotation	3-2
Mechanical characteristics	3-2
Sensing (alarm) systems	3-3
Introduction	3-3
Syringe nearly empty	3-3
End of infusion/occlusion	3-3
AC power failure	3-3
Battery voltage low	3-3
Self tests/pump malfunction	3-3
Drive disengaged, or syringe not fitted	3-3
Syringe sizing system	3-3
Software	3-4
Design methods	3-4
Self tests	3-4

CHAPTER 4

CIRCUIT DESCRIPTIONS

	Page
Introduction	4-1
Main board circuit	4-2
Sub-circuits	4-2
Processor core circuit	4-2
Description	4-2
Motor interface circuit description	4-3
Introduction	4-3
Motor current control	4-3
Transients; suppression	4-3
Motor speed control	4-3
Power control circuit	4-4
Logic circuit supply; Vcc	4-4
RAM and clock supply	4-4
Sensors interface circuit	4-4
Introduction	4-4
Circuit description	4-4
RS232 Interface circuit	4-5
Circuit description	4-5
Input/output circuit	4-5
Front panel interface	4-5
LED illumination	4-6
Real time clock	4-6
Liquid crystal display	4-6
Sounder	4-6
Regulator board circuit	4-7
Introduction	4-7
Live circuit and T1 primary description	4-7
T1 secondary	4-7
Batteries circuit	4-7
Overvoltage protection	4-8
Plug PL11 outputs	4-8
Setting RV1	4-8
Size sensors and board	4-9
Opto sensors and board	4-9
Umbilical board connections	4-9
Umbilical cable connector	4-9

CHAPTER 5

FAULT CODES, CLEANING AND REPAIRS

	Page
Fault codes	5-1
Cleaning	5-3
Repair procedures	5-3
Introduction	5-3
Renewal of fuses	5-3
Regulator board renewal	5-4
Main board renewal	5-4
Displacement of the Umbilical board tray	5-4
Umbilical board renewal	5-5
Opto sensors board renewal	5-5
Plunger clamp and super nut assembly renewal	5-5
Pole clamp renewal	5-6
Leadscrew assembly renewal	5-6
Removal	5-6
Renewal	5-7
Releasing the spring pressure	5-7
Case assy and checks	5-7
Motor and gearbox assembly renewal	5-7
Occlusion clutch and disc assy renewal	5-7
Membrane switch panel renewal	5-8
Super nut renewal	5-8
Syringe size sensor board renewal	5-9
Plunger clamp repair	5-10
Batteries. Checks and replacement	5-10
Front and/or rear case repair	5-10

CHAPTER 6

FUNCTIONAL TESTS

Introduction	6-1
Plunger clamp alarm checks	6-4
Ramp check procedures	6-4
Linear accuracy	6-5
Test procedures	6-5
Plunger clamp alignment	6-5
Test procedures	6-5

CHAPTER 7	Page
ILLUSTRATED PARTS LISTS	
General assembly	7-1
Plunger clamp and half nut assemblies	7-6
Pole clamp assembly: non-rotating	7-7
Pole clamp assembly: rotating	7-8
Leadscrew assembly	7-9
Opto sensors board assembly	7-10
Size sensors board assembly	7-11
Main board assembly	7-12
Regulator board assembly	7-15
Distribution board assembly	7-17
CHAPTER 8	
BRAUN PERFUSOR CONVERSION	
Syringe conversion procedures	8-1
Introduction	8-1
Nearly empty flag conversion	8-1
Spacer tube fitment	8-1
Plunger clamp plate fitment	8-1
Reassembling case	8-1
Braun Perfusor selection	8-1
'P' label fitment	8-1
Selecting 'various' syringe brands	8-2
Mechanical procedures	8-2
Programming procedures	8-2
APPENDIX	
FITMENT OF NEW MODIFIED SIZE SENSOR FLAG rear of manual	
Introduction	A-1
Warnings	A-2
Caution	A-2
Opening the case	A-2
Removal of old SSF	A-2
Reassembly	A-3
Final testing	A-3
Setting the Size Sensor Flag	A-4

LIST OF FIGURES

Figure	Page
1.1 Front view of the 3400 pump	1-2
2.1 Thrust measuring set up	2-7
4.1 Overall block diagram of the 3400 system	4-10
4.2 Main board block diagram	4-11
4.3 Processor core circuit diagram	4-12
4.4 Motor interface circuit diagram	4-13
4.5 Power control circuit diagram	4-14
4.6 Sensors interface circuit diagram	4-15
4.7 Communications (RS232) circuit diagram	4-16
4.8 Main board input/output interface circuit diagram	4-17
4.9 Umbilical cable connections diagram	4-18
4.10 Umbilical board connections diagram	4-19
4.11 Regulator circuit diagram (overview)	4-21
4.12 Regulator live circuit diagram	4-22
4.13 Regulator isolated circuit diagram	4-23
4.14 Main board: layout of components	4-24
4.15 Regulator board: layout of components	4-25
4.16 Syringe size sensors circuit diagram	4-26
4.17 Syringe size sensors board: layout of components	4-26
4.18 Opto sensors circuit diagram	4-27
4.19 Opto sensors board: layout of components	4-27
4.20 Umbilical board: layout of components	4-28
4.21 Membrane switch panel	4-29
4.22 Internal ribbon cable and 'D' connector connections	4-30
7.1 General assembly	7-3
7.2 Plunger clamp and half nut assembly	7-6
7.3a Pole clamp assembly: non-rotating	7-7
7.3b Pole clamp assembly: rotating	7-8
7.4 Leadscrew assembly	7-9
7.5 Opto sensors board assembly	7-10
7.6 Size sensors board assembly	7-11
7.7 Main board assembly	7-13
7.8 Regulator board assembly	7-16
7.9 Distribution board assembly	7-17
8.1 Braun Perfusor conversion: parts required	8-2
A.1 New modified Size Sensor Flag	A-1
A.2 Order of tightening the case screws	A-3
A.3 Size Sensor Flag: general details	A-4

LIST OF TABLES

Table	Page
2.1 Syringe size and max. auto. continuous infusion rate	2-3
4.1 RS232 'D' connector connections	4-5
4.2 Temperature/voltage range for setting RV1	4-8
5.1 Diagnostic fault codes	5-1
5.2 Front case spares kit.....	5-11
5.2 Size Sensor Flag spares kit	5-11
5.4 Rear case spares kit	5-11
6.1 Functional tests.....	6-1
7.1 General assembly	7-1
7.2 Plunger clamp and half nut assembly	7-6
7.3a Pole clamp assembly: non-rotating	7-7
7.3b Pole clamp assembly: rotating	7-8
7.4 Leadscrew assembly	7-9
7.5 Opto sensors board assembly	7-10
7.6 Size sensors board assembly	7-11
7.7 Main board assembly	7-12
7.8 Regulator board assembly	7-15
7.9 Distribution board assembly	7-17

General

This Technical Service Manual (TSM) together with the Instruction Manual for the 3400, contains the information that is required in order to carry out the following actions to the pump:

- operation,
- maintenance,
- repair.

The TSM is primarily intended to be read and used by suitably qualified personnel.

Warnings and cautions are given throughout this manual and are repeated below.

Warnings

Only qualified personnel should maintain and repair the pump.

The pump's Configuration or Diagnostic mode must only be used by personnel who have been adequately trained in how to use the pump and have been assigned to enter these modes.

The pump must be disconnected from the AC power supply prior to opening the casing.

During the setting of RV1 dangerous AC voltages may be present when the case is open.

Do not immerse the pump in any liquids. Immediately wipe off any liquid accidentally spilt on the pump.

The safety and reliability of the pump may be compromised by the use of parts other than those specified in this Manual.

The pump must be set to display the brand and size of syringe that is going to be used. Using a different brand or size of syringe to the one that is going to be used could lead to the incorrect amount of drug being administered, resulting in injury or death.

When a new Size Sensor Flag has been fitted, then the pump must be tested using the Syringe Size sensor Gauges available from SIMS Graseby (Part No. 0131- 0202). The Appendix, Page 3 gives details of the Final Testing procedures required.

Only items of equipment that conform to EN60950 may be connected to the 9-pin RS232 connector that is situated at the rear of the pump. This conformity will prevent the safety of the patient being compromised.

When using a syringe smaller than 50/60 ml on a pump the occlusion pressure will increase as the diameter of the syringe decreases, i.e. the smaller the syringe the higher the pressure.

The internal pump batteries must be disposed of in accordance with the manufacturers instructions. Lead acid batteries must not be placed in the normal waste stream.

Cautions

As with all computer electronic equipment, high powered electromagnetic radiation, such as from diathermy equipment in close proximity, can affect the operation of the pump, although no hazard will be caused.

The pump is not suitable for use in the presence of flammable anaesthetics mixture with air, with oxygen or nitrous oxide.

The Printed Circuit Boards (PCB) contained in the pump are electrostatically sensitive. Use an earthing strap when handling a PCB to avoid electrostatic damage to the components situated on the PCB. Ensure that replacement PCB are stored in anti-static containers.

Abbreviations used The following list shows the abbreviations that have been used at various places throughout this Manual.

<u>Abbreviation</u>	<u>Full name</u>
A	Ampere
A to D	Analogue to Digital
AC	Alternating Current
C	Capacitor
°C	Degrees Celsius
CPU	Central Processing Unit
cm	Centimetre
csk	Counter-sunk
CRC	Cyclic Redundancy Check
DC	Direct Current
Fig.	Figure
g	Gram
Hg	Mercury
Hz	Hertz
IC	Integrated Circuit
kg	Kilogram
KVO	Keep Vein Open
LED	Light Emitting Diode
MCI	Manually Controlled Infusion
mA	Milliampere
mg	Milligram
ml	Millilitre
mm	Millimetre
PCA	Patient Controlled Analgesia
PCB	Printed Circuit Board
PL	Plug
PWM	Pulse Width Modulation
PFS	Prefilled syringe
R	Resistor
R.F.	Radio Frequency
RAM	Random Access Memory
ROM	Read Only Memory
V	Volts

CHAPTER 1

INTRODUCTION, FEATURES, CLASSIFICATION AND SPECIFICATION

**3400
ANAESTHESIA SYRINGE PUMP**

CHAPTER 1

INTRODUCTION, FEATURES, CLASSIFICATION AND SPECIFICATION

Introduction

The 3400 anaesthesia syringe pump (Fig. 1.1) is based on a micro-controller design and has been purpose developed by Graseby for the administration of anaesthetics, mainly in a hospital operating theatre.

The pump allows a Manually Controlled Infusion, and/or a bolus to be infused using the normal brands of syringe. The infusion entails presetting into the pump both the required infusion rate and the dose of the drug that is going to be used.

The pump can be configured by a suitably qualified person to work with any one of several selected brands of syringe, plus, when converted, the Braun Perfusor syringe. The particular brand of syringe selected will be displayed.

The diameter of the syringe installed is automatically sensed by the pump and from this dimension and knowing the syringe brand the pump is able to calculate and display the following syringe sizes:

5; 10; 20; 30 and 60 millilitres.

The pump is a compact robust unit that is able to function either sitting on a table top or mounted on an IV pole via the pumps pole clamp.

General information

The pump can be configured to:

- deliver a volume or mass unit, manual controlled infusion, or
- a volume or mass unit bolus infusion.

A running total of the volume of liquid that has been infused is stored in the pump's totaliser, and will remain available for display even though the infusion may have been stopped and then restarted. The totaliser can be set to zero when required.

The pump can be operated from AC power or from internal rechargeable batteries. When functioning on fully charged batteries, and under normal conditions, the pump gives more than ten hours of continual use.

The AC power can vary between 100 V and 250 V and 50 to 60 Hz, thus allowing the pump to be used anywhere in the world without adjustment.

A battery charging circuit within the pump keeps the batteries charged. The batteries are fully charged when the AC power has been connected to the pump for 14 hours, even though the pump itself may be switched off.

Numerous safety features have been built into both the software and the hardware, and the user is warned of such incidents as a power failure or an occlusion by both visible and audible alarms. The pump carries out a self-testing routine each time it is switched on.

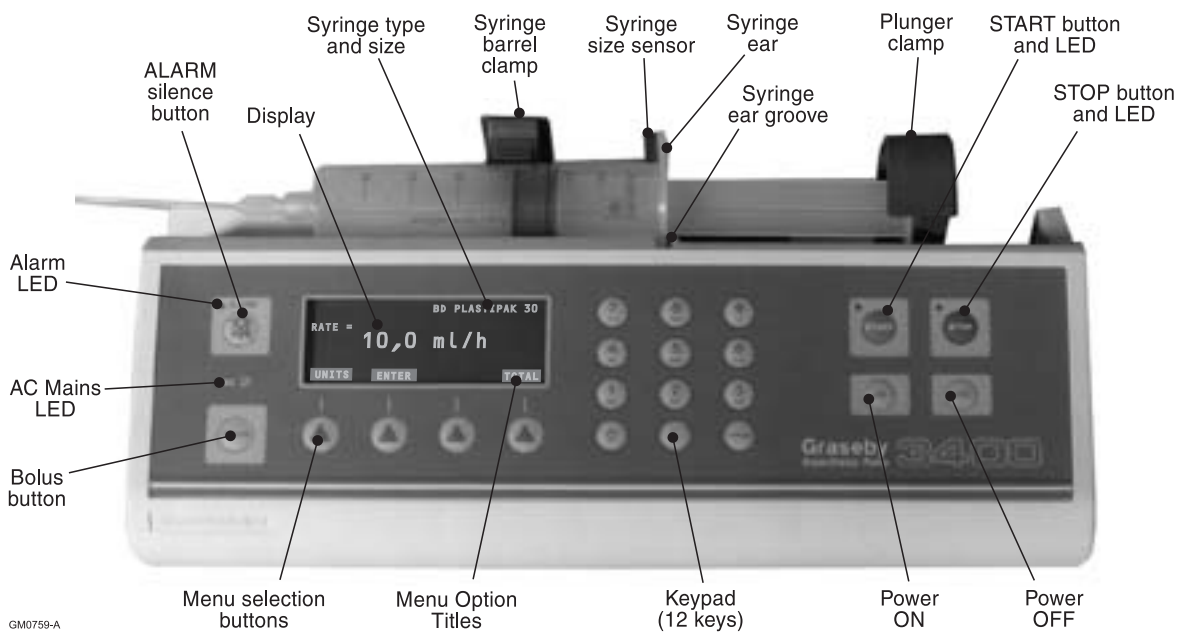

GM0759-A

Figure 1.1 Front view of the 3400 pump

Features

The main features of the 3400 are as follows:

- simple to use and easy to service,
- ergonomic styling,
- AC powered or internal battery powered,
- advanced safety features,
- a selection from several brands of syringe can be made, also the pump may be converted to work with the Braun Perfusor 50 ml syringe,
- automatic syringe size sensing,
- a clear text display,
- a comprehensive range of alarms. For example the pump gives a *Syringe Invalid* alarm; a syringe *Nearly Empty* alarm; etc.,
- designed in consultation with users.

Classification

The following classification information applies to the 3400, and is to the IEC 601-1:1988 requirement.

Insulation

The pump is a Class II (double insulated) device. Also classified as internally powered equipment.



Type CF (Cardiac Floating) insulation on all inputs.

Fluid ingress

IPX1. In the normal operating position the pump is protected against drops of water falling vertically onto it. It is not safe to use the pump in more severe wet conditions.

**Safety
(Caution)**

The pump is not suitable for use in the presence of inflammable anaesthetics mixture with air, with oxygen or nitrous oxide.

As with all computer electronic equipment, high powered electromagnetic radiation, such as diathermy equipment in close proximity, can affect operation, although no hazard will be caused.

**Mode of
operation**

Continuous.

Specification

Graseby pumps are subject to continual development and the 3400 may, therefore, differ slightly from the following specification:

Dimensions: 325 mm (long) x 195 mm (high) x 115 mm (deep) with the pole clamp fitted and the plunger clamp closed.

Weight: 3.5 kg including batteries and pole clamp.

AC supply: 100 to 240 V, 50/60 Hz, 40 VA. The power supply uses Primary Switching in order to utilise the AC supplies of most countries.

Battery type: Sealed lead acid, rechargeable (Cyclon, 3 off). SIMS Graseby recommend that the batteries are checked at least annually (see page 5-10).

Battery life: More than 10 hours of normal pump operation when the batteries are fully charged. With the AC supply connected, up to 14 hours will be required to fully recharge low voltage batteries.

Syringe brands:	BD Plastipak	5;10; 20; 30/35 or 50/60 ml.
	Terumo	5; 10; 20; 30/35 or 50/60 ml.
	Braun Omnifix	5;10; 20; 30/35 or 50/60 ml.
	Sherwood Monoject	5; 10; 20; 30/35 or 50/60 ml.
	IMS Pump-jet 30	30 ml (prefilled).
	Fresenius Injectomat	50 ml.
	Braun Perfusor	50 ml (conversion kit required, refer to Chapter 8).

Flow rate: Continuous; 0.1 to 400 ml/h in 0.1 ml increments.
Mass units; mg/kg/h etc.
Bolus; 0.1 to 1200 ml/h in 0.1 ml increments.

Totaliser: 0 to 999.9 ml in 0.1 ml increments.

Adjustable occlusion pressure: 1.85 kg (250 mm Hg) to 7.42 kg (1000 mm Hg).

Temperature range: Operating conditions:
+5° to +40°C, 30 to 75% Rh, 700 to 1060 hPa.

Storage conditions:
-40° to +70°C, 30 to 90% Rh, 700 to 1060 hPa.

Drive accuracy: ± 2% when measured over a complete syringe.

Design standards: IEC 601-1.

Elec. safety: Class II; Type CF.

Languages available: Selectable via the configuration mode (see page 2-2).

Brief history of SIMS Graseby bedside syringe pumps

MS2000

The first Graseby bedside syringe pump was the **MS2000**. This was a basic syringe pump capable of infusions within the range of 0.1ml/hr to 99.9ml/hr. It had a totaliser, a limited infusion capability, a built in pole clamp and was designed for vertical operation. The MS2000 was powered by an AC supply or its internal DC batteries. This pump is no longer manufactured by SIMS Graseby.

PCAS

The **PCAS** pump was developed from the MS2000 to satisfy the growing interest in Patient Controlled Analgesia (PCA). The PCAS was very similar to the MS2000 in both appearance and mechanical design, but utilised a different micro-processor with the capability of running the extra features required for PCA and was eventually replaced by the 3300 pump. A printer port was also incorporated. This pump is no longer manufactured by SIMS Graseby.

3000

The first pump in the 3000 Series of syringe pumps was the **3000** itself. This pump was designed as a low-cost alternative to the MS2000 and satisfied the need for a horizontally mounted pump. The 3000 did not have an internal battery supply. This pump is no longer manufactured by SIMS Graseby.

3100

The **3100** syringe pump was developed from the 3000. It is very similar mechanically but the electronic design is superior. Dual processors were incorporated along with a vacuum fluorescent text display and internal batteries. The maximum infusion rate was increased to 199.9 ml/hr and different syringe sizes were able to be used (automatically sensed). Extra software features, such as the intelligent 'near end' alarm, were also incorporated. This is the only pump in the 3000 Series that is **not** fitted with an RS232 connector.

3300

The next bedside syringe pump to be developed was the **3300**. This was similar in mechanical and electronic design to the 3100 but the features were specifically for the now more mature PCA market. A lockable syringe cover was added for security against drug theft, a four line LC display was added, and internal history recording (1500 events) with printout was also added. With the growth in PCA knowledge in the medical community, many more software features were incorporated into the 3300 to aid PCA administration.

3400

The **3400** was developed (again from the 3100) to satisfy the need for a high speed infusion pump for intravenous anaesthesia. Advances in micro-controller technology allowed the use of a single device to control all the pumps features. The maximum infusion rate was raised to 1200.0 ml/hr and bolusing facilities were also added. Later, an infusion rate calculation facility was added to the software.

A larger liquid crystal display was used on the 3400 with the ability to display text in different sizes, also 'soft-keys' were used to make the user interface simpler. The range of syringe sizes that could be used was also increased. For more advanced applications the pump could be controlled by a computer.

(contd.)

Brief history (contd.)**3200**

The 3200 was developed as a general purpose syringe pump. Wet-side pressure sensing, intermittent infusion capabilities, and computer interfacing were added. The wet-side occlusion pressure monitoring made the pump particularly suitable for use in intensive-care baby units. A large text vacuum fluorescent display was added, and the increased syringe size range of the 3400 remained.

A DC input supply (10 V to 28 V DC) version of the 3200 is also manufactured by SIMS Graseby. This variant is primarily intended for use in an aviation environment.

3500

There are two versions of the 3500, as follows:

1. A Manually Controlled Infusion (MCI) *only* pump.
2. An MCI *plus* a Target Controlled Infusion (TCI) pump.

The 3500 was developed from the 3400 and retains all the 3400 facilities.

The 'MCI *plus* TCI' pump carries out a TCI using the Diprivan drug. This version of the 3500 incorporates a Diprifusor module manufactured by Zeneca Pharmaceuticals. A new main circuit board and new software allows the 3500 to interface with the Diprifusor module.

A 3500 non- TCI pump can be converted to become a 3500 MCI *plus* TCI pump.

3150

The 3150 is very similar to the 3200 general purpose pump. The main difference being that the In-line (wet-side) pressure sensing system is **not** available on the 3150, i.e. the pressure transducer is not fitted.

CHAPTER 2

CONFIGURATION & DIAGNOSTICS MODE, AND THRUST ADJUSTMENTS

3400

ANAESTHESIA SYRINGE PUMP

CHAPTER 2

CONFIGURATION & DIAGNOSTIC MODE, AND THRUST ADJUSTMENTS

Configuration mode

WARNING

The Configuration Mode must only be used by personnel who have been appropriately trained in using the 3400.

The Configuration mode allows various parameters to be made available, which in turn allows various settings within these parameters to be set to the values required for the infusion.

The list shown below shows each parameter within the Configuration mode, and each parameter is further detailed in the sections that follow:

1. Syringe brand.
2. Display language.
3. Bolus beep.
4. Preset bolus.
5. Mass units.
6. LCD contrast.
7. Baud rate.
8. Max rate.

Calling up the Configuration mode

With the AC power connected and switched on (or under internal battery power) press the **ON** button. The pump will carry out its self tests and will then be in its 'set up' mode.

Press the second **▲** button from right and the **BOLUS** button simultaneously.
i.e. press **▲ ▲ ▲ ▲** and **BOLUS** simultaneously.

The display will show the following question:



Within two seconds press the **START** button to confirm that you want to enter the Configuration mode.

A display similar to the one shown below will then appear:

Note...

If the **START** button is not pressed within two seconds the pump will return to its 'set up' mode.

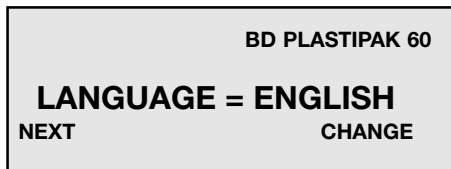
**Changing an option**

Press the **CHANGE** button repeatedly in order to scroll through the options that are available for each parameter. The displayed option will be retained when the **NEXT** menu button or the **STOP** button is pressed.

The various options are retained in non-volatile memory.

Moving to the next parameter

Press the **NEXT** button in order to move to the next parameter. If a new option is required repeat the above.

Press the **STOP** button at any option in order to exit from the Configuration mode and return to the 'set up' mode.

Configuration parameters and options that are available**Syringe brands****WARNING**

The pump must be set to operate and display the brand and size of syringe that is going to be used. Using a different brand or size of syringe to the one that is going to be used could lead to the incorrect amount of drug being administered, resulting in injury or death.

1. Options: BD Plastipak
Terumo
Braun Omnifix
Monoject
IMS Pump-jet 30
Injectomat 50 ml

Braun Perfusor: a conversion kit is required, see Chapter 8.

Display language	2. Option:	The optional display language required is selected by scrolling to it.
Bolus beep	3. Yes or No:	Set to YES if you wish the pump to beep whilst delivering a bolus. If a bolus beep is not required then set to NO .
Preset bolus dose	4. Yes or No:	Set to YES if you require the option to use the preset bolus (i.e. dose is preset for a Hands Free bolus infusion). Set to NO if the preset bolus is not required (i.e. the infusion dose is controlled by the user during the Hands On bolus infusion).
Mass units	5. Yes or No:	If the MASS UNITS parameter is set to YES then it will be possible to preset the pump to deliver an infusion in mass units, e.g. mg/kg/h etc. If the MASS UNITS is set to NO then ml/h will be the only selection available.
LCD contrast	6. Options:	The options available are 1 to 20.
Baud rate	7. Rate:	The rates available are... 300; 600; 1200; 2400; 4800 or 9600 Baud.
Max Rate	8. Options:	The MAX RATE options available are: 50; 100; 200; 400; 800 or 1200 ml/h. The software program automatically sets a maximum continuous infusion rate that depends upon the syringe size that the pump senses; see Table 1. This automatic continuous infusion rate will be overridden if the Configuration MAX RATE is set below the automatic rate. For example, even though the maximum continuous infusion rate for the BD Plastipak 50 ml syringe is 400 ml/h (see Table 2.1), if the Configuration MAX RATE is set to, say, 200 ml/h then the syringe will only be able to infuse at up to 200 ml/h. Thus the Configuration MAX RATE setting can be used to control, in preset steps, both the continuous infusion (up to 400 ml/h) and the bolus infusion (up to 1200 ml/h).

Table 2.1 Syringe size and maximum automatic continuous infusion rate

Syringe size	Max. auto. cont. infusion rate (ml/h)
50/60	400
30/35	400
20	400
10	200
5	100

Diagnostic mode**WARNING**

The Diagnostic mode must only be used by appropriately qualified personnel.

The 3400 has been designed so that the Diagnostic mode parameters will only be available if a set sequence of pump buttons are pressed.

Calling up the Diagnostic mode

With the AC power connected and switched on (or under internal battery power) press the **ON** button. The pump will carry out its self tests and will then be in its 'set up' mode.

Press the second ▲ button from right, and the **ALARM** button simultaneously.
i.e. press ▲ ▲ ▲ ▲ and the **ALARM** button simultaneously.

The display will show the following question:

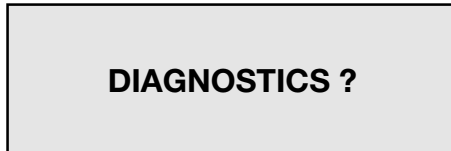

Within two seconds press the **START** button to confirm that you want to enter the Diagnostic mode.

A display similar to the one shown below will then appear:

Note...

If the **START** button is not pressed within two seconds the pump will return to its 'set up' mode.

**Moving to next parameter**

Press the **NEXT** button in order to move to the next parameter.

Diagnostic displays

The five parameters that can be viewed, by scrolling when in the Diagnostic mode, will be similar to the displays shown below:

- **VERSION = 2.06**
this display shows the version of software that is installed in the pump. Note, since the 3400 is field up-gradable via its serial port the version number on the label of the EPROM may differ from the installed version. The displayed version is to be taken as correct.
- **CRC = CD53**
this shows the Cyclic Redundancy Check (CRC).
- **TOTAL VOLUME**
this shows the total volume infused since the pump was manufactured.
- **TOTAL HOURS**
this shows the total hours that the pump has been in operation since the pump was manufactured.
- **VOLTAGE = 6.9**
this shows the value of the DC voltage that is supplied to the main board.

Exiting from the Diagnostic mode Press the **STOP** button when in any Diagnostic parameter in order to exit from the Diagnostic mode.

Disassembly and assembly of casing

WARNINGS

The following procedures must only be carried out by qualified personnel.

Electric shock hazard

The pump *must* be disconnected from the AC power supply before opening the casing.

Taking the casing apart

The casing of the pump will have to be opened in order to carry out any adjustments that may be required to the occlusion thrust, and also for various setting up and repair procedures. These procedures are detailed in Chapters 4 and 5.

1. Disconnect the AC power connector and utilising a scratch free flat surface, turn the pump over in order to gain access to the base of the pump.
2. Undo and retain the six screws that hold the two halves of the pump casing together. One of the six screws is situated in a channel in the rear cover.
3. Place the pump upright and from the top carefully ease the two halves of the casing apart, taking care not to put any strain on the internal connecting cable looms that form a hinge between the two halves of the casing.

Assembly

1. Each time the casing has been taken apart and reassembled the syringe size functional tests detailed on page 6-1 must be carried out.
2. Being careful not to trap any leads, assemble the casing by reversing steps 2 and 3 detailed above, ensuring that the two case halves have 'snapped' together and that the front and rear mating edges are equal and parallel. The screws should be tightened to a torque of between 70 and 75 cNm, and in the order shown in the diagram below:

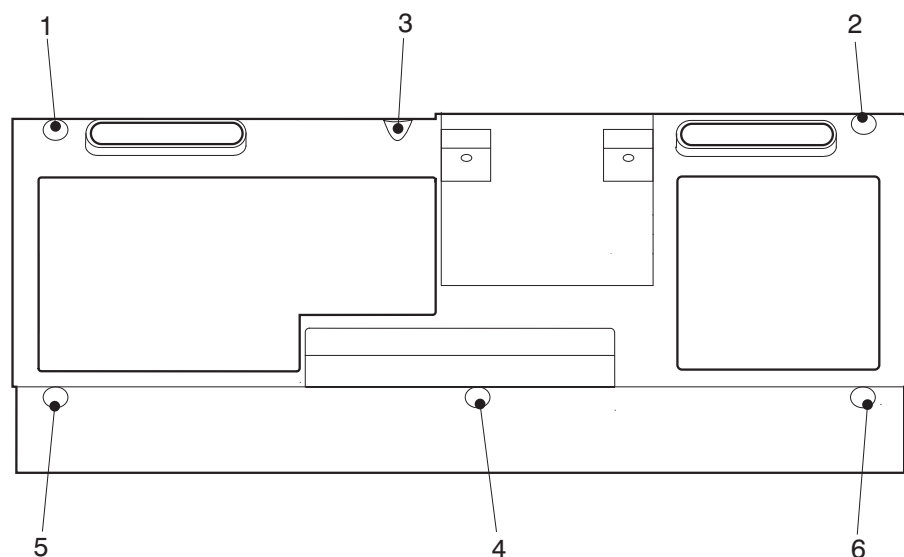

GM0595-B

Occlusion measurements

The two most frequently used methods to measure the point at which an occlusion occurs are the **thrust** and **pressure** methods.

At the present time SIMS Graseby set the occlusion by using a **thrust** measurement procedure. This method measures the plunger clamp thrust by using a set of weights (as described below), but has the slight disadvantage that the characteristics of the syringe have to be taken into account.

The occlusion **pressure** is obtained by measuring the pressure that occurs in the infusion line. This in-line method gives a good accuracy (better than 5%) over a wide range of pressures, but also has the slight disadvantage of requiring a disposable that is unique to the pump being measured.

The internal occlusion sensing system within the pump is always active.

The occlusion thrust checks must be carried out whenever the super nut assembly is dismantled.

Thrust measurements

Translation of the thrust depends on the syringe diameter and the stiction of the syringe. The formula for calculating the thrust is given below:

$$T = \frac{P \times A}{732} + S$$

where: T is the thrust in kg,
 P is the delivery pressure in mmHg,
 A is the cross sectional area of the syringe in cm²,
 and S is the syringe stiction in kg.

The occlusion thrust of the pump is factory set to be between two limits (i.e. a minimum and a maximum tolerance). The customer may reset the thrust for their own particular requirement. The thrust of a particular pump may, therefore, differ from the original factory set level.

The occlusion thrust of the **3400** pump is factory set at Graseby's to be between 5.7 kg and 6.2 kg (767 mmHg and 834 mmHg).

Syringe stiction

Stiction for a syringe varies from brand to brand as well as from batch to batch. Stiction can be as low as 0.1 kg and as high as 2 kg. The stiction of some syringe brands has been found to be particularly high.

Stiction can also vary along the plunger travel and is usually lowest in small diameter syringes. Using a sample syringe and allowing for a safety margin for sticky syringes, adjustments can be made by measuring the thrust generated. If the stiction characteristics of a syringe are known then by using the formula given above the occlusion thrust can be set.

Thrust checks

The thrust checks that are detailed below use the weights that correspond to the factory set occlusion threshold levels for a 3400 (i.e. 5.7 and 6.2 kg). If a different occlusion level setting is required then the weights will have to be adjusted accordingly.

The thrust adjustment procedures are detailed on page 2-8.

1. Set the pump's plunger clamp to approximately midway along its support tube.
2. Remove the plunger from a BD 60 ml syringe and then saw the end off the syringe (see Fig. 2.1). Place this modified syringe onto the pump so that it will act as a guide for the weight support rod and also position the size sensor flag.
3. With the pump switched **ON**, set the infusion rate to 200 ml/hr.
4. Place the pump in a vertical position, with its left hand side uppermost (see Fig. 2.1).
5. Place the weight support rod through the modified syringe and onto the pump's plunger clamp.
6. Place a weight of 5.7 kg on top of the weight support and check that the pump operates for at least 30 seconds and does **not** occlude (i.e. the alarm does not sound). Remove the weight.
7. Place a weight of 6.2 kg on top of the weight support and check that within 30 seconds the pump does occlude (i.e. the alarm sounds).

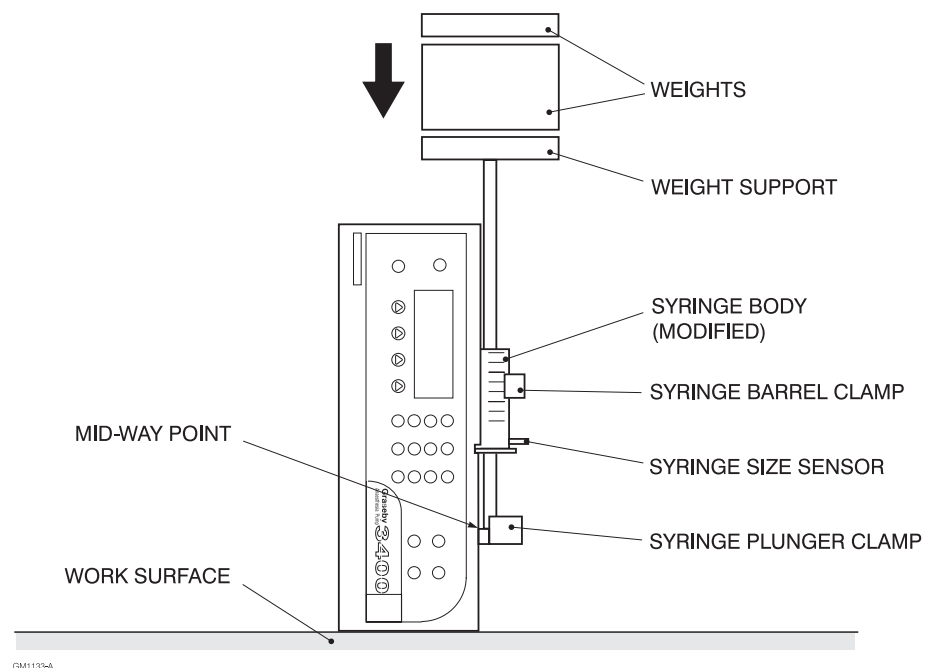

Figure 2.1 Thrust measuring set up

Thrust adjustments

If the occlusion thrust requires adjustment then the following procedures will have to be carried out:

1. Switch the pump off and disconnect the AC supply.
2. Take the casing apart as detailed on page 2-5.
3. If necessary rotate the leadscrew to reveal the grub screw that is located on the occlusion adjusting nut. Loosen the grub screw with a 1.5 mm hexagonal key.
4. Alter the setting of the occlusion adjusting nut as necessary. One full turn of the adjusting nut using a 50\60 ml syringe gives approximately 2.73 kg (369 mmHg) of adjustment.

Rotating the adjusting nut in order to decrease the tension on the leadscrew spring will decrease the pump's occlusion setting.

Rotating the adjusting nut in order to increase the tension on the leadscrew spring will increase the pump's occlusion setting.

5. Tighten the grub screw.
6. Temporarily assemble the two halves of the pump, being careful not to trap any leads.
7. Carry out the thrust checks detailed on page 2-7.
8. In order to obtain the thrust required it may be necessary to repeat steps 2 to 7 above.
9. Finalise the assembly of the pump casing (see page 2-5).
10. Carry out tests No 9 and 10 detailed in the functional test procedures (see page 6-3).

CHAPTER 3
FUNCTIONAL DESCRIPTIONS

3400
ANAESTHESIA SYRINGE PUMP

CHAPTER 3

FUNCTIONAL DESCRIPTIONS

Introduction

This Chapter explains how the 3400 operates. Reading this chapter will help a technician to rectify any possible faults that may occur within the pump.

The functional descriptions of the pump may be divided into five separate areas, and each of these functional descriptions have been detailed separately in the descriptions that follow:

- Drive system.
- Occlusion sensing system.
- Electro/mechanical control system.
- Sensing (alarm) systems.
- Software.

Drive system

The motor, gearbox, leadscrew and associated components (see Fig. 7.1) are mounted on a glass reinforced polycarbonate casing. The strength of this casing enables a precise mechanical location to be achieved for the various components.

Both the inner and outer metal tubes are made of substantial material in order to eliminate all unwanted flexing.

DC motor and leadscrew

The drive system comprises a DC motor working through a gearbox in order to rotate a leadscrew. A half nut assembly engages onto the leadscrew, and the assembly is also connected to a steel tube. The steel tube is in turn connected to the plunger clamp.

As the motor spindle rotates the *leadscrew* rotates and the *half nut assembly* travels to the left, along the *leadscrew*. The *half nut assembly* pulls the outer of two steel tubes to the left. This outer tube travels over and along a support tube; the support tube is the length of the pump. The plunger clamp moves with the outer tube pushing 'in' the syringe plunger.

Processor

The DC voltage applied to the motor is derived from a pulse width modulated output from the processor.

Toggle mechanism

A spring-loaded toggle mechanism is attached to the bottom of the half nut. This toggle mechanism enables the plunger clamp to be physically swung 'in or out' thus rotating the outer metal tube so that the half nut is either fully 'engaged or disengaged' (respectively) from the leadscrew.

Plunger clamp

When the plunger clamp is pulled down the *half nut* engages with the *leadscrew*, and the clamp itself engages with the end of the syringe.

The syringe plunger slots into place behind a slotted pair of lips. These lips prevent the syringe plunger from moving forward in the event of negative pressure on the syringe.

Two small push-buttons on the edge of the plunger clamp make contact with the top of the syringe plunger. These push-buttons control the operation of a *lever* which protrudes from the plunger clamp.

When the push-buttons are pressed in, by coming into contact with the top of the syringe, the *lever* becomes free and is able to retract into the plunger clamp. This retraction takes place when the plunger clamp is physically swung into its down operating position.

If the push-buttons are not pressed 'in' the *lever* will be locked in its protruding position thus preventing the plunger clamp from being pulled down. This in turn prevents the *half nut* from engaging on the *leadscrew*.

This push-button safety system prevents the *leadscrew* from being engaged unless the top of the syringe is correctly positioned in the plunger clamp.

If the plunger clamp is accidentally dislodged during an infusion the pump will stop infusing and the alarm will sound.

Occlusion sensing system

Clutch assembly and opto-sensor

The occlusion sensing system consists of a clutch, spring mechanism, a rotating slotted disk and opto OPTO1 (see page 4-27). The clutch and spring mechanism comprise the back pressure system. The rotating slotted disc and OPTO1 comprise the rotation detector. The clutch, slotted disc and OPTO1 are located at the left hand end of the leadscrew, underneath the opto sensor board. The spring is located at the right hand end of the leadscrew.

The clutch is held engaged by the spring with a pressure sufficient to overcome any resistance from the syringe plunger and the normal back pressure from the infusion line. The rotation detector will generate an output that comprises a continuous set of pulses when the leadscrew rotates.

Occlusion detection

If there is an occlusion in the line then the back pressure will rise as the pump attempts to force fluid through the line. When there is sufficient pressure to overcome the spring pressure (factory set at 800 mm Hg) then the leadscrew moves to the right, losing contact with the clutch. The rotation detector no longer generates an output which results in an occlusion alarm.

This method of occlusion detection is extremely sensitive as it is the lack of pressure on the clutch that generates the alarm, rather than the detection of the movement of the leadscrew as used in traditional designs. UK patent number 2249 497.

Electro/mechanical control system

Motor speed

The processor outputs a Pulse Width Modulated (PWM) signal which has a mark-space ratio proportional to the required speed of the DC motor. The motor interface circuit outputs a DC voltage which is varied by the PWM signal.

Motor rotation

A Hall effect sensor is attached to the motor shaft and is used to provide a feedback signal. This feedback signal enables the processor to change the PWM signal, thus altering the speed of the motor.

Rotation of the occlusion slotted disc described above is also used in conjunction with a second sensor, to monitor the rotation of the motor. If either sensor does *not* detect the appropriate pulses an alarm signal will be generated.

Mechanical characteristics

The mechanical characteristics of the system are:

- Gearbox reduction ratio: 150:1.
- Leadscrew pitch: 1.587 mm.
- Syringe characteristic: 1 ml/1.8 mm (BD 60 ml syringe).

Sensing (alarm) systems

Introduction In addition to the occlusion sensing system (see page 3-2) the following sensing systems are also operative within the 3400.

Syringe nearly empty A metal flag protrudes from the left hand side of the half nut (in parallel with the leadscrew), this is the nearly empty flag. When this flag de-activates OPTO 0 (see page 4-27) that is situated at the left hand side of the leadscrew, and the slotted disc is still rotating, then the processor makes a calculation that depends on the infusion rate, and issues an alarm three minutes before the end of the infusion.

Also, when the processor detects that OPTO 0 is de-activated, and the slotted disc has also stopped rotating, then an OCCLUSION alarm is generated.

End of infusion/occlusion Although the above condition has been termed an alarm state, the same conditions will occur when the syringe reaches the end of its travel at the end of a perfectly normal infusion.

If the slotted disc stops rotating and the nearly-empty flag has **not** moved a sufficient distance to the left to de-activate OPTO 0 then the alarm condition will be that of occlusion, as explained on page 3-2.

AC power failure The software sensing system will detect an AC power failure. The pump will continue to run after a power failure for a period of ten hours or more, by automatically switching to the internal battery supply.

Battery voltage low The sensing circuits incorporate a system that monitors the output of the batteries and registers an alarm if the voltage of the batteries drops below 5.75 V. If the voltage falls below 5.4 V the pump will turn itself off after an initial warning period.

Self tests, pump malfunction Various 'self tests' are carried out on the pump when it is first switched on. In addition to the self tests the rotation of the slotted disc at the end of the leadscrew is monitored to ensure that the drive mechanism is operating correctly.

Drive disengaged, or syringe not fitted The drive system is designed so that it is only engaged when the top of the syringe is correctly positioned in the plunger clamp. If the plunger clamp is knocked out of place during an infusion the drive will automatically stop (the disengagement of the half nut is detected by an opto-sensor).

Also, trying to operate the pump without a syringe or with a syringe incorrectly fitted will cause the pump to go into an alarm state.

Syringe sizing system The syringe sizing system comprises a flag moulding (see Fig. 7.2) that rests on the barrel of the syringe, and in conjunction with three size sensors (see Fig. 7.6) measures the diameter of the syringe being used.

The flag moulding rotates about the outer of the two guiding tubes and moves an actuating flag between the three size sensors.

The flag is able to 'de-activate' the three size sensors in any one of the following combinations:

none; 1; 1-2; 1-2-3; 2-3 or 3.

Depending on the operation of the size sensors the pump monitors the size of a syringe as being 5 ml, 10 ml, 20 ml, 30 ml or 50/60 ml.

Or alternatively, if a syringe is not fitted or a syringe smaller than 5 ml is fitted, then the

SYRINGE INVALID

alarm will be activated.

Software**Design methods**

The software for the pump has been designed using the structured design methods. The software incorporates many safety tests and consistency checks. The source code for the processor is written in Modula 2 which is particularly suitable for safety-critical design.

Self tests

The self tests include the following:

- CPU test.
- ROM test (16 bit CRC).
- RAM test.
- Power supply voltage test.
- Keyboard test. This test checks for shorted keys.

The pump's settings are stored in EEPROM in the processor.

CHAPTER 4
CIRCUIT DESCRIPTIONS

3400
ANAESTHESIA SYRINGE PUMP

CHAPTER 4

CIRCUIT DESCRIPTIONS

Introduction

This Chapter describes the action of the circuits that are used to operate the 3400 and also shows the associated circuit diagrams and circuit board layouts.

The 3400 contains five separate circuit boards, as follows:

- Main board.
- Regulator board.
- Syringe size sensors board.
- Opto-sensors board.
- Umbilical board.

The overall block diagram for the 3400, showing the inter-connections between the various circuits is given in Fig. 4.1.

The Syringe size sensors board (Fig. 4.16 and 4.17) and the Opto-sensors board (Fig. 4.18 and 4.19) provide a mounting base for the sensors and also junction points for their outputs.

The Umbilical board (rear casing) is used to link the Regulator board, the two Sensor boards, and the serial interface port to the Main board (front casing) via a 26 way cable (Fig. 7.1).

The five circuits are individually described in the sections that follow.

Main board circuit

Sub-circuits The Main board circuit is shown in Fig. 4.2 and comprises the following sub-circuits. These sub-circuits are individually described in the sections that follow:

- Processor core.
- Motor interface.
- Power control.
- Sensors interface.
- Communications (RS232) interface.
- Input/output interface.

Processor core circuit

Description The Processor core circuit (Fig. 4.3) forms part of the Main board circuit and is used to process all the 'operating' activities of the pump.

The processor (IC12) has an on-chip EEPROM which stores the latest settings of the pump, e.g. the syringe brand.

IC12 also incorporates the following:

- On-board RAM.
- An Analogue-to-Digital converter (A to D).
- Timing circuitry.
- Four pulse width modulated outputs.
- Communications circuitry.
- An internal watchdog.

IC9 is a 512 kbyte flash EPROM device which is addressed by the processor's decode logic as 16 pages of 32k each. A small portion of the EPROM device is reserved by the system for a bootloader program which is capable of programming the rest of the device from data supplied via the pump's RS232 interface. The remainder of the device stores the pump's system software. The entire pump operating software may be reprogrammed via the RS232 port.

Pins 70 and 71 on IC12 control the operation of the processor and both signals are held high in order to set the processor to address IC9 for its operating software.

Pins 44 and 43 on IC12 are held at Vcc and ground (respectively) as the reference inputs to the processor's built in A to D converter.

The chip IC10 is the processor's supervisory circuit, which has the four following main duties:

- to control the processor reset,
- to provide the switch over battery backup for the RAM,
- to provide the watchdog timer,
- to provide the CMOS RAM write protection during power down.

Pin 21 of the processor receives pseudo non-maskable interrupts generated by the supervisory circuit in the event of a system fault being detected.

The crystal X1 and the associated components R63, C28 and C29 form a 16 MHz oscillator to provide clock pulses for the processor, via pins 67 and 68.

The ram chip (IC8) is used as a buffer for the RS232 interface and the display, and general purpose storage area.

A Pulse Width Modulated (PWM) output on pin 12 (PW1) is used to control the DC motor power.

Output PW3 on pin 14 controls the sounder.

Output PW4 on pin 15 controls the LCD screen contrast.

Motor interface circuit

Introduction

IC12 utilizes a closed loop power controlled system to regulate the speed of the DC motor. A Pulse Width Modulated output signal (PW1; pin 12; Motor Drive) is used for this regulation. This system results in very accurate control over the rate that the drug is administered.

Power control transistors Q11 and Q12 (Fig. 4-4) in conjunction with resistors R33, R36 and R37 allows the 5 V PW1 signal to control the 7 V supply (DCSW).

Thus supply DCSW is switched on and off by the power control circuit. R42 protects the power supply from short circuiting if Q11 and Q12 are both active at the same time.

The motor windings are connected to Vin, so the transistor Q8A will be activated by the presence of the signal ENABLE_MOTOR. For the motor to run, Q8A must be active, thus making a motor circuit interlock.

The 7 V DCSW PWM signal provides the inputs to Mosfet's Q10A and Q10B. These two power Mosfet's when conducting enable the motor to draw a high PWM current from the 7 V DC supply (Vin).

Transients, suppression

L2 and C17 smooth the high PWM current to a level that is acceptable for motor operation. Reservoir capacitor C21 reduces excessive peaks on Vin. C18 prevents transients from DCSW affecting the operation of Q11 and Q12.

Motor speed control

To close the control loop, the motor speed is monitored by a hall effect sensor on the back of the motor shaft. The signal is detected by R41, R40, R74, and IC15F before being fed back to the processor.

IC12 measures the frequency of this feedback signal and if the signal is outside the limits required for the speed of rotation, then IC12 will change the duty cycle of the PWM output.

By using this feedback system the speed of the motor can be closely controlled to within set limits.

Power control circuit

Logic circuit supply, Vcc

Chip IC4 (Fig. 4.5) is a linear regulator which provides a 5 V DC supply (Vcc) for the logic circuits. C14 and C10 are decoupling capacitors.

IC5B and IC5C form a set/reset latch to operate the power MOSFET Q8B. The latch is triggered by a high pulse (POWEROFF) from the processor, causing Q8B to turn off and disconnect the power.

When tripped, the latch cannot be reset by the processor; the reset is by a high pulse from the keyboard by pressing the **ON** button.

Q7, R28 and R29 form a logic level translator to raise the 0 to 5 V logic levels to 0 to 7 V logic levels for IC5C, which has a permanent 7 V supply.

C15, C16, R28 and R30 overcome the effects of any transients.

D19 prevents C16 from discharging into IC5B in the event of Vdd being removed.

RAM and clock supply

The supervisor chip (IC10) transfers the power for the RAM and the Real Time Clock (RTC) from the regulated 5 V supply Vcc to Vcc' when the main power, and hence Vcc, is turned off. This preserves the memory held in RAM and also keeps the RTC running.

R31; R26 and C11; bandgap references D20 and D21; and transistor Q6, supply a constant voltage, Vcc', of 3 V.

Sensors interface circuit

Introduction

The six opto-sensors (Fig. 4.16 and 4.18) used in the 3400 are multiplexed onto three lines into the processor and are used to carry out sensing functions that include the following:

- syringe size sensing,
- whether the syringe clamp is open or closed,
- the rotation of the slotted disc used for detecting an occlusion,
- if the syringe is nearly empty.

The syringe size sensors board and the opto (status) sensors board are detailed on page 4-9.

Circuit description

Q14 (Fig. 4.6) activates the size sensors LEDs.

Q15 activates the opto (status) sensors LEDs.

The software determines which of the two transistors is active at a given time. R59; R60; R61 and R62 are current limiting resistors.

The opto-detection circuit uses R56 to R58 as pull-up resistors, and uses R52A to R52D; R53 and R54 as current limiting resistors.

Zener diodes D22 to D24 are used for electrostatic discharge protection.

When a photo transistor detects the LED associated with it, the line OPTO_0; 1; or 2 will be pulled low, this signal is then input to the processor via SENSE1; 2; or 3 (respectively).

When SENSE0 is low it indicates that the mains supply is present. R50; R51; R55 and Q13 enable the processor to detect the presence or absence of the AC supply.

R48; R49 and C27 act as the low battery voltage sensing circuit. R48 and R49 act as a potential divider enabling the voltage between them to be input to the A to D converter on the processor.

RS232 Interface circuit

- Warning** Only items of equipment that conform to EN60950 may be connected to the 9-pin RS232 connector that is situated at the rear of the pump. This conformity will prevent the safety of the patient being compromised.
- Circuit description** The processor generates an RS232 compatible signal, with a 0 to 5 V output. Chip IC7 (Fig. 4.7) together with the components L3; R47; C22 to C26 converts this 0 to 5 V input signal into two higher level outputs; +10 and -10 V.
- IC7 is supplied with a single +5 V power rail, and uses two charge pumps to create a +10 and a -10 V supply.
- The communications protocol description may be obtained from Graseby Medical (Customer Care).
- The signals on the 'D' connector are shown on Fig. 4.22, and the pin connections for the 'D' connector are shown below:

Table 4.1 RS232 'D' connector connections

Pin No.	Connection
1	Not connected
2	RxD
3	TxD
4	Not connected
5	GND
6	DSR (handshake out)
7	RTS (+10 V out)
8	CTS (handshake in)
9	Not connected

Input/output circuit

- Front panel interface** The user interface is via the 22 button membrane front panel.
- Pressing the **ON** button completes the circuit between pins 1 and 2 on PL2 (Fig. 4.8) and resets the latch that switches the DC power on.
- The remaining buttons use a 6 x 4 matrix.
- The 6 matrix rows, on pins 3 to 8 of PL2 (inclusive) are pulled *high* by resistors R14B; R14D; R15B; R15D; R16B and R16D and each row is connected to a membrane button and also to the microprocessor.
- The four columns of the matrix, pins 9 to 12 on PL2 (inclusive), are connected to IC1, the parallel out serial register. As each column is pulled *low*, the status of each button in that column is input to the processor.

R22 limits the current in the control lines out of IC1. Diodes D8 to D11 allow IC1 to pull the selected control line low, but let the remaining lines float when a logic high is applied at the output of IC1. Zener diodes D13 to D18 (inclusive) and resistors R14A; R14C; R15A; R15C; R16A and R16C form the electrostatic discharge protection circuit.

LED illumination

The other four output lines on IC1 are used to activate transistors Q1; Q2; Q3 and Q5. Q1 to Q3 control the illumination of the display LEDs D2, D3 and D4.

Q5 with associated components D5, D6, R11 and R4 sinks a constant current from pin 18 on LCD1, thus illuminating the LED used to backlight the LCD display.

LED D1 is lit when there is a voltage on VAC, which signifies that the AC supply is connected.

Real time clock

IC3D acts as an inverter to input IO_CLR so that IC1 has its outputs disabled when the real time clock (IC11; Fig. 4-3) is reading data to or from the processor: IC1 and IC11 share the same data lines.

Liquid crystal display

The 192 x 64 pixel, dot matrix liquid crystal display, is made up of three sections controlled by three drivers. Which driver is used for the data lines DB0 to DB7, on the data bus in LCD1, is controlled by the signals DISPLAY 11 to 13 from the processor.

DISPLAY 11, which is connected to pin 16 on the processor, is the master display enable line. DISPLAY 12 and 13 define the section to be activated.

The contrast of the display is controlled by the voltage on pin 5 of LCD1. This voltage is produced by the inverting switching regulator, IC2.

The feedback reference voltage used by IC2 is varied by filtering the CONTRAST signal, a PWM output from the processor, this allows the contrast to be set by the user when in the configuration mode. Thermistor RT1 compensates for fluctuations to the display contrast, due to temperature changes.

Sounder

The supervisor chip IC10 (Fig. 4.3) is able to turn on the sounder independently of the processor by using the DIRECT_SOUND signal. The sounder is turned on if the processor malfunctions and is unable to produce its own sounder control.

The above is achieved by the watchdog on IC10 producing a timeout, thus generating a DIRECT_SOUND control. D12 prevents a low signal from the SOUND signal drawing a current from IC10.

Q4 and the associated components C3, R6, R12 and R17 constitute a low pass filter which allows the PWM signal (SOUND) from the processor, to activate the sounder. The sounder is connected to plug PL1.

Regulator board circuit

- Introduction** The 3400 utilizes a primary switching power supply, as shown on Figures 4.11, 4.12 and 4.13, thus allowing the pump to operate with an AC input voltage between 100 V and 250 V.
- The advantages of this type of power supply over a conventional power supply include the following:
- greater efficiency,
 - larger power capability for a given size of power supply,
 - a smaller transformer is needed for a given output power.
- The operation of the Regulator is based upon a universal switch mode controller, IC1 (Fig. 4.12), which uses current mode pulse width modulation control.
- The Regulator provides the following DC supplies:
- 7 V for the motor supply and the LEDs, and
 - 5 V for the logic circuits.
- Live circuit and T1 primary description** The AC input supply is applied to the live circuit (i.e. the primary side of T1) via protection fuse FS2 (500 mA; Fig. 4.13) to the filter R20 and L2. The output from bridge rectifier D7 is smoothed by C10, and the transient current is limited by varistor V1.
- When V1 is cold the resistance is high, and as the thermistor warms up the resistance decreases allowing the current to increase. The resulting output is used to start up IC1 via pin 1, and is also fed to the primary winding (pin 6) of the power transformer.
- Once the switch mode controller has been started it obtains its supply from the bootstrap winding of T1, pins 2 and 3. This supply is smoothed by C13 and regulated by Zener diode D6.
- The PWM signal output from pin 5 on IC1 controls the operation of Q3, which cycles on-and-off thus regulating the flow of current through the primary winding of T1, connected between OUT1 and OUT2.
- Transient suppression is applied (Fig. 4.11) by C1/R1; C2/R2; C3/R4 and C4/R3.
- T1 secondary** The voltage at the secondary of T1 is rectified and smoothed (D1, D3, C6 and C7; Fig. 4.13).
- The DC outputs are protected by fuses FS1 and FS2.
- Batteries circuit** When the AC supply is being used there will be a DC voltage on pin 4 of PL11, thus allowing R6 and R7 to act as a potential divider in order to control Q2. Q2 will not be active if the AC supply is not present, this prevents the batteries from discharging through R8, R9, RV1 and R10.
- When Q2 is active, the above components form a potential divider between the output of D3 and 0V. The output from the potential divider is used as the reference voltage for the shunt regulator D4.

C8 is a transient suppressor. Thermistor TH1 varies the reference voltage according to temperature, thus compensating for battery charging characteristics.

When the voltage at potentiometer RV1 exceeds the reference value, D4 conducts and activates the opto-coupler, IC2 (Fig. 4.11), and the current through this photo-transistor causes a voltage to be developed across resistor R19. This voltage is applied to IC1, which changes the mark-space ratio of the output signal (pin 5).

Overvoltage protection

The Regulator is safeguarded from an overvoltage by a crowbar protection device. When the output voltage exceeds 13 V the Zener diode D2 conducts, thus causing a voltage to be developed across R5. This voltage is used to activate the silicon controlled rectifier Q1, which will sink enough current to result in fuse FS1 blowing.

Plug PL11 outputs

The outputs at plug PL11 should be as follows:

Pin	Output
1 and 2	Ground
3	7 V DC when on AC or battery supply
4	7 V DC when on AC supply

Setting RV1

The procedure for setting RV1 is as follows:

1. Switch off the external AC power, remove the AC power connector and open the casing as detailed on page 2-5.
2. Remove plug PL11 and PL12 from the Regulator board and connect a 68 ohm, 1 watt resistive load across pins 2 and 3 of plug PL11. Pin 1 of PL11 is the top pin, as shown on the Regulator component layout diagram, Fig. 4.15.

Note: A Molex connector (part number 3750-7217) will enable the 68 ohm resistor to be easily connected across PL11.

WARNING

During the setting of RV1 dangerous AC supply voltages will be present.

3. Connect and switch on the AC power. If necessary, adjust RV1 to give a DC voltage across the 68 ohm load, dependent on the temperature, as shown in Table 4.2. RV1 is located near the bottom left hand corner of the board (see Fig. 4.15).

Table 4.2 Temperature/voltage range for setting RV1

Ambient temperature (°c)	DC output voltage (68 ohm load)
28	7.015
27	7.027
26	7.038
25	7.050
24	7.062
23	7.073
22	7.085
21	7.096
20	7.108
19	7.120
18	7.131
17	7.143
16	7.154
15	7.166

4. Switch off the AC power; remove the 68 ohm load; reconnect PL11 and PL12 to the Regulator board and assemble the casing as detailed on page 2-5.

Size sensors and board

The Syringe size sensors board (Fig. 4.17) is located just in front of the right hand end of the leadscrew (Fig. 7.1). The sensor moulding houses three infra-red emitting diodes and three photo-transistors.

These three pairs of detection sensors (Fig. 4.16) are used to detect and monitor the size of the syringe that is fitted onto the pump.

The ribbon cable from PL1 connections on the Size sensors board is routed to plug PL7 on the Distribution board.

Opto sensors and board

The Opto (status) sensors board (Fig. 4.19) is located on the left hand side of the pump, just above the left hand end of the leadscrew (Fig. 7.1). There are three optical interrupt devices attached to this board.

The three optical sensors (Fig. 4.18), opto interrupter 00, 01 and 02, are used to monitor the status of the three following parameters:

- end of syringe travel detection,
- occlusion detection,
- drive engagement detection (half nut on/off leadscrew).

The sensors are hardwired from plug PL1, on the Opto sensors board, via a ribbon cable to plug PL3 on the Distribution board.

Umbilical board connections

The Umbilical board (Fig. 4.10) routes data between each of the other boards within the pump, and transfers this data to the umbilical ribbon cable connector.

Umbilical cable connector

The umbilical ribbon cable connector (Fig.4.9) enables data, and the circuit power supplies, to be sent between the Main board and the Umbilical board. The Umbilical board is situated on the rear case moulding.

This method of design means that only the ribbon cable and the batteries connector link the two case halves, thus facilitating, when required, ease of servicing.

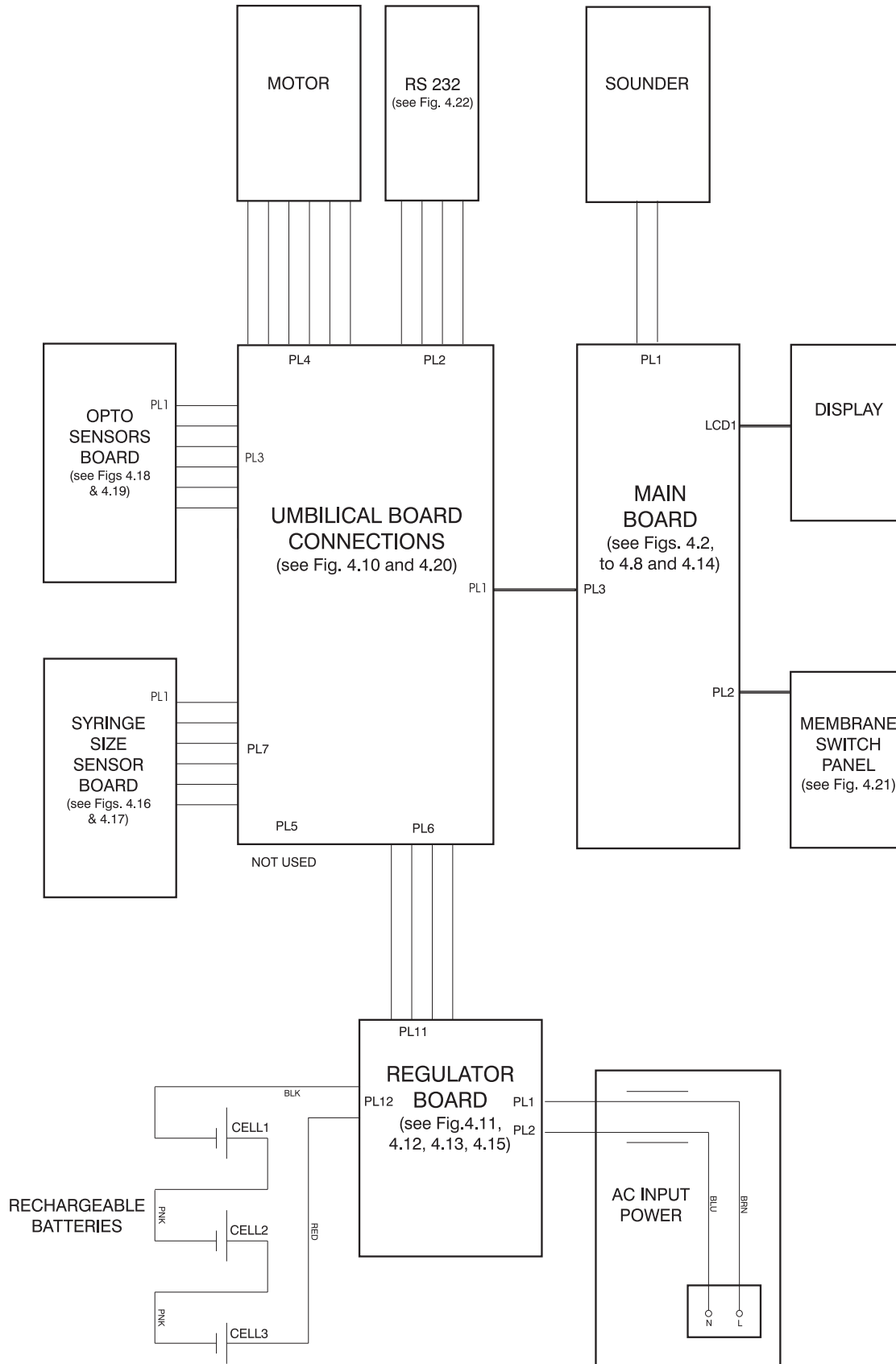

GM1120-A

Figure 4.1 Overall block diagram of the 3400 system

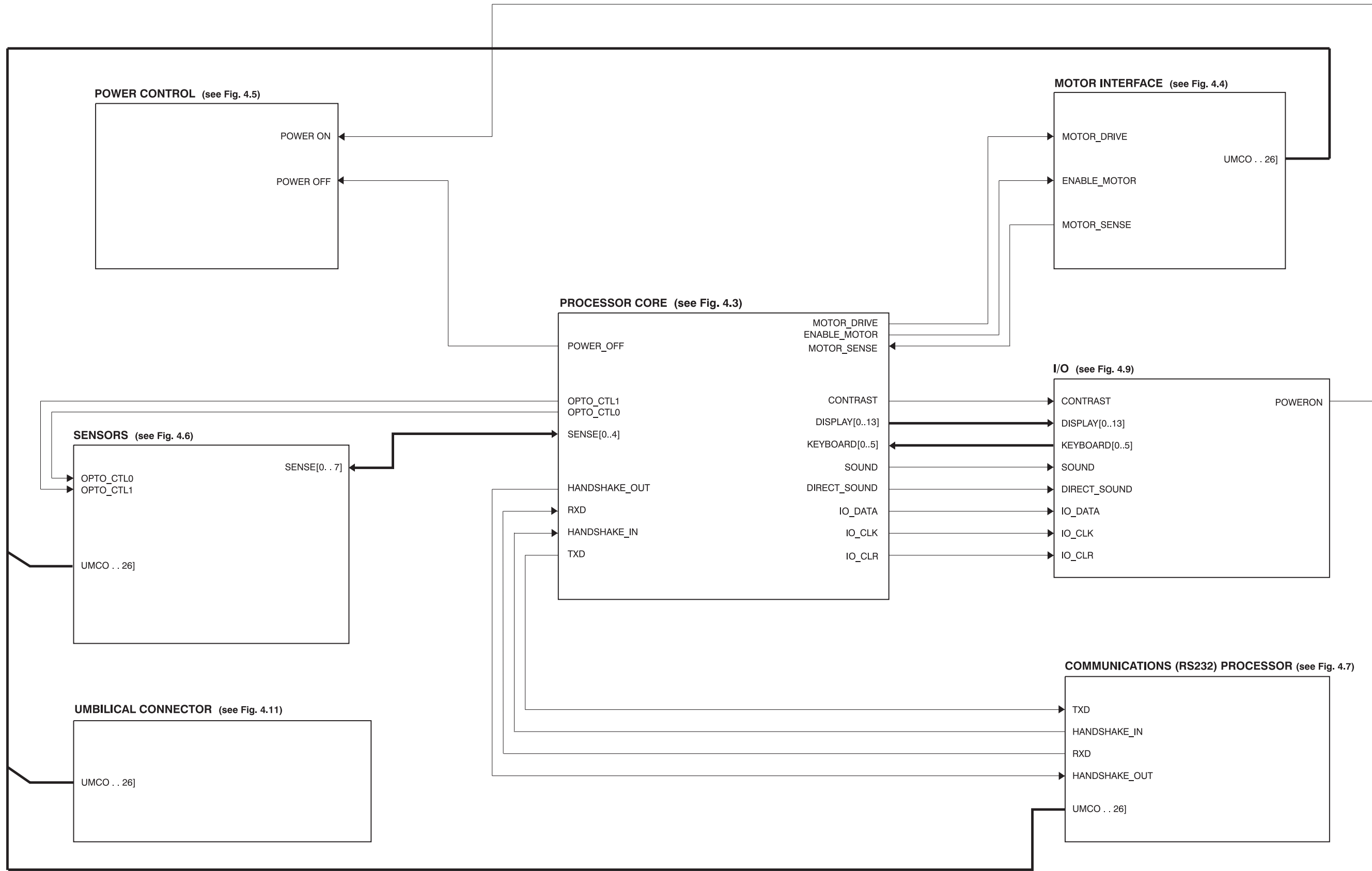

GM1121-A

Figure 4.2 Main board block diagram

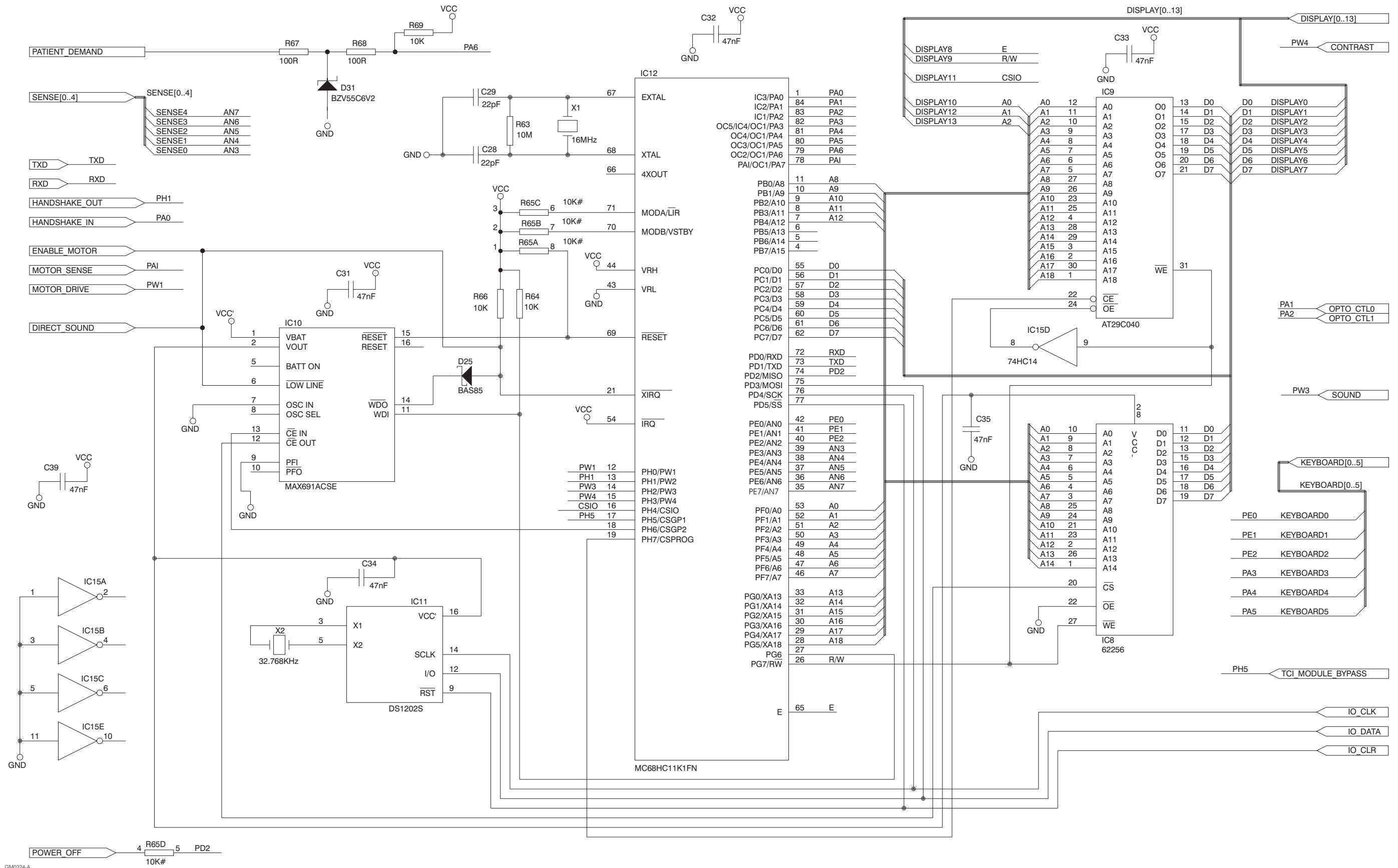

Figure 4.3 Processor core circuit diagram

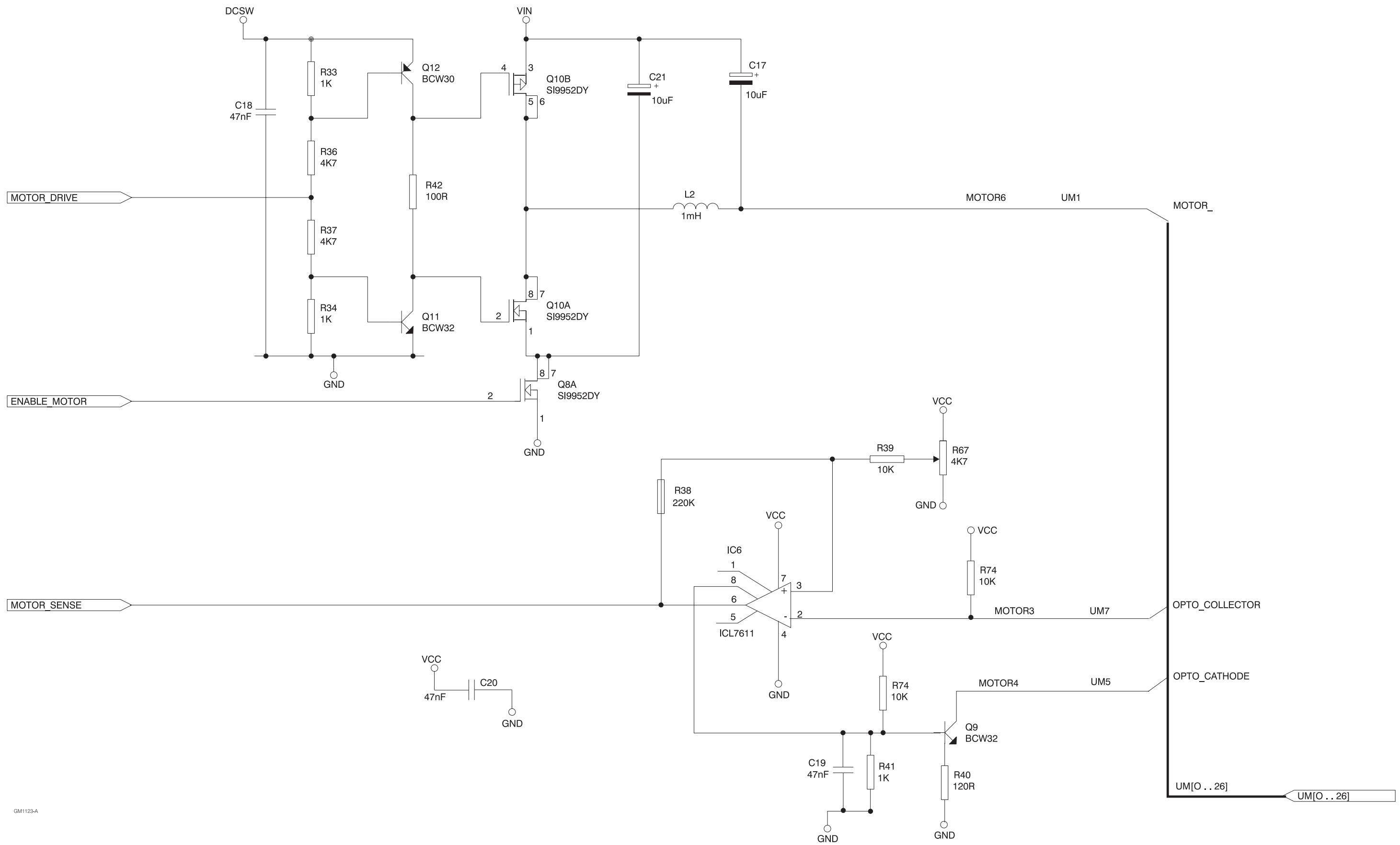

Figure 4.4 Motor interface circuit diagram

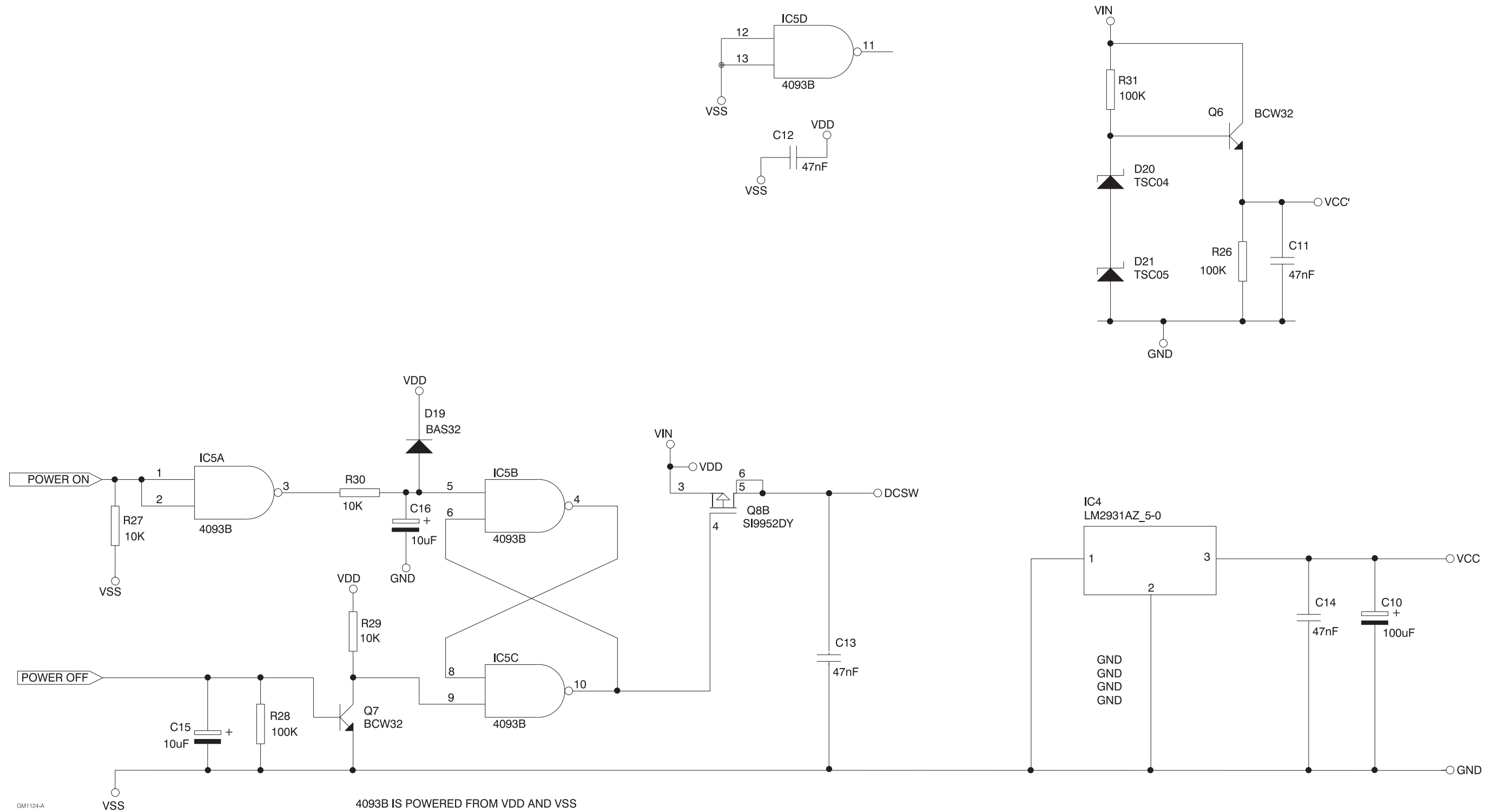

Figure 4.5 Power control circuit diagram

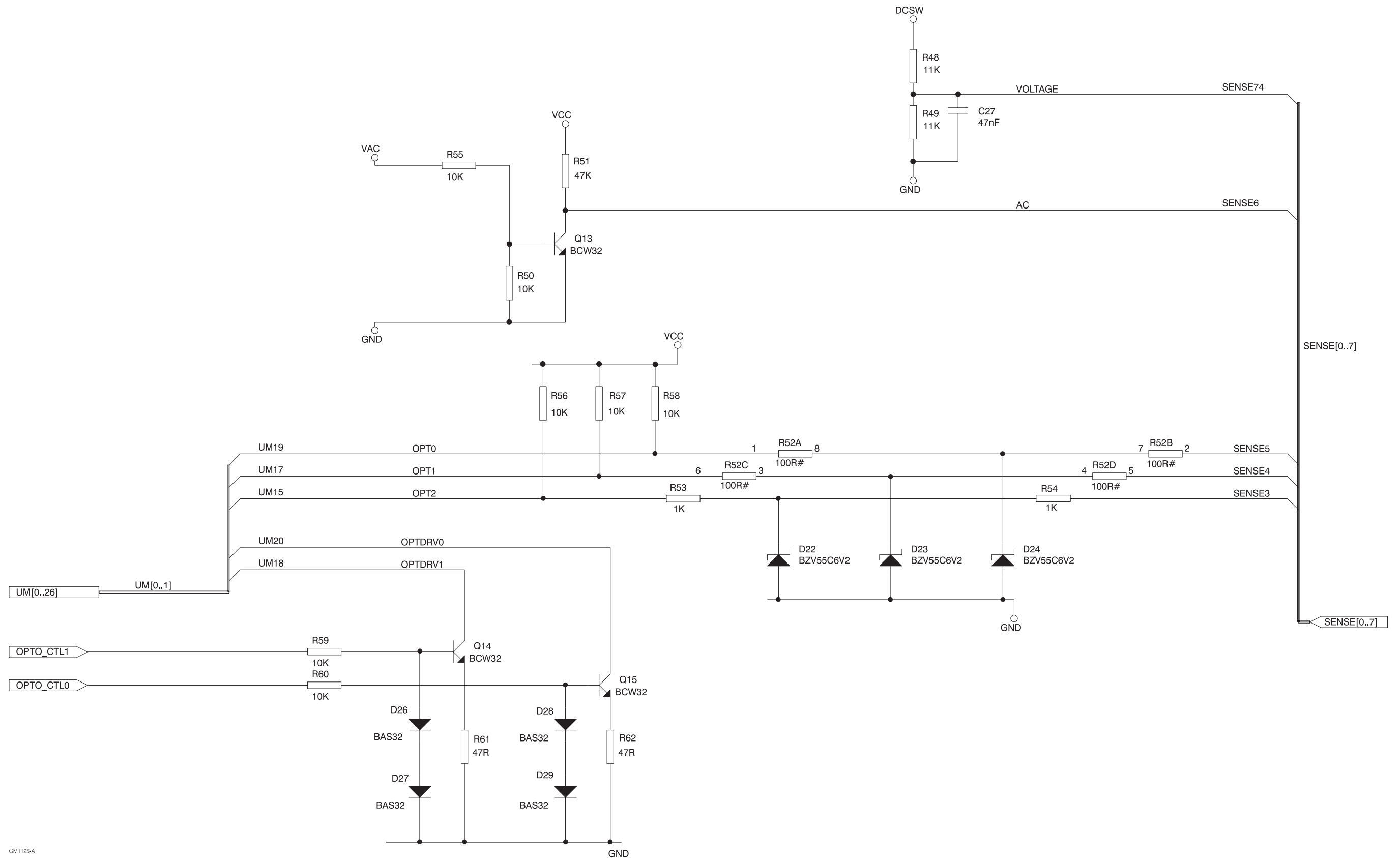
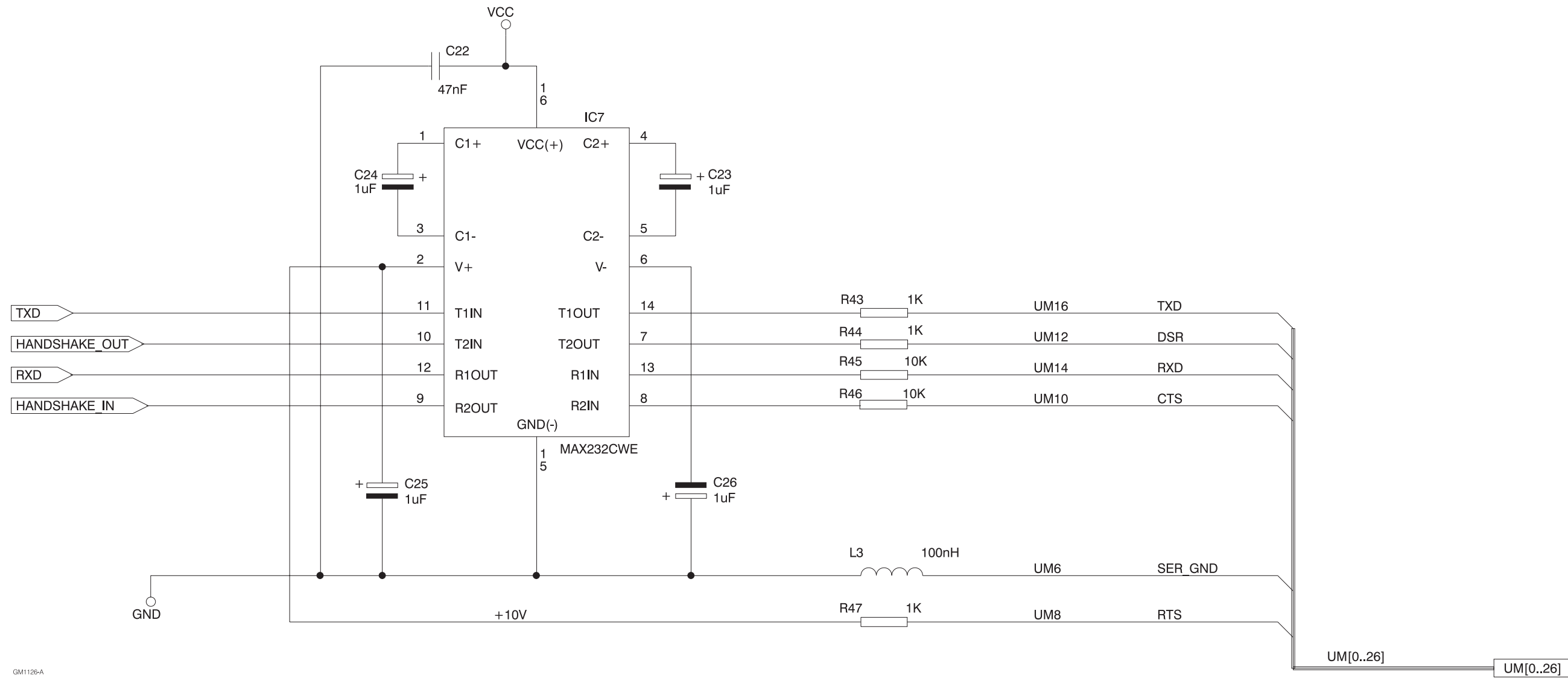

Figure 4.6 Sensors interface circuit diagram



GM1126-A

Figure 4.7 Communications (RS232) circuit diagram

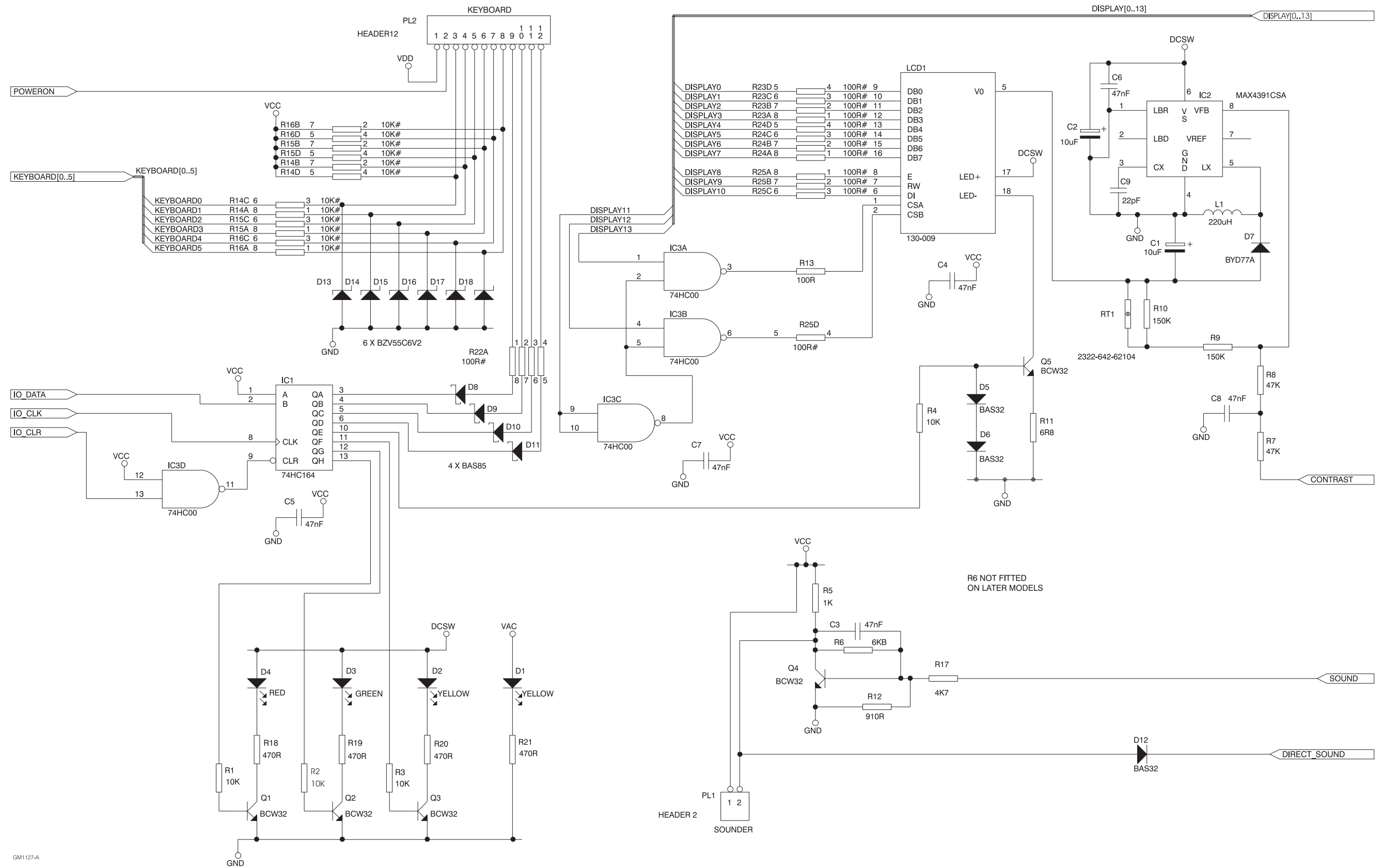

Figure 4.8 Main board input/output interface circuit diagram

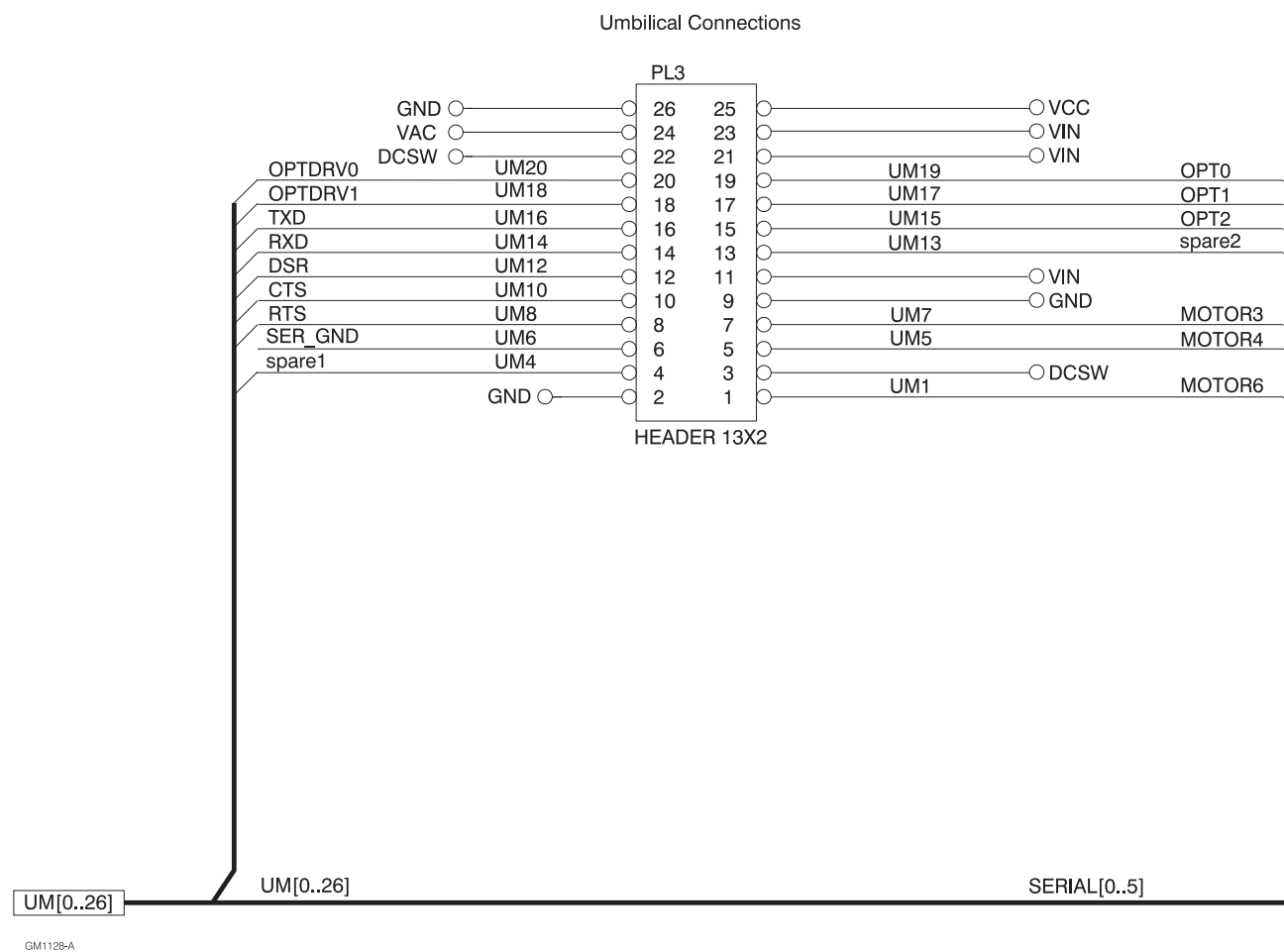

Figure 4.9 Umbilical cable connections diagram

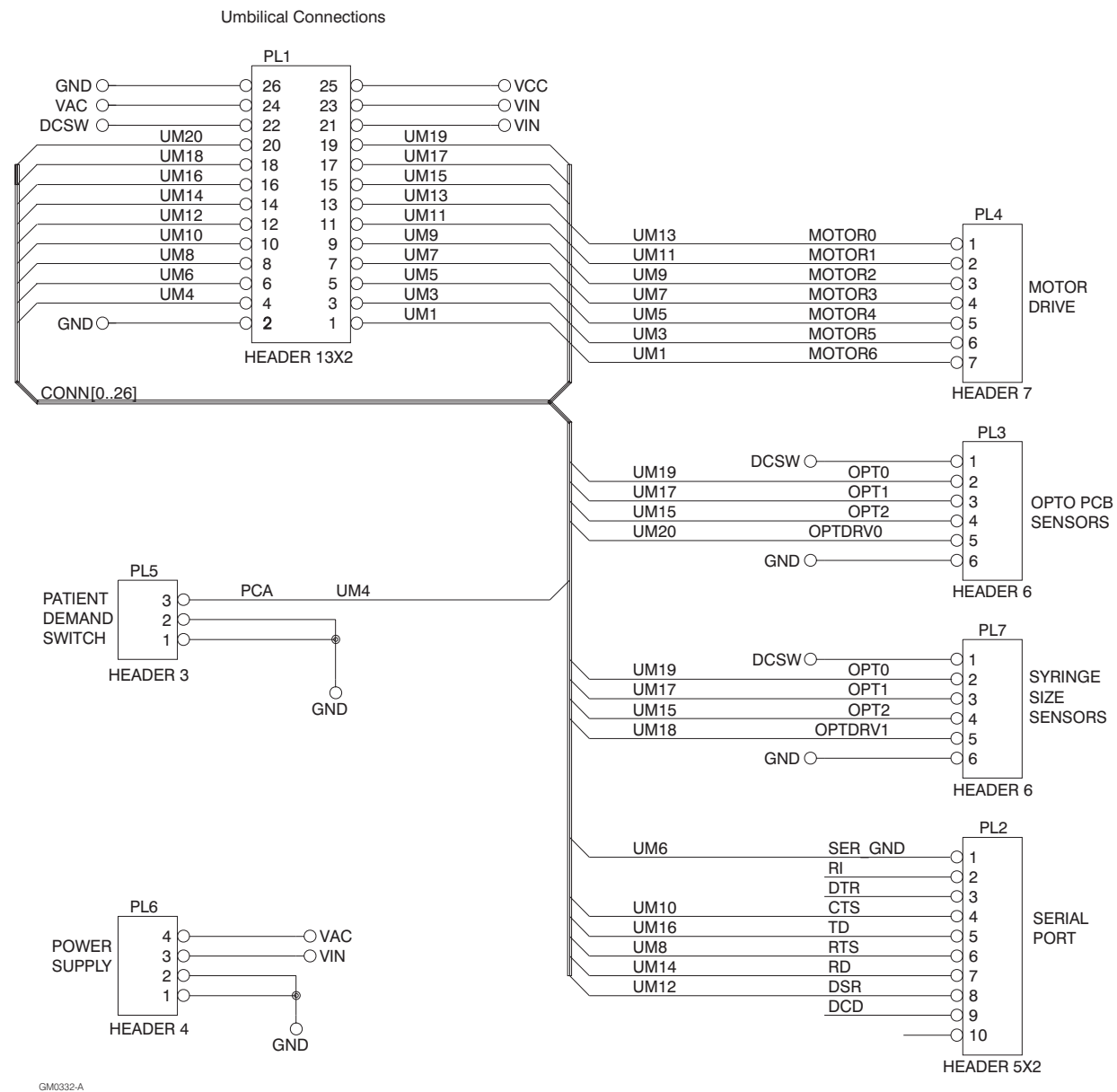

Figure 4.10 Umbilical board connections diagram

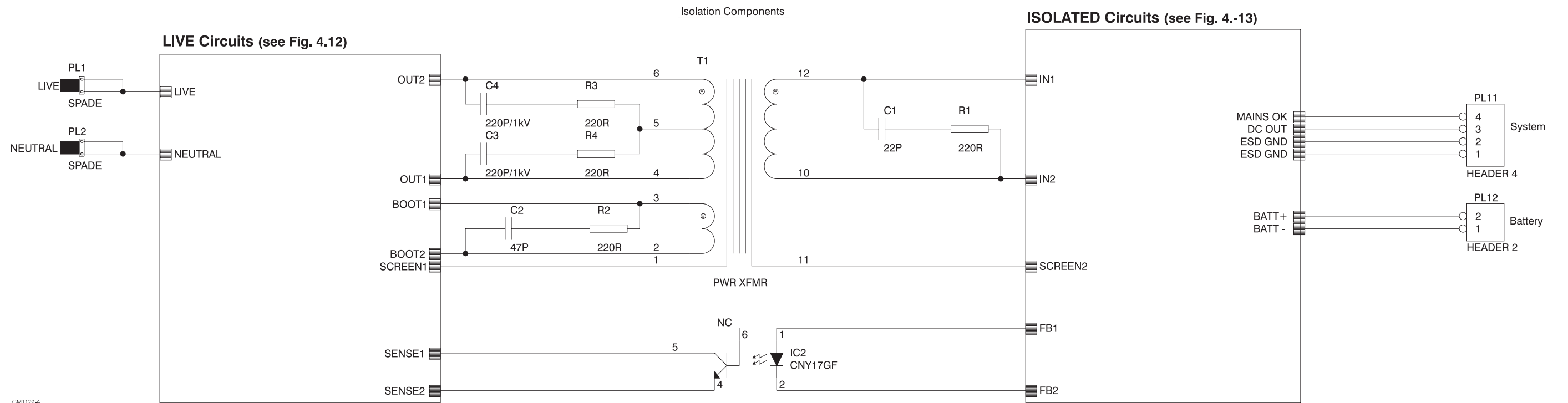

Figure 4.11 Regulator circuit diagram (overview)

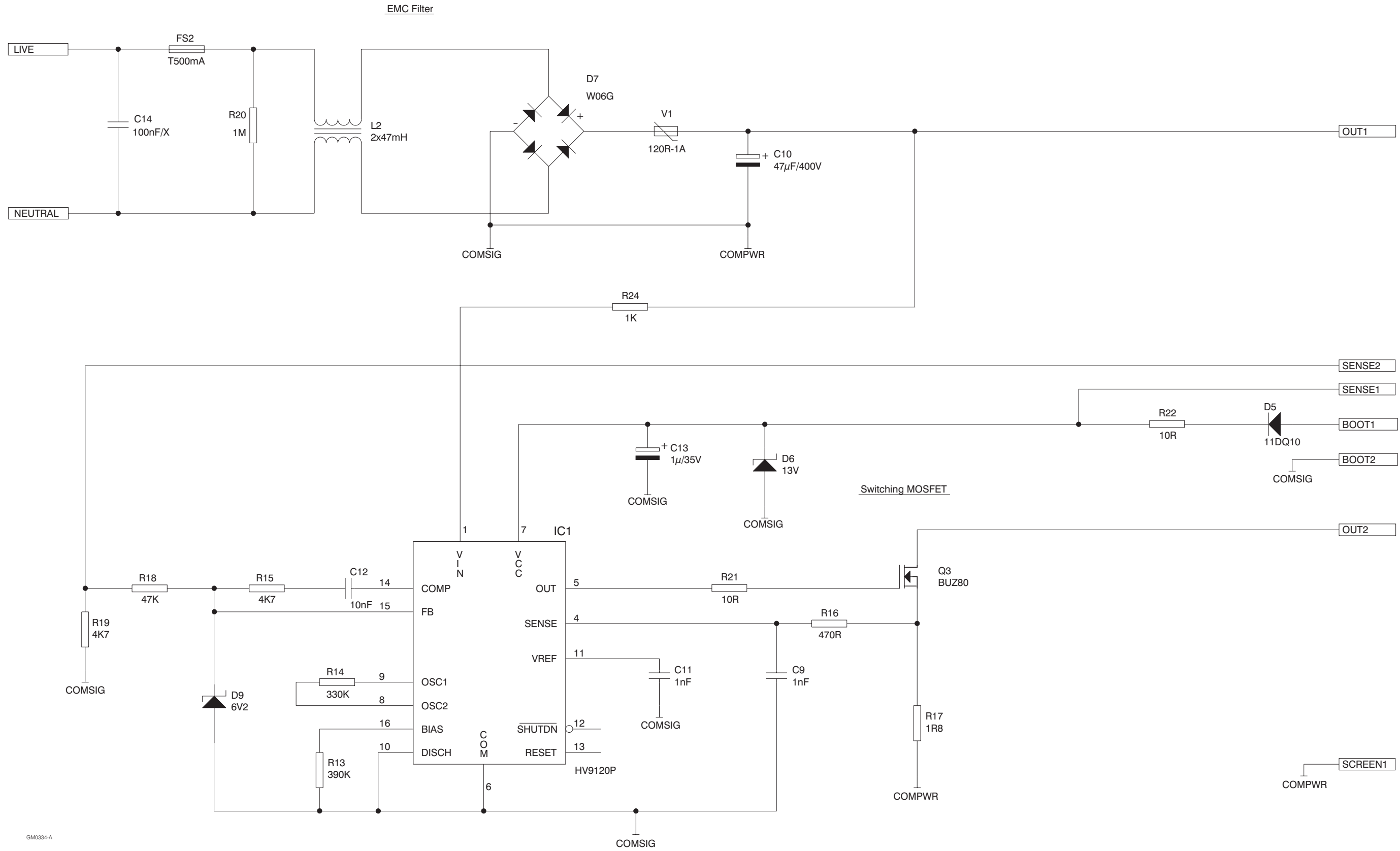

Figure 4.12 Regulator live circuit diagram

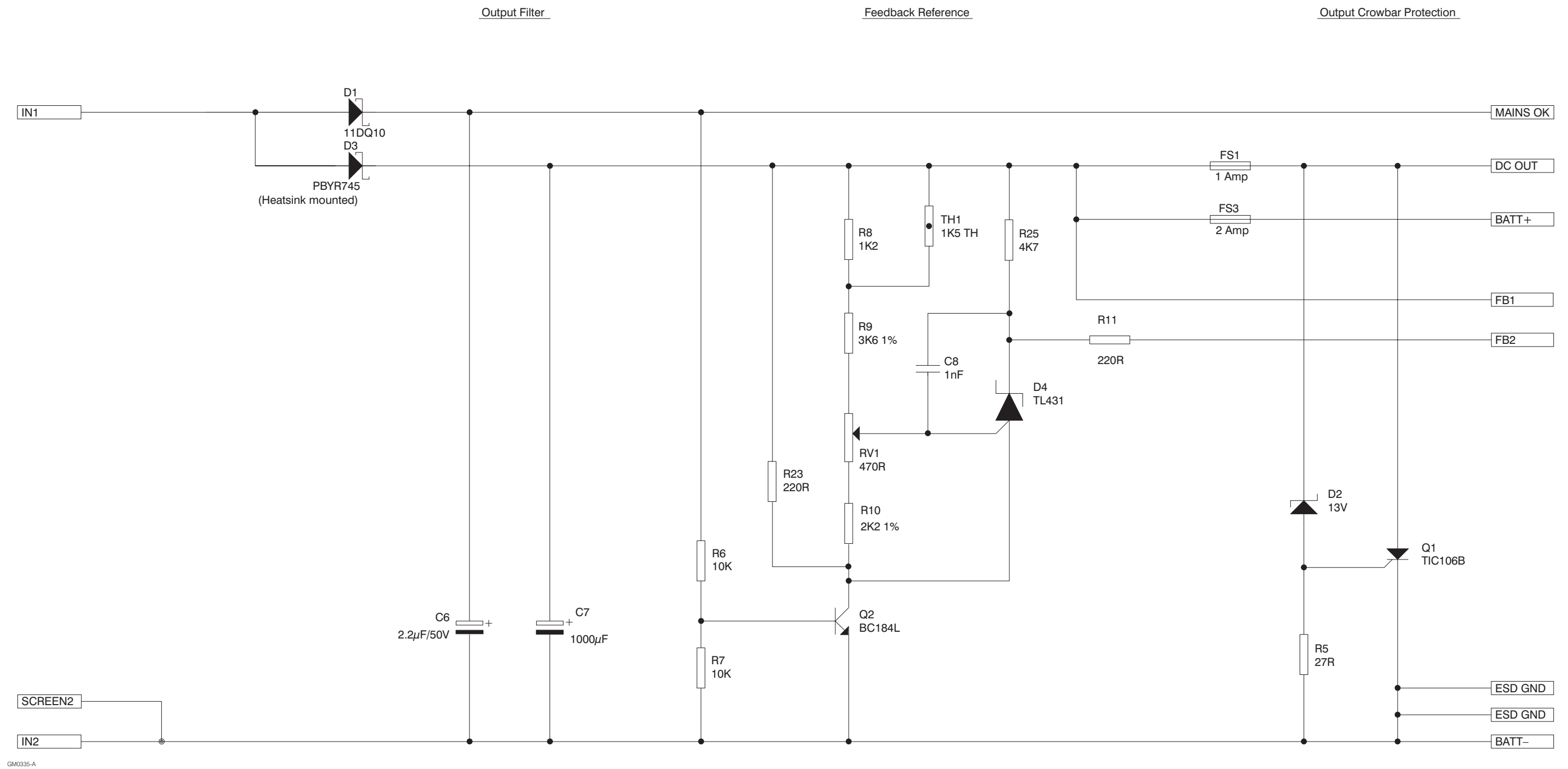

Figure 4.13 Regulator isolated circuit diagram

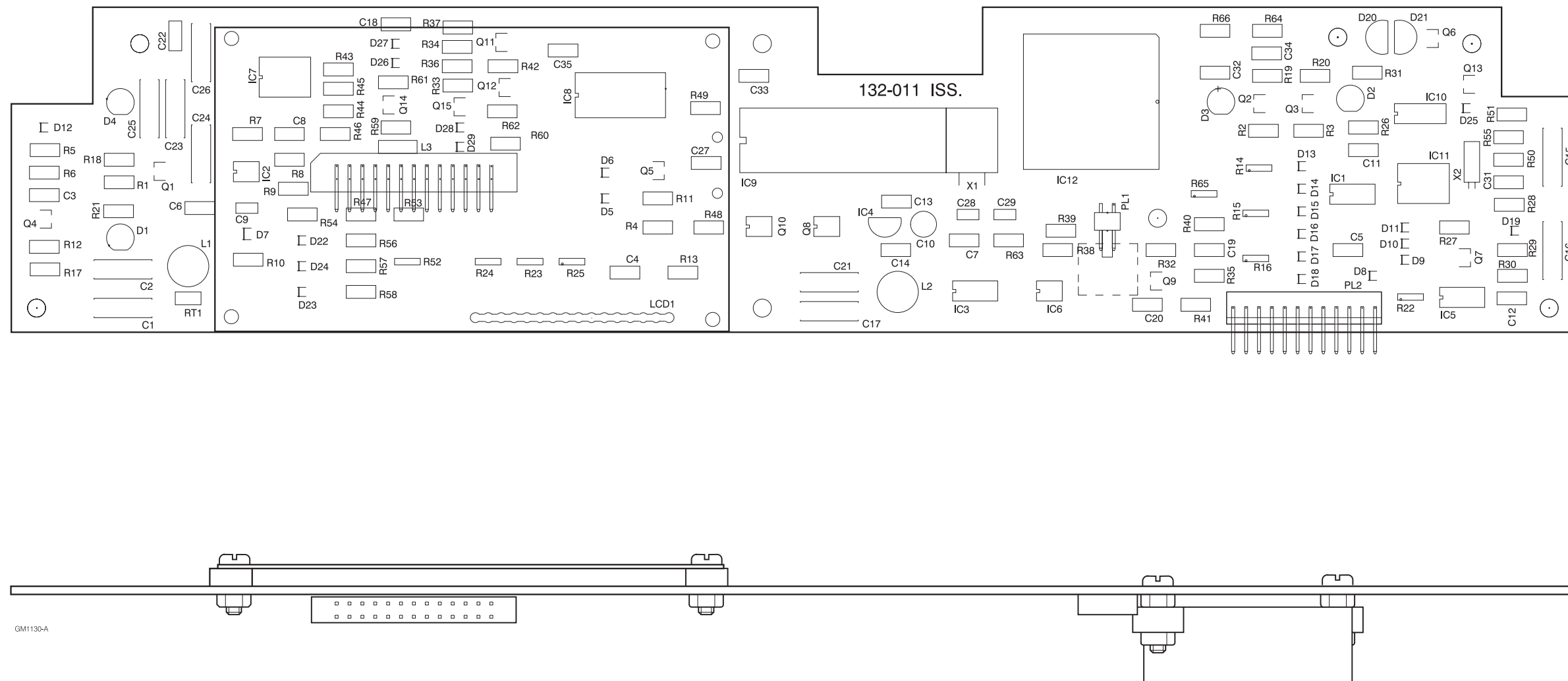
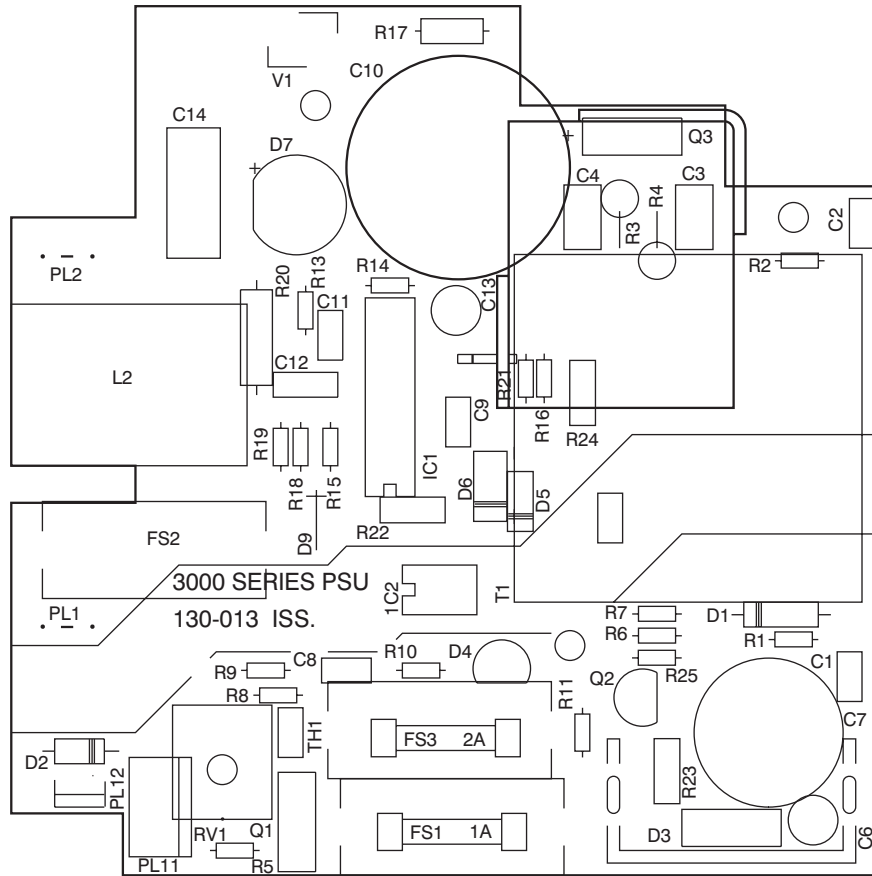
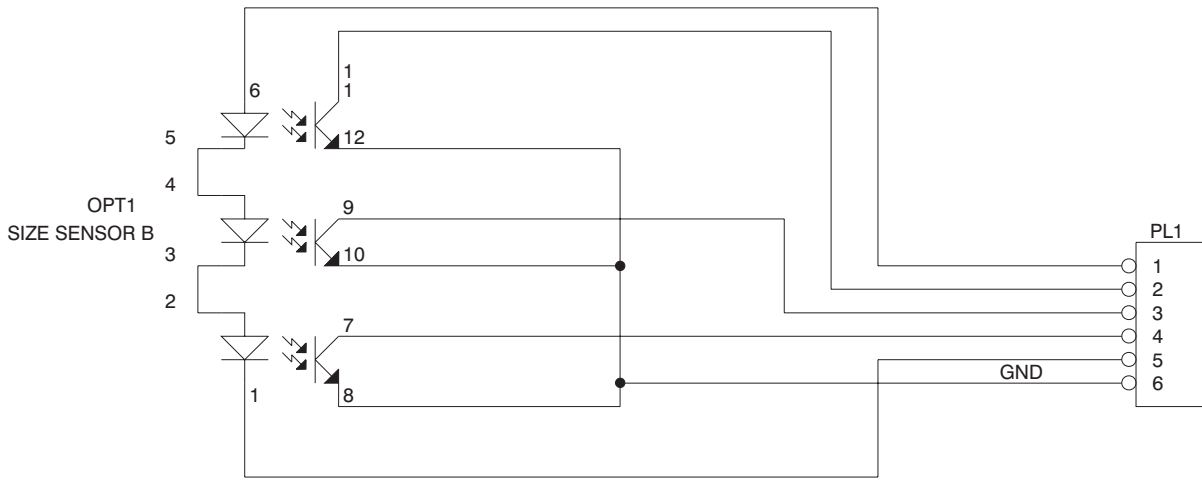

Figure 4.14 Main board: layout of components



GM0337-A

Figure 4.15 Regulator board: layout of components



GM0338-A

Figure 4.16 Syringe size sensors circuit diagram

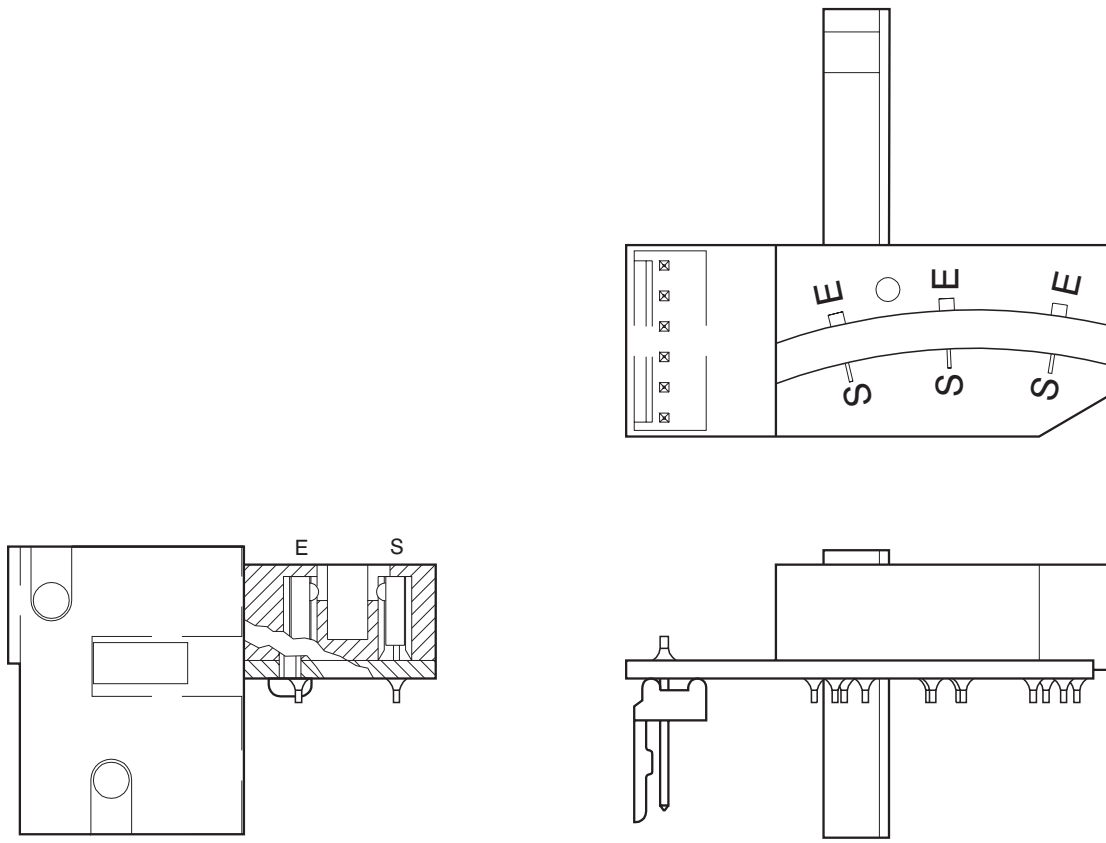

GM0339-A

Figure 4.17 Syringe size sensors board: layout of components

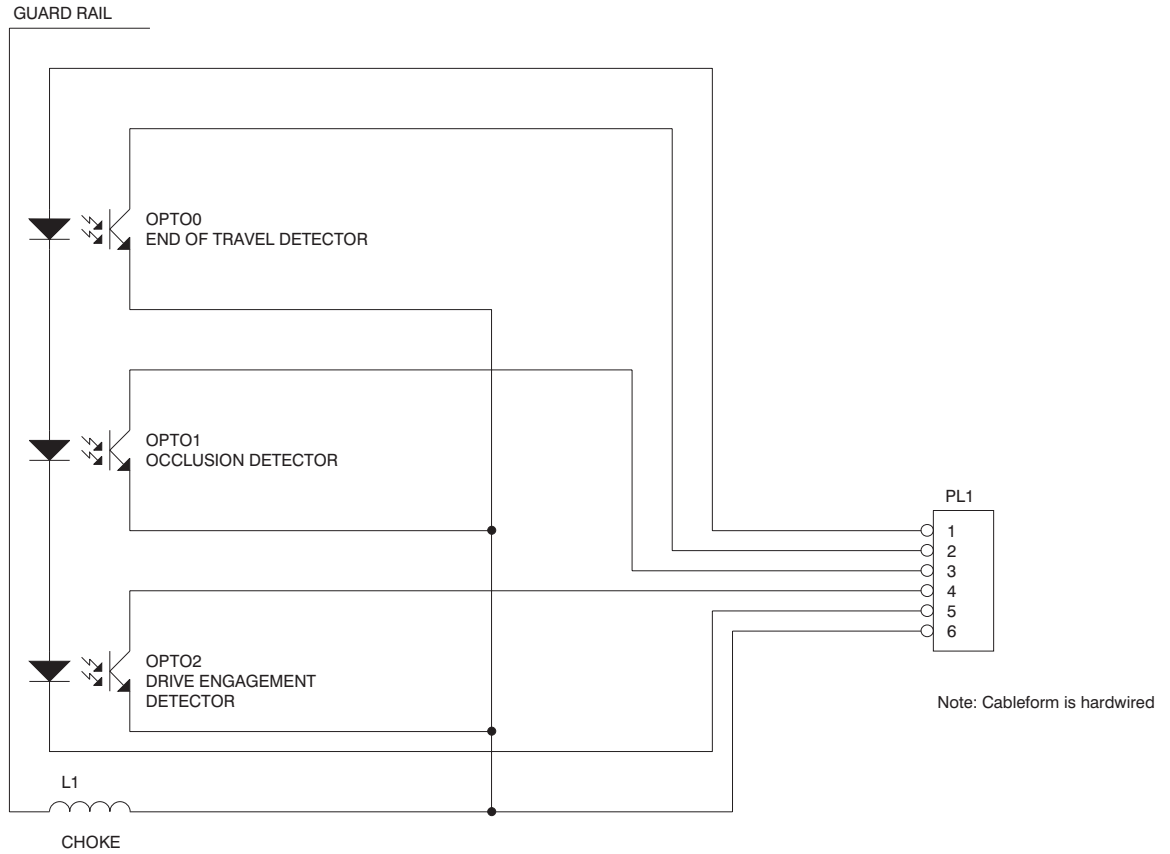

Figure 4.18 Opto sensors circuit diagram

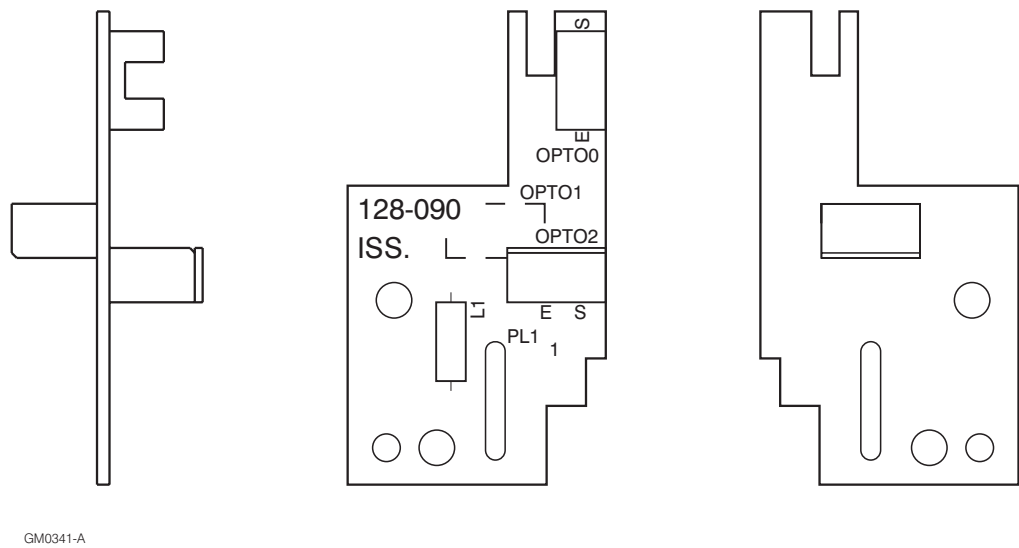
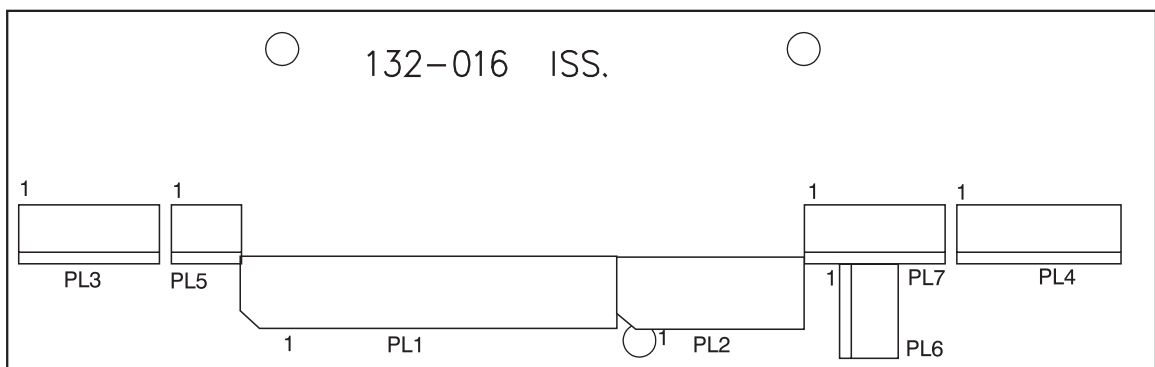

Figure 4.19 Opto sensors board: layout of components



GM0342-A

Figure 4.20 Umbilical board: layout of components

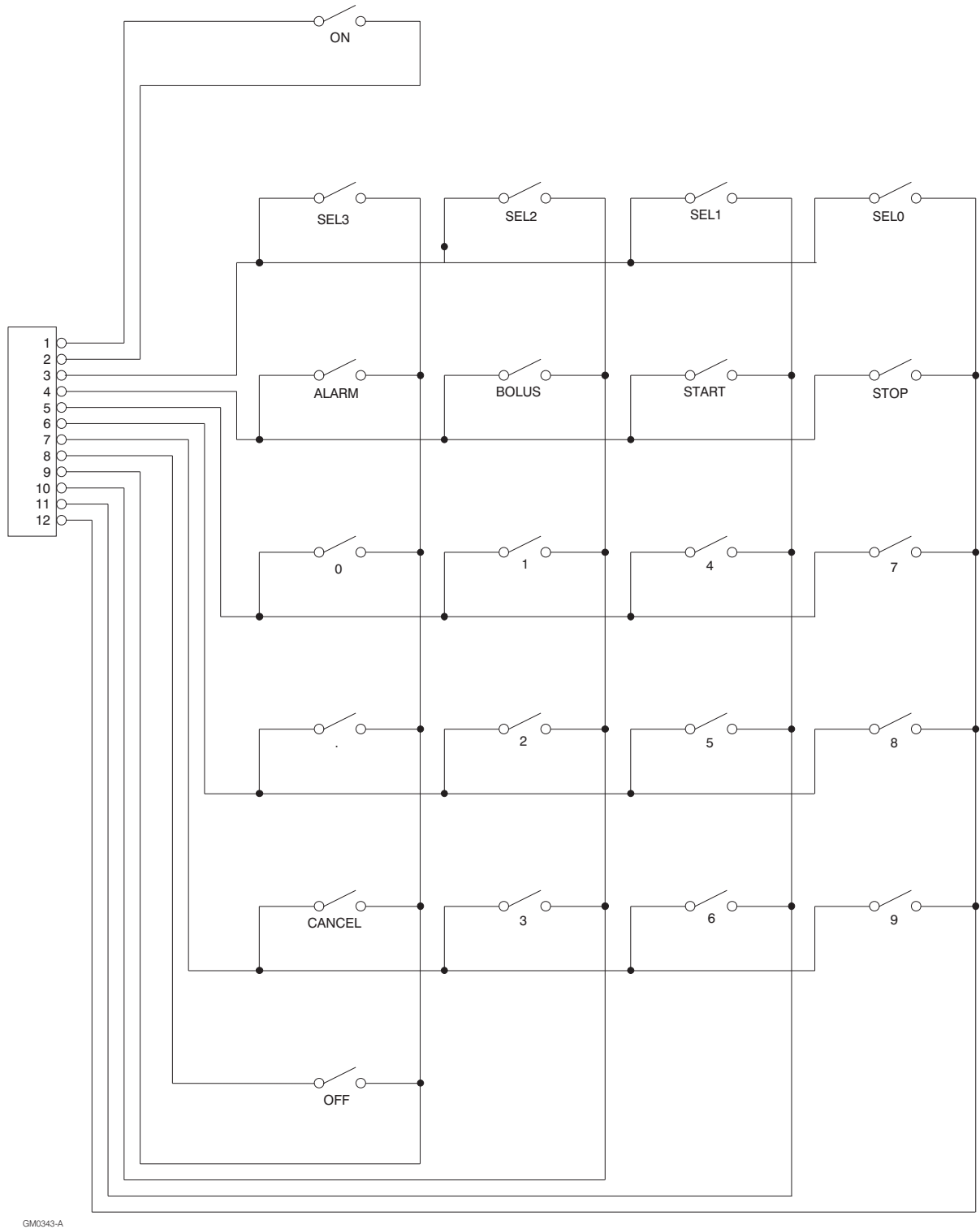
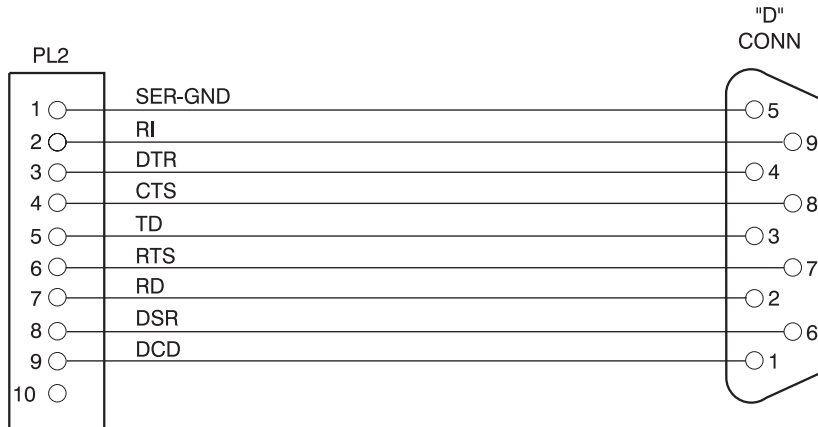

Figure 4.21 Membrane switch panel circuit



NOTE:

The RS232 Serial Interface connections to PL2 are shown on Fig. 4-10

GM1131-A

Figure 4.22 Internal ribbon cable and 'D' connector connections

CHAPTER 5

FAULT CODES, CLEANING AND REPAIR PROCEDURES

3400 ANAESTHESIA SYRINGE PUMP

CHAPTER 5

FAULT CODES, CLEANING AND REPAIRS

Fault codes

Comprehensive fault codes have been designed into the 3400 so that should a fault occur it can easily be identified. The Fault code numbers are used to indicate the type of fault that has occurred.

The micro-processor is capable of recognising faults and generating fault code numbers in the range 0 to 97 (see Table 5.1). The fault codes are not expected to change for future software versions.

The normal operational ALARMS and WARNINGS are fully detailed in the 3400 Instruction Manual.

Table 5.1 Fault codes

Code	Fault	Recommended action
07	RAM test failure	See item 2 on page 5-2
10	Motor fault	See item 4 on page 5-2
11	Watchdog interrupt	See item 2 on page 5-2
22	Unexpected interrupt	See item 2 on page 5-2
30	Unexpected program restart	See item 2 on page 5-2
34	Redundant variable mismatch	See item 2 on page 5-2
35	Variable out of range	See item 2 on page 5-2
38, 39	Motor fault	See item 4 on page 5-2
45	Microprocessor fault	See item 2 on page 5-2
46	Internal watchdog fault	See item 2 on page 5-2
47	Program exception	See item 2 on page 5-2
51	Program exception	See item 2 on page 5-2
52	Program exception	See item 2 on page 5-2
55	Program exception	See item 2 on page 5-2
56	Internal register not correct	See item 2 on page 5-2
57, 58	Calculation error	See item 2 on page 5-2
59	Program exception	See item 2 on page 5-2

(contd.)

Table 5.1 Fault codes (contd.)

Code	Fault	Recommended action
61	Program exception	See item 2 on page 5-2
64	RS232 receiver overrun	See item 1 on page 5-2
66, 67	Comms buffer overflow	See item 1 on page 5-2
68	RS232 buffer overflow	See item 1 on page 5-2
69	RS232 buffer overflow	See item 1 on page 5-2
70	CPU test failed	See item 2 on page 5-2
80, 81	Watchdog test failed	See item 2 on page 5-2
82	Motor faulty	See item 2 on page 5-2
85	Power supply fault	See item 5 on page 5-2
87	CRC test failed	See item 2 on page 5-2
90	EEPROM failure	See item 6 on page 5-2
91	Keyboard fault	See item 3 on page 5-2
93,94,95	Diprifusor fault	See item 6 on page 5-2
96	ROM checksum fault also power on	See item 2 on page 5-2
97	Motor fault	See item 4 on page 5-2

The six items shown below (and cross referenced from Table 5.1) detail the possible cause of a fault, and the recommended action to be taken:

Item	Fault	Possible cause	Recommended action
1	Communication (Comms.) fault.	External interference... e.g. static interference or R.F. interference.	Check communication link and interface cable.
		Circuit fault.	Return to SIMS Graseby.
2	Internal fault.	External interference... e.g. static interference or R.F. interference.	Relocate the pump.
		Circuit fault.	Return to SIMS Graseby.
3	Keyboard fault.	Damaged keyboard.	Replace keyboard.
4	Motor fault.	Faulty motor or lead screw drive assy.	Check motor and lead-screw drive assembly.
5	Power supply.	Faulty power supply.	Check the power supply.
6	—	—	Return to SIMS Graseby.

Cleaning

CAUTION

The 3400 must **not** be immersed in any liquids.
Immediately wipe off any liquid that may be spilt on the pump.

The outer surfaces of the pump can be cleaned by wiping them over with a damp cloth (a dilution of soapy water may be used if necessary).

Repair procedures

WARNINGS

The repair procedures detailed in the sections that follow, must only be carried out by qualified personnel.

Always disconnect the AC supply from the pump before opening the casing.

The safety and reliability of the pump may be compromised by the use of parts other than those specified by SIMS Graseby.

Introduction

In several of the repair procedures that follow, information has been given on how to remove and renew the whole of the particular assembly.

If a single component within an associated assembly is faulty and can be individually repaired, then reference to the appropriate illustrated parts exploded view will enable the single faulty component part to be replaced. If a leadscrew assembly or a half nut is repaired then both of the following checks, and if necessary the associated adjustments must be carried out:

- thrust checks (see page 2-7).
- plunger clamp checks (see page 6-3).

Whenever the case is taken apart the Syringe Size Sensors tests detailed on page 6-1 must be carried out.

Renewal of fuses

The pump contains three safety fuses.

These three fuses are all housed on the Regulator board and may be physically located with reference to Fig. 4.15.

These fuses are as follows:

- FS1 is a fuse located in the isolated DC line, and has a 1 A rating.
- FS2 is an AC supply time-delay fuse and has a rating of 500 mA.
- FS3 is located in the battery supply line and has a 2 A rating.

In order to renew a blown fuse the pump casing must be disassembled as detailed on page 2-5, this action will allow access to all three fuses. A blown fuse must only be replaced by a new fuse of the correct rating.

FS2 can be renewed by pulling off and retaining the fuse protective cover and then prising out the blown fuse. Fit the new fuse and replace the protective cover.

FS1 or FS3 can be renewed by removing and retaining the three pan head fixing screws and insulator in order to displace the Regulator board.

After replacing FS1 or FS3 refit the Regulator board and then reassemble the pump casing as detailed on page 2-5.

Regulator board renewal

The Regulator board is mounted on the rear casing. It is held in place by three pan head self tapping screws.

1. Open the casing as detailed on page 2-5.
2. Disconnect the two spade tags and the two cable connectors, PL11 and PL12.
3. Remove and retain the three screws that hold the board in place, also retain the insulating card.
4. Remove the faulty Regulator board.
5. Fit a new Regulator board by reversing steps 2 and 3 detailed above, and then close the casing as detailed on page 2-5.

Main board renewal

The Main board is mounted on the front casing. It is held in place by six pan head self tapping screws.

1. Open the casing, as detailed on page 2-5.
2. Disconnect PL3, the umbilical ribbon cable, by exerting a firm pressure and sliding the connector towards the batteries.
3. Remove and retain the six fixing screws.
4. Lift up the board and disconnect PL1 and PL2, thus allowing the faulty Main board to be removed.
5. Fit a new board by reversing steps 2 to 5 detailed above, and then close the casing as detailed on page 2-5.

Displacement of Umbilical board tray

The Umbilical tray is situated on the rear casing above the leadscrew assembly. To obtain access to the various components that are situated underneath the tray, the tray will have to be displaced.

1. Open the casing, as detailed on page 2-5.
2. Remove and retain the screw that is situated at the bottom and middle of the tray, this will allow the tray to be lifted up a small distance, being restricted by the ribbon cables.
3. Once the required access has been obtained and the repair carried out the tray can be refitted by replacing the fixing screw, and the casing closed as detailed on page 2-5.

Umbilical board renewal

The Umbilical board is situated on the rear casing and is attached to the tray by three pan head self tapping screws.

1. Open the casing, as detailed on page 2-5.
2. From left to right, remove PL1, PL2, PL6, PL4 and PL7 from the front of the board.
3. Remove and retain the three screws from the front of the Umbilical board, and then lift up the board.
4. Disconnect PL3 and remove the faulty board.
5. Fit a new board by reversing steps 2 to 4 detailed above, and then close the casing as detailed on page 2-5.

Opto sensors board renewal

The Opto sensors board (see Fig. 4.18 and 4.19) is mounted on the rear casing, to the left of the leadscrew (see Fig. 7.1). In order to remove the Opto board, both the Distribution board and PL3 on the Distribution board will have to be removed.

1. Open the casing, as detailed on page 2-5.
2. Remove the umbilical board and disconnect PL3 as detailed above.
3. Displace the umbilical tray as detailed on page 5-4.
4. Remove and retain the screw that is situated just below the Opto board, which holds the plastic cable holder in place.
5. Remove and retain the two screws and washers that hold the Opto board in place.
6. Ease out the plastic flag from the sensor, as the faulty board is lifted out. Be careful not to damage the occlusion disc that is situated underneath the opto board.
7. Fit a new Opto board by reversing steps 2 to 6 detailed above, and then close the casing as detailed on page 2-5(see also page 6-4, plunger clamp test).

Plunger clamp and super nut assy. renewal

This assembly (Fig. 7.2) is held in place by a narrow spring, a circular guide tube and two clamp brackets that retain the square lay shaft. Page 5-8 details the procedures for renewing just the super nut.

1. Open the casing, as detailed on page 2-5.
2. Displace the Umbilical board tray (see page 5-4).
3. Unhook the top of the retaining spring from the syringe size sensor lever arm.
4. Remove and retain the three screws from the two clamp brackets that hold the square lay shaft in place (see Fig. 7.1 and 7.2). Remove and retain the two brackets.
5. Carefully easing out the flag from its housing, lift up the square lay shaft and toggle mechanism.

(contd.)

6. Lift the two guide tubes off their respective seating, then remove the plunger clamp; super nut and lay shaft assembly.
7. Fit the new assembly by reversing the steps 2 to 6 detailed above, and then close the casing as detailed on page 2-5.
8. Carry out the thrust checks and plunger clamp checks/adjustments as detailed on page 2-7 and 6-3 respectively.

Pole clamp renewal

1. Remove and retain the two screws that are inserted through the securing plate into the base of the pump (see Fig. 7.3).
2. Remove the faulty pole clamp assembly.
3. Fit the new assembly by replacing and tightening the two screws through the securing plate into the base of the pump.

Leadscrew assy. renewal

The leadscrew assembly (see Fig. 7.4) is held in the rear casing by two bearing clamp plates, and is also held under moveable tension by a strong spring. The occlusion thrust is set by adjusting the tension of the spring.

A plastic coupling bush on the right hand side of the leadscrew is key-way fitted on its right hand side which enables it to be coupled to the gear box. The other side of the coupling screws into the leadscrew with a left-hand thread, this threading prevents the motor from unscrewing the leadscrew coupling.

Removal

1. Open the pump casing as detailed on page 2-5.
2. Displace the Umbilical board tray (see page 5-4).
3. Displace the Regulator board by removing and retaining the three pan head screws and the top insulating board. This displacement will assist in the following procedures.
4. Remove and retain the two pan head screws that hold the Sensor moulding assembly and the square lay shaft in place.
5. Place the plunger clamp almost to the end of its left hand travel.
6. Remove and retain the two pan head self tapping screws that hold the right hand plastic clamp bracket in place; remove and retain the bracket.
7. Raising up the syringe size sensor lever, and noting the separate case grooves that the leadscrew bearing and the gearbox fit in to, lift out the faulty leadscrew assembly, together with the motor and gear box.
8. The motor and gearbox are coupled to the right hand end of the leadscrew assembly. Uncouple the leadscrew assembly from the gearbox by pulling it away from the gear box shaft.

Renewal

9. Fit a new leadscrew assembly by reversing steps 2 to 8 detailed above. During the fitting of the new leadscrew the spring pressure will have to be released (see below) in order to move the leadscrew assembly to the left, so that it fits correctly into the grooves of the rear casing.

10. Ensure that the groove on the syringe size sensor collar (through which the larger telescopic tube slides) fits correctly into the concaved rear casing.

Releasing the spring pressure

11. If necessary, rotate the leadscrew so that the small grub screw that is situated in the grooved occlusion nut, on the right hand side of the leadscrew, is accessible. Using a 1.5 mm hexagon key loosen the grub screw.

12. Ensuring that the leadscrew does not turn, move the occlusion nut counter-clock wise (i.e. towards the left of the leadscrew) in order to relax the spring tension.

13. When the leadscrew assembly has been correctly positioned tighten the grub screw.

Case assy. and checks

14. Assemble the casing as detailed on page 2-5.

15. Carry out the thrust checks and plunger clamp checks/adjustments as detailed on page 2-7 and 6-3 respectively.

Motor and gearbox assembly renewal

1. Open the casing, as detailed on page 2-5.

2. Remove the motor connector (PL4) from the Umbilical board, and then displace the Distribution tray by removing and retaining the bottom pan head screw.

3. Remove the leadscrew assembly together with the gearbox and motor, as detailed on page 5-6.

4. Remove the faulty motor and gearbox assembly by pulling it away from the leadscrew assembly.

5. Fit the new motor and gearbox assembly by reversing steps 2 to 4 detailed above, and then close the casing as detailed on page 2-5.

Occlusion clutch and disc assy. renewal

The occlusion clutch and disc assembly (see Fig. 7.1) are situated on the left hand side of the leadscrew assembly, underneath the opto sensors board. The leadscrew assembly has to be removed in order to renew the clutch and disc.

1. Open the pump casing as detailed on page 2-5.

2. Remove the Opto sensors board as detailed on page 5-4.

3. Remove the leadscrew assembly as detailed on page 5-6, complete with the motor and gearbox.

4. Remove and retain the two screws and the bracket that holds the clutch and disc assembly in place.

5. Remove the faulty clutch and disc assembly.

6. Fit a new clutch and disc assembly by reversing steps 2 to 4 detailed above, and then assemble the casing as detailed on page 2-5.

7.. Carry out the thrust checks and plunger clamp checks/adjustments as detailed on page 2-7 and 6-3 respectively.

Membrane switch panel renewal

The Membrane switch panel has an adhesive backing that enables it to be fixed to the top of the front casing. Do not bend the new Membrane switch panel or its flexible cable loom.

1. Open the pump casing as detailed on page 2-5.
2. Displace the Main board by removing and retaining the six pan head fixing screws. Disconnect the switch panel ribbon cable connector PL2 from the right hand under side of the Main board (this is a non-locking connector).
3. Starting by lifting a corner, peel the faulty switch panel away from the case. Pull the loose connector out through the front casing slot and remove the faulty switch panel.
4. Remove traces of old adhesive from the front case recess (a cloth lightly dampened with white spirit may be used).
5. From the top of the new switch panel peel back the protective paper backing as far as the top of the display window.
6. Push the connector and flexible lead of the new switch panel through the slot in the case.
7. Align the top edge and sides of the panel with the top and sides of the case recess. Gently rub the top edge of the switch panel to adhere it lightly to the case and then remove the remainder of the protective backing paper.
8. Working from the top downwards and using light pressure lay the panel into the case recess.
9. When the switch panel is positioned correctly into the case recess (i.e. no over-hanging edges), use a soft cloth to rub the panel firmly down, pushing out any air bubbles at the same time.
10. Connect the flexible lead to PL2 (Main board), and using the six screws that were previously removed, refit the Main board to the top half of the casing.
11. Assemble the casing as detailed on page 2-5.

Super nut renewal

Early 3400 pump's were fitted with a half nut, and in May 1999 the half nut was replaced with a three-quarter super nut. The following procedures only make reference to the presently installed super nut, which is a direct replacement for the original half nut.

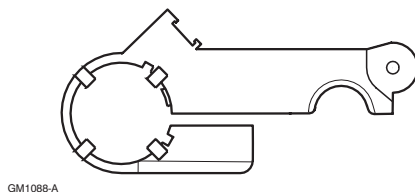

GM1088-A

Half nut

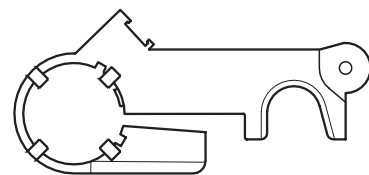

Super nut

The super nut casting (see Fig. 7.2) is clamped onto the left hand end of the outer metal tube by an M4 countersunk screw that is tightened into a recess positioned hexagonal nut. It is also attached to the toggle mechanism by a Spirol connecting pin.

1. Open the pump casing as detailed on page 2-5.
2. Remove and retain the Spirol connecting pin that fixes the super nut to the toggle mechanism.
3. Unhook the top of the retaining spring (2 mm dia. by 2.5 cm long) from the syringe size sensor lever arm.

4. Lift the two guide tubes off their respective seating and then remove the attached assembly complete with the faulty super nut from the pump.
5. Remove and retain the super nut countersunk clamping screw and associated nut.
6. Lever the sides of the super nut apart in order to disengage the casting pip from the locating hole in the guide tube.
7. Fit a new super nut by reversing steps 2 to 6 detailed above, ensuring that the casting pip is placed in the locating hole.
8. Close the casing as detailed on page 2-5.
9. Carry out the thrust checks and plunger clamp checks/adjustments as detailed on page 2-7 and 6-3 respectively.

Syringe size sensor board renewal

The syringe size Sensor board (see Fig. 4.16 and 4.17) and its moulding are fixed adjacent to the motor, at the right hand end of the leadscrew assembly (see Fig. 7.1).

The moulding is fixed in place by two pan head self tapping screws. The board is fixed to the moulding by a single self tapping screw.

1. Open the casing as detailed on page 2-5.
2. Remove the connector PL1 from the Sensor board.
3. Remove and retain the two moulding pan head fixing screws.
4. Lift out the Sensor moulding and its shim, and also the attached board.
5. Remove and retain the fixing screw situated between the board and the moulding.
6. Carefully prise the board away from its moulding. A small amount of resistance may be experienced when prising the three extending opto sensors (that are fixed to the board) away from the moulding.
7. Fit a new sensor board by reversing steps 2 to 6 detailed above, and then close the casing as detailed on page 2-5.
8. Carry out the syringe size sensors tests as detailed on page 6-1.

Plunger clamp repair

The plunger clamp cover must be removed in order to reach the internally located lock or pin moulding (see Fig. 7.2). The outer casing of the clamp is fixed to the right hand end of the outer tube.

1. Remove and retain the two screws that hold the plunger clamp cover onto the outer casing, and remove the cover.
2. The lock and pin moulding together with the associated spring will become accessible.
3. As required, fit a new lock and/or pin, then assemble the clamp as detailed in 1 above.

Batteries. Checks and replacement

WARNING

The internal pump batteries must be disposed of in accordance with the manufacturers instructions. Lead acid batteries must **not** be placed in the normal waste stream.

SIMS Graseby recommend that the condition of the three internal batteries is checked at least annually.

The batteries will normally last several years, but if they should fail to charge then all three batteries must be replaced at the same time. The batteries are held in place in the front casing by three-pronged flexible plastic mouldings.

Connect the pump to AC power; ensure that the pump is switched off and the yellow AC light is illuminated, this will allow maximum DC charge supply from the regulator board. Fully charge the batteries for at least 14 hours. Remove the AC power and run the pump at 99.9 ml/hr. If the **LOW BATTERY** alarm appears on the pump's display before 10 hours has elapsed then all three batteries should be replaced, as detailed below:

1. Open the case as detailed on page 2-5.
2. Noting their orientation, prise out the three faulty batteries. Also noting the connections remove all six spade tags.
3. Connect three new fully charged 2 V, 2.5 AH, lead acid, D Cell batteries by reversing the steps detailed in 2 above, ensuring that the two rubber packing spacers that are attached to the pillars are still in place.
4. Close the casing as detailed on page 2-5.

Front and/or rear case repair

In March 1999 SIMS Graseby introduced a new type strengthened and modified front and rear case moulding for their 3000 range of syringe pumps. See figures 1 and 2.

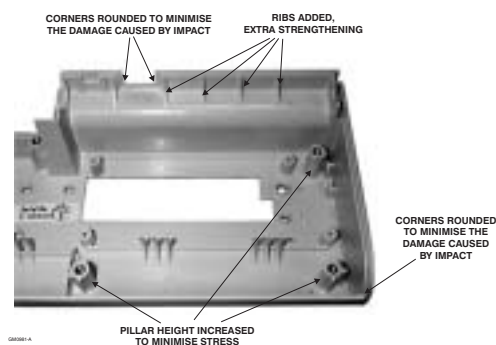

Fig.1 Strengthened front case moulding



Fig. 2 Strengthened rear case moulding

If an old style front or rear case becomes damaged and requires replacing then the appropriate repair kit is available from SIMS Graseby. There are two kits (front or rear case) which each contain all the necessary instructions and parts to carry out a repair.

The contents of the repair kits are shown in Tables 5.2, 5.3 and 5.4 overpage. The items marked with an asterisk (*) may be obtained individually.

Table 5.2 Front case spares kit

Description	Part No.	Remarks
Front case spares kit*	0132-0101	
Case front	0132-0099	
Syringe clamp assembly*	0131-0149	
Button, moulded*	0131-0216	2 off
Instruction leaflet	0131-0156	
Size sensor flag spares kit*	0137-0025	See table 5.3
Foam spacer type 3*	0131-0218	2 off
Case templates*	0131-0235	2 off
Radius gauge*	0131-0234	Stainless steel
Case screws (6 off)	5001-0345	M4x12 pozi pan

Note:

The Front panel label (membrane)* will be Country dependent and can be supplied,
e.g. 0132-0007 English

Table 5.3 Size Sensor Flag spares kit

Description	Part No.	Remarks
Size sensor flag spares kit*	0137-0025	
Size sensor flag	0132-0090	
Size sensor shim (0.6 mm thick)*	0130-0107	
Size sensor shim (1.0 mm thick)*	0130-0108	
Size sensor shim (1.2 mm thick)*	0130-0190	
Size sensor shim (1.4 mm thick)*	0130-0185	
Opto moulding	0130-0024	4.65 mm thick
Screws, No. 4 x 5/8 ins. Self tap	5017-3410	2 off
Grub screw, M4 x 6, nylon*	0130-0144	
Tamper proof protective cap*	0131-0136	
Instruction leaflet	0131-0217	

Table 5.4 Rear case spares kit

Description	Part No.	Remarks
Rear case spares kit*	0132-0104	
Case rear	0132-0100	
Foam spacer type 1*	0131-0204	
Foam spacer type 2*	0131-0205	3 off
Rubber feet*	0126-0028	2 off
Instruction leaflet	0131-0156	
Case screws (6 off)	5001-0345	M4x12 pozi pan

* These items may be obtained individually.

Note:

The Case rear label will be Country dependent, and can be supplied,
e.g. 0132-0091 240 V English

CHAPTER 6
FUNCTIONAL TESTS

3400
ANAESTHESIA SYRINGE PUMP

CHAPTER 6

FUNCTIONAL TESTS

Introduction

Carry out the following tests (Table 6.1) before putting the pump into service for the first time, and thereafter as required. The following functional tests have been designed to verify that the pump is safe to use. It has been assumed that the Technician who will be carrying out the functional tests, is familiar with the operation of the pump as detailed in the 3400 Instruction Manual.

If any one of the pumps functional tests fail and you are unable to rectify the fault yourself, then contact either your local representative or SIMS Graseby (Customer Care).

Table 6.1 Functional tests

Step	Test	Method	Correct result
1	Mechanical inspection	Before applying AC power to the pump, check that the case and exposed mechanical parts are free from any damage.	No visible damage.
2	Electrical safety test.	Using a test voltage of 500 V DC, measure the insulation resistance between the AC inlet and the exposed metal parts.	The insulation resistance must be greater than 200 Meg ohm.
3	Initial power ON .	Connect the AC supply. Press the ON button.	The AC LED lights. All four LEDs are briefly illuminated; the sounder activates, and the STOP and AC LEDs remain on if in the setup mode. If a syringe is fitted, the syringe type; size and the last infusion rate will then be displayed.
4	Syringe size sensors.	Perform with plunger clamp 40 mm from RHS and also at extreme LHS. Insert (in turn) the following diameter rods in the syringe cradle: 11.2 mm diameter rod. 12.5 and 15.0 mm rod. 16.2 and 18.2 mm rod. 21.0 and 23.0 mm rod. 23.7 and 26.8 mm rod. 29.0 to 33.1 mm rod.	SYRINGE INVALID displayed. Syringe size 5 displayed Syringe size 10 displayed Syringe size 20 displayed Syringe size 30 displayed Syringe size 60 displayed

Note:

SIMS Graseby manufacture a set of 18 Syringe Size Sensor gauges (Part No. 0131-0202, see Appendix page A-5). The SIMS Graseby Customer Care Department is able to take orders for these gauges and will supply the current price. This set of gauges enables test No. 4 to be carried out on all the 3000 Series of pumps.

(contd.)

Step	Test	Method	Correct result
5	Membrane buttons and display.		
	ON/OFF buttons.	With the pump ON , press the OFF button.	The display goes blank, but the AC LED remains lit.
		Press the ON button.	As in Step 3 (initial power ON)
	Numeric buttons.	Press the four following sets of numeric buttons, and press the CANCEL button after each sequence:	Check that the rate display shows the following:
		1. Full stop (.) then 9.	0.9 ml/h then 0.0 ml/h.
		2. 1; 2 and 3.	123 ml/h then 0.0 ml/h.
		3. 4; 5 and 6.	456 ml/h then 0.0 ml/h.
		4. 7; 8 and 9.	789 ml/h then 0.0 ml/h.
	Totalizer.	Check that the totalizer buttons operate correctly (see Instruction Manual).	Display shows volume infused since last reset, then resets to zero when the reset button is pressed.
	Infusion.	Fit a syringe and move the plunger clamp to the closed (forward) position. Press the START button.	The syringe type and size is briefly displayed; the infusion starts with the START LED flashing, and the running indication arrows on the display also flashing.
	Bolus.	Check that the bolus facility operates correctly (see Instruction Manual).	Alarm and start lamps flash and the display shows the bolus delivered.
	Infusion rate.	Check that the infusion rate can be changed (see Instruction Manual).	The displayed rate of infusion changes.
		Press STOP .	The pump changes to its set-up mode.

(contd.)

Step	Test	Method	Correct result
6	AC power failure.	With a syringe inserted press the START button to start an infusion, then switch off the AC supply externally. Switch on the AC supply.	The alarm sounds intermittently; MAINS FAIL is displayed (also intermittently) and the pump continues running under battery power. The AC lamp lights.
7	Linear accuracy. Use the linear accuracy gauge (see page 6-5).	Set the following: <ul style="list-style-type: none"> • syringe type to BD, • the rate to 400 ml, • plunger clamp to 60 ml. Purge the system to remove any backlash then run the pump for exactly 90 seconds.	Check that the plunger clamp moves a distance of 18.1 ±0.3 mm. See also page 6-5.
8	Occlusion.	The occlusion thrust is factory set by applying an opposing force to the plunger clamp. This is achieved by using weights.	Refer to page 2-6.
9	Plunger clamp alignment.	Close the clamp at mid-position. Run an infusion of at least 99.9 ml/h. After 5 seconds check clamp position.	Front edge of clamp must be between 8 and 10 mm above surface of top cover. See page 6-5, Taper Gauge.
	Note:		
			If this test fails then the super nut will have to be loosened, this will allow the plunger clamp to be manipulated up or down a small distance, thus enabling the required 8.0 to 10 mm gap to be achieved.
10	Plunger clamp open, leadscrew disengaged.	Load syringe and set an infusion. Open the plunger clamp. Press START . Press the ALARM button.	The alarm sounds, the red ALARM LED flashes and CLAMP OPEN is displayed. The alarm is silenced.
11(i)	Syringe warnings ... EMPTY/OCCLUSION	Using a BD 60 ml syringe, set the rate to 200 ml/h. Set the syringe to approx. 5 ml before the end of travel. Press the bolus button twice and hold it until the clamp reaches the end of its travel.	At the end of travel a continuous alarm sounds and the message ... EMPTY/OCCLUSION occurs and the pump stops.
11(ii)	ENDED (KVO=.5)	Set a rate of 100 ml/h and the syringe to 14 ml. START the pump.	At 2 ±2 ml (syringe) an alarm sounds and the message ... ENDED (KVO=.5) appears.
	Note:		
			When carrying out test No. 11(ii) on a Perfusor pump ensure that the syringe is set to a minimum of 18 ml.

Plunger clamp alarm checks

The dual ramp gauge (Part number 0131-0084) is used to check that the ...

PLUNGER CLAMP OPEN

alarm is operating correctly when the plunger clamp is set to two alternative infusing positions, as shown below:

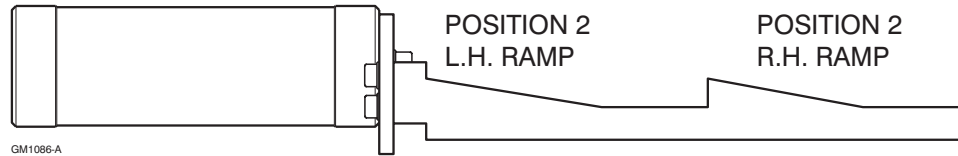

Outline of dual ramp gauge

Ramp check procedures

1. Fit the dual ramp gauge onto the pump.
2. Close the plunger clamp at a position that is just clear of the bottom end of the right hand ramp.
3. Set the pump to infuse at a rate of 200 ml/h and then press the **START** button.
4. Check that during the first 30 seconds of travel (as the leadscrew is fully engaged), that the plunger clamp remains clear of the ramp.
5. Check that as the plunger clamp runs up the right hand ramp a ...

CLAMP OPENED

- alarm occurs within 10 minutes of pressing the **START** button.
6. Repeat the above check with the plunger clamp placed just clear of the left hand ramp.

If the pump fails the ramp gauge checks (on the earlier manufactured pumps) then it is recommended that the half nut is changed for a super nut (see page 5-8) and that the three following modified items should also be fitted to the pump:

1. A new style square shaped flag (Part No. 0127-0019, as shown below) in place of the old style flag.
2. A new style shaft bracket (Part No. 0127-0052, as shown below). This bracket is identified by a 'V' notch that appears on one of the prongs.
3. Two new thicker washers (Part No. 5014-3020) in place of the previously fitted thinner washers on the status sensors board.

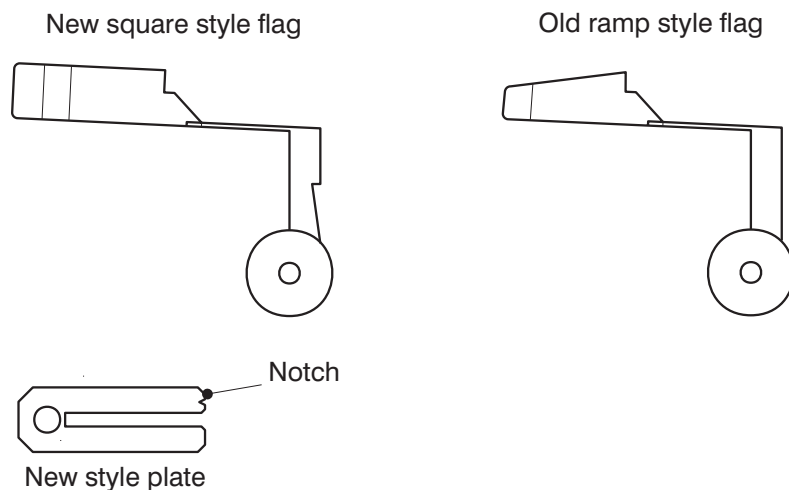

Linear accuracy The linear accuracy gauge (part number 0131-0230) when placed on the pump, is able to check that the pump's plunger clamp moves a given distance in a specified time. Initially, the pump will have been preset to given parameters, then set to run for a specified time and the distance that the plunger moves being observed on the measurement dial of the gauge.

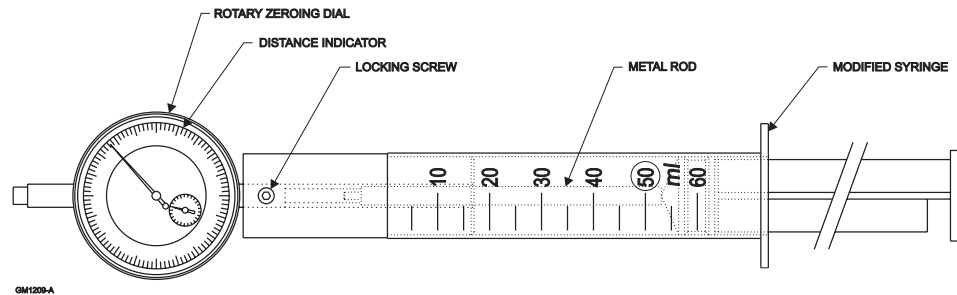

Linear accuracy gauge

Test procedures *Test No. 7, see page 6-3*

1. Place the gauge onto the pump with the syringe plunger almost fully extended.
2. Move the pump's plunger clamp to the left until the gauge plunger is a short distance away from the metal rod that activates the dial indicator.
3. Turn the pump on and check that the pump shows that the syringe brand and size is BD 60 ml.
4. Press the **PURGE** button until the syringe plunger just activates the gauge indicator. This action will ensure that any pump backlash is removed.
5. Rotate the outer rim of the gauge to set both dial indicators to zero.
6. Set the pump to deliver an infusion rate at 400 ml/hr.
7. Check that the dial records that the plunger clamp has moved a distance of 18.1 ± 0.3 mm in 90 seconds. See also page 6-3.

Plunger clamp alignment

The taper gauge (part number 0131-0227) enables the gap between the pump's plunger clamp and the case to be measured accurately. This measurement is important as it ensures that the plunger clamp will engage onto the flanges of the smaller sized syringes correctly.

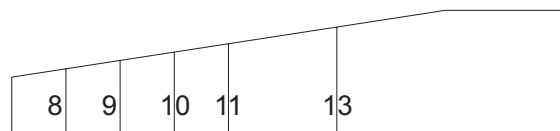

GM1210-A

Taper gauge

Test procedures *Test No. 9, see page 6-3*

1. Switch the pump on and set the rate to at least 99.9 ml/hour.
2. Close the plunger clamp at approximately its mid position.
3. Run the pump for 5 seconds.
4. Using the taper gauge check that the front edge of the plunger clamp is between 8.0 mm and 10.0 mm above the surface of the case.

CHAPTER 7
ILLUSTRATED PARTS LIST

3400
ANAESTHESIA SYRINGE PUMP

CHAPTER 7

ILLUSTRATED PARTS LISTS

Figure 7.1 General assembly

Item	Description	Part number	Remarks
	Model 3400		
	English	0132-0001	
	110 V model	0132-0701	
	German	0132-0707	
	Zeneca	0132-0710	
	German Perfusor	0132-0714	
	English with Euro mains plug	0132-0728	
	Australian	0132-0740	
	Hoyer	0132-0702	Discontinued, non CE marked
	France	0132-0703	Discontinued, non CE marked
	Italian	0132-0704	Discontinued, non CE marked
	Dutch	0132-0709	Discontinued, non CE marked
1	Front case spares kit containing: Front case, Syringe clamp assy, Button moulded (x2), Size sensor flag spares kit, Foam spacer type 3 (x2), Instruction leaflet, Radius Gauge, Case Templates and Screws M4x12 (x6)	0132-0101	
2	Rear case spares kit Kit contains the following parts: Rear case, Foam spacer, Foam spacer type 2 (x3), Rubber feet (x2), Screws M4x12 (x6) and Instruction leaflet	0132-0104	
3	Membrane front panel label		
	English	0132-0007	
	German	0132-0054	
	Australian	0132-0007	same as English
	Zeneca	0132-0007	same as English
	Hoyer	0132-0061	
	Dutch	0132-0007	same as English
	French	0132-0064	
	Italian	0132-0066	
4	Rear panel instruction label		
	CE marked English	0132-0008	
	Non CE marked English	0132-0091	
	CE marked German	0132-0052	
	Non CE marked German	0132-0109	
	Non CE marked Hoyer	0132-0062	
	Non CE marked Dutch	0132-0091	same as English label
	Non CE marked French	0132-0065	
	Non CE marked Italian	0132-0067	

Figure 7.1 General assembly (contd)

Item	Description	Part number	Remarks
5	Case screws	5001-0345	6 required
6	Motor and gearbox assembly	0132-0015	
7	Leadscrew assembly	0132-0086	See Fig. 7.4
8	Occlusion sensing assembly	0131-0067	
9	Support tube	0127-0047	
10	Plunger clamp assembly		See Fig. 7.2
11	Nearly empty flag kit	0131-0122	Two types of flag supplied
12	Syringe barrel clamp assembly	0131-0149	
13	Size sensor flag retainer kit	0131-0238	
	Kit contains: Size sensor flag, anchor plate assy and Size sensor spring		
14	Main PCB assembly	0132-0011	See Fig. 7.7
15	Regulator PCB assembly - AC Power	0130-0013	See Fig. 7.8
16	Transformer	0130-0021	AC Power only
17	Opto sensors board	0128-0090	
18	Size sensors PCB assembly	0130-0017	
19	Umbilical PCB assembly	0132-0016	See Fig. 7.10
20	Pole clamp assembly		
	Non rotating pole clamp	0131-0129	See Fig. 7.3a
	Rotating pole clamp	0131-0083	See Fig. 7.3b
21	Plunger clamp open flag	0127-0019	
22	Mains cable assembly - AC Power	0053-0646	Internal; two wire
23	Power cable assembly	0053-0680	PL11 (Regulator board) to PL6 (Umbilical board)
24	Battery, cyclone; type 0801-000	3420-2120	3 required
25	Cable clamp	0127-0043	
26	Cordset		
	UK	3700-0046	
	English with Euro plug	3700-0035	
	Australian	3700-0056	
	AC power; 110 V	3700-0230	
	German	3700-0035	
	French	3700-0035	
	Italian	3700-0025	Without plug
	Dutch	3700-0044	
	Hoyer	3700-0035	
	German (Braun Perfusor)	3700-0035	
27	Instruction Manual		
	English	0132-0044	
	German	0132-0079	

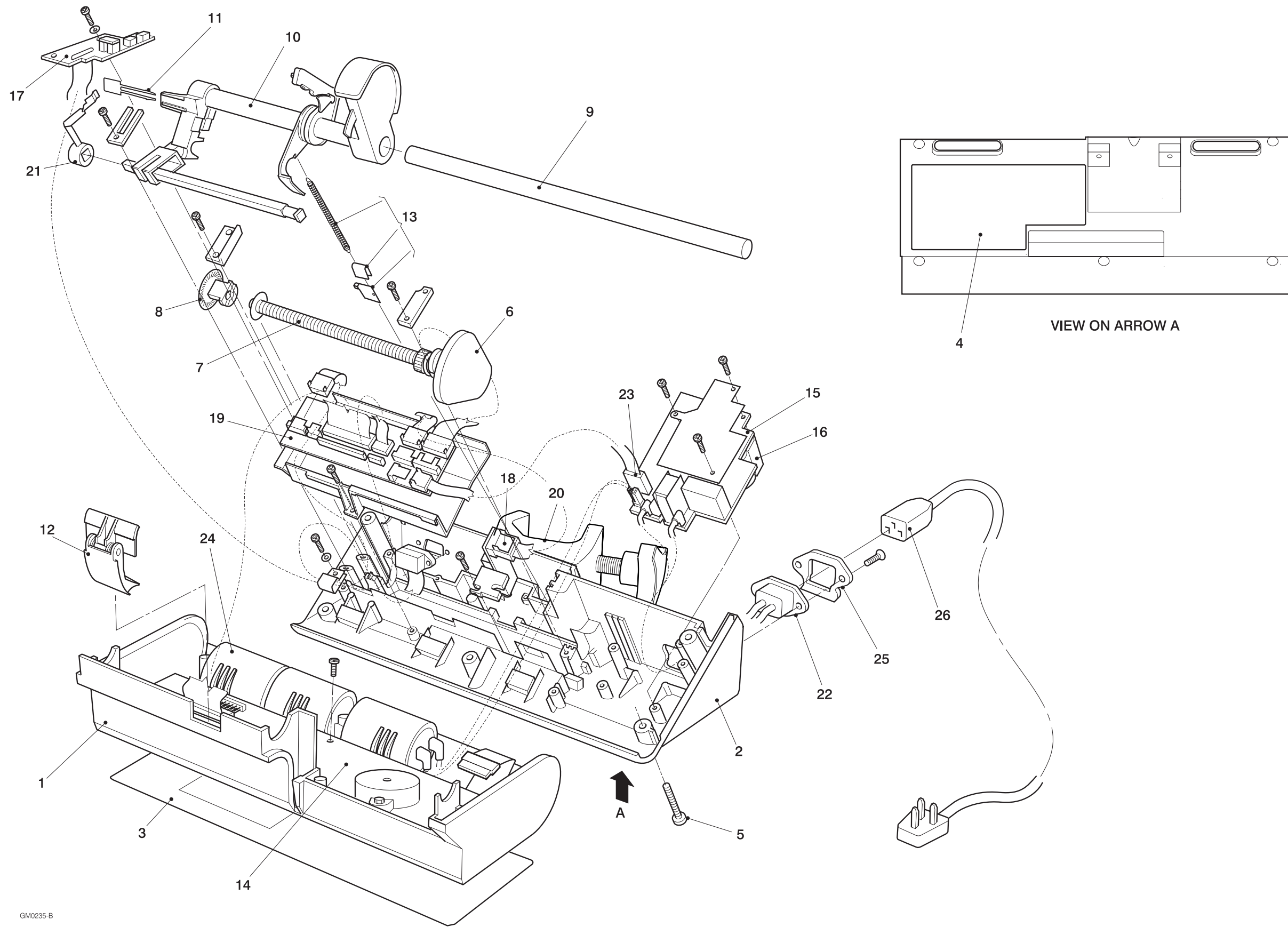

GM0235-B

Figure 7.1 General assembly

Figure 7.1 General assembly (contd)

Item	Description	Part number	Remarks
—	Technical service manual	00SM-0132	Not illustrated
—	Size sensor gauge set	0131-0202	Not illustrated
	Kit contains the following items: 18 size sensor gauges.		
—	PC interface cable assembly	0053-0704	Not illustrated
—	Rear warning labels		Not illustrated
	UL label	0132-0092	110V N. America only
	Zeneca label	0132-0058	
	Syringe type label	0132-0073	French only
—	5/10 ml adaptor plate	0132-0076	Not illustrated
—	Braun Perfusor 50 ml conversion kit:	0131-0048	Not illustrated
	Kit contains the following items ... Perfusor spacer tube, Nearly empty flag for Perfusor, Plunger clamp plate, P' label		See Chapter 8 for conversion procedure
—	Dual ramp gauge	0131-0084	See page 6-4
—	Linear accuracy gauge	0131-0230	See page 6-5
—	Taper gauge	0131-0227	See page 6-5

Figure 7.2 Plunger clamp and half nut assemblies

Item	Description	Part number	Remarks
1	Plunger clamp and half nut assemblies Plunger clamp and tube	0127-0044	
2	Plunger clamp cover and internal kit Kit contains the following items: Plunger clamp cover, Plunger clamp lock, Plunger clamp pin, Plunger clamp conical spring, Plunger clamp finger spring	0131-0239	
3	Half nut casting	0132-0042	
4	Size sensor flag spares kit Kit contains the following items: Size sensor flag, Size sensor flag moulding, Protective cap, Grub screw M4 x 6, Size sensor shims (x4), 2 screws and Instruction leaflet	0137-0025	
5	Square shaft	0127-0048	

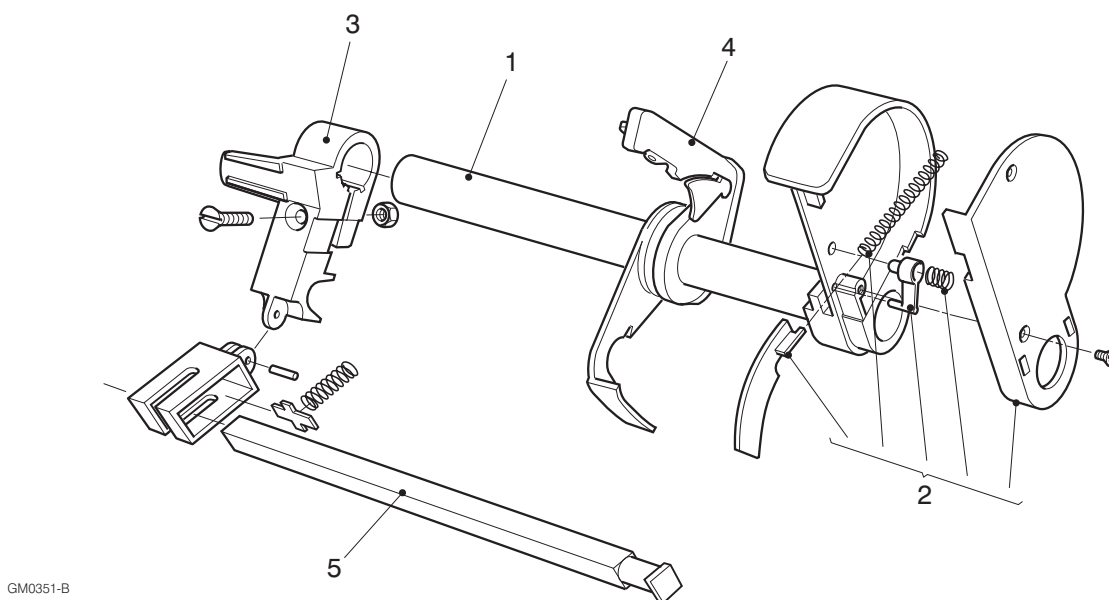
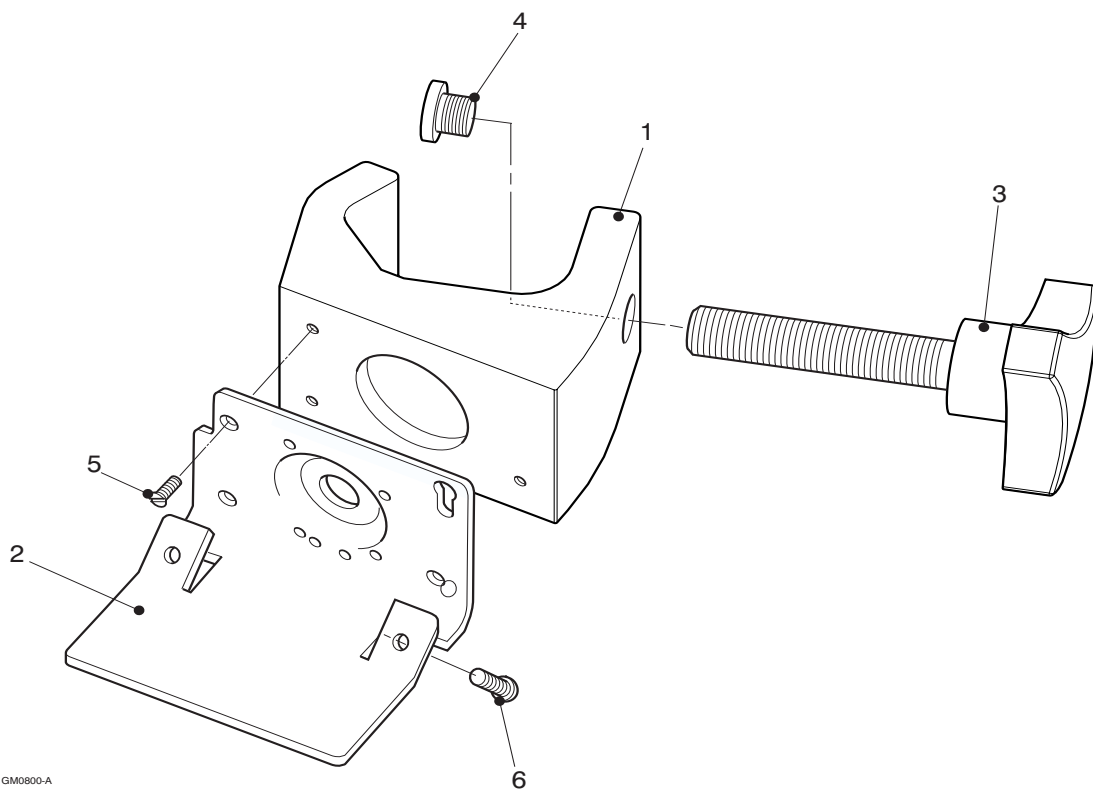

Figure 7.2 Plunger clamp and half nut assemblies

Fig. 7.3a Pole clamp assembly: non-rotating

Item	Description	Part number	Remarks
	Pole clamp assembly (new version)	0131-0129	See Fig. 7.3a



GM0800-A

Figure 7.3a Pole clamp assembly - Non-rotating

Fig. 7.3b Pole clamp assembly: rotating

Item	Description	Part No.	Remarks
	Rotating pole clamp assembly	0131-0083	
1	Securing plate	0131-0074	
2	Locating ring	0127-0064	
3	Handle	0127-0060	
4	Crescent circlip	5030-5710	
5	External circlip type 7100-010	5030-4010	
6	Spirol pin 3 x 26	5028-3408	
7	Clamp pad kit	0131-0052	
	Kit contains the following items: clamp bolt, clamp pad, spacer, end cap and screw M3 x 12.		

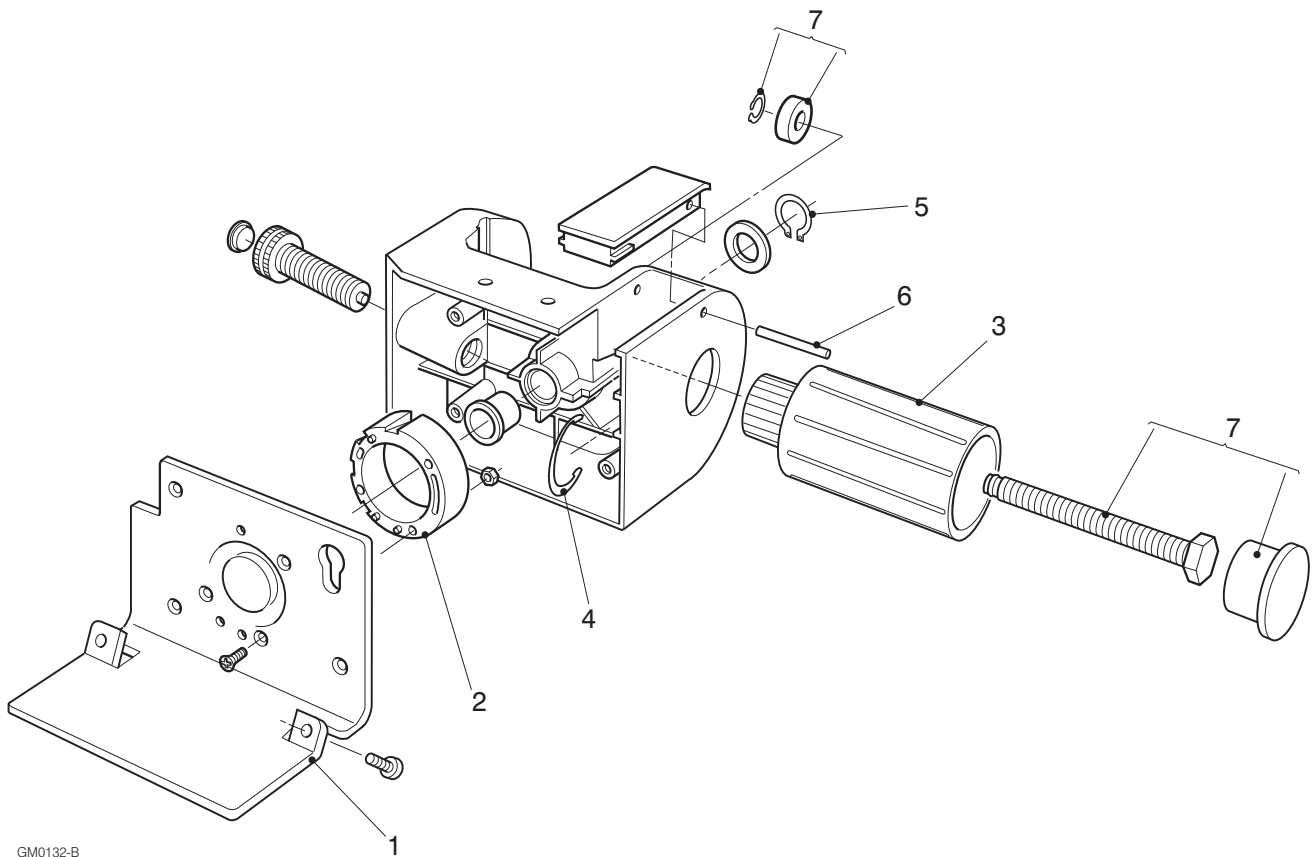
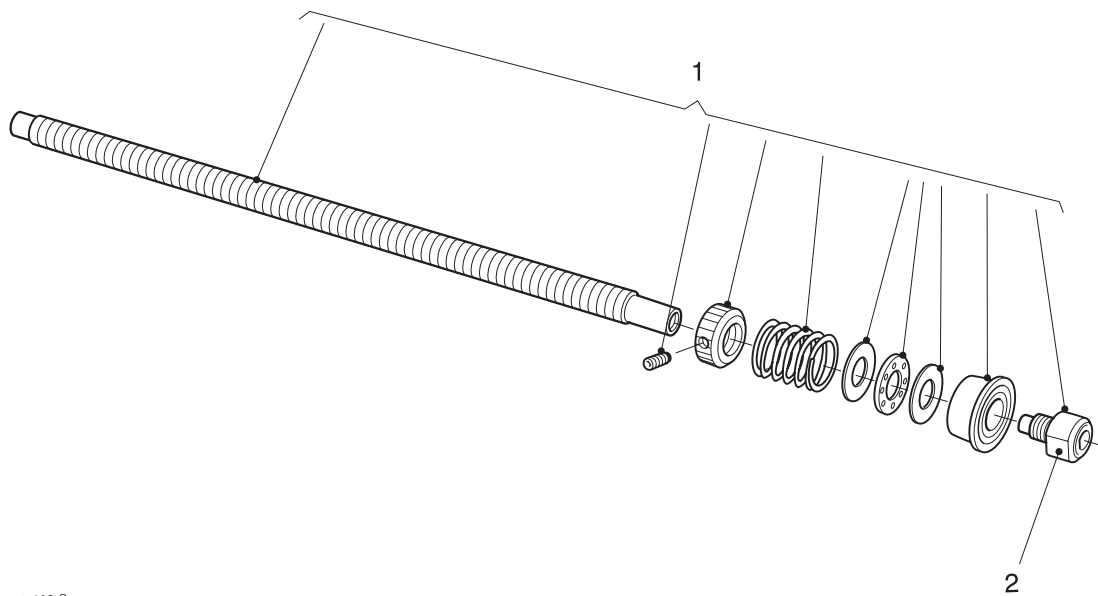

Figure 7.3b Pole clamp assembly - rotating

Figure 7.4 Leadscrew assembly

Item	Description	Part number	Remarks
1	Leadscrew sub assembly	0132-0086	
2	Leadscrew coupling	0127-0074	



GM0236-C

Figure 7.4 Leadscrew assembly

Figure 7.5 Opto sensors board assembly

Item	Description	Part number	Remarks
	<p>Opto sensors board assembly</p> <p>Note: The items below are for reference only and are not available as spare parts</p> <ul style="list-style-type: none"> Opto interrupter HOA 0875-051 Opto interrupter HOA 1882-012 Opto sensors cable assembly Sensors flag constraint 	0128-0090	<p>OPTO 1 and OPTO 2</p> <p>OPTO 0</p> <p>—</p> <p>—</p>

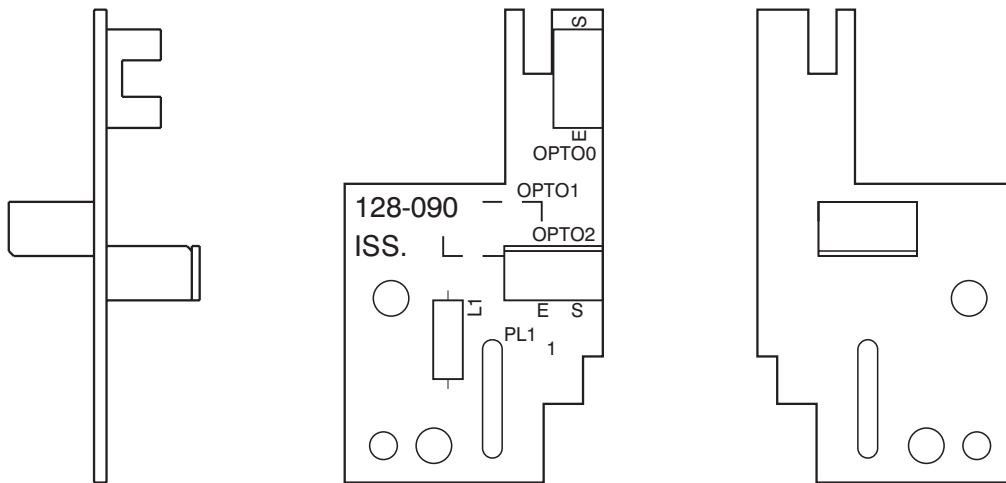

GM0397-A

Figure 7.5 Opto sensors board assembly

Figure 7.6 Size sensors board assembly

Item	Description	Part number	Remarks
	<p>Size sensors board assembly</p> <p>Note: The items below are for reference only and are not available as spare parts</p> <p>Size sensor moulding Infra-red emitting diode Photo-transistor Screw WN1442-KB25-6-Z Header 6 way 6410 Size sensor shim</p>	<p>0130-0017</p> <p>0130-0024 2424-1010 2425-3020 5017-9908 3750-7471 0130-0100</p>	<p>D1, D2 & D3 Q1, Q2 & Q3</p>

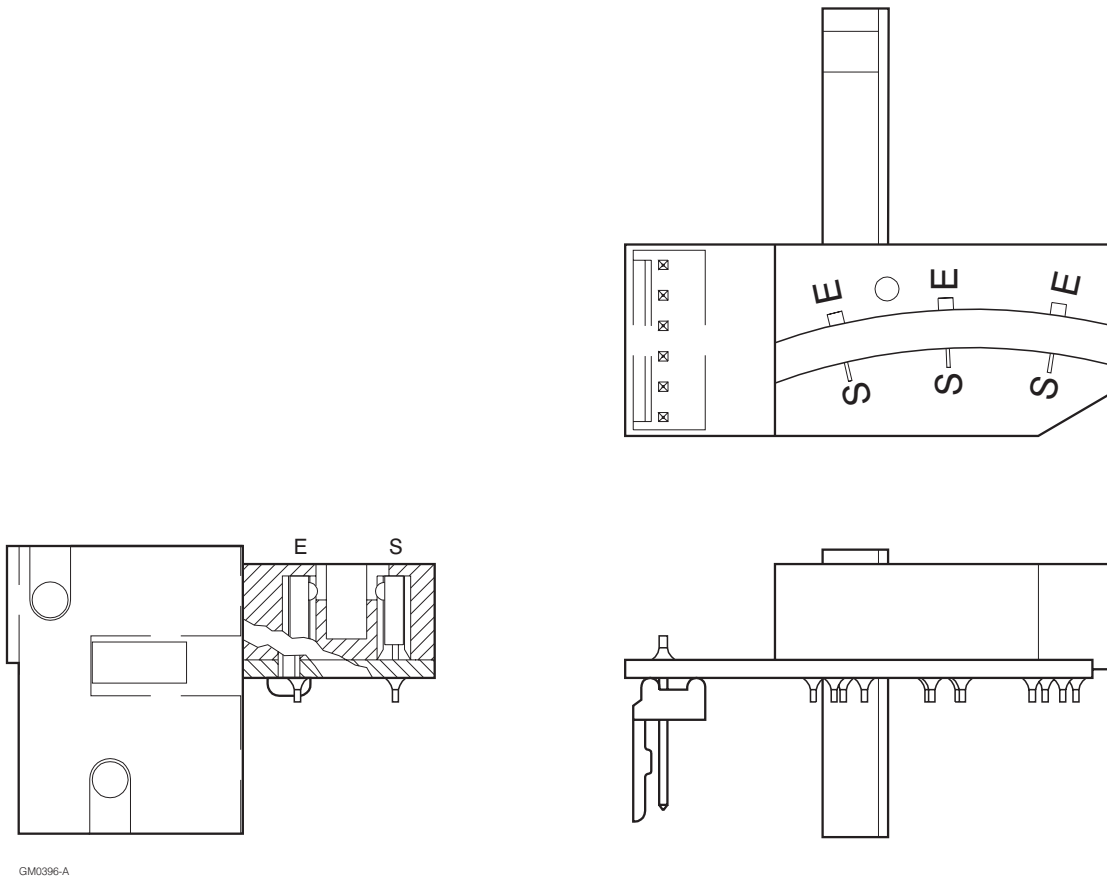
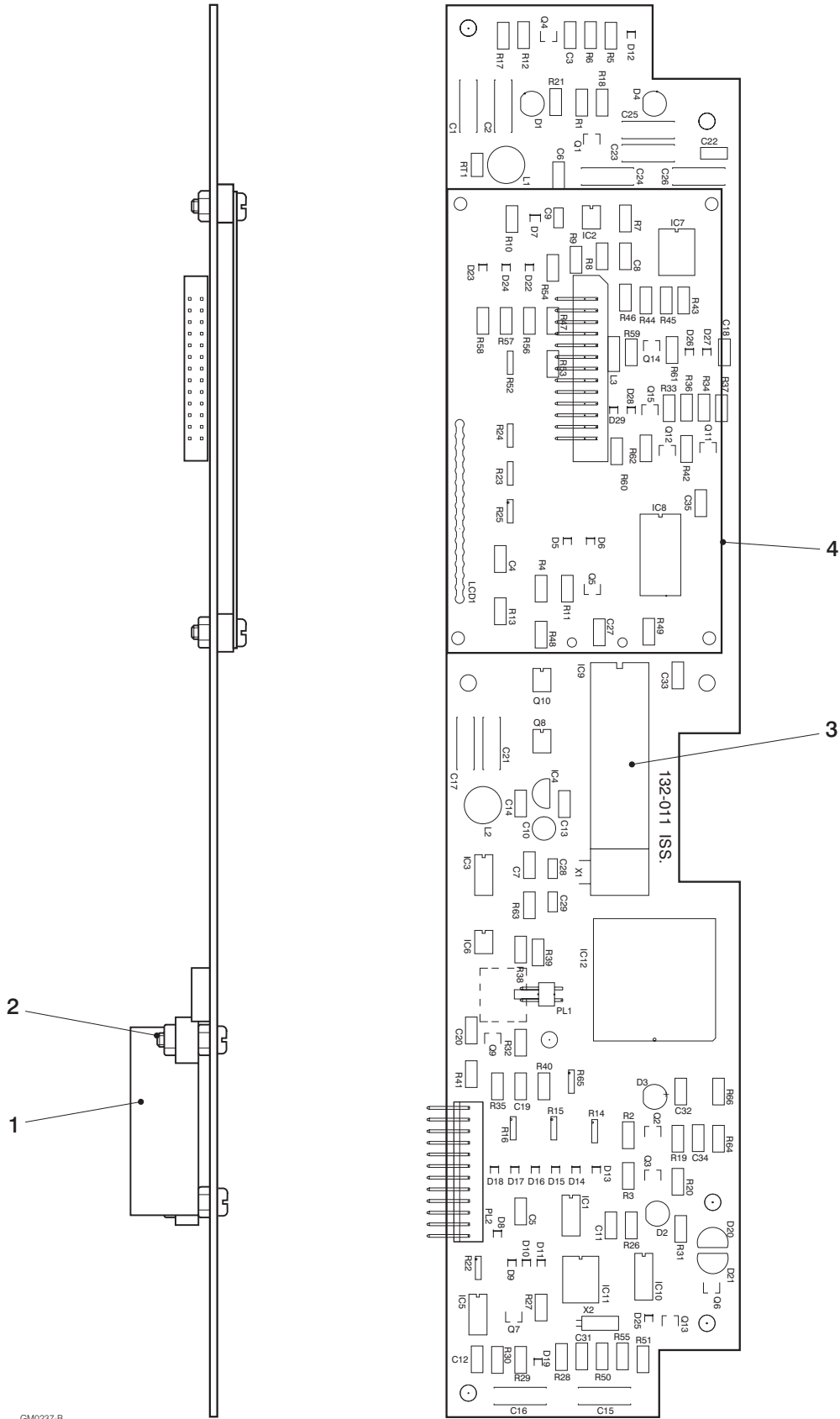

Figure 7.6 Size sensors board assembly

Figure 7.7 Main board assembly

Item	Description	Part number	Remarks
1	Main board assembly	0132-0011	
	Sounder	3430-1205	
2	Sounder restraint kit	0131-0240	
	Kit contains the following items:		
	Nut M3 - 2 off, screw M3 x 16 - 2 off, Pillar - 2 off		
3	IC9, Programmed EPROM	0132-0014	
4	Display LCD module MGLS19264GLED03	2432-7010	
Note: The items below are for reference only and are not available as spare parts			
	IC skt, 32 pin		
	Pillars for sounder, 4 off		
	Screw, M3 x 16, slot, pan head, 2 off		
	Nut, M3 hex full, nylon, 4 off		
	Spacer, nylon, 4 off		
	Housing, 2 way		
	Screw, M2 5 x 12 slot, pan head, 4 off		
	Nut M 2.5, full, nylon, 4 off		
	Terminal strip		
	Socket, strip		
	Self-adhesive pad, 1 off; under crystal		
	C1, C2, C15 to C17, C21 and C23 to C26, Capacitor, 10 μ F 16 V S/M, 10 off		
	C3 to C8, C11 to C14, C18 to C20, C22, C27, C31 to C35, Capacitor, 47nF S/M, 20 off		
	C9, C28 and C29, Capacitor, 22 pF S/M, 3 off		
	C10, Capacitor, 100 μ F 6.3 V		
	D1 and D2, LED yellow 3 mm		
	D3, LED green 3 mm		
	D4, LED red 3 mm		
	D5, D6, D12, D19 and D26 to D29, Diode rectifier, 8 off		
	D7, Diode rectifier		
	D8 to D11, D25, Diode rectifier, 5 off		
	D13 to D18 and D22 to D24, Diode Zener, 9 off		
	D20, Diode Zener		
	D21, Diode Zener		
	IC01, IC MC74HC164D Motorola		
	IC02, Regulator MAX4391CSA		
	IC03, IC S/M 74HC00D		
	IC04, IC Volt Reg +5 V Maxim		
	IC05, IC MC14093BD Motorola		
	IC06, IC op amp		
	IC07, IC MAX232CWE Maxim		
	IC08, IC HM62256LF10 Hitachi		
	IC09, EPROM M27C1001		
	IC10, IC MAX691ACSE Maxim		
	IC11, IC DS Dallas 1202 S		
	IC12, IC MC68HC11K1CFN4		
	L01, Inductor, 220 μ H		
	L02, Inductor, 1 mH		
	L03, Inductor, bead		
	PL01, Header 2 way		
	PL02, Header 12 way		
	PL03, Header 26 way, dual row		
	Q01 to Q07, Q09, Q11 and Q13 to Q15, Transistor, 12 off		
	Q08 and Q10, Transistor, 2 off		
	Q12, Transistor		



GM0237-B

Figure 7.7 Main board assembly

Figure 7.7 Main board assembly (contd)

Item	Description	Part number	Remarks
	<p>R01 to R04, R27, R29, R30, R32, R39, R45, R46, R50, R55 to R60, R64 and R66, Resistor, 10K, 5%, 1/8 W, 20 off</p> <p>R05, R33, R34, R35, R43, R44, R47, R53 and R54, Resistor, 1K, 5%, 1/8 W, 9 off</p> <p>R07, R08 and R51, Resistor, 47K, 5%, 1/8 W, 3 off</p> <p>R09 and R10, Resistor, 150K, 5%, 1/8W, 2 off</p> <p>R11, Resistor 6R8, 5%, 1/4 W</p> <p>R12, Resistor 910R, 5%, 1/8 W</p> <p>R13, Resistor 100R, 5%, 1/8 W</p> <p>R14, R15, R16 and R65, Resistor 10K, 4 off</p> <p>R17, R36 and R37, Resistor 4K7, 5%, 1/8 W, 3 off</p> <p>R18 to R21, Resistor 470R, 5%, 1/8 W, 4 off</p> <p>R22 to R25, and R52, Resistor 100R, 5 off</p> <p>R26, R28 and R31, Resistor 100K, 1%, 1/8 W, 3 off</p> <p>R38, Resistor 220K, 5%, 1/8 W</p> <p>R40, Resistor 120R, 5%, 1/8 W</p> <p>R41, Resistor 1K5, 5%, 1/8 W</p> <p>R42, Resistor 100R, 5%, 1/8 W</p> <p>R48 and R49, Resistor 11K, 1%, 1/8 W, 2 off</p> <p>R61 and R62, Resistor 47R, 5%, 1/4 W, 2 off</p> <p>R63, Resistor 10M, 5%, 1/8 W, 2013-7560</p> <p>R67, Potentiometer 4K7</p> <p>X1, Crystal 16 MHz</p> <p>X2, Crystal 32.768 kHz</p> <p>RT1, Thermistor NTC 100K</p>		

Figure 7.8 Regulator board assembly - AC Power

Item	Description	Part number	Remarks
1	Regulator board assembly	0128-0013	
	Fuse cover	3412-0228	
2	FS1, Fuse 500 mA 5 x 20 mm, UL-BUSSMANN S500	3410-3705	
3	FS2, Fuse 1A 5 x 20 mm	3410-3003	
4	FS3, Fuse 2A 5 X 20 mm, UL-BUSSMANN S500	3410-4505	
Note: the items below are for reference only and are not available for spare parts			
	PSU Fuse shield RF Screen assy Heatsink Screw M3 x 8 pozi, pan head - 2 off Nut M3 hex - 2 off Insulating bush - 2 off Insulating washer - 2 off Washer M3 crinkle - 2 off Pin terminal - 2 off Transformer, T1 - AC power Q1, Tran thyristor 5 A 200 V Q2, BC184L Q3, BUZ80 PL1 and PL2, Tab spade - 2 off PL11, Header 4 way PL12, Header 2 way C1, 22 pF 2% 100 V C2, 47 pF 2% 100 V C3 and C4, 220 pF - 2 off C5 - Not used C6, 2µ2 63 V Elec C7, 1000 µF 10 V C8, 1.0 nF 10% 100 V C9, 1nF 10% 100V C10, 47 µF 400 V Elec C11, 10 nF 63 V C12, 10 nF 10% 100 V C13, 1 µF 20% 25 V C14, 100 nF 250 V D1 and D5, Schottky 11DQ10 - 2 off D2, Zener 13 V 5% 1.3 W D3, Schottky 7.5 A 45 V D4, TL431CLP D6, Zener 13 V 5% 5 W D7, Bridge rect 1.5A 600 V D9, Zener 6v2 5% IC1, HV9120P IC2, Optocoupler CNY17F-3 L2, Ind 2X47MH RV1, Potentiometer 470R R1 to R4 and R11, Res 220R 5% 1/8 W - 5 off R5, Res 27R 5% 1/8 W R6 and R7, Res 10 K 5% 1/8 W R8, Res 1K2 5% 1/8 W		

Figure 7.8 Regulator board assembly - AC power (contd)

Item	Description	Part number	Remarks
	R13, Res 390K 5% 1/8 W R14, Res 330K 5% 1/8W R15, R19, R25, Res 4K7 5% 1/8 W - 3 off R16, Res 470R 5% 1/8W R17, Res 1R8 5% 1/4 W R18, Res 47K 5% 1/8W		

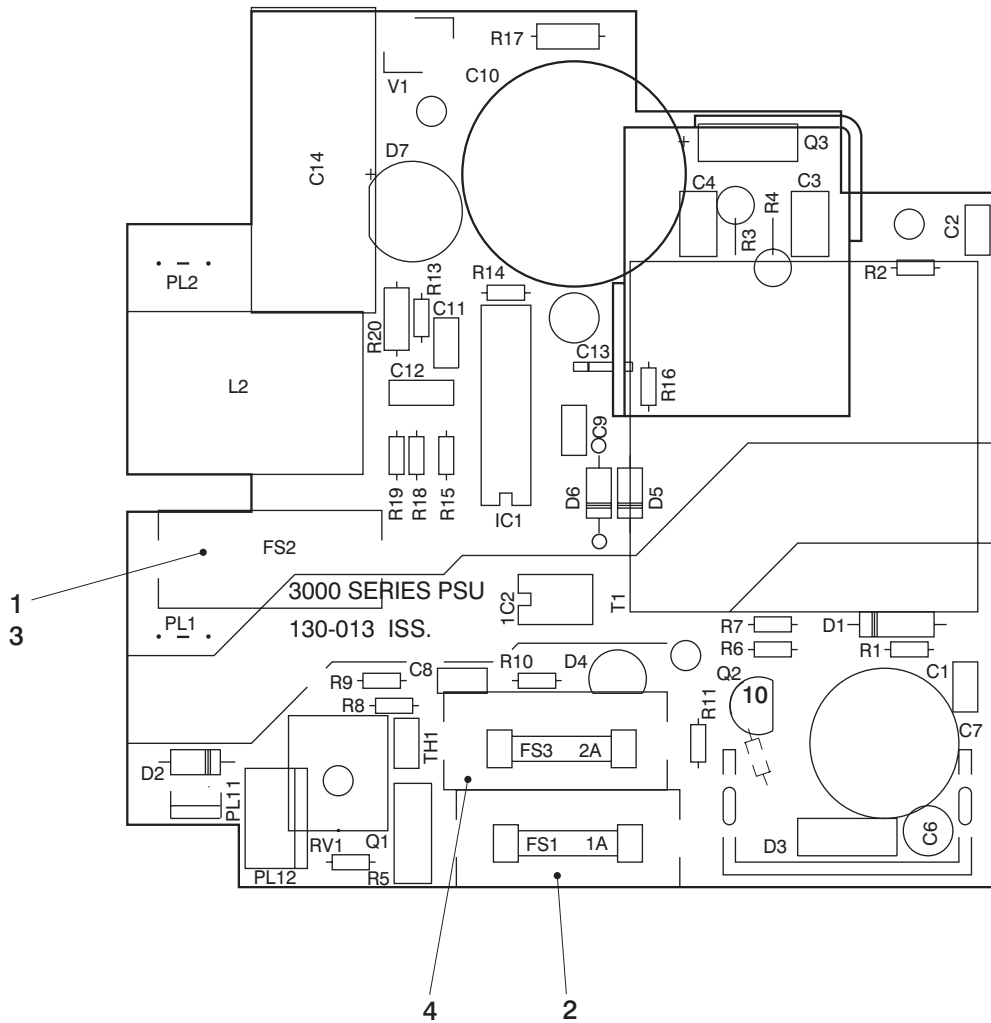

GM0399-B

Figure 7.8 Regulator board assembly

Figure 7.9 Distribution board assembly

Item	Description	Part number	Remarks
	Distribution board assembly Note: The following items are for reference only and are not available for spare parts Connector INC 26 way Ribbon cable 26 way PL1, header 26 way dual row PL2, header 10 way dual row PL3 and PL7, header 6 way PL4, header 7 way PL5, header 3 way PL6, header 4 way	0132-0016	

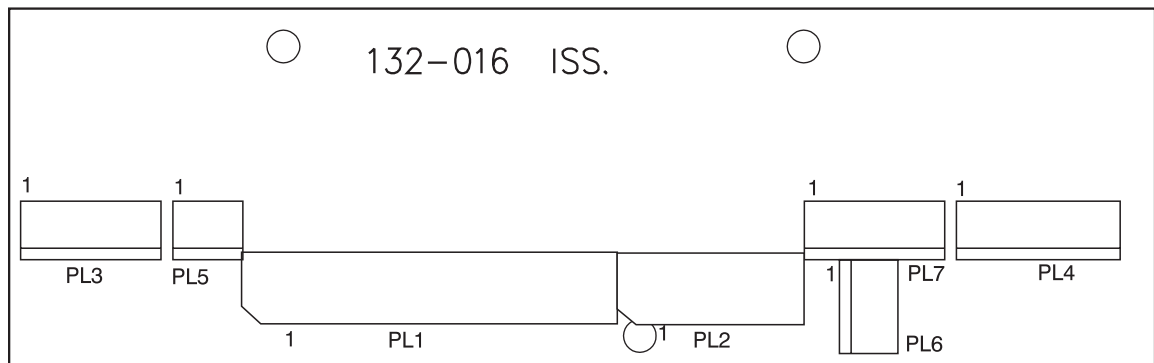

GM0342-A

Figure 7.9 Distribution board assembly

CHAPTER 8

BRAUN PERFUSOR CONVERSION

3400
ANAESTHESIA SYRINGE PUMP

CHAPTER 8

BRAUN PERFUSOR CONVERSION

Syringe conversion procedures

Introduction	The 3400 can easily be converted, if required, in order to use the 'Braun Perfusor 50 ml syringe'. The Perfusor conversion kit part number is 0131-0048. The conversion procedures are detailed below and are shown in Figure 8.1.
Nearly empty flag conversion	<p>Open the pump case (page 2-5) and temporarily displace the Distribution board assembly (Fig. 7.1) by unscrewing the screw at the bottom of the assembly.</p> <p>Remove the standard flag from the top of the half nut (retain the standard flag for possible future use). Fit the elongated Perfusor 50 ml nearly empty flag by inserting the flag into the grooves on the half nut (see Fig. 8.1). Ensure that the flag is fitted so that the small amount of flag bias is in the direction of the arrow shown in Figure 8.1.</p> <p>Note: If not already biased, bend/bias the end of the flag in the direction of the arrow shown in Figure 8.1 a distance of approximately 2 mm, this will ensure that the flag (when it moves fully to the left) does not touch the left hand post.</p>
Spacer tube fitment	Carefully lift up the left hand end of the inner metal tube and fit the nylon spacer tube (part number 0131-0051) over the tube. The spacer tube acts as an end of travel stop when the half nut assembly is moved to the left.
Plunger clamp fitment plate	Fit the self adhesive half-round plunger clamp plate (part number 0131-0073) to the left hand side of the plunger clamp. It must be fitted to the vertical face of the plunger clamp so that it covers both quadrant vanes (Fig. 8.1). Reassemble the case as detailed on page 2-5.
Braun perfusor selection	<p>The Braun Perfusor 50 ml syringe is selected for use (on the pump) by using a special Configuration command.</p> <p>First select the Configuration mode (see page 2-1) and then select and display the syringe brand screen.</p> <p>Simultaneously press the following three buttons:</p> <p style="text-align: center;">ALARM, BOLUS and OFF.</p> <p>The pump will then switch to the Braun Perfusor syringe mode and other syringe brands will automatically be disabled. The pump syringe display will show:</p> <p style="text-align: center;">BRAUN PERFUSOR 50 ml</p> <p>and the CHANGE button, whilst in this mode is ineffective.</p>
'P' label fitment	Fit the self adhesive 'P' label (part number 0131-0065) to the front of the pump in the area just above and to the right of the product name (Fig. 8.1). This label acts as a visual reminder that the pump must only be used with the Braun Perfusor syringe.

Reselecting 'various' syringe brands

Mechanical procedures

To reselect the various syringe brands carry out the following mechanical and programming procedures:

1. Take the case apart (page 2-5).
2. Replace the original standard nearly empty flag.
3. Remove the nylon spacer from the left hand side of the inner metal tube.
4. Remove the adhesive plunger clamp plate.
5. Reassemble the case.
6. Remove the adhesive 'P' label from the front of the pump.

Programming procedures

1. With the pump switched **ON** and

BRAUN PERFUSOR 50 ml

displayed within the Configuration mode (page 2-1), simultaneously press the following three buttons:

ALARM, BOLUS and OFF

in order to set the Configuration mode so that the various brands of syringe may be selected.

2. Set the pump to the brand of syringe that is going to be used and then press the **STOP** button in preparation for the next infusion.

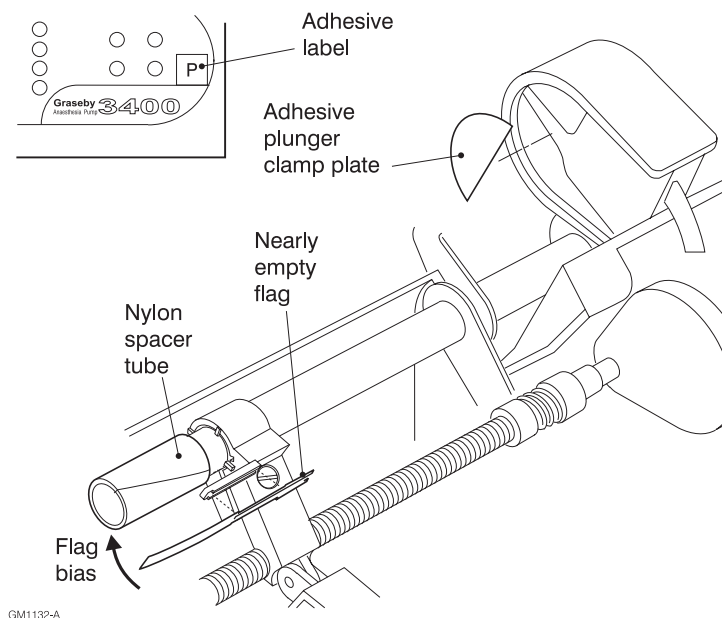

Figure 8.1 Braun Perfusor conversion: parts required

APPENDIX

FITMENT OF NEW MODIFIED SIZE SENZOR FLAG

3400

ANAESTHESIA SYRINGE PUMP

APPENDIX

FITMENT OF NEW MODIFIED SIZE SENSOR FLAG

INTRODUCTION

In a continual and ongoing programme of improvements to their 3000 range of syringe pumps, SIMS Graseby engineers have recently introduced a modified Syringe Size Flag (SSF), see Fig. A.1, that allows the size sensor mechanism to be accurately aligned.

On recently manufactured 3400 pump's a new thicker size sensor opto moulding and two associated longer fixing screws have been introduced, at the same time as the modified SSF, in order to make the alignment procedures easy.

This appendix will enable a qualified Technician to fit the new SSF; the associated SSF shim/s; if required the fitment of the new thicker size sensor opto moulding, and to carry out the final test procedures.

The SSF and shims etc. that will be required to modify a 3400 pump are supplied in kit form (part No. 0137-0025), and this spares kit will include the following:

- SSF, Part No. 0132-0090 (see Figure 1),
- 0.6 mm thick shim, Part No. 0130-0107,
- 1.0 mm thick shim, Part No. 0130-0108,
- 1.2 mm thick shim, Part No.0130-0190,
- 1.4 mm thick shim, Part No. 0130-0185,
- opto moulding, Part No. 0130-0024 (4.65 mm thick),
- screws, No. 4 x 5/8 inch, Pozi, self-tap, 5017-3410 (2 off),
- M4 x 6 nylon grub screw, Part No. 0131-0144,
- tamper proof protective cap, Part No. 0131-0136,
- instruction leaflet, Part No. 0131-0217.

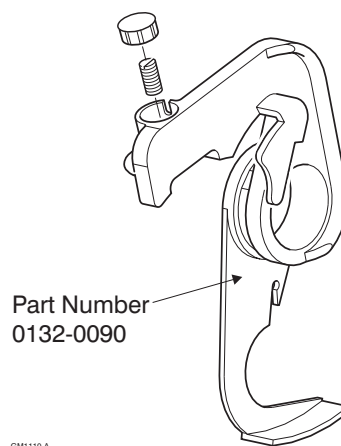

Figure A.1 New modified Syringe Size Sensor flag

WARNINGS

When a new SSF has been fitted to a 3400 pump, the pump must be tested using the Syringe Size Sensor gauges (Part No. 0131- 0202) available from SIMS Graseby. Page 3 gives details of the Final Testing procedures.

Ensure that the AC mains supply is switched off and the pump's AC connector is removed before opening the two halves of the case.

CAUTION

During the removal and replacement of a pump's components strict observance to Electro Static Discharge (ESD) rules must be observed at all times, i.e. an earthing strap must be worn. Failure to apply ESD protection may result in damage to the pump, resulting in its malfunction.

OPENING THE CASE

The screws, washers and associated items that are removed during the disassembly of the pump will be required during the reassembly.

1. Utilising a scratch free flat surface, turn the pump over in order to gain access to the base of the pump.
2. Undo the six screws that hold the two halves of the pump cases together.
3. Place the pump upright and from the top carefully ease the two halves of the casing apart, taking care not to put any strain on the internal connecting cable looms that form a hinge between the two halves of the case.

REMOVAL OF OLD SSF

1. With the pump case open as detailed above remove and retain the screw from beneath the umbilical board and displace the board in order to reveal the half-nut.
2. Disconnect the long thin spiral spring from its slot in the SSF, and pull out and remove the half-nut connecting pin.
3. Observing the position of the SSF in the rear of the case, and the position of the half-nut on the end of the large diameter support tube, lift the SSF and support tubes assembly up and away from the pump.
4. Remove the large half-nut screw, and then prise the half-nut apart and remove it from the support tube.
5. Slide the old replaceable SSF to the left, over and away from the small diameter support tube.
6. Remove connector PL1 from the size sensor opto moulding and also remove the two screws that hold the moulding in place.

Note:

The thickness of the size sensor opto moulding should be 4.65 mm (a new moulding and longer fixing screws are supplied in the SSF kit). If you have the old type moulding, i.e. 3.00 mm thick, then it may be difficult to obtain the correct syringe size sensor results when the new SSF is fitted. If difficulty is experienced then contact your local representative or SIMS Graseby, Service Department.

REASSEMBLY

Remove any shim/s that were attached to the size sensor opto moulding, and if required clean the shim area with a suitable solvent. The shim sizes provided in the kit are **0.6, 1.0, 1.2** and **1.4 mm**. If necessary, use a combination of shims to obtain the thickness required, up to a maximum of 2.4 mm. During production at SIMS Graseby a 1.6 mm shim is initially fitted.

Using the modified SSF, reassemble in reverse order to that given in 1 to 6 above, all the components that were disassembled.

Taking care not to trap any leads assemble the casing ensuring that the two case halves have snapped together and that the front and rear mating edges are equal and parallel. The six case screws should be tightened to a torque of between 70 and 75 cNM in the order shown below:

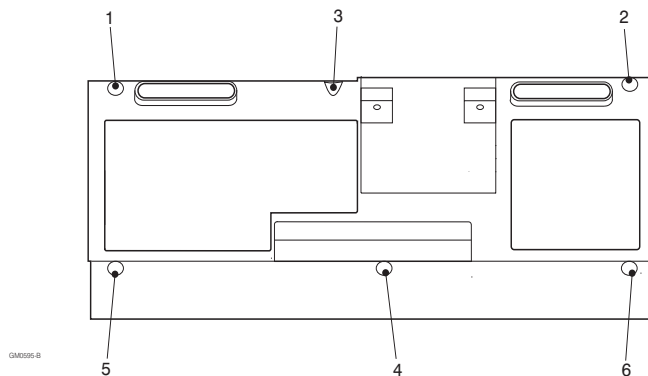

Figure A.2 Order for tightening the case screws

FINAL TESTING

When a new SSF has been fitted the pump must be subjected to the appropriate Functional Test procedures given in Chapter 6.

Before carrying out the Syringe Size Sensor tests ensure that the pole clamp has been correctly fitted and the six case securing screws have been fully tightened (see Fig. A.2).

The Syringe Size Sensor tests are performed with the pump's plunger clamp at each of the following positions:

1. 40 mm from the right-hand-side of the plunger clamp travel, and
2. at the extreme left-hand-side of the plunger clamp travel.

Also, the pump must be Configured during the tests to operate with the 'BD Plastipak' syringe.

The table given on page 5 lists the Gauges that must be sequentially loaded onto the pump in order to verify that the Syringe Size Sensor mechanism is operating correctly.

The small adjustment grub screw in the SSF must be correctly set (see page 4) before carrying out the Syringe Size Sensor tests, and the small anti-tampering cap above the grub screw must then be fixed into place using a minimal amount of Loctite 414.

SETTING THE SIZE SENSOR FLAG

1. Using the 3400 size sensor test gauges (see page 5) place the 20 ml minimum gauge (Part No. 131-170) into the pump's cradle.
2. If necessary rotate the adjustment screw until **20** appears on the display, and then rotate the adjustment screw counter-clockwise until **10** appears on the display. Now turn the adjustment screw very carefully clockwise until **20** is once again displayed.
3. Using the fingers, alternately apply and release, several times, a gentle pressure at point **X**, see figure A.3, on the size sensor flag, and ensure that the pump does **not** toggle between 10 and 20 ml. Fine tuning of the adjustment screw may be necessary to ensure that toggling does **not** occur.
4. Carry out the procedures outlined in paragraph 3 for each of the test gauges.
5. If during the tests the pump toggles between **20** and **30** when the 30 ml minimum gauge is in the cradle, then turn the adjustment screw clockwise until the pump no longer toggles between these values, and then carry out the full set of gauge tests again.

Note:

If during the syringe invalid test the pump toggles between **syringe invalid** and **5**, then this state is acceptable as long as the pump detects **syringe invalid** when the pressure is released, i.e. the flag is allowed to rest on the syringe invalid gauge.

The size sensor tests are complete when the correct display for each gauge appears and the pump does not toggle between sizes when pressure is applied to the flag.

Apply a small amount of Loctite 414 to the anti-tampering grub screw cap and then fit it into place.

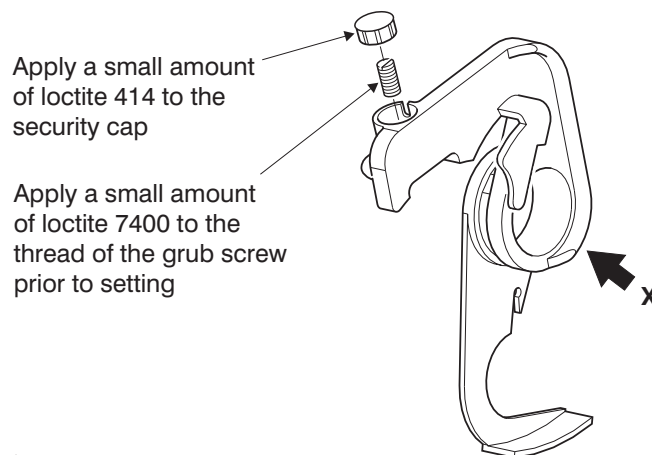

GM1111-A

Figure A.3 Size Sensor Flag: general details

The SIMS Graseby Size Sensor Gauge set (Part No. 0131-0202) contains the gauges that are used to carry out the Size Sensor tests on the 3400. These gauges are listed below:

3400 Syringe Size Sensor Gauges (white)

PART No.	GAUGE DIA. (mm)	CORRECT RESULT
131-165	11.20	SYRINGE INVALID displayed
131-166	12.50 - min.	Syringe size 5 displayed
131-167	15.00 - max.	Syringe size 5 displayed
131-168	16.20 - min.	Syringe size 10 displayed
131-169	18.20 - max.	Syringe size 10 displayed
131-170	21.00 - min.	Syringe size 20 displayed
131-171	23.00 - max.	Syringe size 20 displayed
131-172	23.70 - min.	Syringe size 30 displayed
131-173	26.80 - max.	Syringe size 30 displayed
131-174	29.00 - min.	Syringe size 60 displayed
131-175	33.10 - max.	Syringe size 60 displayed

IN AN EMERGENCY CONTACT:

***sims* GRASEBY**

SIMS Graseby Limited

Colonial Way, Watford, Herts , UK, WD2 4LG

Tel: (+44) (0)1923 246434 Fax: (+44) (0)1923 231595 Web: www.graseby.co.uk

sims SMITHS INDUSTRIES
Medical Systems

Part No. 00SM-0132 Issue 6
July 2000

PRINTED ON RECYCLED PAPER

© SIMS Graseby Ltd. 2000

