

GLIDESCOPE®

Video Laryngoscopes



GlideScope GVL® and Cobalt User's Manual & Quick Reference Guide

GLIDESCOPE® Video Laryngoscopes



GlideScope GVL® and Cobalt Quick Reference Guide



Corporate Headquarters:

Verathon Inc.

20001 North Creek Parkway,
Bothell, WA 98011 USA
800.331.2313 (Canada and US)
425.867.1348
Fax: 425.883.2896
verathon.com



Verathon Medical (Europe) B.V.

Linnaeusweg 11
3401 MS, IJsselstein
The Netherlands
+31.30.68.70.570
Fax: +31.30.68.70.512
verathon.eu



Manufacturer

Verathon Medical (Canada) ULC

2227 Douglas Road
Burnaby, BC V5C 5A9
Canada
604.439.3009
Fax: 604.439.3039

For additional contact information please visit verathon.com.

GlideScope, the GlideScope symbol, GlideRite, GVL, Verathon, and the Verathon Torch symbol are trademarks of Verathon Inc. All other brand and product names are trademarks of their respective owners.

The GlideScope® technology is covered under US Patents (6,655,377) (6,543,447) as well as European Patent 1307131. Additional patents pending.

Information in this User's Manual and Quick Reference Guide may change at any time without notice. For the most up-to-date information, see the online manuals on verathon.com.

GlideScope video laryngoscope systems are CE marked in accordance with the Medical Device Directive, and the Verathon Inc. quality system is Quality System Certified to ISO 13485:2003 standards.

© 2009–2011 Verathon Inc. No part of this manual may be copied or transmitted by any method without the express written consent of Verathon Inc.

GlideScope System Quick Start

1 The monitor may be used immediately by plugging it into an AC power source, or by fully charging the battery prior to first use.

2 To ensure proper charging, follow these steps *in order:*

- Make sure the AC power cord is disconnected and the power switch is in the OFF position.
- Slide the power switch at the back of the monitor to the ON position.
- Plug the monitor into an AC power source:
 - Insert the female end of the power cord into the port on the back of the monitor.
- The charge status LED will turn orange, indicating that the recharging cycle has begun.
- When charging is complete, the status LED will turn green. At this point the unit is fully functional on battery power.



If the AC power cord is inserted before the power switch is in the ON position, the charge status LED will flash orange.

3 Connect the video laryngoscope to the monitor.

- If using the GVL®:
Connect either end of the video cable to the GVL connector. Connect the video cable to the monitor connector.





GlideScope System Quick Start

- If using the Cobalt system:
Connect the video baton to the monitor as shown in step #3. Then slide a single-use GVL Stat over the video baton.



To detach a GVL Stat from a Cobalt video baton, grasp the base of the video baton and pull firmly.

IMPORTANT! A used GVL Stat is a biohazard and should be disposed of in compliance with local protocols.

LED State	Meaning
Steady green  CHARGE STATUS	The battery is fully charged and ready for use.
Flashing orange  CHARGE STATUS	Flashing orange can indicate two states: <ul style="list-style-type: none"> If the AC power is connected and the power switch is off ("O" - to the left), the CHARGE STATUS LED will flash orange. The monitor will still function but the battery will not charge. If the AC power is NOT connected and the CHARGE STATUS LED flashes orange, the battery is malfunctioning.
Steady orange  CHARGE STATUS	Charging in progress

Corporate Headquarters:
Verathon Inc.
20001 North Creek Parkway
Bothell, WA 98011, USA
Tel: 800.331.2313 (US and Canada only)
Tel: 425.867.1348 Fax: 425.883.2896

Manufacturer:
Verathon Medical (Canada) ULC
2227 Douglas Road
Burnaby, British Columbia
Canada, V5C 5A9

EC Representative:
Verathon Medical (Europe) B.V.
Linnaeusweg 11
3401 MS IJsselstein Netherlands
Tel: +31.30.68.70.570

 **VERATHON**
MEDICAL
verathon.com

Cleaning and Disinfecting the GlideScope GVL and Cobalt Video Baton

- **DO NOT expose to temperatures above 60°C (140°F).**
Do not disinfect using devices such as autoclaves, ultrasonic cleaners or pasteurizers.
- The GlideScope GVL® is a nonsterile, reusable device. It is required that the GlideScope GVL is cleaned and disinfected after every patient use using a High Level Disinfectant method.
- The GlideScope Cobalt video baton is a nonsterile, reusable device. When used as intended, it is protected from direct contact with the patient by the sterile, single-use GVL Stat. Low Level Disinfection is recommended for the video baton after every patient use. High Level Disinfection is required for the GlideScope Cobalt video baton when it is visibly soiled.

1 Disconnect the GVL or video baton from the monitor.

2 Place the cleaning cap over the connector as shown.

- During cleaning, the protective cap must be inserted as shown to protect the cable connector.

GVL



Cobalt video baton



3 Wash the GVL or video baton manually to remove all foreign material from the surface of the device.

- Chemical compatibility and disinfection methods are detailed in the user's manual.
- To clean the exterior of the monitor and the video cables, wipe with IPA (70% isopropyl alcohol) bleach (100ppm) or a mild detergent and water.
- Wipe the cradle with a standard hospital-grade surface cleaning product.

For more detailed cleaning instructions see the GlideScope GVL/Cobalt User's Manual.

Attaching/Detaching the GlideScope GVL or Cobalt Video Baton

- 1 Insert the GVL® or Cobalt video baton cable into the port located on the face of the monitor so that the arrows on the cable and the monitor line up.
- 2 For GVL only: Attach the opposite end of the video cable to the port located on the GVL.

Note: When connecting and disconnecting the cable, grasp the connector by the gray sleeve.



Attaching/Detaching the GlideScope Cobalt Video Baton and Stat

- 1 Insert the Cobalt video baton into the sterile, single-use GVL Stat until it clicks into place. Ensure proper insertion by matching the GlideScope logo on the side of the video baton and the GVL Stat.
- 2 Detach the video baton from the GVL Stat by grasping the base of the video baton and pulling firmly.



IMPORTANT! A used GVL Stat is a biohazard and should be disposed of in a manner consistent with local directives in the user's jurisdiction.

Corporate Headquarters:
Verathon Inc.
20001 North Creek Parkway
Bothell, WA 98011, USA
Tel: 800.331.2313 (US and Canada only)
Tel: 425.867.1348 Fax: 425.883.2896

Manufacturer:
Verathon Medical (Canada) ULC
2227 Douglas Road
Burnaby, British Columbia
Canada, V5C 5A9

EC REP
EC Representative:
Verathon Medical (Europe) B.V.
Linnaeusweg 11
3401 MS IJsselstein Netherlands
Tel: +31.30.68.70.570
Fax: +31.30.68.70.512f

VERATHON
MEDICAL
verathon.com

The GlideScope 4-Step Technique



Looking directly into the patient's mouth and with the GlideScope in the left hand, introduce the video laryngoscope into the midline of the oral pharynx.



With the laryngoscope inserted, look to the monitor to identify the epiglottis, then manipulate the scope to obtain the best glottic view.

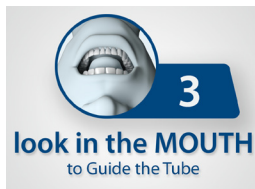

Looking directly into the patient's mouth, not at the screen, carefully guide the distal tip of the tube into position near the tip of the laryngoscope.

It is important to look into the mouth at this step to avoid injuring the tonsils or soft palate.



Look to the monitor to complete the intubation; gently rotate or angle the tube to redirect as needed.

- Verathon® recommends inserting the GlideScope video laryngoscope down the midline of the tongue to the epiglottis.
- The GlideScope video laryngoscope may be used to produce a Macintosh indirect lift of the epiglottis or a Miller lift.
- Intubations using GlideScope video laryngoscopes require approximately 0.5–1.5 kg of lifting force.
- Use of an endotracheal tube stylet is recommended. The GlideRite® Rigid Stylet is designed to complement the angle of the GlideScope video laryngoscope to facilitate intubation. A malleable stylet may be used with a 60–90° angle.



- To aid the passage of the endotracheal tube, withdraw the stylet (approx. 5 cm) while gently advancing the ETT. A 1 cm adjustment (withdrawal) of the laryngoscope also may be beneficial to reduce the viewing angle and allow the glottis to drop.

Corporate Headquarters:
Verathon Inc.
20001 North Creek Parkway
Bothell, WA 98011, USA
Tel: 800.331.2313 (US and Canada only)
Tel: 425.867.1348 Fax: 425.883.2896

Verathon Medical (Canada) ULC
2227 Douglas Road
Burnaby, British Columbia
Canada, V5C 5A9

Verathon Medical (Europe) B.V.
Linnaeusweg 11
3401 MS IJsselstein Netherlands
Tel: +31.30.68.70.570
Fax: +31.30.68.70.512

 **VERATHON**
MEDICAL
verathon.com

Important Information

Statement of Prescription

Federal (USA) law restricts this device for sale by or on the order of a physician.

The GlideScope video laryngoscope system should be used only by individuals who have been trained and authorized by a physician, or by health care providers who have been trained and authorized by the institution providing patient care.

Intended Use

GlideScope video laryngoscopes are intended for use by qualified medical professionals to obtain a clear, unobstructed view of the vocal cords for medical procedures.

Warnings and Cautions

Caution. Risk of permanent equipment damage.

Do not expose GlideScope video laryngoscopes or Cobalt video batons to temperatures above 140° F (60° C). Do not disinfect GlideScope video laryngoscopes or Cobalt video batons using devices such as autoclaves, ultrasonic cleaners, or pasteurizers. Use of such methods will cause permanent device damage and void the warranty.

Equipment Caution: Electrical shock hazard. Refer servicing to qualified personnel.

This equipment has been tested and found to comply with the standards listed in the Approvals section of this manual. These limits are designed to provide reasonable protection against harmful interference in typical medical installations.

CAUTION: Risk of equipment damage.

Failure to cover the cable connector port with the protective cap prior to cleaning may result in water ingress and potential device failure.

Bleach can be used on the baton but with special attention to the connector. Bleach may corrode the stainless steel inserts and damage the connector pins.

CAUTION: Potential interference with other devices.

GlideScope video laryngoscopes must be used with the supplied cables to maintain electromagnetic interference (EMI) within certified limits.

GlideScope GVL and Cobalt Systems

GlideScope GVL System



GlideScope Cobalt System

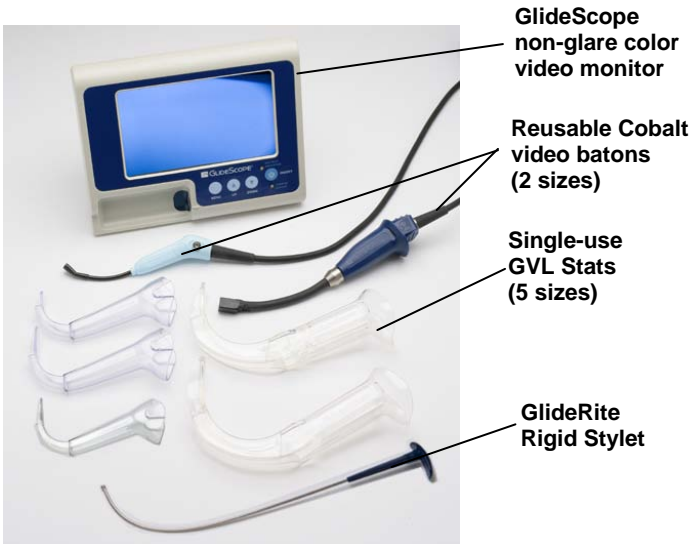

GlideScope Video Monitor Rear Panel



GlideScope Video Monitor Front Panel

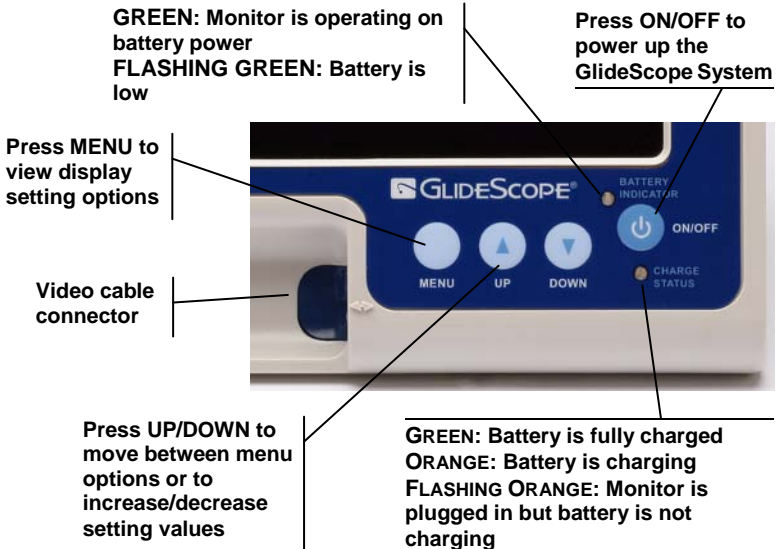

GlideScope System Configurations

The GlideScope system may be configured in one of three ways to best meet the needs of individual practices. Please refer to the User's Manual for complete assembly and setup information.



Mobile Stand



Hard Shell Case



Mounted on an IV Pole

Preparing for First Use

Prior to using the GlideScope system for the first time, perform the following steps:

1. Charge the monitor battery.
2. Set up the GlideScope system in your preferred configuration.
3. Attach a video laryngoscope or video baton to the monitor.
4. Connect the monitor to an external source such as a TV screen (optional).
5. Perform a functional check.
 - a. Connect a GlideScope video laryngoscope to the monitor (GVL® or Cobalt video baton + GVL Stat).
 - b. Turn the system on by pressing the ON/OFF button located on the face of the monitor.
 - c. Observe the monitor screen to verify that an image is being received from the GlideScope.

If the GlideScope GVL®, video baton, or Stat are stored in cold conditions, additional warming time may be required for optimal performance of the anti-fog feature.

Cleaning, Disinfecting, and Maintenance

To ensure patient safety, users should perform a routine inspection of the GlideScope video laryngoscope before every use to ensure that all endoscopic components are free of unintended rough surfaces, sharp edges, protrusions, or cracks.

If inspection reveals any faults in the components, contact Verathon Medical Customer Care or your local GlideScope representative. All repairs must be performed by an authorized Verathon Medical Service Center.

CAUTION: Risk of permanent device damage!

Do not expose GlideScope video laryngoscopes or Cobalt video batons to temperatures above 140° F (60°C).

Note: GlideScope GVL and Cobalt video baton laryngoscopes designed to better withstand vaporized hydrogen peroxide are identified by the metal label.



General Cleaning and Disinfection Information

Table 1: Risk Assessment

Device	Sterile	Use	Spaulding's CDC Classification	Disinfection			Sterilization
				Low Level	Int. Level	High Level	
GVL®	Non-sterile	Reusable	Semicritical			X	
GVL Stat	Sterile	Single use	Semicritical				
Cobalt video baton*	Non-sterile	Reusable	Noncritical	X			
Video cables	Non-sterile	Reusable	Noncritical	X			
Stylet	Non-sterile	Reusable	Semicritical			X	
Monitor#	Non-sterile	Reusable	Noncritical	X			
Cradle#	Non-sterile	Reusable	Noncritical	X			

It is understood that all items in this chart will be used as intended

Key:

- * The Cobalt video baton is a nonsterile, reusable device which is protected from contact with mucous membranes and nonintact skin by the Stat (sterile, single-use) when used as intended. Low Level Disinfection is recommended for the Cobalt video baton after every patient use. High Level Disinfection is required for the video baton when it is visibly soiled.
- # Disinfect monitor and cradle when they are visibly soiled and on a regular basis as per a schedule established by the medical care facility or provider.
- Shaded areas - not required/not compatible with device materials.
- Checked boxes (x) show minimum requirement.
- Unshaded areas show permissible levels of disinfection based on compatibility with device materials.

Warning: Disinfectants and cleaning methods listed are recommended by Verathon® based on compatibility with product materials. Refer to the label instructions for guidance on disinfection efficacy and appropriate clinical uses.

Caution: Meticulous cleaning must precede any disinfection process, to ensure all foreign matter is removed from the surface of the device. This allows the active ingredients of the chosen process to reach all the surfaces of the device.

Availability of cleaning products varies by country, and we are unable to test products in every market. Please use the list of recommended chemicals in this manual to compare with products available locally.

Note: When using any of the chemicals listed below, read and comply with product use instructions in all applications.

Table 2: Chemical Compatibility and Disinfection Methods for GVL®, Cobalt Video Batons and Video Cables

Active Ingredient	Compatibility	Conditions	Disinfection Level	Caution/ Comments
Enzymatic debridement agent/ detergent	General hospital grade	As per instructions	N/A	Surface cleaning only in preparation for disinfectant
Isopropyl Alcohol Solution	70%	70% used to wipe down with minimum 1 minute exposure	Low	
Hydrogen Peroxide	Up to 7.5%	7.5% – exposure for 30 minutes at $\geq 20^{\circ}\text{C}$ or as per manufacturer's instructions	High	
Vaporized Hydrogen Peroxide	90%	90% / 42 min	See comments on right	Compatibility has been established in vaporized hydrogen peroxide sterilization systems for ease of use
Glutaraldehyde	Up to 3.4%	2.0% – exposure for minimum 20 minutes at 20°C or as per manufacturer's instructions	High	
Ortho-Phthalaldehyde	0.55%	0.55% – exposure for 12 minutes at 20°C or as per manufacturer's instructions	High	
Peracetic Acid	0.2%	0.2% – exposure for minimum 12 minutes at 50 to 56°C or as per manufacturer's instructions	See comments on right	Classified as a chemical sterilant
Bleach (Sodium Hypochlorite)	Up to 8000ppm	5000ppm – exposure for 10 minutes at 20°C	High	Corrosive for connector pins and SS ring
		500ppm – used to wipe down with minimum 1 minute exposure	Low	Noncorrosive at $\leq 500\text{ppm}$

Table 3: Chemical Compatibility and Disinfection Methods for GlideRite® Rigid Stylet

Active Ingredient	Compatibility	Conditions	Disinfection Level	Caution/ Comments
Glutaraldehyde	Up to 3.4%	2.0% – exposure for minimum 20 minutes at 20°C or as per manufacturer's instructions	High	
Ortho-Phthalaldehyde	0.55%	0.55% – exposure for 12 minutes at 20°C or as per manufacturer's instructions	High	
Peracetic Acid	0.2%	0.2% – exposure for minimum 12 minutes at 50 to 56°C or as per manufacturer's instructions	See comments on right	Classified as a chemical sterilant
Isopropyl Alcohol Solution	70%	70% – exposure for 10 minutes at 20°C	Intermediate	
		70% used to wipe down with minimum 1 minute exposure	Low	
Bleach (Sodium Hypochlorite)	≤ 500ppm	500ppm – used to wipe down with minimum 1 minute exposure	Low	Noncorrosive at ≤ 500ppm
Enzymatic debridement agent/ detergent	General hospital grade	As per instructions	N/A	Surface cleaning only in preparation for disinfectant
N/A	Tested in autoclave (steam cycle)	Minimum 4 minute 132°C pre-vacuum steam sterilization cycle	See comments on right	Based on requests from users, an autoclave cycle has been established for the stylet for ease of use

Cleaning and Disinfecting the GVL and Cobalt Video Baton

Caution: Meticulous cleaning must precede any disinfection process, to ensure all foreign matter is removed from the surface of the device. This allows the active ingredients of the chosen process to reach all the surfaces of the device.

The GlideScope GVL® is a nonsterile reusable device. It is required that the GlideScope GVL is cleaned and disinfected after every patient use, using a High Level Disinfectant method.

The Cobalt video baton is a nonsterile, reusable device which is protected from direct contact with the patient by the Stat (sterile, single-use) when used as intended, Low Level Disinfection is recommended for the Cobalt video baton after every patient use. High Level Disinfection is required for the Cobalt video baton when it is visibly soiled.

CAUTION: Risk of equipment damage.

Bleach can be used on the baton but with special attention to the connector. Bleach may corrode the stainless steel inserts and damage the connector pins.

Availability of disinfection products varies by country, and we are unable to test products in every market. Please use the list of recommended disinfectants in the User's Manual to compare with products available locally.

For more detailed cleaning instructions see the GlideScope System User's Manual or visit glidescope.com.

Battery Replacement and Device Repair

Under normal operating conditions, the monitor battery will last 2 - 3 years; or approximately 500 charge/discharge cycles.

The battery is not user-replaceable. In case of battery malfunction, do not attempt to replace the monitor battery. Any attempts to replace the battery by unauthorized service technicians may cause serious harm to the user and will void the warranty. Please contact your Verathon Medical Customer Care Representative for more information on battery replacement.

Device Disposal

Disposal of this device can be coordinated through your Verathon Medical Service Center in accordance with WEEE requirements.

Specifications

General Specifications

Classification:	Electrical Class I, Applied Part BF
Line Voltage	Range: 100 – 240 VAC, 50 & 60 Hz
Line Current:	MAX 0.50 A
Power Plug:	Hospital Grade
Line Protection:	2A Fuse, Internal

Operation and Storage Conditions

Operating Conditions

Temperature:.....	10°C to 40°C
Relative Humidity:.....	0 to 95%
Atmospheric Pressure:.....	440 to 1060 hPa

Shipping and Storage Conditions

Temperature:.....	-20°C to 45°C
Relative Humidity:.....	0 to 95%
Atmospheric Pressure:.....	440 to 1060 hPa

Charging Conditions







Temperature:.....	0°C to 40°C
Relative Humidity:.....	0 to 95%
Atmospheric Pressure:.....	440 to 1060 hPa

Standards and Approvals

CMDCAS ISO 13485, Certificate No. 9235, EC Certificate for Class I sterile Stats, Certificate No. 41315937, MDD Requirements met for Class I and Class I sterile devices, CSA Requirements met (Master Contract # 213281), CSA Certificates issued, CB Scheme requirements met (CB Bulletin 112a), CB Test Certificates issued, CAN/CSA C22.2 No 601.1-M90, CAN/CSA C22.2 No. 60601-2-18-01, UL Std No 60601-1, IEC 60601-2-18, CE Mark EMC Directive, IEC 60601-1-2, CISPR 11, VCCI Technical V-3

Symbol Directory

The following international regulatory symbols are found on the GlideScope video laryngoscope and/or GlideScope video monitor and indicate compliance with international regulatory standards:

Symbol	Meaning
	Type BF equipment
	CE marking in accordance with the Medical Device Directive (CE ₀₄₁₃ for Sterile Devices)
	Canadian Standards Association (CSA) mark of certification to applicable standards for electro-medical equipment
	Tested to Federal Communications Commission Requirements
	Attention – consult accompanying documents. Read instructions before connecting or operating
	Subject to WEEE (Waste of Electronic Electrical Equipment) regulations

GLIDESCOPE[®] Video Laryngoscopes



GlideScope GVL[®] and Cobalt User's Manual



Corporate Headquarters:

Verathon Inc.

20001 North Creek Parkway,
Bothell, WA 98011 USA
800.331.2313 (Canada and US)
425.867.1348
Fax: 425.883.2896
verathon.com



Verathon Medical (Europe) B.V.

Linnaeusweg 11
3401 MS, IJsselstein
The Netherlands
+31.30.68.70.570
Fax: +31.30.68.70.512
verathon.eu



Manufacturer

Verathon Medical (Canada) ULC

2227 Douglas Road
Burnaby, BC V5C 5A9
Canada
604.439.3009
Fax: 604.439.3039

For additional contact information please visit verathon.com.

GlideScope, the GlideScope symbol, GlideRite, GVL, Verathon, and the Verathon Torch symbol are trademarks of Verathon Inc. All other brand and product names are trademarks of their respective owners.

The GlideScope® technology is covered under US Patents (6,655,377) (6,543,447) as well as European Patent 1307131. Additional patents pending.

Information in this User's Manual and Quick Reference Guide may change at any time without notice. For the most up-to-date information, see the online manuals on verathon.com.

GlideScope video laryngoscope systems are CE marked in accordance with the Medical Device Directive, and the Verathon Inc. quality system is Quality System Certified to ISO 13485:2003 standards.

© 2009–2011 Verathon Inc. No part of this manual may be copied or transmitted by any method without the express written consent of Verathon Inc.

Contents

Important Information	6
Product Description	6
Intended Use	6
Statement of Prescription.....	6
Intended Use.....	6
Notice to All Operators	7
Cautions.....	7
Introducing the GlideScope System.....	9
GlideScope System Components.....	10
GlideScope GVL® System.....	10
Cobalt Single-Use System	11
GlideScope System Setup Options	12
Displays, Controls, and Indicators	15
Monitor Back Panel	15
Monitor Front Panel	16
Monitor Front Panel LEDs.....	18
Getting Started.....	20
Initial Inspection	20
Preparing for First Use	21
1. Charging the Monitor Battery	21
2. Setting up the GlideScope System.....	24
Setting up the GlideScope System on the Mobile Stand.....	24
Setting up the GlideScope System in the hardshell case	29
Setting up the GlideScope System on an IV pole	31
3. Attaching and Detaching the GlideScope GVL or Cobalt Video Baton and GVL Stat.....	31
Attaching the GlideScope GVL to the Monitor.....	31
Selecting the Correct Video Baton and Stat.....	33
Attaching the Cobalt Video Baton to the Monitor	33
Inserting the Video Baton into the Stat.....	33
GlideScope Anti-Fog Feature	35

4. Connecting the Monitor to an External Video Device (Optional).....	36
5. Performing a Functional Check.....	37
Optional Accessory.....	38
GlideScope DVR for GVL®/Cobalt	38
Recording.....	38
Playback	39
Troubleshooting.....	39
Cleaning.....	40
Clinical Application Tips.....	41
The GlideScope 4-Step Technique.....	41
Tips for Working with Endotracheal Tubes.....	42
Cleaning, Disinfecting, and Maintaining the GlideScope GVL and Cobalt Systems.....	44
Cleaning, Disinfecting and Maintaining GlideScope GVL and Cobalt Systems.....	44
General Maintenance Information	44
General Cleaning and Disinfection Information.....	45
Table 1: Risk Assessment	45
Table 2: Chemical Compatibility and Disinfection Methods for GVL, Cobalt Video Batons and Video Cables ...	47
Table 3: Chemical Compatibility and Disinfection Methods for GlideRite® Rigid Stylet	48
Cleaning and Disinfecting the GlideScope GVL and Cobalt Systems.....	49
Cleaning the GlideScope GVL.....	49
Disinfecting the GlideScope GVL	50
Cleaning the GlideScope Cobalt Video Baton	50
Disinfecting the GlideScope Cobalt Video Baton	51
Cleaning the Video Cables	52
Cleaning the Monitor	52
Cleaning the Cradle.....	52
Cleaning and Disinfecting the GlideRite® Rigid Stylet..	53
Replacing the Monitor Battery	53
O-Ring Replacement	54
Transportation and Storage.....	55

Device Disposal	55
Warranty Offerings	56
Original First Year Total Customer Care Warranty	56
What is Covered	57
Premium Customer Care Warranty	57
Disclaimer of Additional Warranties	57
Contact Information	58
Parts and Accessories	59
Specifications	61
General Specifications.....	61
Operating and Storage Conditions	61
GlideScope System Components.....	63
Standards and Approvals	66
Symbol Directory	67

Important Information

Product Description

The GlideScope video laryngoscope system incorporates a miniature, high-resolution color camera, an LED light source, a rechargeable lithium battery, and NTSC video output for remote display or video recording.

The GlideScope video laryngoscope system is useful for anterior airways, neonatal intubations, obese patients, and patients with limited neck extension. Additionally, it is useful for teaching purposes, verification of endotracheal (ET) position, nasal intubation, and ET exchange.

The system is recommended for use with an endotracheal tube stylet, particularly the GlideRite® Rigid Stylet.

Intended Use

Statement of Prescription

Federal (USA) law restricts this device for sale by or on the order of a physician.

The GlideScope video laryngoscope system should be used only by individuals who have been trained and authorized by a physician or by health care providers who have been trained and authorized by the institution providing patient care.

Intended Use

GlideScope video laryngoscopes are intended for use by qualified medical professionals to obtain a clear, unobstructed view of the vocal cords for medical procedures.

Notice to All Operators

All operators should read this entire User's Manual prior to using the GlideScope system. Failure to follow these instructions may result in patient injury, compromise the performance of the system, and may void the system warranty.

Verathon recommends that new GlideScope users:

- ◆ Practice using the GVL® or Cobalt on a mannequin before clinical use
- ◆ Acquire clinical experience on patients without airway abnormalities

Refer to page 41 for recommended techniques.

Cautions



Caution. Risk of permanent equipment damage. Do not expose GlideScope video laryngoscopes or Cobalt video batons to temperatures above 140° F (60° C).

Do not disinfect GlideScope video laryngoscopes or Cobalt video batons using devices such as autoclaves, ultrasonic cleaners, or pasteurizers. Use of such methods to disinfect GlideScope video laryngoscopes or Cobalt video batons will cause permanent device damage and void the warranty. Refer to page 47 for a list of approved cleaning procedures and products.



MDD Class 1 Equipment Caution: Electrical shock hazard. Refer servicing to qualified personnel.

This equipment has been tested and found to comply with the standards listed in the Approvals section of this manual (page 65). These limits are designed to provide reasonable protection against harmful interference in typical medical installations.

This equipment generates, uses, and can radiate radio frequency energy and if used properly is very unlikely to cause harmful interference to any other device(s) in the vicinity.

However, there is no guarantee that interference will not occur in a particular installation. Interference can be determined by turning the equipment on and off. If this equipment does cause interference with other devices, try to correct the interference by one or more of the following measures:

- ◆ Re-orient or relocate the receiving device
- ◆ Increase the separation between equipment
- ◆ Connect the equipment to an outlet on a circuit different from that to which the other device(s) is (are) connected
- ◆ Consult your Verathon Medical Customer Care representative

NOTE: GlideScope video laryngoscopes must be used with the supplied cables to maintain electromagnetic interference (EMI) within certified limits.

Users should be aware that portable and mobile equipment (cellular phones, etc.) may affect medical electrical equipment and take appropriate precautions during operation.

Introducing the GlideScope System

GlideScope video laryngoscopes are designed for “1st pass success.” They provide a consistently clear view of a patient’s airway, enabling quick intubation. GlideScope video laryngoscopes are clinically proven to achieve a Cormack-Lehane Grade I or II view 99% of the time.¹

These Glidescope models include an integrated, high-resolution, CMOS camera, LED light source, and a patented anti-fog mechanism. They connect directly to a color video monitor for real time viewing, video output, and recording. The GlideScope system is available in both, reusable GVL® and single-use Cobalt versions, in a comprehensive range of configurations and sizes, allowing clinicians to meet the requirements of patients ranging in size from preterm infants to morbidly obese adults.

The GlideScope video laryngoscope is an ideal tool for physicians and other healthcare professionals who need to effectively manage standard to difficult airways. The GlideScope system is easy to use, learn, and teach. It is ideal for Acute Care settings and emergency environments. It also integrates easily into standard ED, OR, ICU, and NICU applications.

GlideScope video laryngoscopes may be useful for the following procedures:

- ◆ First use intubations, replacing Direct Laryngoscopy (DL)
- ◆ Normal or restricted oropharyngeal views/visualization and assessment of the oropharynx
- ◆ Cormack-Lehane grades I - IV laryngeal views
- ◆ Trauma airways - excellent when dealing with blood and secretions in the airway
- ◆ Airway management in morbidly obese patients
- ◆ Preterm and neonatal intubations

nobilization

1. Cooper RM. Cardiothoracic Anesthesia, Respiration and Airway; Early clinical experience with a new video laryngoscope (GlideScope) in 728 patients. *Canadian Journal of Anesthesia*. 2005; 52: 2: 191–198.

- ◆ Reintubation in Intensive Care Unit (ICU) settings
- ◆ Supervision and documentation of the laryngoscopy
- ◆ Nasal tracheal intubation
- ◆ Insertion of transesophageal echocardiatic probes
- ◆ Laryngoscopic foreign body removal
- ◆ Awake intubation for difficult airway management
- ◆ Insertion of double lumen tubes
- ◆ Teaching the anatomy of the airway

GlideScope System Components

Two interchangeable video laryngoscope systems are available: the reusable GVL® and Cobalt single-use system.

Please refer to page 59 for a complete listing of GlideScope system components and part numbers.

GlideScope **Video Laryngoscope** System

The GlideScope system includes:

- ◆ The GlideScope video monitor
- ◆ One reusable GVL®. The GVL is composed of a medical-grade plastic shell that houses a high-resolution CMOS camera, LED light source, and patented anti-fogging mechanism. The GVL device is available in four sizes. Additional units may be purchased separately.
- ◆ Video cable (connects the GVL to the monitor)
- ◆ GlideRite® Rigid Stylet

Figure 1. GlideScope video laryngoscope system components.



Cobalt Single-Use System

The Cobalt single-use system includes:

- ◆ The GlideScope video monitor
- ◆ Reusable video baton with integrated video cable. The Cobalt video baton includes a high-resolution CMOS camera, LED light source, and a patented anti-fogging mechanism. The Cobalt video baton is available in two sizes and each baton supports two sizes of GVL Stats.
- ◆ GVL Stats (sterile, single-use blades based on the current GlideScope GVL design) - five sizes are available
- ◆ One GlideRite Rigid Stylet

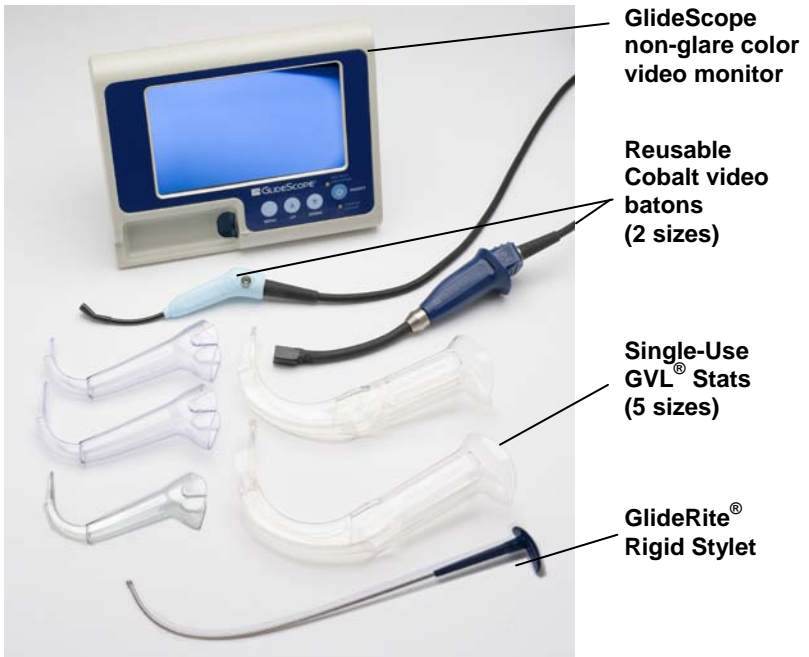
Figure 2. Cobalt single-use system.

GlideScope System Setup Options

The GlideScope video monitor, video laryngoscopes, and related accessories may be set up in various configurations in order to best meet the needs of your facility. The GlideScope System may be:

- ◆ Mounted on a mobile stand (Figure 3)
- ◆ Secured in a hard shell case for remote or emergency applications (Figure 4)
- ◆ Mounted on an IV pole (user-supplied) for use in clinics and hospitals (Figure 5)

Figure 3. GlideScope system on mobile stand.

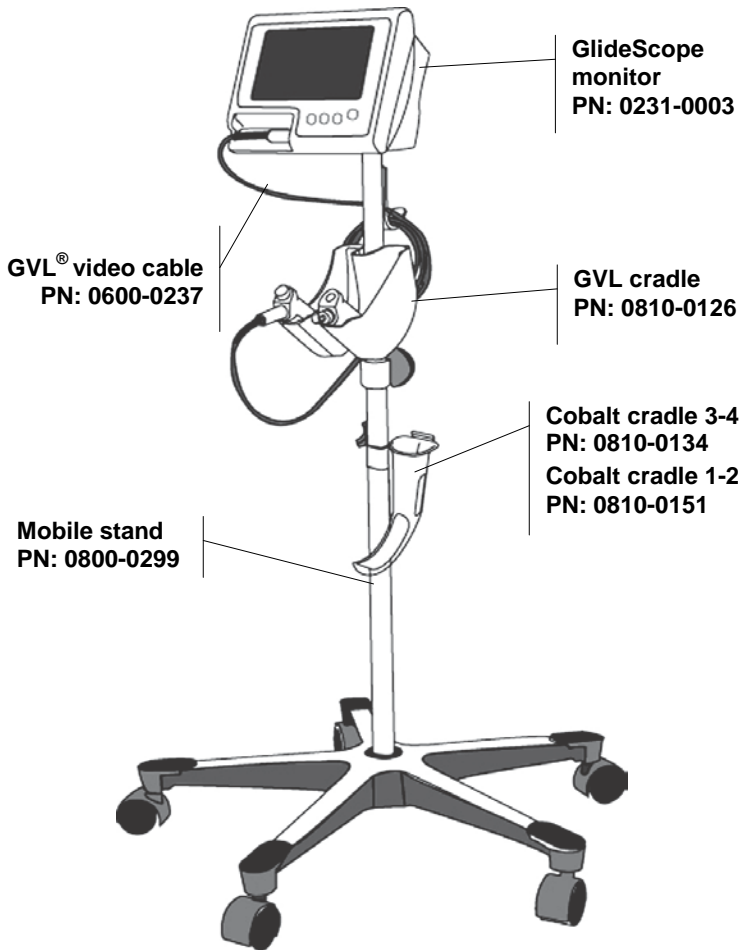

Figure 4. GlideScope system in hard shell case.

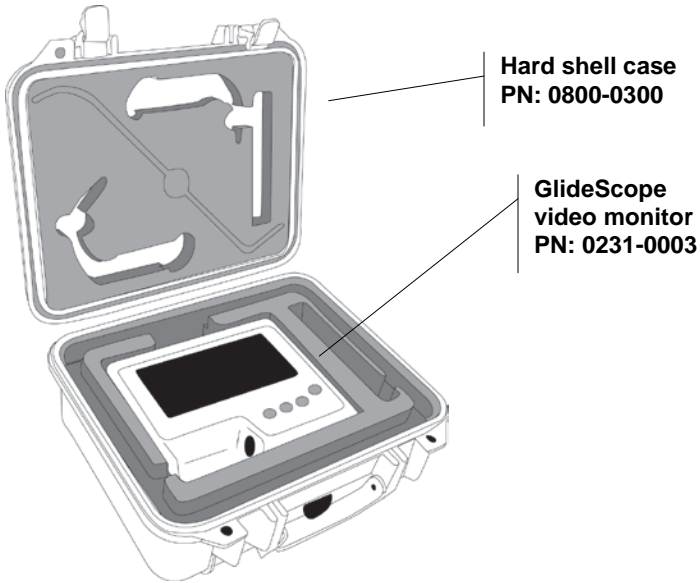
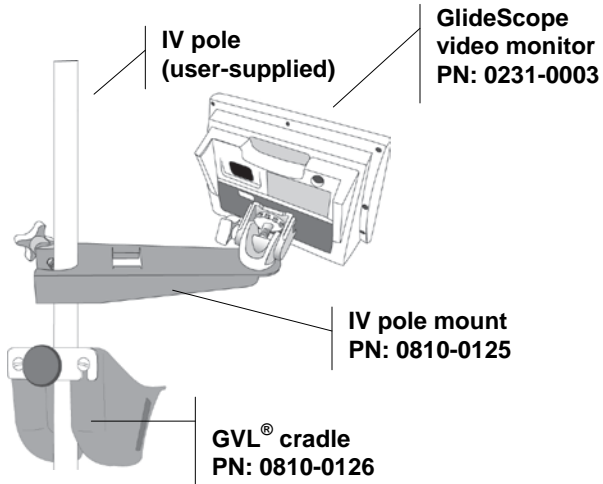

Figure 5. GlideScope system on IV pole (user-supplied).



Displays, Controls, and Indicators

Monitor Back Panel

The GlideScope video monitor back panel (Figure 6) contains the power cord connector, accessory video output connector, battery ON/OFF slider switch, and a mounting point for the optional mobile stand, IV pole, or hard shell case. Figure 6. GlideScope video monitor back panel.

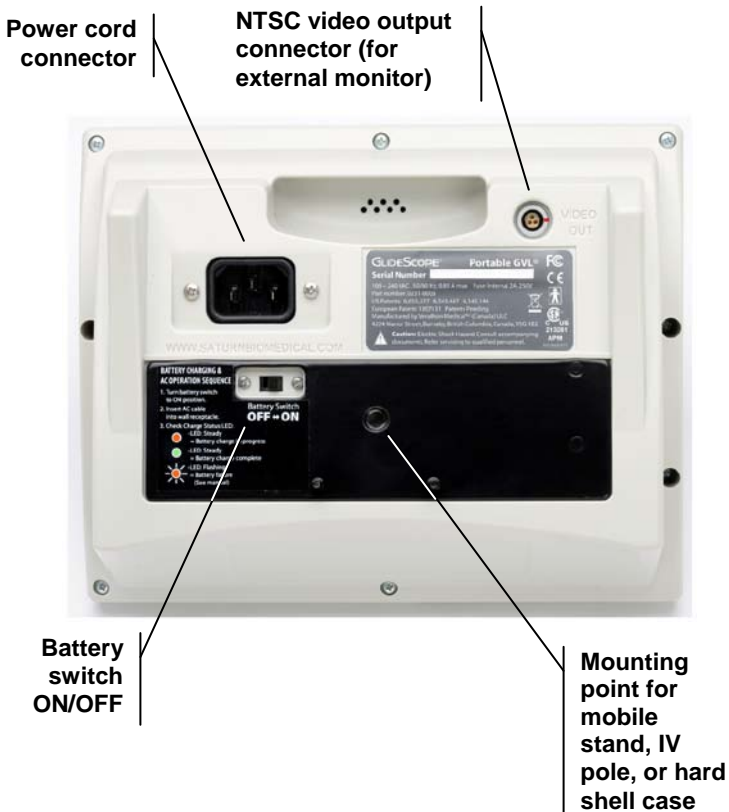



Monitor Front Panel

The GlideScope video monitor front panel (Figure 7) contains the video cable connector, two battery status LEDs, and four buttons: MENU, UP, DOWN, and ON/OFF. Button functions are described in the table below.

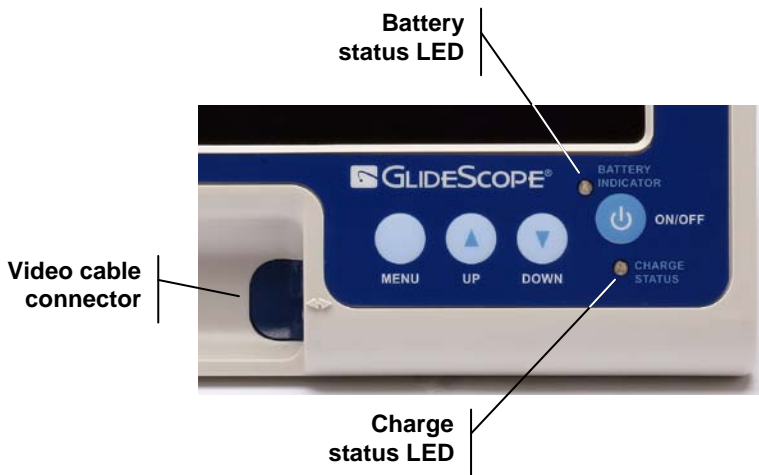
Figure 7. GlideScope video monitor front panel.



Monitor front panel buttons.

Button	Function
 ON/OFF	Press to turn the GlideScope System ON/OFF.
 UP DOWN	Press to increase/decrease monitor setting values.
 MENU	Press the MENU button repeatedly to make selections from the displayed list of options. A menu item is selected (active) when highlighted in yellow. Display settings include:

Brightness: When BRIGHTNESS is highlighted, press UP/DOWN to increase/decrease luminosity. A brightness setting of 18 - 20 units is recommended.

Contrast: When CONTRAST is highlighted, press UP/DOWN to increase/decrease image contrast. A contrast setting of 16 - 20 units is recommended.

Color: When COLOR is highlighted, press UP/DOWN to increase/decrease displayed color saturation. The default setting of 50 units (on a scale of 0 - 100 units) is recommended.

Mirror: Press UP to display a mirror image of the displayed image. Press DOWN to return to the original view.

Reset: Pressing either UP or DOWN will return all monitor settings to the factory defaults.

Exit: When EXIT is highlighted, press either UP or DOWN to save all settings and return to the viewing screen.

Normal, NTSC, AV1: These three items display the format and channel of the signal that is being received from the GlideScope. Since these GlideScope cameras use the NTSC format, these settings will not change.

NOTE: VOLUME and MUTE may appear on some monitor screens. These features are currently inactive.

Monitor Front Panel LEDs

The monitor front panel has two status LEDs that indicate battery usage and charge states (Figure 8).

- ◆ The battery indicator LED illuminates when the monitor is operating on battery power
- ◆ The charge status LED indicates the battery charge level





Figure 8. Front panel LEDs indicate battery usage and charge status.



Battery Indicator LED States

Battery Indicator LED	Description
No LED	Monitor is off or the battery is completely depleted and needs to be recharged
Solid Green	Monitor is on and battery level is normal
Flashing Green	Flashing Green indicates two states of low battery: <ul style="list-style-type: none"> ● If there is no beeping, there are approximately five minutes left before the unit turns off due to low battery. ● If there is beeping, there is approximately one minute left before the unit turns off due to low battery.

Charge Status LED States

Charge Status LED	Description
No LED 	AC power is not connected
Flashing Orange 	Flashing Orange can indicate two states: <ul style="list-style-type: none"> ● If the AC power is connected, flashing orange could mean the battery switch is in off (to the left) position. In this case the monitor will still function but the battery will not be charged. ● If the AC power is not connected, flashing orange means the battery is malfunctioning. Please contact your Verathon Medical Customer Care representative.
Solid Green 	The battery is fully charged
Solid Orange 	Charging is in progress

Getting Started

Initial Inspection

Upon receipt, inspect the components of the GlideScope video laryngoscope system for any obvious physical damage that may have occurred during shipment. Verathon Medical recommends that the inspection be performed by a biomedical engineer or other qualified professional who is familiar with electronic medical devices.

The components you receive will vary depending on which configuration was ordered (see Figure 3-5). To verify that you have received the appropriate components, refer to the packing list included with your system.

If any of the components are missing or damaged, notify the carrier and Verathon Medical Customer Care immediately at:

- ◆ 800.331.2313 (Canada and US)
- ◆ 425.867.1348 (International)
- ◆ +31.30.68.70.570 (Europe)

Please refer to page 58 for additional contact information.

Preparing for First Use

Prior to using the GlideScope system for the first time, perform the following steps:

1. Charge the monitor battery (instructions begin on this page).
2. Set up the GlideScope system in your preferred configuration (instructions begin on page 24).
3. Attach a video laryngoscope to the monitor (instructions begin on page 34).
4. Connect the monitor to an external source such as a TV screen or NTSC video monitor (optional).
5. Perform a functional check (instructions begin on page 37).

1. Charging the Monitor Battery

The GlideScope system can operate on AC power (wall current) or battery power.

The GlideScope monitor contains a lithium battery that provides power to the GlideScope video laryngoscope. Under normal conditions, the battery will last approximately 90 minutes before it needs to be recharged.

IMPORTANT! The battery must be fully charged prior to first use.

For optimal battery life:

- ◆ The battery must be fully charged before first use in battery mode (takes approximately 3 hours).
- ◆ When the battery is low, the charge status LED (on the monitor front panel) will flash green for approximately five minutes.
- ◆ When the battery is nearly depleted, the charge status LED will flash green and beep. This indicates that the battery has approximately one minute of power remaining.
- ◆ The monitor battery should be charged at room temperature, between 0° - 40° C (32° - 104°F).

To charge the monitor battery:

IMPORTANT! Before beginning, make sure the AC power cord is disconnected and the battery switch (on the monitor rear panel) is in the OFF position (to the left).

1. Slide the battery switch to the ON position (to the right) (Figure 9).
2. Insert the female end of the power cord into the power cord connector on the back of the monitor (Figure 9).

Figure 9. Rear panel detail: AC power cord connector and battery switch in the ON position.

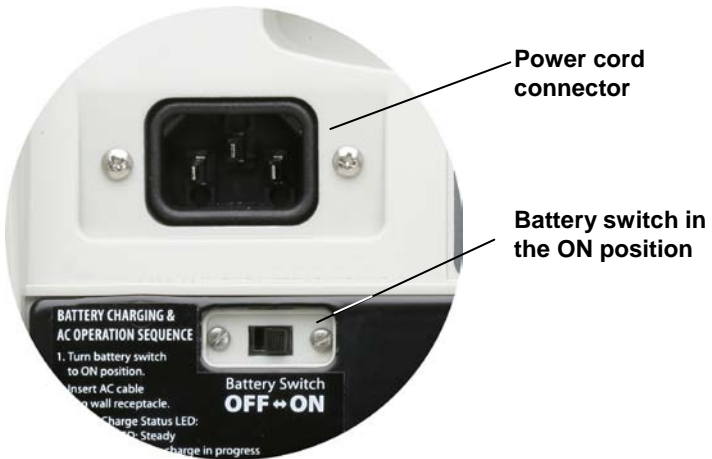

3. Insert the other end of the power cord into a wall outlet or appropriate AC power source.

NOTE: For power supply compatibility information, please refer to the label on the back of the monitor.

4. The charge status LED will turn orange, indicating that the charging cycle has begun. When the battery is fully charged, the charge status LED will turn green (Figure 10)

At this point the system is fully functional on battery power.

Figure 10. The charge status LED will turn green when the battery is fully charged.



NOTE: For more information about charge status LED states, refer to table on page 19.

2. Setting up the GlideScope System

The GlideScope system may be set up in one of three configurations:

- ◆ On a mobile stand (Figure 3)
- ◆ In a hard shell case (Figure 4)
- ◆ On an IV pole (Figure 5)

Setting up the GlideScope System on the Mobile Stand

(Refer to Figure 3, page 13)

Attaching the center pole to the base (mobile stand only)

1. Remove the hex bolt and washers from the bottom of the pole.
2. Insert the bottom end of the pole into the top of the base.
3. Flip the base over and screw the bolt and washers back into place to secure the pole to the base. To keep the center pole stable, be sure to tighten the bolt securely.

Figure 11. Attaching the mobile stand base to the center pole hardware stack-up.

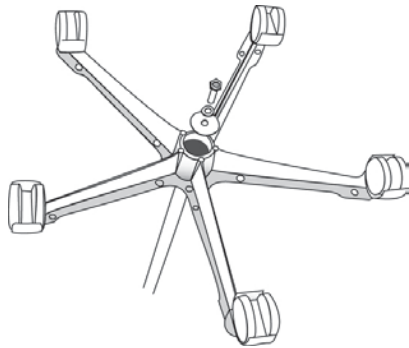
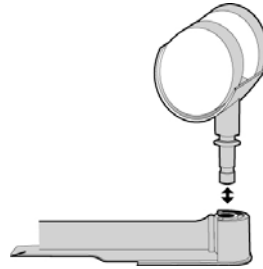

Figure 12. Removing and inserting the wheels from the mobile stand.

4. To reinsert the mobile stand wheels: insert the wheel pin into the opening on the end of the mobile stand base (Figure 12). Applying steady, moderate force, press the wheel pin into the base until it snaps into place.



To remove the mobile stand wheels

The mobile stand wheels may be removed to facilitate storage and transportation.

Using steady, moderate force, pull the wheels away from the base.

Adjusting the height of the mobile stand (Figure 13)

1. Loosen the black height adjustment knob located on the mobile stand pole by turning it counterclockwise.
2. Raise or lower the pole to the desired height.
3. Secure the pole in position by turning the height adjustment knob clockwise.

Figure 13. Adjusting the height of the mobile stand.



Attaching the monitor to the mobile stand

Hold the monitor against the screw on the tilt head and turn the tilt head fastener clockwise to tighten (Figure 14).

Adjusting the monitor angle

Before use, the angle of the monitor should be adjusted for optimal viewing. The ideal angle will be determined by the working position of the monitor and the user.

To adjust the angle of the monitor:

1. Loosen the angle adjustment knob located on the tilt head of the IV pole mount by turning it counterclockwise.
2. Tilt the monitor to the desired angle.
3. Secure the monitor in place by turning the angle adjustment knob clockwise (Figure 14).

Figure 14. Attaching the monitor to the mobile stand.

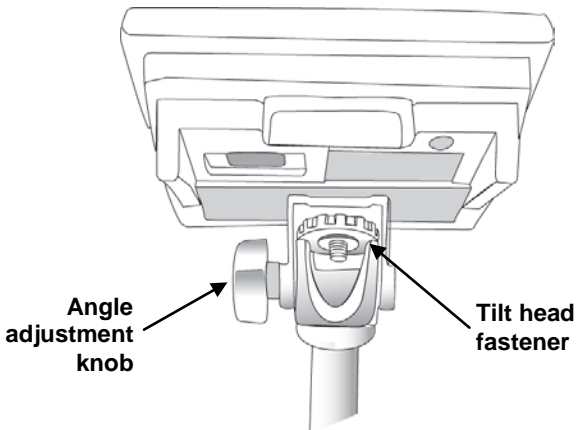

Attaching the GVL cradle

To attach the GVL® cradle:

1. Open the cradle latch and position the mobile stand pole on the back of the cradle.
2. Close the cradle latch and tighten in place by turning the black cradle adjustment knob clockwise (Figure 15).

Figure 15. Attaching the GVL cradle to the mobile stand.

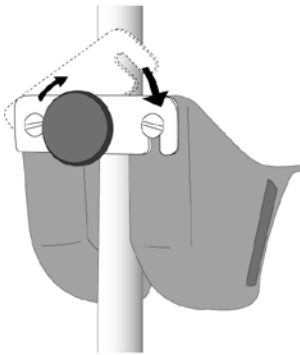
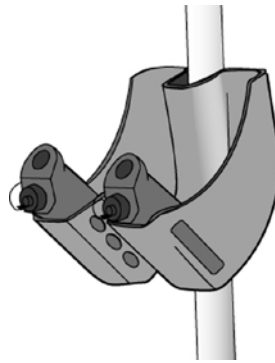

Figure 16. GlideScope GVLs in the cradle bays.



Attaching the Cobalt Video Baton Cradle

The Cobalt video baton cradle may be mounted either to the GVL® cradle or directly to the mobile stand center pole.

To attach the Cobalt video baton cradle to the GVL cradle:

1. Attach the GVL cradle to the mobile stand as shown in Figure 15.
2. Hook the Cobalt cradle into the GVL cradle as shown in Figure 16.

Figure 17. Attaching the Cobalt video baton cradle to the GVL cradle.

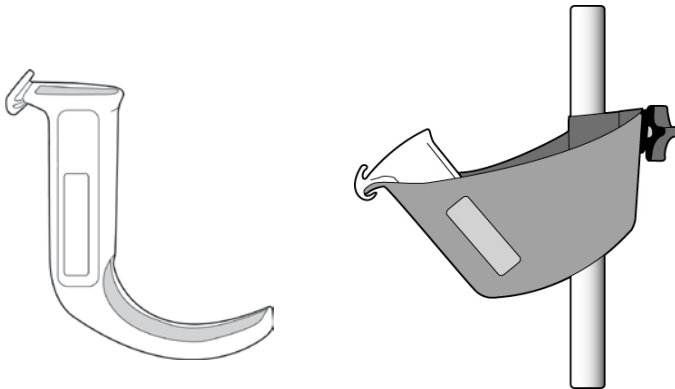

To attach the Cobalt video baton cradle directly to the mobile stand or IV pole:

1. Attach the center pole clamp to the Cobalt cradle.
2. Attach the center pole clamp and Cobalt video baton cradle to the mobile stand or IV pole and turn the black knob clockwise to tighten.

Figure 18. Attaching the center pole clamp to the Cobalt cradle.

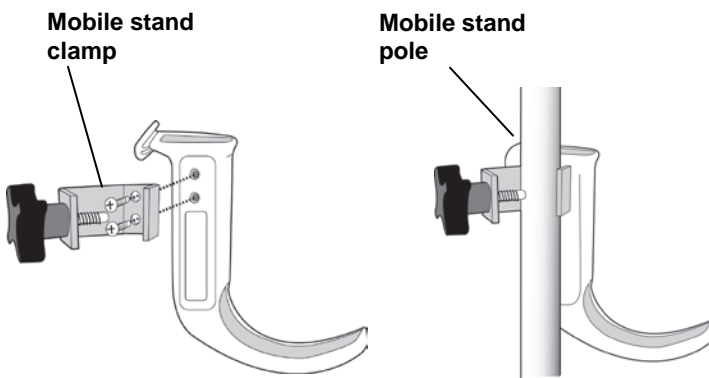

Setting up the GlideScope System in the hard shell case

Refer to Figure 19 on page 30.

The hard shell case comes with a custom foam insert designed to protect the GlideScope system components. To secure the monitor in the hard shell case:

1. Remove the foam insert from the bottom of the hard shell case.
2. Remove the screw from the foam insert.
3. Align the foam insert with the monitor rear panel so that the battery switch remains accessible.
4. Screw the foam insert to the monitor until the screw is snug (Figure 19). Do not over-tighten the screw.

Figure 19. Removing the video monitor from the hard shell case.

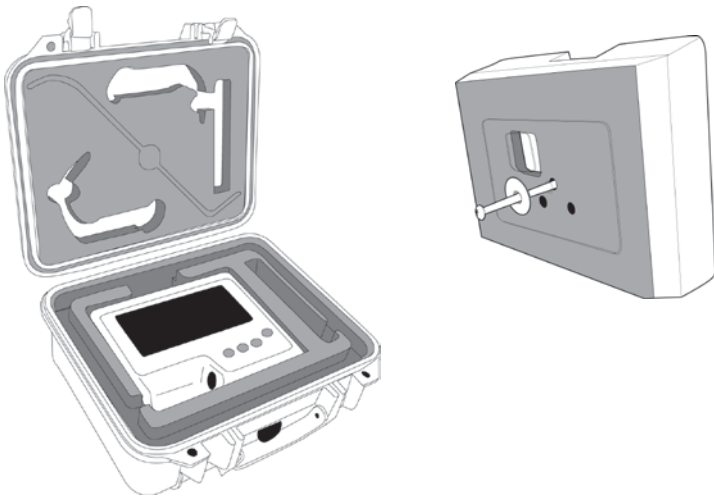

Removing the video monitor from the hard shell case

To remove the monitor from the hard shell case:

1. Grasp the monitor handle and pull the monitor and foam out of the hard shell case.

-
2. On the back of the foam insert, remove the screw holding the monitor to the foam.

Setting up the GlideScope System on an IV pole

Refer to Figure 5, page 14.

1. Attach the IV pole mounting bracket to the IV pole by tightening the bracket attachment knob until the bracket is secure.
2. To attach the GlideScope video monitor: hold the monitor against the screw on the tilt head and turn the tilt head fastener clockwise to tighten (Figure 14).

Figure 20. Attaching the mounting bracket to the IV pole.

Bracket attachment knob

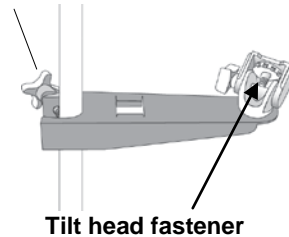

3. To attach a GVL® cradle to the IV pole, refer to (Figure 15).

To attach a Cobalt video baton cradle to the IV pole refer to Figure 17 and Figure 18.

3. Attaching and Detaching the GlideScope GVL or Cobalt Video Baton and GVL Stat

Attaching the GlideScope GVL to the Monitor

The GlideScope GVL® connects to the monitor with a detachable video cable (supplied).

1. Insert the GVL video cable into the connector port located on the face of the monitor so that the arrows on the cable and the monitor are aligned (Figure 21).

NOTE: When connecting and disconnecting the cable, grasp the connector by the gray sleeve.

Figure 21. Attaching the GVL video cable to the monitor.

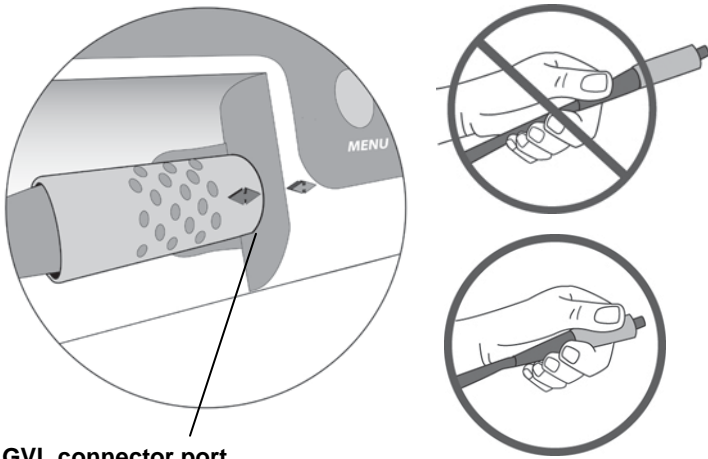

GVL connector port

2. Insert the other end of the cable into the port located on the handle of the GVL (Figure 22).

Figure 22. Attaching the video cable to the monitor and GVL.

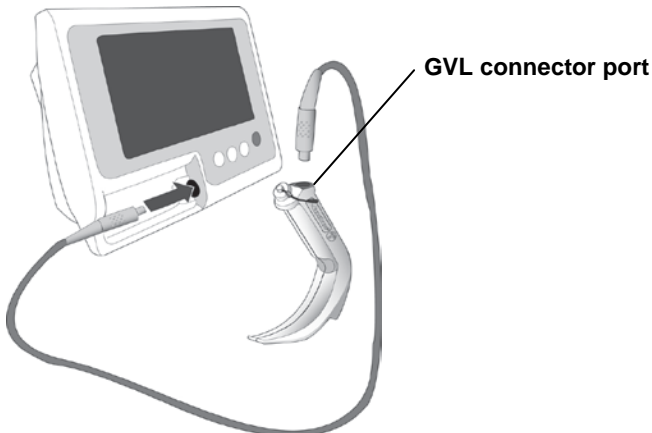

NOTE: Visually inspect the GVL® to assure that all surfaces are free of unintended rough areas, sharp edges, protrusions, or cracks.

Selecting the Correct Video Baton and Stat

Make sure that you select the Cobalt video baton and GVL Stat that best fit your patient. Verathon® recommends the following:

- ◆ Cobalt video baton 1-2 (for use on infants)
 - GVL 0 Stat (patients less than 1.5 kg)*
 - GVL 1 Stat (patients between 1.5-3.6 kg)*
 - GVL 2 Stat (patients between 1.8-10 kg)*
- ◆ Cobalt video baton 3-4 (for use on children and adults)
 - GVL 3 Stat (patients between 10 kg-Adult)*
 - GVL 4 Stat (patients between 40 kg-Morbidly obese)*

* Weight ranges are approximate; a medical professional must evaluate on a patient-by-patient basis.

Figure 23. Cobalt video batons and Stats.



Attaching the Cobalt Video Baton to the Monitor

The Cobalt video baton includes an integrated video cable. To attach it to the monitor, insert the video cable connector into the port located on the face of the monitor so that the arrows on the cable and the monitor are aligned as shown in Figure 21.

NOTE: When connecting and disconnecting the connector cable, grasp the cable by the gray sleeve (Figure 21).

Inserting the Video Baton into the Stat

1. Before you use the GVL® Stat, visually inspect the Stat to ensure that all exterior surfaces are free of unintended rough areas, sharp edges, protrusions, or cracks.

-
2. Before you slide the baton into the Stat, make sure that the logo on the side of the baton and the logo on the side of the Stat are aligned.
3. Slide the video baton into the GVL Stat until it clicks into place.

Note: Make sure that you do not insert the video baton backward.

Figure 24. Insert the video baton cable into the Stat.



Figure 25. Do not insert the video baton cable into the Stat backward.



Removing the Video Baton from the Stat

The GVL® Stat is a sterile, single-use device. After each use, it should be removed from the Cobalt video baton and disposed of properly. To Remove the Cobalt video baton from the GVL Stat:

1. Hold the Stat in one hand.
2. With the other hand, grasp the handle of the video baton and pull firmly (figure 26).
3. To reduce the force required to remove the baton from the Stat, use your thumb and finger to gently press the Stat (figure 26).

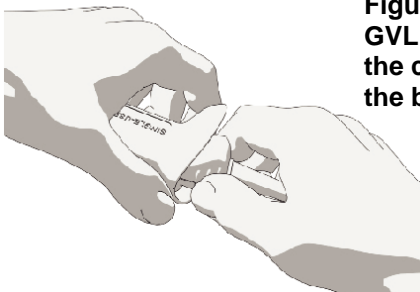

Figure 26. When using the GVL Stat, gently pressing the collar makes removing the baton easier.

GlideScope Anti-Fog Feature

To ensure optimal results of the anti-fog heating feature on the GlideScope video laryngoscope, perform the following steps:

Single-Use Model

If using the GlideScope Cobalt model, follow steps 1, 2, and 3 recommended below.

Reusable Models

If using the GlideScope GVL® model, attach the GVL to the system then follow steps 2 and 3.

1. Prior to use, open the GVL Stat pouch, but do not remove the Stat from the packaging (to keep the Stat clean until ready for use). With the Stat still in the package, insert the Cobalt video baton into the Stat. The video baton must be securely seated in the GVL Stat for efficient heating of the Stat.
2. Turn on the GlideScope monitor to activate the anti-fog heating feature.
3. After 30 seconds to 120 seconds, the anti-fog feature should be fully effective, depending on the ambient temperature and humidity where the equipment is being stored and/or used.

If the GlideScope GVL, video baton or Stat are stored in cold conditions, additional warming time may be required for optimal performance of the anti-fog feature.

4. Connecting the Monitor to an External Video Device (Optional)

The monitor may be connected to an NTSC-compatible external device such as a TV screen or video recorder by using an optional Verathon® video output cable. Please contact your Verathon Medical Customer Care Representative for more information.

To connect the monitor to an external video device:

1. Insert the video output cable into the port on the back of the video monitor.
2. Connect the opposite end of the cable to the external viewing device.

Figure 27. Attaching a video output cable to the monitor.

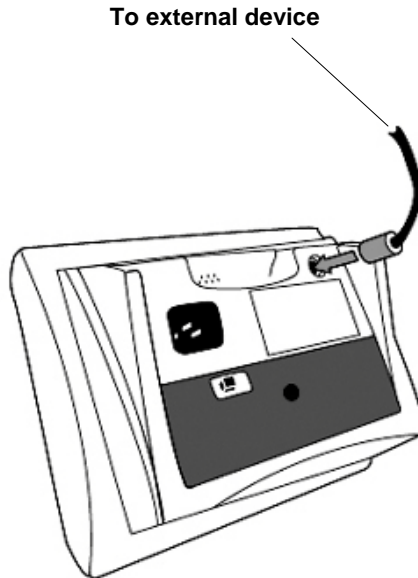

5. Performing a Functional Check

Prior to first use, perform the following functional check to assure that the GlideScope system is working properly. Please contact your Verathon Medical Customer Care Representative if your GlideScope system does not function as described below.

To perform a functional check of the GlideScope system:

1. Fully charge the monitor battery (see page 21).
2. Connect a GlideScope video laryngoscope to the monitor (GVL® or Cobalt video baton + GVL Stat, see page 32).
3. Slide the battery switch on the back of the monitor to the ON (to the right) position.
4. Turn the system on by pressing the ON/OFF button located on the face of the monitor.
5. Observe the monitor screen to verify that an image is being received from the GlideScope (Figure 28).

NOTE: The upper left corner of the LCD screen may display a small portion of the GVL blade (Figure 28). The blade is captured in the view due to the wide-angle properties of the camera lens. This opaque portion acts as a frame of reference during the intubation process and assures that the orientation of the image is correct in the monitor.

Figure 28. When the power is on, one corner of the GVL® blade is visible in the display.

Portion of GlideScope blade (frame of reference)

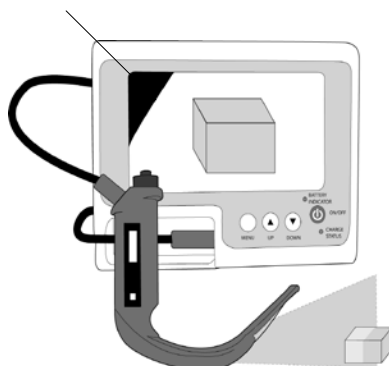

Optional Accessory

GlideScope DVR for GVL/Cobalt

The GlideScope DVR (Digital Video Recorder) is designed to record intubations performed with the GlideScope GVL/Cobalt.

INSTRUCTIONS FOR USE

Recording

1. Ensure monitor is OFF and SD card no larger than 2GB is inserted into the DVR.
2. Connect GVL/video baton cable to DVR

Figure 29. GlideScope DVR



3. Connect DVR cable to monitor
4. Turn monitor ON
5. REC LED will light up in solid RED after approximately 3 seconds
6. DVR begins recording automatically

Playback

1. Turn the monitor OFF and wait until REC LED turns OFF (approximately 3 seconds)
2. Open DVR door and remove SD card by pushing and releasing.
3. Insert the SD card in an SD card reader connected to a PC
4. Browse to the DVMPG4 folder in SD card drive
5. Playback any recordings with .ASF extensions



Troubleshooting

If REC LED is blinking, there may be a problem with recording. Possible causes:

1. Connections are not secure. Verify cable connections:
 - GVL®/video baton to DVR
 - DVR to monitor
2. SD card is missing or not inserted properly. Turn monitor OFF; ensure SD card is properly inserted and try again.
3. SD card is defective. Try another SD Card.
4. Problem with GVL/video baton. Ensure proper function by connecting GVL/video baton directly to monitor.

If the problem persists, contact Verathon Medical Customer Care.

Cleaning

Clean the exterior of the DVR with IPA (70% Isopropyl Alcohol Solution) wipes.

Clinical Application Tips

The GlideScope 4-Step Technique

Verathon® recommends using the GlideScope 4-Step Technique as outlined below:

- 1. In the Mouth:** looking directly into the patient's mouth and with the GlideScope GVL® in the left hand, introduce the GlideScope video laryngoscope into the midline of the oral pharynx.
- 2. At the Screen:** With the laryngoscope inserted, look at the monitor to identify the epiglottis, then manipulate the scope to obtain the best glottic view.
- 3. In the Mouth:** looking directly into the patient's mouth, not at the screen, carefully guide the distal tip of the tube into position near the tip of the laryngoscope.
- 4. At the Screen:** Look to the monitor to complete the intubation; gently rotate or angle the tube to redirect as needed.

Tips for GlideScope Video Laryngoscope Insertion

The GlideScope GVL® is designed to be inserted down the midline of the tongue to the epiglottis.

The GlideScope GVL may be used to produce a Macintosh indirect lift of the epiglottis, or a Miller lift.

Intubations using the GlideScope GVL only require approximately 0.5 - 1.5 kg of lifting force.

The use of an endotracheal tube stylet is recommended. The GlideRite® Rigid Stylet has been designed to complement the angle of the GVL to facilitate intubation, and should be used with endotracheal tubes 6.0mm and larger. A malleable stylet may be used with a 60° - 90° angle.

To aid the passage of the endotracheal tube when at the vocal cords, gradually withdraw the stylet approximately 5 cm. A 1cm adjustment (withdrawal) of the laryngoscope may be beneficial to reduce the viewing angle and allow the glottis to drop.

Figure 30. The curvature of the GlideRite Rigid Stylet complements that of the GVL and GVL Stat.



Tips for Working with Endotracheal Tubes

- Insert the ET tube behind or immediately adjacent to the GVL® Stat.
- Do not insert the stylet into the larynx during intubation.

- You can bend the proximal tip of the stylet backward to permit one-handed operation of the ET tube.
- Carefully introduce the distal end of the ET tube between the vocal folds.
- When introducing the GlideScope and/or the endotracheal tube, look directly into the mouth to avoid damaging the endotracheal tube cuff, the patient's teeth, or the soft tissues such as the soft palate or tonsils.
- Advance the ET tube while simultaneously withdrawing the stylet with the thumb (Figure 31). The stylet should be withdrawn approximately 5 cm.
- Avoid excessive lifting or pushing of the glottis by the GVL Stat. Maximum laryngeal exposure may not facilitate intubation; reducing the elevation applied to the laryngoscope may make inserting the ET tube easier.

Figure 31. The GlideRite Rigid Stylet is designed for one-handed removal from the endotracheal tube.



Cleaning, Disinfecting, and Maintenance

Cleaning the GlideScope GVL® and Cobalt system is an important part of maintaining the system. Make sure that the system is clean before each use. You should also examine the system periodically to make sure it is operating correctly.

General Maintenance Information

Periodic inspections should be performed to ensure safe and effective operation. It is recommended that a qualified technician perform a full visual inspection of all components at least every three months.

The technician should check for the following items:

- ◆ External damage
- ◆ Damage to the power supply
- ◆ Connectors and cable insulation integrity

To ensure patient safety, users should perform a routine inspection of the GlideScope video laryngoscope before every use to ensure that all endoscopic components are free of unintended rough surfaces, sharp edges, protrusions, or cracks.

If inspection reveals any faults in the components, contact Verathon Medical Customer Care. All repairs must be performed by an authorized Verathon Medical Service Center.



Caution. Risk of permanent equipment damage.
Do not expose GlideScope video laryngoscopes or Cobalt video batons to temperatures above 140° F (60°C). Do not disinfect GlideScope video laryngoscopes or Cobalt video batons using devices such as autoclaves, ultrasonic cleaners, or pasteurizers. Use of such methods will cause permanent device damage and void the warranty. Refer to cleaning section for a list of approved cleaning procedures and chemicals.

General Cleaning and Disinfection Information

Table 1: Risk Assessment

Device	Sterile	Use	Spaulding's CDC Classification	Disinfection			Sterilization
				Low Level	Int. Level	High Level	
GVL®	Non-sterile	Reusable	Semicritical			X	
GVL Stat	Sterile	Single use	Semicritical				
Cobalt video baton	Non-sterile	Reusable	Noncritical	X			
Video cables	Non-sterile	Reusable	Noncritical	X			
Stylet	Non-sterile	Reusable	Semicritical			X	
Monitor [#]	Non-sterile	Reusable	Noncritical	X			
Cradle [#]	Non-sterile	Reusable	Noncritical	X			

It is understood that all items in this chart will be used as intended.

Key:

- * The Cobalt video baton is a nonsterile, reusable device which is protected from contact with mucous membranes and nonintact skin by the Stat (sterile, single-use) when used as intended. Low Level Disinfection is recommended for the Cobalt video baton after every patient use. High Level Disinfection is required for the video baton when it is visibly soiled.
- # Disinfect monitor and cradle when they are visibly soiled and on a regular basis as per a schedule established by the medical care facility or provider.
- Shaded areas - not required/not compatible with device materials.
- Checked boxes (x) show minimum requirement.
- Unshaded areas show permissible levels of disinfection based on compatibility with device materials.

Warning: Disinfectants and cleaning methods listed are recommended by Verathon® based on compatibility with product materials. Refer to the label instructions for guidance on disinfection efficacy and appropriate clinical uses.

Caution: Meticulous cleaning must precede any disinfection process, to ensure all foreign matter is removed from the surface of the device. This allows the active ingredients of the chosen process to reach all the surfaces of the device.

Availability of cleaning products varies by country, and we are unable to test products in every market. Please use the list of recommended chemicals in this manual to compare with products available locally.

Note: When using any of the chemicals listed below, read and comply with product use instructions in all applications.

Table 2: Chemical Compatibility and Disinfection Methods for GVL®, Cobalt Video Batons, and Video Cables

Active Ingredient	Compatibility	Conditions	Disinfection Level	Caution/ Comments
Enzymatic debridement agent/ detergent	General hospital grade	As per instructions	N/A	Surface cleaning only in preparation for disinfectant
Isopropyl Alcohol Solution	70%	70% used to wipe down with minimum 1 minute exposure	Low	
Hydrogen Peroxide	Up to 7.5%	7.5% – exposure for 30 minutes at $\geq 20^{\circ}\text{C}$ or as per manufacturer's instructions	High	
Vaporized Hydrogen Peroxide	90%	90% / 42 min	See comments on right	Compatibility has been established in vaporized hydrogen peroxide sterilization systems for ease of use
Glutaraldehyde	Up to 3.4%	2.0% – exposure for minimum 20 minutes at 20°C or as per manufacturer's instructions	High	
Ortho-Phthalaldehyde	0.55%	0.55% – exposure for 12 minutes at 20°C or as per manufacturer's instructions	High	
Peracetic Acid	0.2%	0.2% – exposure for minimum 12 minutes at 50 to 56°C or as per manufacturer's instructions	See comments on right	Classified as a chemical sterilant
Bleach (Sodium Hypochlorite)	Up to 8000ppm	5000ppm – exposure for 10 minutes at 20°C	High	Corrosive for connector pins and SS ring
		500ppm – used to wipe down with minimum 1 minute exposure	Low	Noncorrosive at $\leq 500\text{ppm}$

Refer to pages 49-52 for disinfecting steps.

Table 3: Chemical Compatibility and Disinfection Methods for GlideRite® Rigid Stylet

Active Ingredient	Compatibility	Conditions	Disinfection Level	Caution/ Comments
Glutaraldehyde	Up to 3.4%	2.0% – exposure for minimum 20 minutes at 20°C or as per manufacturer's instructions	High	
Ortho-Phthalaldehyde	0.55%	0.55% – exposure for 12 minutes at 20°C or as per manufacturer's instructions	High	
Peracetic Acid	0.2%	0.2% – exposure for minimum 12 minutes at 50 to 56°C or as per manufacturer's instructions	See comments on right	Classified as a chemical sterilant
Isopropyl Alcohol Solution	70%	70% – exposure for 10 minutes at 20°C	Intermediate	
		70% used to wipe down with minimum 1 minute exposure	Low	
Bleach (Sodium Hypochlorite)	≤ 500ppm	500ppm – used to wipe down with minimum 1 minute exposure	Low	Noncorrosive at ≤ 500ppm
Enzymatic debridement agent/ detergent	General hospital grade	As per instructions	N/A	Surface cleaning only in preparation for disinfectant
N/A	Tested in autoclave (steam cycle)	Minimum 4 minute 132°C pre-vacuum steam sterilization cycle	See comments on right	Based on requests from users, an autoclave cycle has been established for the stylet for ease of use

Refer to page 53 for cleaning & disinfecting steps.

Cleaning and Disinfecting the GlideScope GVL and Cobalt Systems

Warning

Make sure that you do not overheat the GlideScope GVL® or Cobalt video baton during cleaning.

Caution. Risk of permanent equipment damage.

Do not expose GlideScope GVL or Cobalt video batons to temperatures above 140° F (60°C). The manufacturer's warranty is void if the product is exposed to temperatures above 60°C (140°F).

Caution

Do not use autoclaves or pasteurizers for the GlideScope GVL and Cobalt systems.

Use of such methods will cause permanent device damage and void the warranty.

Bleach can be used on the baton but with special attention to the connector. Bleach may corrode the stainless steel inserts and damage the connector pins.

Note: GlideScope GVL and Cobalt video baton laryngoscopes designed to better withstand vaporized hydrogen peroxide are identified by the metal label.



Cleaning the GlideScope GVL

The GlideScope GVL is a nonsterile reusable device. It is required that the GlideScope GVL is cleaned and disinfected after every patient use, using a High Level Disinfectant method as defined in Table 2.

To clean the GlideScope GVL®:

1. Disconnect the GVL from the video cable.
2. Insert the attached protective cap into the video cable port to protect the electronic connector.
3. Wash the GVL manually using a hospital grade equipment detergent or an enzymatic debridement agent/detergent to remove all foreign material (e.g., soil and organic material) from the surface of the device.

Disinfecting the GlideScope GVL

To disinfect, use any of the chemicals listed in Table 2 and do the following:

1. Ensure the equipment is clean (see Cleaning Section for GVL).
2. Ensure the protective cap on the connector is secure.
3. Prepare the disinfectant solution at the concentration and temperature recommended by the disinfectant manufacturer. Disinfect the equipment following the disinfectant manufacturer's instructions or as stated in Table 2.
4. After the disinfection process, rinse (as applicable) and dry the GVL and then store the equipment in a clean environment.

Cleaning the GlideScope Cobalt Video Baton

The GlideScope Cobalt video baton is a nonsterile reusable device, which is protected by the GVL Stat and is not intended to have direct patient contact.

Caution

Do not place the Cobalt video baton in the cradle if it is contaminated.

The video baton, which is protected from direct contact with the patient by the Stat, will normally only require cleaning and wiping down between uses using either IPA or bleach. If there is concern about its level of contamination, or if it is exposed to contamination, then it can be disinfecting using a high level disinfection method, as defined in Table 2 on page 47.

Caution: Ensure the protective cap is properly fitted on the video baton prior to immersion in water. Bleach can be used on the video baton but with special attention to the connector, as it may corrode the stainless steel inserts and damage the connector pins. You can also use a soft brush to scrub the video baton, taking care not to damage the camera lens. However, do not use a wire brush because it may damage the surface of the video baton.

1. Detach the GVL® Stat from the video baton as described on page 35.

Note: A used GVL Stat is a biohazard and must be disposed of in a manner consistent with local protocols.

2. Disconnect the video baton from the monitor.
3. Place the protective cleaning cap over the connector (Figure 32).

Figure 32. Make sure that the protective cap is in the correct position before you clean the video baton.



Correct cleaning position – protective cap covering the electronic connector

4. Wash the baton manually using a hospital grade equipment detergent or an enzymatic debridement agent/detergent to remove all foreign material (e.g., soil and organic material) from the surface of the device.
5. The Cobalt video baton can now be disinfected. Disinfecting the GlideScope Cobalt Video Baton.

To disinfect, use any of the chemicals listed in Table 2 and do the following:

1. Ensure the equipment is clean (see Cleaning Section for Cobalt video baton).
2. Ensure the protective caps on the connectors are secure.
3. Prepare the disinfectant solution at the concentration and temperature recommended by the disinfectant manufacturer. Disinfect the equipment following the disinfectant manufacturer's instructions or as stated in Table 2.
4. After the disinfection process, rinse (as applicable) and dry the Cobalt video baton and then store the equipment in a clean environment.

Cleaning the Video Cables

Wipe the video cables with IPA (70% isopropyl alcohol), bleach (100ppm) or a mild detergent and water.

High Level Disinfection, as stated in Table 2 is required for the video cable when it is visibly soiled.

Cleaning the Monitor

Wipe the exterior of the monitor with IPA (70% isopropyl alcohol), bleach (100ppm) or a mild detergent and water.

Cleaning the Cradle

Wipe the cradle with a standard hospital grade surface cleaning product.

Cleaning and Disinfecting the GlideRite Rigid Stylet

The stylet is a nonsterile reusable device which requires cleaning and High Level Disinfection as defined in the risk analysis – Table 1 on page 45.

1. Clean using a Low Level Disinfection wipe method or rinse/brush method.
2. Using a brush, apply detergent or an enzymatic debridement agent.
3. Rinse under clean, running water for 1 minute.
4. Disinfect the stylet using a High Level Disinfection method as defined in Table 3 on page 48.

Note: For end user convenience it has been determined that the GlideRite® rigid stylet is compatible with the autoclaving cycle in Table 3 on page 48.

Replacing the Monitor Battery

Under normal operating conditions, the battery will last 2 - 3 years, or approximately 500 charge/discharge cycles.

The battery is not user-replaceable. In case of battery malfunction, do not attempt to replace the monitor battery. **Any attempts to replace the battery by unauthorized service technicians will void the warranty.** Please contact your Verathon Medical Customer Care Representative for more information on battery replacement.

O-Ring Replacement

A protective cap is attached to the top of the GlideScope GVL® and on the end of the Cobalt video baton cable. The protective cap contains a rubber O-ring that ensures an effective seal during cleaning and sterilization. Over time, routine use will wear out the O-ring. Replace the O-ring immediately if:

- ◆ Any nicks or tears are visible
- ◆ There is any liquid in the cable connector port after cleaning

To replace an O-ring:

1. Remove the protective cap from the GVL port.
2. On the inside of the protective cap, pick the O-ring out of the groove located at the base of the cap and remove.
3. Then stretch the replacement O-ring around the base of the cap and insert it into the groove (Figure 33). Make sure it is seated securely in the groove. Take care not to nick the O-ring during insertion.

Figure 33. Replacing the O-Ring. O-Ring PN 0120-0335

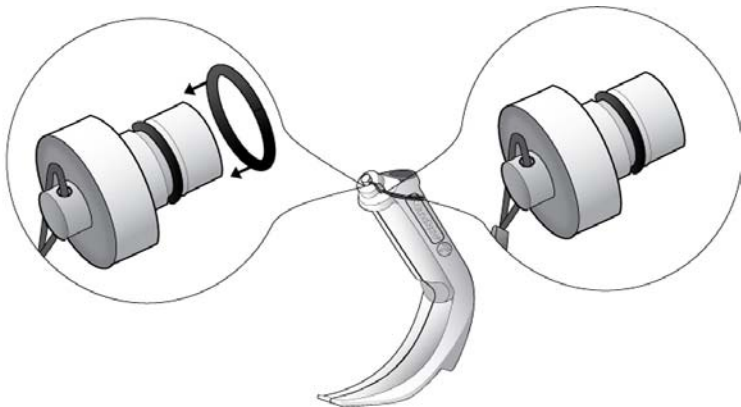

Transportation and Storage

GlideScope system components can be safely used and stored under the environmental conditions specified on page 61.

Figure 34. Prior to shipping, make sure the battery switch is in the OFF position.



IMPORTANT: The battery switch must be in the OFF (left side) position during shipping and storage.

Device Disposal

Disposal of this device can be coordinated through your Verathon Medical Service Center in accordance to the WEEE requirements.

GlideScope Warranty Offerings

Original First Year Total Customer Care Warranty

Verathon® warrants the GlideScope system against defects in material and workmanship. This warranty applies for one (1) year from the date of shipment from Verathon. This warranty is given only to the original purchaser of the GlideScope system.

If a customer's system requires service or repair, Verathon will either replace or provide a loaner unit within one (1) business day from the date of customer service notification. The customer agrees to send the defective unit to Verathon upon receipt of the loaner or replacement unit and agrees to return the loaner unit within two (2) business days of receipt of the repaired unit.

- ◆ This warranty provides coverage for damage from accidental drops or mishandling. It does not cover damage due to deliberate mishandling.
- ◆ This warranty does not apply if the product has been damaged due to, or as the result of, service or modification by anyone other than an authorized Verathon Service Center.
- ◆ This warranty does not apply if there is evidence of the equipment being exposed to temperatures in excess of 60° C.

The product shall be used in accordance with the instructions contained in this User's Manual. Consumable items (e.g., endotracheal tubes, Stats, stylets, etc.) shall be used in conformance with Verathon product specifications. Consumable items are not covered under this warranty.

What is Covered

Warranty coverage is extended to the GlideScope video laryngoscope system:

- ◆ Video monitor including display connector cable and video output cable (VOC)
 - VOC is only covered with an extended warranty for the monitor
- ◆ GlideScope video laryngoscopes (GVL®)
- ◆ Cobalt video batons

Additional GVL laryngoscopes purchased either singularly or as a part of a system must be warranted separately.

Additional video monitors purchased either singularly or as part of a system must be warranted separately.

Premium Customer Care Warranty

The Premium Customer Care warranty from Verathon Medical may be extended for a total of up to six (6) years from date of purchase.

Disclaimer of Additional Warranties

There are no understandings, agreements, representations of warranties expressed or implied (including warranties of merchantability or fitness for a particular purpose) other than those set forth in the preceding Warranty section. The contents of this manual do not constitute a warranty.

Some states disallow certain limitations on applied warranties. The purchaser, user, and patient should consult state law if there is a question regarding this disclaimer. This information, descriptions, recommendations, and safety notations in this manual are based upon Verathon® experience and judgment with GlideScope systems as of September 2008. The contents of this manual should not be considered to be all-inclusive, or to cover all contingencies.

Contact Information

To obtain additional information regarding your GlideScope video laryngoscope system, please contact Verathon Medical Customer Care at:

**Corporate HQ:
(US and Canada)**

Verathon Inc.
20001 North Creek Parkway
Bothell, WA 98011-8128
USA
800.331.2313 (Canada and US)
425.867.1348
Fax: 425.883.2896
<http://www.verathon.com>



Verathon Medical (Europe) B.V.

Linnaeusweg 11
3401 MS, IJsselstein
The Netherlands
+31.30.68.70.570
Fax: +31.30.68.70.512
<http://www.verathon.eu>



Verathon Medical (Canada) ULC

2227 Douglas Road
Burnaby, BC V5C 5A9
Canada
604.439.3009
Fax: 604.439.3039

Parts and Accessories

Table 4. GlideScope system components and accessories.

Description	Orderable Part Number
GlideScope GVL® 5	0574-0030
GlideScope GVL 4	0574-0001
GlideScope GVL 3	0574-0007
GlideScope GVL 2	0574-0010
GlideScope Video Laryngoscope 3-4	0570-0185
GlideScope Video Laryngoscope 1-2	0570-0210
GVL Stat 4, Qty 10	0270-0628
GVL Stat 3, Qty 10	0270-0626
GVL Stat 2, Qty 10	0270-0429
GVL Stat 1, Qty 10	0270-0428
GVL Stat 0, Qty 10	0270-0679
GVL Stat 4, Qty 100	0270-0629
GVL Stat 3, Qty 100	0270-0627
GVL Stat 2, Qty 100	0270-0431
GVL Stat 1, Qty 100	0270-0430
GVL Stat 0, Qty 100	0270-0680
Cobalt Video Baton 3-4 Kit (includes Stat)	0270-0382
Cobalt Video Baton 1-2 Kit (includes Stat)	0270-0608
Portable Video Monitor	0231-0003
GlideRite® Rigid Stylet, Qty 10	0270-0681
GlideRite Auto Stylet, Qty 2	0270-0678
GlideRite DLT Stylet, Qty 10	0270-0674

Description	Orderable Part Number
GlideRite® Guide, Qty 10	0270-0642
GlideScope GVL® Cradle	0810-0126
GlideScope GVL/Cobalt DVR	0270-0625
GlideScope Video Baton Cradle 3-4	0810-0134
GlideScope Video Baton Cradle 1-2	0810-0151
Mobile Stand	0800-0299
Hard Shell Case	0800-0300
IV Pole Mounting Kit	0810-0125
Universal Accessory Basket	0810-0201
O-Ring - Protective Cap	0120-0335
GlideScope Video Cable - 3 pin to 4 pin	0600-0236
GlideScope Video Cable - 4 pin to 4 pin	0600-0237
AC Power Cord 15 ft (4.5 m) - North America	0600-0244
AC Power Cord 2 ft (0.6 m) - North America	0600-0247
AC Power Cord 15 in (4.5 m) - EU	0600-0243
AC Power Cord 2 ft (0.6 m) - EU	0600-0246
AC Power Cord 15 ft (4.5 m) - UK	0600-0245
AC Power Cord 2 ft (0.6 m) - UK	0600-0248
Video Output Cable (for connection to NTSC compatible devices)	0600-0239
GlideScope Video Laryngoscope System User's Manual	0900-1204
GlideScope System Quick Start Quick Reference Card (QRC)	0900-2077
GlideScope GVL/Cobalt Cleaning and Assembly Quick Reference Card	0900-2013
GlideScope 4-Step Tips and Techniques Quick Reference Card	0900-1436
GlideScope GVL/Cobalt QRC Assembly	0900-3173
GlideScope System Cleaning Poster	0900-1429

For full product line, including NEW products, please visit our website at glidescope.com.

Specifications

Verathon® reserves the right to change specifications without notice.

General Specifications

Classification:	Electrical Class I, Applied Part BF
Line Voltage	Range: 100 – 240 VAC, 50 & 60 Hz
Line Current:	MAX 0.50 A
Power Plug:	Hospital Grade
Line Protection:	2A Fuse, Internal

Operating and Storage Conditions

Operating Conditions

Temperature:.....10°C to 40°C

Relative Humidity:.....0 to 95%

Atmospheric Pressure:.....440 to 1060 hPa

Shipping and Storage Conditions

Temperature:.....-20°C to 45°C

Relative Humidity:.....0 to 95%

Atmospheric Pressure:.....440 to 1060 hPa

Charging Conditions

Temperature:.....0°C to 40°C

Relative Humidity:.....0 to 95%

Atmospheric Pressure:.....440 to 1060 hPa

GlideScope® System Components

Portable video monitor:

(320 x 240 pixel) LCD TFT Panel

Monitor:	7in	
Height:	167 mm	
Width:	207 mm	
Depth:	83 mm	
Weight:	1.4 kg	

Mobile stand:

Base height:	13 cm	
Base weight:	2.5 kg	
Base diameter:	61 cm	
Pole height range:	75-119 cm	
Pole weight:	0.7 kg	

IV pole mount:

Weight:	.9 kg	
Arm Length:	27 cm	
Width:	6 cm	

GVL® 5

Length (blade tip to handle):	103 mm	
Height at camera:	14 mm	
Width of camera:	27 mm	

GVL 4

Length (blade tip to handle):	103 mm	
Height at camera:	14 mm	
Width of camera:	27 mm	

GVL 3

Length (blade tip to handle):	82 mm	
Height at camera:	16 mm	
Width of camera:	20 mm	

GVL® 2

Length (blade tip to handle):
 Height at camera:
 Width of camera:

47 mm
 15 mm
 18 mm

**GVL Stat 4**

Length (blade tip to handle):
 Height at camera:
 Width at camera:
 Blade length in front of camera:
 Max blade width in front of camera:

92 mm
 15 mm
 20 mm
 54 mm
 28 mm

**GVL Stat 3:**

Length (blade tip to handle):
 Height at camera:
 Width at camera:
 Blade length in front of camera:
 Max blade width in front of camera:

78 mm
 16 mm
 16 mm
 36 mm
 21 mm

**GVL Stat 2:**

Length (blade tip to handle):
 Height at camera:
 Width at camera:
 Blade length in front of camera:
 Max blade width in front of camera:

56 mm
 9 mm
 11 mm
 28 mm
 16 mm

**GVL Stat 1:**

Length (blade tip to handle):
 Height at camera:
 Width at camera:
 Blade length in front of camera:
 Max blade width in front of camera:

44 mm
 9 mm
 10 mm
 15 mm
 13 mm

**GVL Stat 0:**

Length (blade tip to handle):
 Height at camera:
 Width at camera:
 Blade length in front of camera:
 Max blade width in front of camera:

36 mm
 9 mm
 9 mm
 7 mm
 9 mm



Cobalt video baton 3-4:

Length (Camera tip to SS ring):	104.1 mm
Height of camera:	10.7 mm
Width of camera:	10.9 mm
Cable length:	1676 mm
Weight:	180 g

**Cobalt video baton 1-2:**

Length (Camera tip to handle) (flexible tube):	40 mm
Height of camera:	6 mm
Width of camera:	7 mm
Cable length:	1756 mm
Weight:	130 g

**GlideScope® DVR for GVL®/Cobalt:**

Length:	103.2 mm
Width:	58.2 mm
Height:	32.2 mm
Weight:	~172 g
Max SD card size:	2 GB
Recording on 1 GB SD card:	~1.5 hr

**GlideRite® Rigid Stylet:**

Handle Length:	82 mm
Handle Width:	16 mm
Stylet Rod Length:	266 mm
Distal Tip Diameter:	5 mm

**GlideRite Auto Stylet:**

Handle Length:	110 mm
Handle Width:	25 mm
Stylet Rod Length:	347 mm
Distal Tip Diameter:	5 mm

**GlideRite DLT Stylet:**

Handle Length:	31 mm
Handle Width:	40 mm
Stylet Rod Length:	394 mm
Distal Tip Diameter:	5 mm









Standards and Approvals

- ◆ CMDCAS ISO 13485, Certificate No. 9235
- ◆ EC Certificate for Class I sterile Stats, Certificate No. 41315937
- ◆ MDD Requirements met for Class I and Class I sterile devices
- ◆ CSA Requirements met (Master Contract # 213281), CSA Certificates issued
- ◆ CB Scheme requirements met (CB Bulletin 112a), CB Test Certificates issued
- ◆ CAN/CSA C22.2 No 601.1-M90
- ◆ CAN/CSA C22.2 No. 60601-2-18-01
- ◆ UL Std No 60601-1
- ◆ IEC 60601-2-18
- ◆ CE Mark EMC Directive
- ◆ IEC 60601-1-2
- ◆ CISPR 11
- ◆ VCCI Technical V-3

Symbol Directory

Table 1. Symbol Directory.

Symbol	Meaning
	Type BF equipment
	CE marking in accordance with the Medical Device Directive (CE0413 for Sterile Devices)
	Canadian Standards Association (CSA) mark of certification to applicable standards for electro-medical equipment.
	Tested to Federal Communications Commission Requirements
	Caution – consult accompanying documents. Read instructions before connecting or operating.
	Subject to WEEE (Waste of Electronic Electrical Equipment) regulations.