

110V and 220V

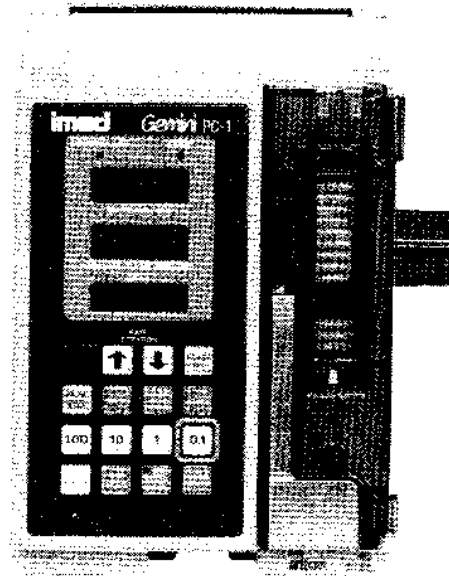

IMED[®] Gemini[®] PC-1[®]
VOLUMETRIC INFUSION PUMP/CONTROLLER
MAINTENANCE MANUAL

MAY 1, 1997



Service Bulletin 414

P/N 141973A

Service Bulletins are supplements to ALARIS Medical's Technical Service/Maintenance Manuals.

Model Affected: Gemini® Volumetric Infusion Pump/Controller, PC-1CE
Date: July 1997
Subject: Release of Model 1310C, PC-1CE

Purpose

The purpose of this bulletin is to provide Biomedical Technicians the following:

- information related to the release of Model 1310C, PC-1CE, and
- updated part number information.

This is *reference information only* and is not intended to suggest a need for component changes.

Explanation

An instrument having Version 8.12 software is referred to as a PC-1CE, Model 1310B. The software has been updated to Version 8.13, and an instrument having this version software is referred to as a PC-1CE, Model 1310C. The only difference between a Model 1310B instrument and Model 1310C instrument is the software.

Version 8.13 software provides the following enhancements over Version 8.12:

- Power up time reduced to approximately 6 seconds (from approximately 11 seconds).
- Control key activation ignored during power up unless the control key is pressed at the same time (or before) POWER ON control key is pressed, and is held until power up sequence is completed.
- "517mmHg" displayed (instead of "10psi") when operating in 10psi mode and selected language is not English.
- SEC/PIGGYBACK control key enabled during secondary infusion and tamper-proof operation.
- Diacritics included in Swedish and German displays.
- Error codes "145" and "146" replaced with the following:

Parts Ordering: Refer to Illustrated Parts Breakdown chapter of the Technical Service/Maintenance Manual
Parts Inquiries: 1-800-854-7128, 1-619-458-6005
Technical Inquiries: 1-800-854-7128, 1-619-458-6003, FAX 1-619-458-7507

Code No.	Description	Meaning	Probable Cause
161-163	Motor Sync Error	Flagged when Display Processor has determined that motor revolution times fail to reflect nominal pumping rate reported by Logic Processor.	Display Board Logic Board
164, 167	Motor Rate Error	Flagged when Display Processor has determined that motor rate fails to reflect nominal pumping rate reported by Logic Processor.	Display Board Logic Board

References

PC-1 Maintenance Manual (*dated September 1, 1995, or later*)

Parts and Tools Required

Reference the appropriate sections of the maintenance manual, if servicing becomes necessary.

Recommended Action

Include the following information, as a supplement to the Illustrated Parts Breakdown chapter of the maintenance manual, when replacing or repairing a PC-1CE display board assembly or logic board assembly in an instrument having Version 8.12 or 8.13 software (Model 1310B or Model 1310C), and when ordering a PC-1CE Operator's Manual.

NOTE: The software version is displayed when the instrument is powered up (scrolls once across the display) and when entering the Setup Mode.

Interchangeability Information

1. Programmed IC

The programmed logic IC (U3) and programmed display IC (U5) must each be the same software version as the other. Replacement parts have been set up to upgrade to Version 8.13 when an order is placed for a Version 8.12 replacement part or assembly. (*See following part number information.*)

2. Operator's Manual

The Operator's Manual used with a Version 8.13 instrument is different than the Operator's Manual used with a Version 8.12 instrument. A new Operator's Manual is provided with each software upgrade kit, but is not provided as part of the logic or display board replacement kit. (*See following part number information.*)

NOTE: When ordering a replacement logic board assembly or display board assembly for a Version 8.12 instrument, it may be necessary to also order an Operator's Manual for a Version 8.13 instrument.

Display and Logic Board Assemblies

(Models 1310B and 1310C, PC-1CE)

NOTE: When ordering a display board assembly, logic board assembly, or software please specify the software version being replaced.

Ref Des	Part Number	Description	Qty.
	142042	Kit, Display Board (Kit consists of Version 8.13 display board assembly, Version 8.13 logic IC, Installation Instructions, and Serial Number Report Instrument Upgrade Form.)	1
	142041	Kit, Logic Board (Kit consists of Version 8.13 logic board assembly, Version 8.13 display IC, Installation Instructions, and Serial Number Report Instrument Upgrade Form.)	1
To replace Version 8.12 software:			
U3, U5		Kit, Upgrade from Version 8.12 to Version 8.13 (Each kit consists of programmed logic IC, programmed display IC, Operator's Manual, Installation Instructions, and Serial Number Report Instrument Upgrade Form.)	1
	141975	Australian	
	141974	English/UK	
	141976	French	
	141977	German	
	141980	Italian	
	141978	Spanish	
	141979	Swedish	
To replace Version 8.13 software:			
U3	141981	IC, Logic, Version 8.13	1
U5	142051	IC, Display, Version 8.13	1

Literature
(Models 1310B and 1310C, PC-1CE)

Part Number	Description	Qty.
	Operator's Manual, 1310B (Version 8.12)	1
10-9259-7	Australian	
10-9254-7	English/UK	
10-9256-7	French	
10-9260-7	German	
10-9258-7	Italian	
10-9255-7	Spanish	
10-9257-7	Swedish	
	Operator's Manual, 1310C (Version 8.13)	1
10-9267-1	Australian	
10-9262-1	English/UK	
10-9268-1	French	
10-9263-1	German	
10-9264-1	Italian	
10-9265-1	Spanish	
10-9266-1	Swedish	



Service Bulletin 412A

P/N 142146A

Service Bulletins are supplements to ALARIS Medical's Technical Service/Maintenance Manuals.

Models Affected: Gemini® Volumetric Infusion Pump/Controller;
1310 (PC-1), 1320 (PC-2), 1325 (PC-2TX), 1340 (PC-4)
Date: July 1997
Subject: Level of Testing Guidelines

 This supersedes Service Bulletin 412, to reflect the release of a new PC-1 Maintenance Manual.

Purpose

The purpose of this bulletin is to provide Biomedical Technicians:

- A Level of Testing Guidelines table, to replace all existing references to testing required after repair (*reference Maintenance chapter of maintenance manual for each Gemini model*).
- Updated maintenance manual part number information (*reference Preface section of maintenance manual for each Gemini model*).

Explanation

The tests currently specified in each maintenance manual as being required after repair may not reflect current testing requirements or recommendations. To help provide the most current minimum test requirements, a Level of Testing Guidelines table has been provided.

The part number referenced in the Preface section of each maintenance manual, as the part number to be used when ordering a manual, is no longer current.

References

Gemini PC-1 Maintenance Manual (*dated September 1, 1995, and later*)
Gemini PC-2 Maintenance Manual (*dated April 1, 1996*)
Gemini PC-2TX Maintenance Manual (*dated May 1, 1996*)
Gemini PC-4 Maintenance Manual (*dated November 1, 1995*)

Parts and Tools Required

As specified in the appropriate sections of the service manual.

Parts Ordering: Refer to Illustrated Parts Breakdown chapter of the Technical Service/Maintenance Manual
Parts Inquiries: 1-800-854-7128, 1-619-458-6005
Technical Inquiries: 1-800-854-7128, 1-619-458-6003, FAX 1-619-458-7507

Recommended Action

Add this Service Bulletin to your Gemini Model PC-1, PC-2, PC-2TX, or PC-4 Maintenance Manual references (as applicable, see above References), as a supplement to the Maintenance chapter.

1. To ensure that all appropriate supplemental documents (such as this service bulletin) are included when receiving a new maintenance manual, use the following part numbers when ordering a manual.

<u>Model</u>	<u>P/N</u>
PC-1	142034
PC-2	141880
PC-2TX	141881
PC-4	141882

2. Any instrument repair or disassembly/reassembly must be followed by testing, determined by the level of the repair/disassembly. Use the following Level of Testing Guidelines, Table 5-5, in place of the test requirements specified in the Maintenance chapter of the maintenance manual.

CAUTION

Turn the instrument off and disconnect it from AC power before disassembly. Static charges will damage instrument circuitry. Observe proper grounding techniques (use grounding strap) to prevent possible harm to static-sensitive components.

Table 5-5 Notes:

- The required tests can be found in the *Maintenance* chapter of the applicable maintenance manual, with the exception of the following test, which can be found in the noted section of the *Preparation for Use* chapter.

<u>Test</u>	<u>Section</u>	<u>Models</u>
Display Test	2.3.3.2: Initial Setup, step 4	PC-2TX, PC-4

- The tests identified as required are for all Gemini models (PC-1, PC-2, PC-2TX, PC-4), unless otherwise noted (next to repair item description).

Table 5-5 Level of Testing Guidelines

Tests to Perform ➔	Electrical Leakage Test	Electrical Ground Test	Low-Flow Height Test	Pump Pressure/ Maximum Pressure Test	Output Pressure Test	Volume/Rate/Time Test	Keypad Test	Lamp Test	Display Test	Strain Beam Calibration	A/D Voltage Display
● – Required											
Repair/Replacement/Adjustment of ↓											
No Fault Found	●	●	●	●							
Air-in-Line Assembly	●	●	●	●	●	●					
Analog Board Assembly: PC-2	●	●	●	●						●	
PC-2TX, PC-4	●	●	●	●							
Anchor Bracket	●	●	●	●							
AC Receptacle Assembly/Power Entry Module	●	●	●	●							●
Audio Oscillator	●	●	●	●							
Battery	●	●	●	●							
Display Board Assembly: PC-1, PC-2	●	●	●	●				●			
PC-2TX, PC-4	●	●	●	●					●		
Door/Door Assembly	●	●	●	●	●	●				●	
Front Case/Assembly Parts	●	●	●	●	●	●				●	
Handle	●	●	●	●							
Harness Assembly (any)	●	●	●	●							
Keypad Assembly	●	●	●	●			●				
Logic Board Assembly: PC-1, PC-2TX	●	●	●	●						●	
PC-2, PC-4	●	●	●	●							
Motor Controller Board Assembly: PC-2TX, PC-4	●	●	●	●						●	
Pole Clamp Assembly	●	●	●	●							●
Power Supply Board Assembly	●	●	●	●							●
Pumping Mechanism Assembly/Parts	●	●	●	●	●	●					
Rear Case/Assembly Parts	●	●	●	●							●
Strain Beam/Transducer Assembly	●	●	●	●	●	●				●	
Transformer Assembly	●	●	●	●							●



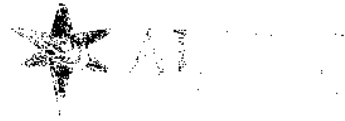

FAX

AD
Department of Defense
Washington, DC 20315-5000
www.dod.mil

Phone: (301) 316-1000
Fax: (301) 316-1000

AD
Department of Defense
Washington, DC 20315-5000
www.dod.mil
Phone: (301) 316-1000
Fax: (301) 316-1000

Reply Urgent Reply Reply Reply Reply

AD

AD has attached a copy of the report for an Imed PC-ITCH serial number 1110 169240

At the time of receiving this unit no accompanying paperwork could be found

Reviewing our history cards, that the unit was originally supplied to the 1st Air Force was the location that we returned the unit to

While at the location the unit was being checked himself. He has attached a copy of the report to be attached

AD

AD
AD







[Faint, illegible text, possibly bleed-through from the reverse side of the page]

1000
1111
1212





Cut and insert
into label holder
on spine of
binder

PC-1



WARNINGS, CAUTIONS AND NOTICES

CAUTION: FEDERAL (USA) LAW RESTRICTS THIS DEVICE TO SALE BY OR ON THE ORDER OF A PHYSICIAN.

USE ONLY HOSPITAL GRADE POWER SUPPLY CORD TO INSURE PROPER GROUNDING. GROUNDING RELIABILITY CAN ONLY BE ACHIEVED BY CONNECTION TO A RECEPTACLE MARKED "HOSPITAL GRADE".

DANGER: EXPLOSION HAZARD, DO NOT USE IN THE PRESENCE OF FLAMMABLE ANESTHETICS.

DANGER: RISQUE D'EXPLOSION, NE PAS EMPLOYER EN PRESENCE D'ANESTHESIQUES INFLAMMABLES.

WARNING: TO PREVENT UNRESTRICTED FLOW, CLOSE CLAMP WHEN FLO-STOP IS OPEN.



CAUTION: TO REDUCE RISK OF ELECTRICAL SHOCK, DO NOT REMOVE COVER OR BACK. REFER SERVICING TO QUALIFIED SERVICE PERSONNEL.



WARNING: REPLACE FUSE AS MARKED.



CAUTION: BEFORE CONNECTING "REFER TO MANUAL"

NOTE

TO MAXIMIZE THE SERVICE LIFE OF THE INSTALLED BATTERY, IT IS RECOMMENDED THAT THIS INSTRUMENT BE STORED AND OPERATED IN AN ENVIRONMENT THAT IS TEMPERATURE CONTROLLED BETWEEN 68°F (20°C) AND 77°F (25°C).

WARNING

IN THE EVENT THE INSTRUMENT IS DROPPED AT ANY TIME, IT MUST BE CHECKED BY A BIOMEDICAL TECHNICIAN PRIOR TO USE FOR PATIENT CARE.



WARNING AND CAUTION NOTICES

220V

WARNING: TO PREVENT UNRESTRICTED FLOW, CLOSE ROLLER CLAMP WHEN FLO-STOP[®] MECHANISM IS OPEN.



CAUTION: REFER TO MANUAL



CLASS 1

TYPE CF (Equipment useable for direct cardiac applications)



ALTERNATING CURRENT



REPLACE FUSE ONLY WITH SAME TYPE AND RATING



EQUIPOTENTIAL GROUND POINT: IF THE INTEGRITY OF THE EQUIPOTENTIAL EARTH CONNECTION OR HOSPITAL EARTH SYSTEM IS IN QUESTION, OPERATE THE INSTRUMENT USING INTERNAL BATTERY POWER.

IPX1

DRIP PROOF

WARNING

If the PC-1 pump/controller is dropped at any time, have the instrument checked by the Biomedical Department prior to further use.

CAUTION

ONLY equipment that has been qualified to IEC 601-1 standards should be connected to the PC-1 pump/controller's RS-232-C Data Port and the connection should ONLY be performed by qualified personnel.

CAUTION

Only systems that have been qualified to IEC 601-1 standards should be connected to the PC-1 pump/controller's Nurse Call connector and the connection should ONLY be performed by qualified personnel.



NOTICE

Product design and/or specifications are subject to change without notice. The information contained in this manual is current as of the date of issue.

This publication contains ALARIS Medical Systems, Inc. ("ALARIS Medical") proprietary data provided solely for the use of technical personnel in repairing ALARIS™ Medical infusion pump/controllers.

None of the information contained herein may be duplicated nor may it be utilized in any manner other than for the repair and maintenance of ALARIS™ Medical infusion pump/controllers and the component parts thereof. Any unauthorized use of the information contained herein may subject the user to substantial liability.

Copyright© 1997 by ALARIS Medical Systems, Inc.

All Rights Reserved
10221 Wateridge Circle
San Diego, CA 92121
(619) 458-7000
Printed in U.S.A.

U.S. Patents 4,617,014; 4,690,673; 4,689,043; 4,725,205; 4,728,265; 4,836,752; D305,151; D308,946;
D312,879; 4,954,046; 5,219,330; 4,859,927; 4,909,710
Other U.S. and Foreign Patents Issued and Pending



PREFACE

This manual contains operation and maintenance instructions for the IMED GEMINI PC-1[®] Volumetric Infusion Pump/Controller. The information provided herein is intended for use by technical personnel responsible for servicing this product. The material is divided into six sections and is presented as follows: Section 1 - Descriptive Information; Section 2 - Preparation for Use; Section 3 - Operating Instructions; Section 4 - Functional Description and Schematic Diagrams; Section 5 - Maintenance Instructions; Section 6 - Parts Lists and Assembly Drawings.

Additional copies of this manual may be obtained by contacting ALARIS Medical's Customer Service Department and ordering ALARIS Medical Part No. 10-9261-00.

This manual supersedes PC-1 Maintenance Manual 1310-9251-00 and PC-1 International Addendum P/N 1310-9028-00.

The features of the 220V model of the PC-1 pump/controller have been incorporated into this manual. Text or graphics that are related exclusively to the 220V model are identified with a **220V** symbol.

In addition, some features are for the 110V model of the PC-1 pump/controller only and are identified with a **110V** symbol.

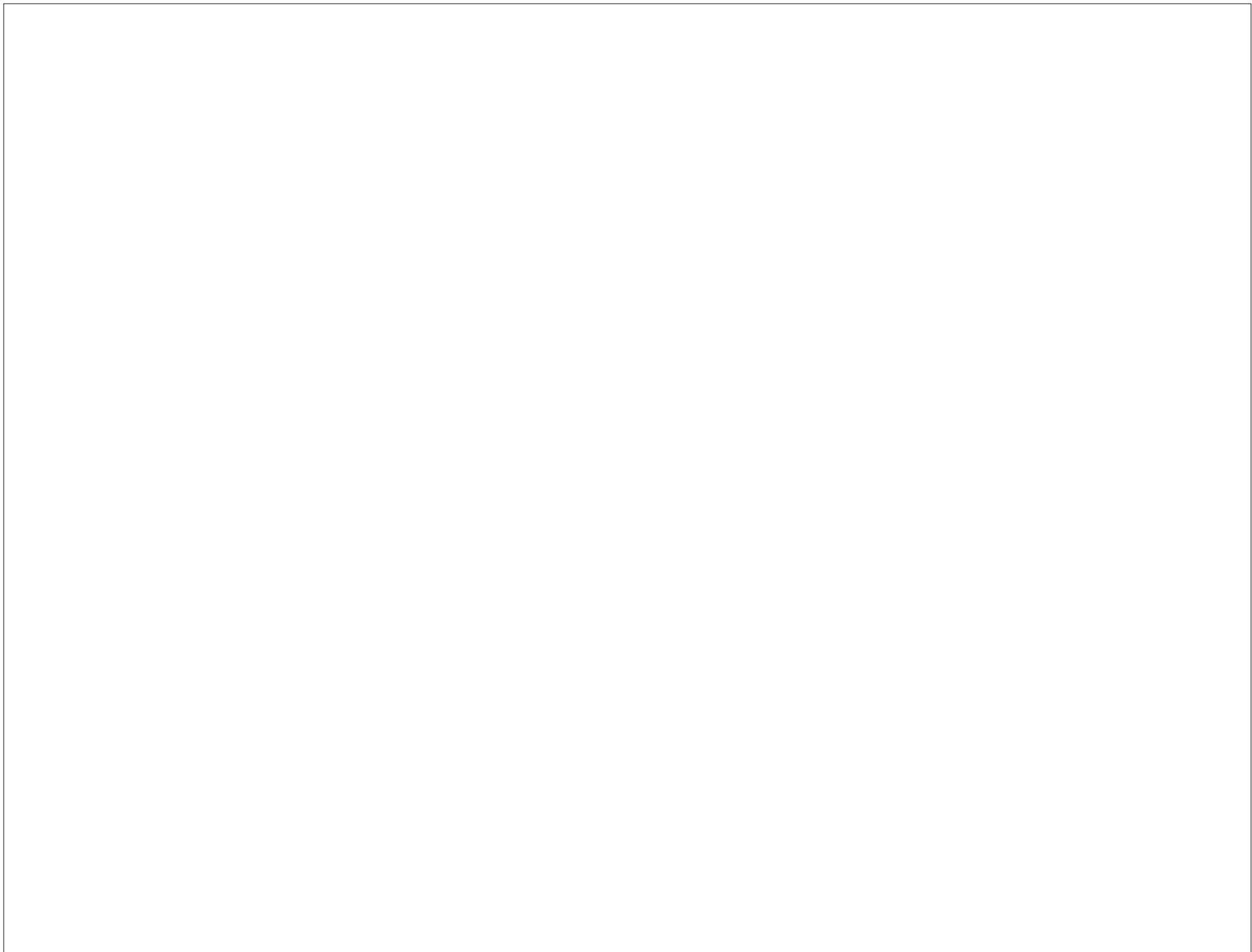

RECORD OF CHANGES

Date	Description of Change	By
05/01/97	Initial Issue	HRL/TW



TABLE OF CONTENTS

SECTION 1 - DESCRIPTION

- 1.1 Introduction 1-1
- 1.2 Operating Characteristics 1-1
- 1.3 Operating Condition 1-2
- 1.4 User Interface 1-3
- 1.5 Physical Description 1-4
- 1.6 Operating Specifications 1-4
- 1.7 Administration Sets 1-4
- 1.8 Accessories 1-4

SECTION 2 - PREPARATION FOR USE

- 2.1 Introduction 2-1
- 2.2 Pre-Operational Mechanical Inspection 2-1
- 2.3 Operational Performance Check 2-3
- 2.3.1 Pre-operational Check Battery Charge 2-3
- 2.3.2 Pre-operational Electrical Inspection 2-3
- 2.3.2.1 Electrical Leakage Test 2-3
- 2.3.2.2 Electrical Ground Test 2-3
- 2.3.3 Abbreviated Operational Performance Test 2-3
- 2.3.3.1 Test Requirements 2-3
- 2.3.3.2 Test Procedures 2-4

SECTION 3 - OPERATION

- 3.1 Introduction 3-1
- 3.2 Controls and Indicators 3-1
- 3.3 Operating Conditions 3-9
- 3.3.1 Normal and Computer Operation 3-9
- 3.3.1.1 Pump and Controller Modes 3-9
- 3.3.1.2 VersaTaper[®]/AutoTaper[®] Mode Operation 3-17
- 3.3.1.3 Battery Powered Operation 3-23
- 3.3.2 Maintenance/Diagnostic Mode 3-24
- 3.4 Operator Information Display and Alarm Response Procedures 3-25
- 3.5 Audio Alert System 3-25

SECTION 4 - PRINCIPLES OF OPERATION

- 4.1 Introduction 4-1
- 4.2 Mechanical Operation 4-1
- 4.2.1 Physical Description 4-1
- 4.2.1.1 Pumping Mechanism 4-1
- 4.2.1.2 Strain Beam (Pressure Transducer) 4-1
- 4.2.2 Functional Operation 4-1
- 4.2.2.1 Pumping Mechanism 4-1
- 4.2.2.2 Strain Beam (Pressure Transducer) 4-5
- 4.3 Electrical/Electronic Operation 4-5
- 4.3.1 Functional Description 4-5
- 4.3.2 Functional Operation 4-7

PC-1

4.3.2.1	Power On/Power Off Subsystem	4-8
4.3.2.2	Auto Power On Subsystem	4-8
4.3.2.3	5 Volt Protected Subsystem	4-8
4.3.2.3a	5V Power Supply (-7023 Power Supply Board)	4-8
4.3.2.4	±12 Volt DC Power Supply Subsystem	4-11
4.3.2.4a	±8 Volt DC Power Supply Subsystem	4-11
4.3.2.5	Battery Charger Subsystem	4-11
4.3.2.5a	Dual State Battery Charger (Charger Adapter CCA)	4-12
4.3.2.5b	Dual State Battery Charger (-7023 Power Supply Board)	4-12
4.3.2.6	System Reset Circuit	4-14
4.3.2.7	Battery Depleted Circuit	4-14
4.3.2.8	Pumping Mechanism	4-16
4.3.2.9	Strain Beam	4-24
4.3.2.10	Air-In-Line Detector	4-26
4.3.2.11	Slide Clamp Detector	4-27
4.3.2.12	Door Sensor	4-27
4.3.2.13	Audio Subsystem	4-29
4.3.2.14	Display Subsystem	4-29
4.3.2.15	Communications Interface and Signal Definitions	4-31
4.3.2.16	Maintenance Mode	4-31
4.3.2.17	Empty Container Detector (ECD) All except V8.xx	4-33
4.3.2.17a	Empty Container Detector (Universal) All except V8.xx	4-33

SECTION 5 - MAINTENANCE

5.1	Introduction	5-1
5.2	Preventive Maintenance	5-1
5.2.1	Cleaning Instructions	5-1
5.2.2	Mechanical Inspection	5-2
5.3	Maintenance/Diagnostics Mode	5-2
5.3.1	Maintenance/Diagnostics Mode Operation	5-2
5.3.1.1	Maintenance/Diagnostics Mode Test Sequence	5-3
5.3.2	Maintenance Mode Test Suite	5-3
5.4	Troubleshooting	5-10
5.5	Disassembly	5-43
5.5.1	Separating the Case (Figure 6-1)	5-43
5.5.2	Front Case Disassembly (Figure 6-2b)	5-43
5.5.2.1	Circuit Card Removal and Disassembly (Figure 6-2b)	5-43
5.5.2.2	Pumping Mechanism Assembly Removal (Figure 6-2b)	5-44
5.5.2.3	Door Sensor Assembly Removal (Figure 6-2a)	5-44
5.5.2.4	Air/SCD Assembly Removal and Disassembly (Figure 6-2a)	5-44
5.5.2.5	Transducer Assembly Removal (Figure 6-2a)	5-44
5.5.2.6	Anchor Bracket Assembly Removal (Figure 6-2b)	5-44
5.5.2.7	Door Assembly Removal and Disassembly (Figures 6-2c and 6-3)	5-45
5.5.2.8	Pump Seal Removal (Figure 6-1b)	5-45
5.5.2.9	Snap Bracket Removal (Figure 6-2c)	5-45
5.5.2.10	Keypad/ESD Shield Assembly Removal (Figure 6-2a)	5-45
5.5.3	Rear Case Disassembly	5-45
5.5.3.1	Battery Removal (Figure 6-1a)	5-45
5.5.3.2	Battery Bracket Removal (Figure 6-1a)	5-46
5.5.3.3	Transformer Harness Assembly Removal (Figure 6-8)	5-46
5.5.3.4	AC Power Input Module Assembly Removal (Figure 6-8)	5-46

5.5.3.4a	Charger Adapter CCA Removal (Instruments with the Dual State Charger Modification Kit P/N5-1310-1901-1 installed)	5-46
5.5.3.5	Power Supply Board Removal	5-46
5.5.3.6	Pole Clamp Assembly Removal and Disassembly (Fig. 6-1a)	5-46
5.5.3.7	Removal of the Power Cord Strap (Figure 6-1c)	5-47
5.5.3.8	Grounding Stud Removal	5-47
5.6	Reassembly	5-47
5.7	Calibration Procedures	5-48
5.7.1	Strain Beam Calibration	5-48
5.7.1.1	Calibration Equipment Requirements	5-48
5.7.1.2	Calibration Procedures	5-48
5.7.2	AIL Detector Calibration	5-50
5.8	Comprehensive Operational Performance Test	5-50
5.8.1	Electrical Inspection	5-50
5.8.1.1	Electrical Leakage Test	5-50
5.8.1.2	Electrical Ground Test	5-50
5.8.1.3	Dielectric Test (Optional)	5-50
5.8.1.4	Battery Voltage Check	5-50
5.8.1.5	Battery Care and Maintenance	5-51
5.8.2	Qualitative Operational Performance Test	5-51
5.8.2.1	Operational Performance Test	5-51
5.8.2.2	VTBI Display Validity Check	5-51
5.8.3	Quantitative Operational Performance Test	5-51
5.8.3.1	Equipment Requirements	5-51
5.8.3.2	Initialization Setup	5-52
5.8.3.3	Pump Mode Tests	5-53

SECTION 6 - ILLUSTRATED PARTS BREAKDOWN

6.1	INTRODUCTION	6-1
-----	--------------	-----

WARRANTY

INTERNATIONAL OFFICES

PC-1

LIST OF FIGURES

Figure	Title	Page
1-1	IMED® Gemini PC-1® Volumetric Infusion Pump/Controller	1-0
1-2	Audio Characteristics	1-8
2-1	PC-1 Front and Rear Operating Features	2-2
2-2	Communications Emulator Plug	2-4
2-3	Air-In-Line Simulator	2-8
2-4	PC-1 Test Data Sheet	2-9
3-1	PC-1 Front Panel Controls and Indicators	3-2
3-1a	PC-1 Titration Front Panel Controls and Indicators	3-3
3-2	PC-1 Rear Panel Controls and Indicators	3-4
4-1	PC-1 Pumping Mechanism	4-2
4-2	Functional Block Diagram [v2.xx/5.xx/6.xx]	4-3
4-2a	Functional Block Diagram [v7.xx]	4-4
4-3	Cross Section of Strain Beam Assembly	4-5
4-4	PC-1 Interconnect Diagram	4-6
4-4a	PC-1 (220V) Interconnect Diagram	4-6a
4-5	Microprocessor Timing Waveforms	4-7
4-6	Power ON/OFF, Auto Power On and Sensor Signal Functional Schematic [v2.xx/5.xx/6.xx]	4-9
4-7	5 Volt Protected Circuit Functional Schematic [v2.xx/5.xx/6.xx]	4-10
4-8	±12 Volt Power Supply Functional Schematic [v2.xx/5.xx/6.xx]	4-13
4-8a	Charger Adapter Board Schematic (with Mod Kit P/N 1310-1901-1 installed)	4-13
4-9	System Reset Functional Schematic [v2.xx/5.xx/6.xx]	4-15
4-10	Stator Polarity Change as a Function of Phase Excitation	4-16
4-11	Relationship of Stator and Rotor Teeth with the A Phase Energized	4-16
4-12	Battery Charger Functional Schematic (without Dual State Charger)	4-17
4-12a	Battery Charger Functional Schematic 1310-7023 Pwr Sup Brd (Dual State Charger)	4-18
4-12b	Power Supply CCA [v7.xx] (Sheet 1)	4-19
4-12b	Power Supply CCA [v7.xx] (Sheet 2)	4-20
4-12c	Power Supply CCA with Crowbar/Timer (PC-1CE V8.xx) P.N. 1310-5036-3/4 (Sheet 1)	4-21
4-12c	Power Supply CCA with Crowbar/Timer (PC-1CE V8.xx) P.N. 1310-5036-3/4 (Sheet 2)	4-22
4-13	Pumping Mechanism Functional Schematic [v2.xx/5.xx/6.xx]	4-23
4-14	Input Signal Pulses and Change in Phase Excitation of Unipolar Drive	4-24
4-15	Strain Beam Functional Schematic [v2.xx/5.xx/6.xx]	4-25
4-16	AIL Detector Cross Section	4-26
4-17	Slide Clamp Detector Cross Section	4-27
4-18a	Hybrid AIL/SCD Board Schematic	4-27
4-18b	AIL/SCD PCB Schematic (1310-5000)	4-28
4-18c	AIL/SCD Schematic (1310-5012)	4-28
4-18d	AIL/SCD PCB Schematic (1310-5024)	4-29
4-19	PC-1 Audio Subsystem [v2.xx/5.xx/6.xx]	4-30
4-21	Communications Interface Functional Schematic	4-31
4-22	ECD Schematic (P/N 1301)	4-33
4-22a	ECD (Universal) Schematic (P/N 1308)	4-34
4-20	Display CCA Schematic [v2.xx/v5.xx]	4-35
4-20a	Display CCA Schematic [v6.xx]	4-36
4-20b	Display CCA Schematic [v7.xx] P.N. 1310-5033	4-37
4-20c	Display CCA Schematic [PC-1CE v8.xx] P.N. 1310-5042 (Sheet 1)	4-38
4-20c	Display CCA Schematic [PC-1CE v8.xx] P.N. 1310-5042 (Sheet 2)	4-39
4-23	Microprocessor Interface Schematic [v2.xx/5.xx/6.xx] (Sheet 1)	4-40
4-23	Microprocessor Interface Schematic [v2.xx/5.xx/6.xx] (Sheet 2)	4-41

PC-1

4-23	Microprocessor Interface Schematic [v2.xx/5.xx/6.xx] (Sheet 3)	4-42
4-24	Logic CCA Schematic [v7.xx] P.N. 1310-5026 (Sheet 1)	4-43
4-24	Logic CCA Schematic [v7.xx] P.N. 1310-5026 (Sheet 2)	4-44
4-24	Logic CCA Schematic [v7.xx] P.N. 1310-5026 (Sheet 3)	4-45
4-24a	Logic/Analog CCA Schematic [PC-1CE v8.xx] P.N. 1310-5044 (Sheet 1)	4-46
4-24a	Logic/Analog CCA Schematic [PC-1CE v8.xx] P.N. 1310-5044 (Sheet 2)	4-47
4-24a	Logic/Analog CCA Schematic [PC-1CE v8.xx] P.N. 1310-5044 (Sheet 3)	4-48
5-1	Universal Test Station Setup	5-56
5-2	Air-In-Line Simulator	5-57
5-3	PC-1 Test Data Sheet	5-58
6-1a	Parts Identification PC-1 Final Assembly	6-3
6-1b	Parts Identification PC-1 Final Assembly	6-4
6-1c	Parts Identification PC-1 Final Assembly	6-5
6-2a	Parts Identification Front Case Assembly	6-8
6-2b	Parts Identification Front Case Assembly	6-9
6-2c	Parts Identification Front Case Assembly	6-10
6-3	Parts Identification Door Assembly	6-12
6-4	Parts Identification Logic CCA [v7.xx] PN 1310-7026-2	6-17
6-5	Parts Identification Logic CCA [v8.12] PN 1310-7046-1	6-18
6-6	Parts Identification Display Circuit Card Assembly [v7.xx] PN 1310-7033-3	6-21
6-7	Parts Identification Display Circuit Assembly [v8.12] PN 1310-7044-1	6-22
6-8	Parts Identification Rear Case Assembly	6-24
6-9	Parts Identification Power Supply CCA [v7.xx] PN 1310-5036-3	6-29
6-10	Parts Identification Power Supply CCA [v8.12] PN 1310-7036-7	6-30

PC-1

LIST OF TABLES

Table	Title	Page
1-1	Operating Requirements	1-5
1-2	Performance Specifications	1-5
1-3	Administration Sets	1-9
1-4	Accessories	1-9
3-1	PC-1 Controls and Indicators	3-5
3-2	PC-1 Status/Alarm Displays	3-26
4-1	RS-232-C Communications Data Port Signal Definitions	4-32
5-1	Troubleshooting/Fault Isolation Guide	5-10
5-2	PC-1 Error Log Codes (V2.xx, V5.xx, V6.xx, and V6.3x4x)	5-14
5-2a	PC-1 Error Log Codes (V7.xx)	5-22
5-2b	PC-1 Error Log Codes (V8.xx)	5-33
5-2z	PC-1 Maintenance Mode Error Codes (v5.xx/v6.xx/v7.xx/v8.xx)	5-42
5-3	Table of Torque Values	5-47
6-1	Parts List - PC-1 Final Assembly	6-2
6-1a	Parts List - PC-1 Final Assembly	6-3
6-2	Parts List - Front Case Assembly	6-6
6-3	Parts List - Door Assembly	6-11
6-4	Parts List - Logic Circuit Card Assembly [v7.xx & subsequent]	6-13
6-5	Parts List - Display Circuit Card Assembly [v7.xx & subsequent]	6-19
6-6	Parts List - Rear Case Assembly	6-23
6-7	Parts List - Power Supply Circuit Card Assembly for [v7.xx & subsequent]	6-25

THIS PAGE INTENTIONALLY LEFT BLANK

PC-1

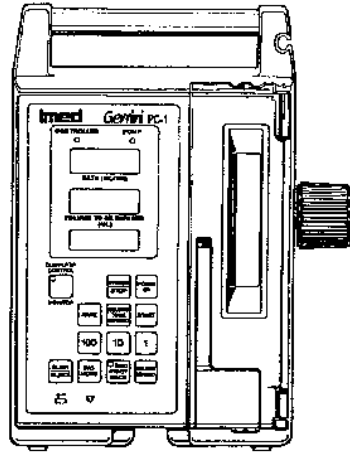

Integer Keypad

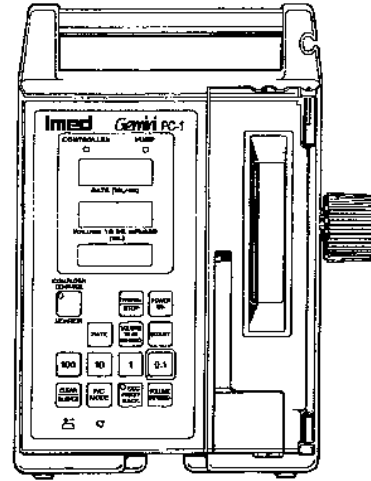

Fractional Keypad

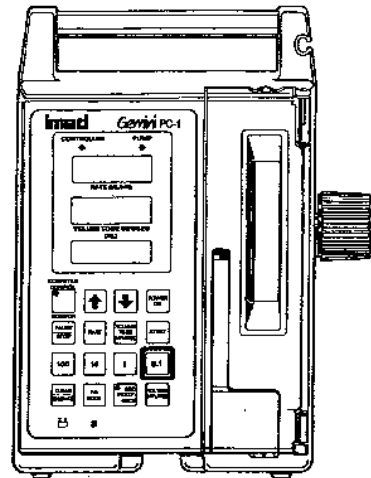

Titration Keypad

Figure 1-1 IMED® GEMINI PC-1® Volumetric Infusion Pump/Controller

SECTION 1 - DESCRIPTION**1.1 INTRODUCTION**

This section includes general operating characteristics, physical description and operating specifications for the IMED GEMINI Model PC-1 Volumetric Infusion Pump/Controller.

1.2 OPERATING CHARACTERISTICS

The GEMINI Model PC-1 instrument is a single channel volumetric infusion pump/controller used for the administration of intravenous drugs and fluids. The instrument can be operated as either a Pump or Controller. A lockout feature is incorporated which allows the instrument to be preset as either a Pump or Controller. Secondary (piggyback) infusions can be administered using infusion parameters independent of the Primary infusion. An Empty Container Detector (ECD) is available, as an option (All except PC-1CE v8.xx 220V), to permit infusing the entire contents of an IV solution container. The instrument is compatible with remote computer operation when the communication option is installed. An integral maintenance mode is incorporated to monitor instrument performance, identify and document instrument malfunctions and assist technical personnel in troubleshooting and repair.

Fractional Keypad/Series V5.xx & Subsequent Software

A VersaTaper[®] Mode is incorporated to facilitate administration of IV fluids that require non-linear delivery (rate and/or VTBI) during the period of medication. Twenty, manually input, independent steps (rate and VTBI combinations) are available to set up a tapered infusion program.

Titration Keypad/Series V7.xx & Sub. Software

An AutoTaper[®] Mode is incorporated to automate infusion setup and delivery of ramp-up/taper-down cyclic parenteral nutrition applications.

The PC-1 pumping mechanism employs linear peristaltic action to deliver a continuous flow of infusion products reliably, accurately and safely. In the controller mode, the instrument will deliver fluid at a pressure equal to the pressure created by the head height of the IV solution container ± 12 inches (30 cm). In the pump mode, the instrument delivers fluid at a pressure up to a maximum of 10 ± 2 psi (69 ± 14 kPa; 517 ± 103 mmHg). Above these pressures, the instrument will occlude.

Integer Keypad/Series V2.xx Software

Infusion rate is selectable between 1 and 999 mL/hr in 1 mL/hr increments. Volume to be infused (VTBI) is selectable between 1 and 9999 mL in 1 mL increments. When an infusion is complete, the instrument automatically switches to the KVO rate of 1 mL/hr.

Fractional Keypad/Series V5.xx & Sub. Software

Infusion rate and VTBI are dependent on the selected instrument operating mode - Micro, Macro or Universal. Available parameters are as follows:

MICRO (mic) - Rate is selectable between 0.1 and 99.9 mL/hr in 0.1 mL/hr increments; VTBI is selectable between 0.1 and 999.9 mL in 0.1 mL increments.

MACRO (mac) - Rate is selectable between 1 and 999 mL/hr in 1 mL/hr increments; VTBI is selectable between 1 and 9999 mL in 1 mL increments.





UNIVERSAL (mic/mac) - Rate is selectable in 0.1 mL/hr increments between 0.1 and 99.9 and in 1 mL/hr increments between 100 and 999 mL/hr; VTBI is selectable in 0.1 mL increments between 0.1 and 999.9, when the Rate is fractional, and otherwise in 1 mL increments between 1 and 9999 mL.

When an infusion is complete, the instrument automatically switches to a KVO rate of 1 mL/hr for delivery rates ≥ 1 mL/hr or a rate equal to the set delivery rate for rates < 1.0 mL/hr.

PC-1

This version of the PC-1 pump/controller incorporates a feature that allows the instrument to be preset in either the Micro (mic), Macro (mac) or Universal (mic/mac) mode.

Rate Titration Keypad/Series v7.xx

The Rate Titration feature allows the rate to be increased or decreased 1 mL/hr (MACRO mode) or 0.01 mL/hr (MICRO mode) with each press of the  or  control, then press START to accept the new rate. Greater rate changes can be achieved by pressing and holding the appropriate   controls until the desired rate is obtained, then press START to accept the new rate.

The PC-1 pump/controller does not require any pre-operational warm up. An internally mounted battery provides normal operation for a limited period to enable use when AC power is not available or the external power source is interrupted.

The PC-1 pump/controller's user interface consists of a front panel tactile keypad and the rear panel Audio Control potentiometer. Tamper resistant operation is provided through the requirement to utilize a prescribed key press sequence to enter or change infusion parameters. Basic operating instructions are printed on the right side of the instrument case. Functional control is provided by a 16 bit microprocessor using a stored program that includes a diagnostic routine that monitors pump performance, provides audio and visual signals to ensure proper sequencing of normal operations and initiates an alarm in the event a software or hardware malfunction is detected.

Sufficient disposable configurations are available to provide the user with a full range of set-up combinations (see Section 1.7). The Flo-Stop[®] on the GEMINI administration set's pumping segment prevents free flow in the event the tubing set is removed from the instrument following initial installation. Free flow, as a result of deliberate operator action, is possible when using the set to perform a gravity infusion in accordance with the instructions provided in the set package.

1.3 OPERATING CONDITION

The PC-1 pump/controller can be operated independently (Normal Operation) or, when configured with a communication data port, as a computer controlled device (Computer Operation). Normal operation includes the Controller and Pump modes plus the Maintenance mode. Computer operation includes the Monitor and Computer Control modes.

NORMAL OPERATION

SETUP MODE V7.xx and subsequent software

The Titration keypad instruments utilize the Setup Mode (refer to Section 2.3.3.2) to configure the instrument for specific infusion regimes, language selection and communication (serial port) parameters.

CONTROLLER MODE

In the CONTROLLER mode, the PC-1 pump/controller is programmed to control the infusion of a specific volume of IV solution. The instrument senses and responds to container height and patient-side pressure in a manner similar to a gravity infusion. The instrument's pressure sensor measures the hydrostatic pressure from the fluid container and compares that pressure against distal tubing in-line pressure. When in-line pressure exceeds pump input pressure, an occlusion condition exists and an alarm is initiated. Actual delivery pressure is directly proportional to container height; increasing container height raises and decreasing the height reduces occlusion pressure. Controller mode occlusion pressure tolerance is ± 12 inches (30.54 cm) from the fluid container height. Transient surges in patient-side pressure above the occlusion threshold of <60 seconds duration will produce a LOW FLOW condition which stops the infusion while the pressure is above the occlusion threshold. Pressure transients above the occlusion threshold for periods longer than 60 seconds duration or cumulative time required to compensate for volumetric deficiency in excess of 30 minutes will initiate an occlusion alarm.

PUMP MODE

In the PUMP mode of operation, the instrument employs a preset occlusion pressure limit of 10 ± 2 psi (69 ± 14 kPa; 517 ± 103 mmHg) predicated on a nominal container height of 24 inches (61 cm) and a delivery rate >30 mL/hr. For delivery rates <30 mL/hr, the occlusion pressure is rate-dependent to ensure timely detection of occlusion conditions. Any transient distal in-line pressure above this limit will generate a patient-side occlusion alarm.

Software Release V6.xx and Subsequent

These instruments can be locked into a rate-independent (10 psi) occlusion pressure mode. This mode will result in significantly increased time-to-occlusion for rates <30 mL/hr.

Software Release v8.13 only

These instruments can be locked into a rate-independent (517 mmHg) occlusion pressure mode. This mode will result in significantly increased time-to-occlusion for rates <30 mL/hr.

MAINTENANCE/DIAGNOSTIC MODE**Integer/Fractional Keypad Instruments**

The Maintenance mode is intended solely for use by biomedical technicians to perform servicing and maintenance actions and must **NEVER** be used when the PC-1 pump/controller is connected to a patient. The maintenance mode provides biomedical service personnel access to the closed loop diagnostic test routines and allows the pumping mechanism to be operated unencumbered by stoppages resulting from alarm and malfunction conditions. Specific sub-routines are incorporated in the maintenance test sequence to permit configuring the instrument for non-English language and computer operation (see Section 5.3 for detailed operation).

Titration Keypad Instruments

The Diagnostic mode provides biomedical service personnel access to the closed loop diagnostic routines, allows the pumping mechanism to be operated uninterrupted by stoppages resulting from alarm conditions and maintains a log of the 24 most recent error codes (see Section 5.3 for detailed operation).

COMPUTER OPERATION**Fractional/Titration Keypads with Software Release V6.xx and Subsequent ONLY****MONITOR MODE**

The Monitor mode allows a host computer to monitor infusion status and instrument performance. Monitor mode is enabled when a host computer is connected to the PC-1 pump/controller through the Communications Data Port (RS-232-C) and the Monitor indicator is illuminated.

COMPUTER CONTROL

The Computer Control mode allows an infusion, once set up, to be controlled and monitored by a host computer installation. Computer controlled operation is selected by actuating the COMPUTER CONTROL/MONITOR switch after Monitor mode has been established. Computer controlled operation is confirmed by the computer control indicator presentation changing from flashing to a steady illumination.

1.4 USER INTERFACE

The front Control and Display panel incorporates a tactile keypad for operator use in programming an infusion. Delivery mode (if not locked), Rate and Volume to be infused are each selected for Primary infusions. A SEC/PIGGYBACK (Secondary) key permits independent selection of Rate and VTBI for a sequential secondary infusion. Separate registers are provided to accumulate Total and Secondary volume infused quantities. The PAUSE/STOP control allows an infusion to be "paused" and then resumed or stopped. Rate and VTBI infusion parameters for the Primary or Secondary are displayed digitally in the respective displays. The operator information display presents visual prompts, advisories, alarms and/or malfunctions messages as appropriate to assist the operation in programming and operating the instrument.



Fractional Keypad/Series V5.xx & Sub. Software

The 0.1, 10, 100, VTBI, VI, PC and CLEAR/SILENCE keys have a secondary function during instrument power up to enable or clear

PC-1

discrete delivery mode selections available on these versions of the PC-1 pump/controller.

Titration Keypad/Series V7.xx & Sub. Software

The keypad adds the rate titration controls  and  which enable the user to quickly increase or decrease the rate parameter. A tamper resistance feature is enabled in the SETUP mode and implemented using the push actuation of the Audio/Tamper Resistance Control on the rear panel.

The requirement to properly install the administration set's integral Flo-Stop before the door will close and latch prevents inadvertent "free flow," inhibits premature operation of the pump and prohibits use of an unauthorized set. The Door Open and Air-in-Line sensors are provided to stop pump operation if either of these conditions occur during an infusion. A strain relief fitting is provided in the instrument's handle support to prevent kinking of the proximal tubing.

The rear panel of the PC-1 pump/controller is configured with an audio volume control and an ECD connection (ECD connection - All except PC-1CE v8.xx 220V). A RS-232-C data port connector is incorporated on the power supply board for the Fractional Keypad instruments. Software releases V6.xx and subsequent enable the PC-1 pump/controller for computer controlled operation.

iMED GEMINI Series disposable administration sets are required for use with the GEMINI family of Infusion Pump/Controllers. Sufficient set types are available to support a broad range of infusion types and configurations.

1.5 PHYSICAL DESCRIPTION

The PC-1 instrument has the following physical characteristics:

Height: 10.8 inches (27.5 cm)
Width: 8.4 inches (21.3 cm) w/pole clamp
Depth: 6.5 inches (16.5 cm) w/pole clamp
Weight: 11.1 pounds (5.1 kg)

The PC-1 instrument consists of two major assemblies: the front and rear case.

FRONT CASE

The front case assembly consists of a high-impact, injection molded, plastic case/insert assembly with an Electro-Static Discharge (ESD) coating, which houses and supports the pumping chamber access door, the peristaltic pumping mechanism, pressure transducer (strain beam), Air-in-line and slide clamp detectors, the multi-card assembly, keypad and front case ESD components.

REAR CASE

The rear case assembly consists of a die-cast aluminum shelf which mounts and supports internally the battery, transformer, power supply board (with sonalert), ECD connector (except PC-1CE v8.xx 220V), audio control potentiometer and RS-232-C connector) and power entry module. The exterior of the rear case supports the pole clamp, ECD storage fitting, power cord retention strap and power cord retainer.

220V only. The exterior of the rear case supports the 220V AC power entry module plus the equipotentiality grounding point. The power entry module includes fuses for both input leads and a 220V AC power interrupt switch (where applicable).

1.6 OPERATING SPECIFICATIONS

The GEMINI PC-1 Operating Specifications are subordinated into Operating Requirements and Performance Specifications which are delineated in Tables 1-1 and 1-2, respectively.

1.7 ADMINISTRATION SETS

The administration sets available for use with the GEMINI PC-1 pump/controller[®] are listed in Table 1-3.

1.8 ACCESSORIES

The accessories approved for use with the GEMINI PC-1 pump/controller are listed in Table 1-4.

Table 1-1. Operating Requirements

Parameter	Specification
Power Required:	<p>Non-Dual State Charger Instruments 90-132 VAC, current draw 0.2 Amps maximum (25 watts), 0.1 Amps nominal (12 watts), fused at 0.4A, 50-60 Hz, 3 wire, Single ϕ</p> <p>Dual State Charger Instruments 90-132 VAC, current draw 0.3 Amps maximum (35 watts), 0.1 Amps nominal (12 watts), fused at 0.5A, 50-60 Hz, 3 wire single ϕ 180-264V AC 0.15 Amps nominal, Fused at 0.315 A, 50-60 Hz, 3 wire, Single ϕ</p>
Battery:	Sealed Lead-acid, 6 VDC, 7.2 Amp-Hr
Operating Temperature Range:	40°F (5°C) to 104°F (40°C)
Operating Humidity Range:	0% to 95% Relative Humidity, non-condensing
Storage/Transport Temperature:	-40°F (-40°C) to 158°F (70°C)
Storage/Transport Humidity:	0% to 95% Relative Humidity, non-condensing

Table 1-2. Performance Specifications

Parameter	Specification
Operating Principle:	Linear Peristaltic
Operating Range:	
Pump and Controller modes:	Integer Keypad/Series V2.xx Software
Rate:	1-999 mL/hr in 1 mL/hr increments (CONTROLLER Mode maximum recommended rate is 500 mL/hr)
Volume-to-be-Infused:	1-9999 mL or ALL (with external ECD)
Keep Vein Open (KVO) Rate:	1 mL/hr
	Fractional/Titration Keypad/Series V5.xx & Subsequent Software
Rate:	<p>MICRO: 0.1-99.9 mL/hr in 0.1 mL/hr increments MACRO: 1-999 mL/hr in 1 mL/hr increments UNIVERSAL: 0.1-99.9 mL/hr in 0.1 mL/hr increments; 100-999 mL/hr in 1 mL/hr increments (CONTROLLER Mode maximum recommended rate is 500 mL/hr)</p>
Volume-to-be-infused:	<p>MICRO: 0.1-999.9 mL in 0.1 mL increments MACRO: 1-9999 mL in 1 mL increments UNIVERSAL: 0.1-999.9 mL in 0.1 mL increments; 1000-9999 mL in 1 mL increments</p>

PC-1

NOTE

In the Universal mode the Rate parameter determines whether the instrument will operate with fractional or integer values.

When selecting VersaTaper, the instrument will be configured for either Micro or Macro parameters depending on rate value programmed for Step 01.

Keep Vein Open (KVO) rate:	1 mL/hr if delivery rate is ≥ 1 mL/hr, or set delivery rate if < 1.0 mL/hr.
Occlusion Pressure:	
Controller Mode:	± 12 inches (30.48 cm) from nominal bottle height
Pump Mode:	10 \pm 2 psi (69 \pm 14 kPa; 517 \pm 103 mmHg). At delivery Rates below 30 mL/hr, occlusion pressure is time dependent to ensure rapid response to occlusion conditions. <u>Software Release V5.59, V6.xx and Subsequent</u> 10 psi mode - occlusion pressure is 10 \pm 2 psi for all rates. <u>Software Release v8.13 only</u> 517 mmHg mode - occlusion pressure is 517 \pm 103 mmHg for all rates.
Air-In-Line Detection:	Dual Mode Ultrasonic (nominal 75 μ L - single boli; 1 ml within 15 minutes - accumulated air) <u>Software Release v8.xx</u> Accumulated air-in-line detection of 1 ml in any 15 min interval.
Secondary (Piggyback):	Dual rate programmable
Communications Data Port:	EIA Standard RS-232-C. Requires standard 9 pin subminiature D connector
Visual Messages:	
PROMPTS:	SELECT P/C MODE, PRESS START, SET RATE and SET VTBI
ADVISORIES:	PRIMARY, SECONDARY, MAINTENANCE [V2.XX/V5.XX/V6.XX], DIAGNOSTIC [V7.XX/V8.XX], PAUSE, INFUSION COMPLETE-KVO, LOW FLOW, EMPTY CONTAINER-KVO (All except PC-1CE v8.xx 220V), LOW BATTERY, TOTAL VOL INFUSED and SEC VOL INFUSED <u>Fractional Keypad/Series V5.xx & Subsequent Software</u> Additional Advisories: MICRO, MACRO, VERSATAPER: SETUP, STEP:xx, STEPS:xx, TOTAL VOL:xxxx, DURATION:hh:mm, VERSATAPER, and TIME LEFT:hh:mm.

Software Release V6.xx and Subsequent
10 psi

Software Release V6.3x and Subsequent
LOW BATTERY...

Software Release v8.13 only
517 mmHg

ALARMS: CHECK ECD (All except PC-1CE v8.xx 220V), CHECK IV SET, CLOSE DOOR, AIR IN LINE, OCCLUDED, "FLO-STOP" OPEN / CLOSE DOOR, OCCLUDED-PATIENT SIDE, OCCLUDED-FLUID SIDE, PARTIAL OCCLUSION-FLUID SIDE, KVO COMM CABL, KVO COMM TOUT and KVO, ACCUMULATED AIL (V8.xx)

MALFUNCTIONS: HELP BATTERY, HELP INTERNAL ERROR and (WATCHDOG)

Delivery Mode/Operating Indicator: Flashes 500 msec on, 500 msec off when instrument is infusing

Battery Operation: 5 hours to HELP BATTERY condition with a new, fully charged battery and the instrument operating at 125 mL/hr. Battery capacity will diminish over time dependent on usage.

Battery Charging-

Instruments without Dual State Chargers

Instrument - Off: 4 hours will recharge a new battery to battery operation specification level (=90% capacity)

Instrument operating at 125 mL/hr: 18 hours recharge will restore a new battery to a fully charged condition

NOTE

To maximize battery life, recharge battery for 10 hours with the power off or 24 hours with the power on between consecutive battery operations.

Instruments with Dual State Charger

Instrument Off or Operating at 125 mL/hr: 4 hours will recharge a new battery to battery operation specification level (=90% capacity)

10 hours recharge will restore a new battery to a fully charged condition

NOTE

Failure to fully recharge the battery between consecutive battery operations will reduce battery life.

Audio Characteristics:

PC-1



AUDIO TYPE	AUDIO PERIOD	VOLUME VAR/FIXED	SILENCE YES/NO
(1) MALFUNCTION v2.xx/5.xx/6.xx	 CONSTANT TONE	ON OFF MAXIMUM	
v7.xx	 600 msec ON, 0.5 sec OFF 600 msec ON, 3 sec OFF	ON OFF 75db FIXED	NO
(2) KEY CLICK	 90 msec ON (Once)	ON OFF VARIABLE	YES
(3) ALARM v2.xx/5.xx/6.xx	 600 msec ON, 3 sec OFF	ON OFF VARIABLE	YES
v7.xx	 600 msec ON, 1.5 sec OFF	ON OFF	
(4) PROMPT	 100 msec ON, 2 sec OFF	ON OFF VARIABLE	YES
(5) ADVISORY	 100 msec ON, 15 sec OFF	ON OFF VARIABLE	YES
(6) CHANGEOVER	 100 msec ON, 400 msec OFF (6 beeps)	ON OFF VARIABLE	NO (v2.xx) YES (v3.xx)

Figure 1-2. Audio Characteristics

Table 1-3. Administration Sets

Model	Description
2110	GEMINI 20 Vented/Nonvented Administration Set with 2 VersaSafe® injection sites, 20 drops/mL
2120	GEMINI 20 Vented/Nonvented Administration Set with Check Valve and 2 VersaSafe injection sites, 20 drops/mL
2126	GEMINI 20 Vented/Nonvented Administration Set with Check Valve and 3 VersaSafe injection sites, 20 drops/mL
2130	GEMINI 20 Vented/Nonvented Administration Set with Check Valve, XL® 0.2 micron filter and 2 VersaSafe injection sites, 20 drops/mL
2140	GEMINI 20 Vented/Nonvented Administration Set with Metered Chamber and 3 VersaSafe injection sites, 20 drops/mL
2141	GEMINI 60 Vented/Nonvented Administration Set with Metered Chamber and 3 VersaSafe injection sites, 60 drops/mL
2177	GEMINI 12 Vented/Nonvented Y-type Blood/Solution Administration Set with 1 VersaSafe injection site, 12 drops/mL
2200	GEMINI 20 Vented/Nonvented Primary, 20 drops/mL
2210	GEMINI 20 Vented/Nonvented Primary with 2 injection sites, 20 drops/mL
2211	GEMINI 60 Vented/Nonvented Primary with 2 injection sites, 60 drops/mL
2214	GEMINI 20 Vented/Nonvented Primary with 15 micron filter, 2 injection sites, 20 drops/mL and multi-language labeling
2220	GEMINI 20 Vented/Nonvented Administration set with Check Valve and 2 injection sites, 20 drops/mL
2226	GEMINI 20 Vented/Nonvented Administration set with Check Valve and 3 injection sites, 20 drops/mL
2230	GEMINI 20 Vented/Nonvented Administration set with Check Valve, 0.2 micron filter and 2 injection sites, 20 drops/mL
2240	GEMINI 20 Vented/Nonvented metered chamber with 3 injection sites, 20 drops/mL
2241	GEMINI 60 Vented/Nonvented metered chamber with 3 injection sites, 60 drops/mL
2255	GEMINI Vented/Nonvented Complimentary Short Set for use with #2906 Manifold
2260	GEMINI 20 Vented/Nonvented Primary for Nitroglycerin and Fat Emulsions, 20 drops/mL
2264	GEMINI 20 Vented Primary with 0.2 micron filter for use with Taxol, 20 drops/mL
2277	GEMINI 12 Nonvented Y-Type for Blood/Solution, 12 drops/mL
2280	GEMINI Primary Syringe Administration Set
2906	GEMINI 20 Vented/Nonvented Administration Set with Manifold below the instrument, 20 drops/mL

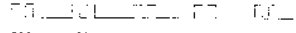
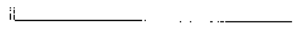
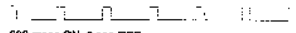
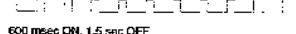
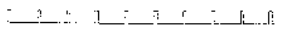
Table 1-4. Accessories

Part No.	Description
1303	Communications Test Plug
1308	Empty Container Detector (for use with Non-Universal spike sets) (110V and 220V) prior to software v8.xx)
2285	Syringe Holder

PC-1

THIS PAGE INTENTIONALLY LEFT BLANK

SECTION 2 - PREPARATION FOR USE

2.1 INTRODUCTION

This section contains information relative to the initial inspection and pre-operational checkout of the IMED GEMINI PC-1 Volumetric Infusion Pump/Controller. These procedures include a mechanical inspection, electrical inspection, pre-operational battery charge and a performance check to ensure that the instrument operates properly and has not been damaged during shipment or storage. The PC-1 pump/controller's operating features are identified in Figure 2-1.

2.2 PRE-OPERATIONAL MECHANICAL INSPECTION

The PC-1 pump/controller has undergone thorough production control and quality assurance testing prior to shipment from the factory. The shipping container has been designed to protect the instrument against damage under normal shipping conditions; nevertheless, internal physical and/or electronic component damage could have occurred without leaving a visible signature. Therefore, it is recommended that the following inspection procedure be performed upon receipt of the instrument at the user's facility.

1. Carefully remove the PC-1 pump/controller from the shipping container. (It is recommended the shipping material be saved in the event the instrument has been damaged and must be returned to the factory for service or repair).
2. Inspect the exterior case, front and rear, for holes, cracks, scratches, spalling, broken or damaged controls, missing components and/or screws.
3. Inspect the amber and green tinted Lexan® windows covering the indicator displays for scratches or cracks.
4. Ensure the pumping chamber access door fits flush with the case at the top, bottom, and sides.
5. Check the door handle/cam lock for ease of operation and flush fit with door when latched.
6. Inspect the pumping mechanism seal for damage and to ensure they are properly attached to the front case.
7. Inspect the air-in-line sensor and Flo-Stop recess for damage or obstructions.
8. Install an approved IMED GEMINI administration set to ensure the Flo-Stop assembly seats correctly and the door closes and latches properly.
9. Actuate each of the keypad controls on the front panel and the audio volume control potentiometer on the rear panel to ensure proper operation (see Figure 3-1 for location of controls).
10. Inspect the power cord for damage, bent prongs or deformed connector.
11. Exercise the pole clamp mechanism to ensure freedom of movement.
12. **220V only.** Inspect AC Power Input Module for proper number and type of fuses, and unrestricted operation of the Power Interrupt switch (where applicable) as well as for physical damage and/or missing parts.
13. **220V only.** Inspect Equipotentiality Ground Point for damage and security.

NOTE

In the event the PC-1 pump/controller shows evidence of shipping damage, notify the carrier's agent immediately. Do not return a damaged instrument to the factory before the carrier's agent has authorized repairs. Contact IMED for authorization to return the instrument for repair regardless of liability for repair costs.

PC-1

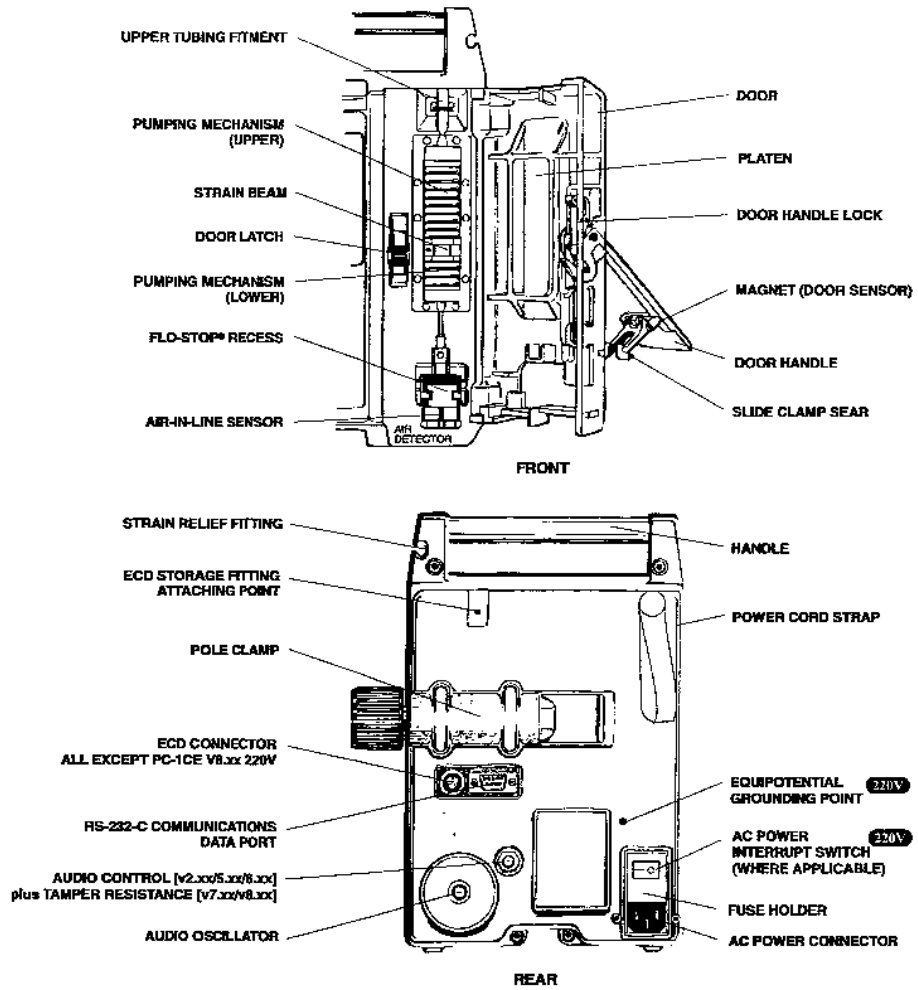

Figure 2-1. PC-1 Front and Rear Operating Features

2.3 OPERATIONAL PERFORMANCE CHECK

Prior to the first operational use and following any routine maintenance or servicing of the PC-1 pump/controller, it is strongly recommended that an operational performance check be performed. The operational performance check consists of two phases; a Pre-operational Electrical Inspection to check the electrical integrity of the instrument for compliance with regulatory agency requirements and an Operational Performance Test to verify proper pump/controller operation.

2.3.1 Pre-operational Check Battery Charge

The battery is fully charged upon completion of the post manufacturing quality assurance inspection. However, since considerable time could elapse between manufacture and first use, a pre-operational battery charge is recommended. Connect the AC power cord to an AC outlet and allow the battery to charge for 24 hours.

2.3.2 Pre-operational Electrical Inspection

The pre-operational electrical inspection includes an electrical leakage test and a ground continuity check.

CAUTION

Some of these tests are inherently hazardous. Safeguards for personnel and property should be employed when conducting such tests. Tests should only be performed by qualified personnel.

2.3.2.1 Electrical Leakage Test

Perform an electrical leakage current measurement in compliance with Underwriters Laboratories (UL) 544 for Patient Care Equipment and/or Canadian Standards Association (CSA) Standard C22.2 No. 125 for Risk Class 2G Equipment. Leakage currents are to be less than 100 microamperes.

2.3.2.2 Electrical Ground Test

Perform an electrical ground impedance measurement in compliance with UL 544 for Patient Care Equipment and/or CSA Standard C22.2 No. 125 for Risk Class 2G Equipment. The impedance between the grounding pin on the power cord plug and the grounding point on the rear case should not exceed 100 milliohms.

2.3.3 Abbreviated Operational Performance Test

The following operational performance test is designed to ensure each of the PC-1 pump/controller's controls and indicators is functioning properly, and to check the operability of all the features available in the normal operating modes.

2.3.3.1 Test Requirements

The following items of laboratory equipment and supplies are required to conduct the operational performance tests:

1. A GEMINI administration set with an upper injection site. (Example: 2210)
2. IV Solution Container.
3. Standard IV Pole.
4. Communications Emulator plug (see Figure 2-2) [if communications option is installed].
5. Hemostat.
6. Empty fluid container.
7. Air-in-line simulator (see Figure 2-3).
8. All except PC-1CE V8.xx 220V. Empty Container Detector "A" [use with Integer or Fractional Keypad PC-1s without ALARIS Medical P/N 1310-1904-1 Installed] or Universal ECD [use with Titration Keypad and Integer or Fractional Keypad PC-1s with ALARIS Medical P/N 1310-1904-1 installed].
9. Pressure gauge of at least 0-20 psig capability.

PC-1

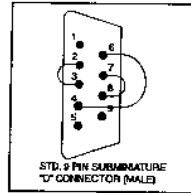

Figure 2-2. Communications Emulator Plug

2.3.3.2 Test Procedures

The following tests and associated procedures are presented in a sequence that provides an efficient, qualitative check of instrument operability.

INITIAL SETUP

1. Mount pump on IV pole (leave AC power cord unplugged).
2. Fill IV fluid container with water and hang on IV pole 24" (61 cm) above PC-1 pump/controller.
3. Spike and prime administration set.
4. If available, attach ECD sensor to the set drip chamber (do not connect to ECD receptacle until instructed).
5. Press POWER ON Control and check:
 - Battery Operation Indicator - Illuminated.
 - RATE and VTBI displays show ("888.8").
 - All LED indicators illuminate momentarily then extinguish, except the delivery mode/operating indicator for the previously selected delivery mode and either "0" or "0.0" or "- - -" in the units digit of Rate and VTBI displays.
 - "PC-1 Vx.xx" message scrolls once across the Status/Alarm Display (x.xx = software version).
 - A single audio Prompt sounds.
 - "SELECT P/C MODE" message scrolls once (if the P/C Mode select is unlocked) followed by continuous scroll of the "SET RATE" message. After 12 seconds the Prompt audio sounds.

Titration Keypad/Series v7.xx & subsequent Software

6. Press and hold the VOL INF control, then press POWER ON and check:
 - Battery Operation Indicator - Illuminated.
 - RATE and VTBI Displays show "888.8" momentarily then extinguish.
 - All LED indicators and dot-matrix elements illuminate momentarily then extinguish.
 - A single audio Prompt is sounded.
 - "setup PC-1 V7.xx (and subsequent) press setup control" scrolls continuously. (7.xx and subsequent) = installed software version).
7. Check or set instrument configuration:
 - a. Press VOL INF control - "tamper-resistant mode" scrolls continuously
 - Press START - "enabled" or "disabled" displays statically.
 - Use either the or control to select "disabled" setting.
 - b. Press VOL INF control - "P/C mode" scrolls continuously
 - Press START - "locked" or "unlocked" displays statically on the Operator Information display.
 - Selected Delivery mode/operating indicator illuminates.
 - Use either the or control to select "unlocked" setting.
 - c. Press VOL INF control - "10 psi mode" or "517 mmHg mode" (v8.13 only) scrolls continuously
 - Press START - "enabled" or "disabled" displays statically.
 - Use either the or control to select "disabled" setting.
 - d. Press VOL INF control - "macro/micro mode" scrolls continuously
 - Press START - "macro", "micro" or "mic/mac" displays statically.
 - Use either the or control to select "mic/mac".
 - e. Press VOL INF control - "Primary switchover alert mode" scrolls continuously
 - Press START - "enabled" or "disabled" displays statically.
 - Use either the or controls to select "enabled".

- f. Press VOL INF control - "communications setup" scrolls continuously
 - Press START - "serial #" displays statically.
 - Use 1, 10, 100 and/or CLEAR/SILENCE controls to input serial number.
 - Press PAUSE/STOP - "baudrate" displays statically.
 - Use either the or control to select baudrate (110, 300, 600, 1200, 2400, 4800 or 9600).
 - Press PAUSE/STOP - "parity" displays statically.
 - Use either the or control to select parity option (O [odd], E [even] or OFF)
 - Press PAUSE/STOP - "stopbits" displays statically.
 - Use either the or controls to select stop bit option (1 or 2).
- g. Press VOL INF control - "language selection" scrolls continuously
 - Press START - currently selected language displays statically.
 - Use either the or control to select language option (english, german, french, italian, swedish, spanish).
- h. Press VOL INF control "exit setup" scrolls continuously.
- i. Press START to exit setup and enter infusion Setup and Operation mode
 - Battery operation LED flashes
 - Rate and VTBI displays show " . . . "

CHARGING INDICATION (with PC-1 turned on)

1. Connect AC Power cord to a 120 or 220 VAC power source and check:
 - AC Power Indicator - illuminates.
 - Battery Operation Indicator - extinguishes.
2. Unplug AC Power cord from the AC power source and check:
 - AC Power Indicator - extinguishes.
 - Six pulses of the audio Alarm - sound [v2.xx/5.xx/6.xx up to 6.55 ONLY].
 - Battery operation indicator - illuminates [v2.xx/5.xx/6.xx up to 6.55 ONLY] - flashes [v6.55/v7.xx and subsequent].
3. Reconnect the AC Power cord to the AC power source.

NORMAL MODE OCCLUSION TESTS

1. Open the access door and check that the pumping mechanism homes.
 2. Install the prepared GEMINI set and close the door. Ensure that the fluid level in the container is 24" above the height of the strain beam.
- #### CONTROLLER MODE
3. Press the P/C MODE control to select Controller mode:
 - Controller mode delivery mode/operating indicator illuminates.
 4. Press RATE control and check:
 - Last confirmed rate or "0" flashes in the rate display.
 - "SET RATE" scrolls continuously.
 5. Use data entry controls to set rate to 125 mL/hr.
 - New rate flashes in rate display.
 - "SET VTBI" scrolls continuously.
 6. Press VTBI control and check:
 - Last confirmed VTBI or "0" flashes in the VTBI display.
 7. Use data entry controls to set VTBI to 50 mL.
 8. Press START control and check:
 - Pumping mechanism operates.
 - Controller mode operating indicator flashes.
 - VTBI value decrements =2 mL/minute.
 9. Use the hemostat to pinch off the tubing above the instrument and check for one of the following conditions (response is dependent upon microprocessor timing sequence):
 - "LOW FLOW" advisory - scrolls
 - Audio advisory - sounds
 - Pumping mechanism - stops
 - or
 - "OCCLUDED" alarm scrolls
 - Alarm audio - sounds
 - Pumping mechanism - stops
 10. Clear occlusion (remove hemostat), open door and allow pump to "home", close door and press START, then check:
 - Pumping mechanism - operates.
 - Operating indicator - flashes.
 - Alarm audio - silences.

PC-1

11. Use hemostat to close off distal tubing and check:
 - "LOW FLOW" advisory scrolls
 - Advisory audio - sounds
 - Pumping mechanism - stops.
12. Within 45 seconds after "LOW FLOW" advisory begins, clear occlusion (remove hemostat) and verify:
 - Pumping mechanism - operates
 - Operating indicator - flashes.

PUMP MODE

13. Press P/C MODE control and change delivery mode to Pump:
 - Pump mode operating LED - illuminates.
14. Press START control and check:
 - Pump mode operating indicator - flashes.
15. Use the hemostat to close off the proximal tubing and check:
 - "OCCLUDED-FLUID SIDE" alarm - scrolls
 - Pump mode ALARM indicator - flashes
 - Alarm audio - sounds
 - Pumping mechanism - stops.
16. Clear occlusion (remove hemostat), then press START and check:
 - Pumping mechanism - operates
 - Operating indicator - flashes.
17. Use the hemostat to close off the distal tubing and check:
 - "OCCLUDED-PATIENT SIDE" alarm - scrolls
 - Pump mode ALARM indicator - flashes
 - Alarm audio - sounds
 - Pumping mechanism - stops.
18. Clear occlusion (remove hemostat), then press START and check:
 - Pumping mechanism - operates
 - Operating indicator - flashes.
19. Remove the set installed in step 2 under NORMAL MODE TESTS.
20. Install the fluid filled air-in-line simulator in the pump. Press syringe plunger to ensure the fluid level is above the air-in-line detector. Close the door and press START. Pump will operate normally, then extract plunger until air is in the air-in-line detector and check:

- "AIR IN LINE" alarm - scrolls
- Pump mode ALARM indicator - flashes
- Alarm audio - sounds
- Pumping mechanism - stops.

21. Upon test completion, remove the air-in-line simulator and re-install set removed in step 2.

PUMP PRESSURE TEST

1. Power down the PC-1 pump/controller and re-initialize instrument in the Maintenance/Diagnostic Mode. Press and hold the COMPUTER CONTROL/MONITOR switch. Then press POWER ON.
2. Connect the distal tubing to the pressure gauge.
3. Press COMPUTER CONTROL/MONITOR switch to select "pump test".
4. Press START control twice.
5. Verify rate set to 125 mL/hr and VTBI >25 mL.
6. Press START control and allow the pump to operate for at least 30 seconds and wait until the peak pressure stabilizes.
7. Record the highest pressure reading obtained. **Resultant pressure must be ≥ 17 psi.**

Software Release V6.xx Instruments & subsequent COMMUNICATIONS

1. Connect the Communications Emulator Plug to the RS-232-C Data Port.
2. Initialize the PC-1 pump/controller in the Maintenance/Diagnostic Mode (see Section 5 for procedure).
 - "Maintenance Vx.xx" or "Diagnostic Vx.xx and subsequent", and "To Exit Press STOP" messages scroll. (x.xx = installed software release).
3. Press COMPUTER CONTROL/MONITOR control 6 times and check:
 - "serial port test" message scrolls continuously.
4. Press START control and check:
 - "echo" message displays statically

or

- " ◀ ◀ " - displays statically in the operator information display and "PLUG" appears in the VTBI display.
5. Press COMPUTER CONTROL/MONITOR control twice to return to the "Maintenance Vx.xx" [v2.xx/5.xx/6.xx] or "Diagnostic Vx.xx" [v7.xx and subsequent] message.
 6. Press PAUSE/STOP control to exit the Maintenance Mode and power down the instrument.
 7. Remove the Communications Emulator Plug from the RS-232-C Data Port.

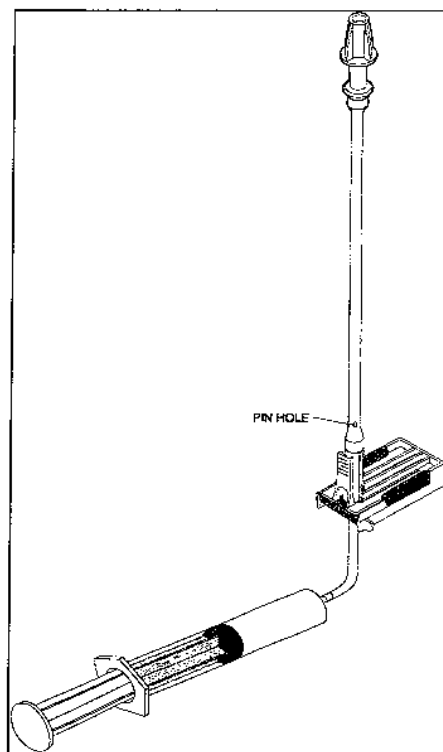

Figure 2-3. Air-In-Line Simulator

PC-1 PUMP/CONTROLLER TEST DATA SHEET

Instrument Serial No. _____ Software Version _____

Date _____ Technician _____

Test No.	Description	Reference	Record Result	Pass/Fail
1	Electrical Leakage Test	2.3.2.1	_____	Pass___/Fail__
2	Electrical Ground Test	2.3.2.2	_____	Pass___/Fail__
3	Initialization	2.3.3.2	_____	Pass___/Fail__
4	Keypad and Display Check	2.3.3.2	_____	Pass___/Fail__
5	Controller Mode Operation	2.3.3.2	_____	Pass___/Fail__
	Slide Clamp Detector	2.3.3.2	_____	Pass___/Fail__
6	Pump Mode Operation	2.3.3.2	_____	Pass___/Fail__
	Air-In-Line	2.3.3.2	_____	Pass___/Fail__

Figure 2-4. PC-1 Pump/Controller Test Data Sheet

PC-1

THIS PAGE INTENTIONALLY LEFT BLANK

SECTION 3 - OPERATION

3.1 INTRODUCTION

This section describes the recommended procedures for operation of the IMED GEMINI Model PC-1 Volumetric Infusion Pump/Controller. The information is intended to provide maintenance technicians with a basic understanding of instrument operation including the audio and visual status/alarm system.

NOTE

Although the PC-1 pump/controller is built and tested to exacting specifications, it is not intended to replace the role of medical personnel in the supervision of IV infusions. The user is urged to exercise vigilance in the utilization of the PC-1 pump/controller.

3.2 CONTROLS AND INDICATORS

The keypad controls and indicators used to set up and operate the PC-1 pump/controller are illustrated in Figures 3-1, 3-1a and 3-2. The functional descriptions of the controls and indicators are listed in Table 3-1.

PC-1

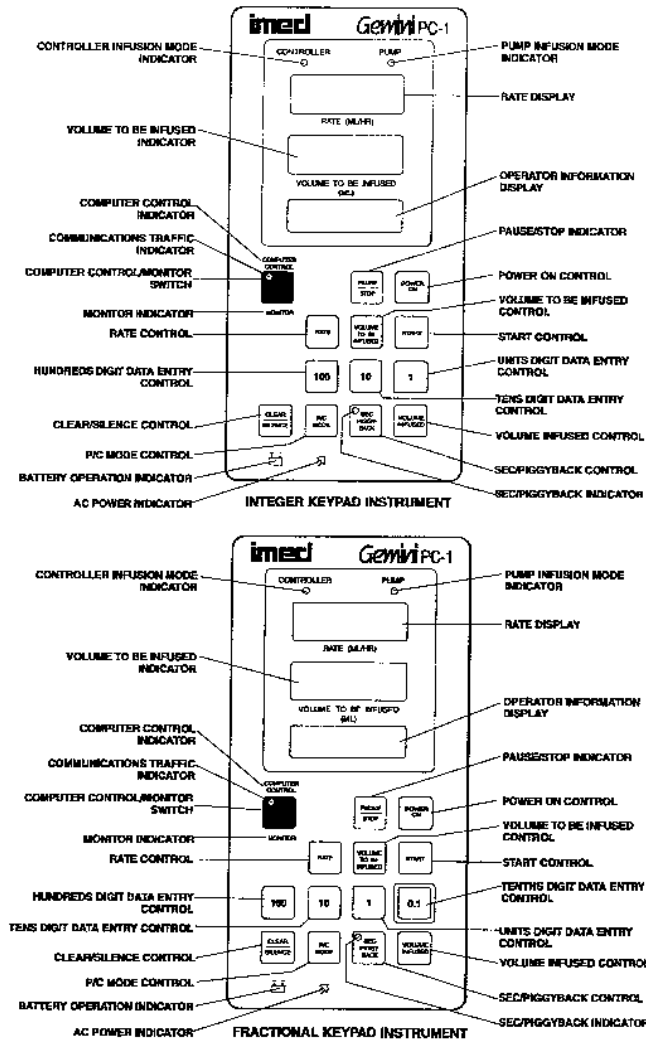

Figure 3-1. PC-1 Pump/Controller Front Panel Controls and indicators

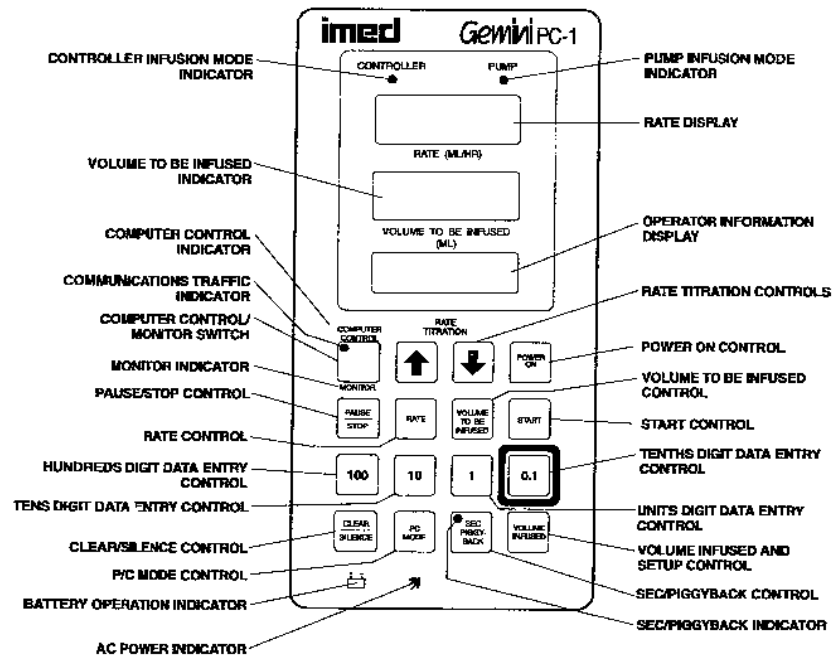

Figure 3-1a. PC-1 Pump/Controller Titration Front Panel Controls and Indicators

PC-1

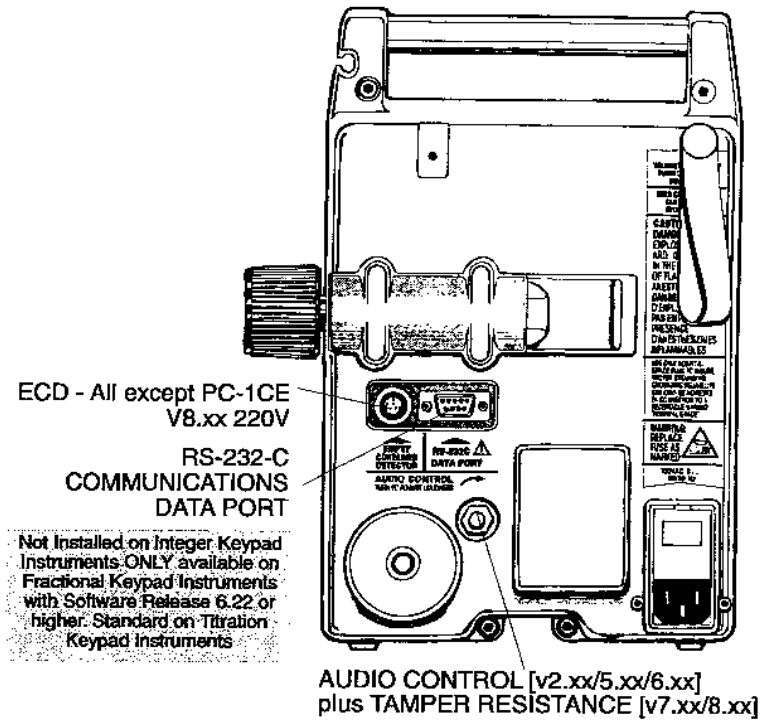

Figure 3-2. PC-1 Pump/Controller Rear Panel Controls and Indicators

Table 3-1. PC-1 Pump/Controller Controls and Indicators

Control/Indicator	Functional Description
FRONT PANEL	
CONTROLLER Delivery Mode/Operating Indicator	LED indicator. LED illuminates when power is on and the Controller delivery mode selected. When infusing, LED flashes to indicate instrument is operating.
PUMP Delivery Mode/Operating Indicator	LED indicator. LED illuminates when power is on and the Pump delivery mode selected. The Versataper function is active when in Pump delivery mode. When infusing, LED flashes to indicate the instrument is operating.
RATE Display	Four digit, 7-segment plus decimal LED Displays. Displays rate infusion parameter for selected operating state (Primary or Secondary). Following initialization "0" or "0.0" or "- - -" displays. Display flashes last confirmed rate when RATE control is actuated. Display changes to steady when Rate value is confirmed by subsequent keypad action.
Volume to be Infused (VTBI) Display	Four digit, 7-segment plus decimal LED displays. Displays VTBI infusion parameter for selected operating state (Primary or Secondary). Following initialization "0" or "0.0" or "- - -" displays. Display flashes last confirmed VTBI when VTBI Control is actuated. Display changes to steady when VTBI value is confirmed. Flashes Total Volume Infused for ≈6 seconds following a single actuation of the VOLUME INFUSED and Secondary Volume infused when VOLUME INFUSED is pressed twice.
Operator Information (Status/Alarm) Display	Eight position dot-matrix display. Scrolls PROMPT, ADVISORY, ALARM and MALFUNCTION messages during Normal operation. Presents scrolled and/or static Maintenance mode test selections, conditions and status reports.
COMPUTER CONTROL Indicator	Backlighted indicator. Flashes when the PC-1 pump/controller is enabled for computer control operation. Illuminates steadily when PC-1/host computer communication is confirmed.
COMPUTER CONTROL/MONITOR Switch	Alternate action type switch. When pressed, selects either Monitor or Computer Control operating condition. Operable only when the computer interface cable is connected. Used in conjunction with POWER ON to initialize the instrument in the Maintenance/Diagnostic Mode and to sequence through the maintenance mode test loop.
MONITOR Indicator	Backlighted indicator. Illuminates when the communication interface cable is connected to the RS-232-C Communications Data Port.
Communications Traffic Indicator	LED indicator. Flashes when communications traffic through the RS-232-C data link is active. Operable only during Monitor and Computer Control operation.

PC-1

Table 3-1 (cont.). PC-1 Pump/Controller Controls and Indicators

Control/Indicator	Functional Description
PAUSE/STOP Control	<p>Momentary contact type switch. When actuated once, puts the instrument into the Pause condition. If infusing, pumping will stop. After 2 minutes in Pause, the "PRESS START" visual and audio prompt will initiate. Second actuation shuts down the instrument.</p> <p>Fractional Keypad/Series V5.xx & Subsequent Software When pressed while in the VersaTaper Setup mode, enters all programmed VersaTaper parameters and initiates the scrolling of the VersaTaper setup summary message.</p>
RATE Control	<p>Momentary contact type switch. When pressed, enables entry, change or clearing of the rate infusion parameter.</p> <p>Fractional Keypad/Series V5.xx & Subsequent Software When pressed while in the VersaTaper mode, causes display to sequence through the programmed steps to review programmed parameters.</p>
VOLUME TO BE INFUSED (VTBI) Control	<p>Momentary contact type switch. When pressed, enables entry, change or clearing of the VTBI infusion parameter.</p> <p>Fractional Keypad/Series V5.xx & Subsequent Software When pressed in conjunction with the POWER ON control, initializes the instrument in VersaTaper: Setup mode.</p> <p>Titration Keypad/Series v7.xx & Subsequent Software When pressed in conjunction with the POWER ON control, initializes the instrument in VersaTaper: Setup (includes AutoTaper and AutoTaper Patient) mode.</p>
RATE TITRATION Controls	<p>Titration Keypad/Series V7.xx & Subsequent Software Momentary contact-type switches. When pressed, will increase or decrease the rate parameter 1 mL/hr (MACRO) or 0.1 mL/hr (MICRO) with each keypress, or will scroll the rate up or down when pressed and held.</p>
START Control	<p>Momentary contact type switch. When pressed, starts the pumping mechanism.</p> <p>Fractional Keypad/Series V5.xx & Subsequent Software When pressed while in VersaTaper: Setup mode, advances the displayed step to the next step.</p>
POWER ON Control	<p>Momentary contact type switch. When pressed, applies electrical power to the PC-1 pump/controller. In the event of a hardware malfunction, identified by continuous audio, actuating POWER ON will remove electrical power from all circuits not connected to +5V_(PBC1) (and silence malfunction audio).</p>

Table 3-1 (cont.). PC-1 Pump/Controller Controls and Indicators

Control/Indicator	Functional Description
CLEAR/SILENCE Control	<p>Momentary contact type switch. When pressed subsequent to actuating the RATE, VTBI or VOLUME INFUSED controls, clears the corresponding display for the selected channel. When pressed, while Alarm or Prompt audio is sounding, will temporarily silence the audio for 2 minutes; when internal instrument protocol permits.</p> <p><u>Fractional Keypad/Series V5.xx & Subsequent Software</u> When pressed in conjunction with the POWER ON control, will return the instrument to normal (non-VersaTaper and AutoTaper) operation.</p>
Hundreds & Thousands (100) Digit Data Entry Control	<p>Momentary contact type switch. Single actuation subsequent to actuating the RATE or VTBI controls increments the hundreds digit of the corresponding display. When pressed and held, allows the hundreds digit to increment automatically. The hundreds digit upon reaching 9 rolls over to 0 and increments the thousands digit by 1.</p> <p><u>Fractional Keypad/Series V5.xx & Subsequent Software</u> When pressed in conjunction with the POWER ON control, will initialize the instrument in the MACRO mode or toggle mode to UNIVERSAL if previously in MACRO mode.</p>
Tens (10) Digit Data Entry Control	<p>Momentary contact type switch. When pressed subsequent to actuation of the RATE or VTBI control, increments the tens digit of the corresponding display. Display rolls over 9 to 0.</p> <p><u>Fractional Keypads/Series V6.xx and Subsequent</u> When pressed in conjunction with the POWER ON control, invokes the 10 psi occlusion pressure lock feature.</p> <p><u>Software Release v8.13 only</u> When pressed in conjunction with the POWER ON control, invokes the 517 mmHg occlusion pressure lock feature.</p>
Units (1) Digit Data Entry Control	<p>Momentary contact type switch. When pressed subsequent to actuation of the RATE or VTBI control, increments the units digit of the corresponding display. Display rolls over 9 to 0.</p>
Tenths (0.1) Digit Data Entry Control	<p><u>Fractional Keypad/Series V5.xx and Subsequent Software</u> Momentary contact type switch. When pressed subsequent to actuation of the RATE or VTBI control, increments the tenths digit of the corresponding display. Display rolls over from 0.9 to 0.0. When pressed in conjunction with the POWER ON control, initializes the instrument in the MICRO mode or toggles mode to UNIVERSAL if previously in MICRO mode.</p>

PC-1

Table 3-1 (cont.). PC-1 Pump/Controller Controls and Indicators

Control/Indicator	Functional Description
Battery Operation Indicator	Backlighted indicator. Illuminates steadily when the PC-1 pump/controller is operating on battery power [v2.xx through 5.18]. Flashes when PC-1 pump/controller is operating on battery power [v5.59 and subsequent].
P/C (Delivery) MODE Control	Alternate action type switch. When pressed, changes the delivery mode between Pump and Controller. When pressed in conjunction with the POWER ON control invokes the P/C Mode lockout feature. Fractional Keypad/Series V5.xx & Subsequent Software When pressed in conjunction with the START control while in the VersaTaper mode, initiates a VersaTaper infusion.
SEC/PIGGYBACK Control	Alternate action type switch. When pressed, enables the instrument in the Secondary state allowing Secondary infusion parameters to be programmed and a Secondary infusion to be initiated.
Sec/Piggyback Indicator	LED indicator. Flashes when the instrument is in the Secondary state. Illuminates steadily when the instrument is performing a secondary infusion.
VOLUME INFUSED Control	Momentary contact type switch. When actuated, causes the Total Volume Infused value to flash for 6 seconds on the VTBI display and scroll the "TOTAL VOL INFUSED" message once. When pressed twice with the instrument in the Secondary mode, will cause the Secondary Volume Infused to flash for 6 seconds on the VTBI display and scroll "SEC VOL INFUSED" once. Used by Biomedical and other specially trained personnel to access the SETUP mode to configure the instrument for specific operating modes.
AC Power Connected Indicator	Backlighted Indicator. Illuminates when the PC-1 pump/controller is connected to an external AC power source.
REAR PANEL	
<u>Integer/Fractional Keypad Instruments</u>	
AUDIO CONTROL	When rotated, varies audio output volume; when protocol permits.
<u>Titration Keypad Instruments</u>	
AUDIO/TAMPER-RESISTANT CONTROL	Dual action switch/potentiometer. When rotated, varies the audio volume when permitted; when pressed, silences audio alarm for ≈2 minutes. When pressed and held for 3 seconds with the tamper-resistant feature enabled, will lock out all of the keypad controls except VOLUME INFUSED, SEC/PIGGYBACK and CLEAR/SILENCE. A repeat 3 second actuation will unlock the keypad controls.
220V AC Power Interrupt Switch (if installed)	Rocker type switch used to apply and interrupt AC voltage to the instrument for operation of the battery charging and control circuits.

3.3 OPERATING CONDITIONS

The GEMINI PC-1 pump/controller can be operated independently (Normal Operation) or as a computer controlled device (Computer Operation) when the communications option is installed. Normal operation includes the two patient care delivery modes - Pump and Controller plus a Maintenance mode which is provided for use by bio-medical personnel to service the instrument. Computer operation encompasses a Monitor and Computer Control mode. Operating procedures for both normal and computer operation are described in detail in paragraph 3.3.1.1 below. Procedures unique to a specific operating mode are enclosed in a box. Operations that may be performed from the host computer terminal are identified by a (C) in the left margin. Maintenance mode capability is addressed briefly in paragraph 3.3.2 of this section and operating details are provided in paragraph 5.3.2 of Section 5.

3.3.1 Normal and Computer Operation

A tactile keypad and visual displays comprise the user interface. The keypad is used to power up and configure the instrument, to enter and/or change infusion parameters, to start the instrument, and to pause and/or stop instrument operation.

Integer/Fractional Keypad Instruments

Tamper-resistant operation is achieved through the requirement to actuate the appropriate control keys in a prescribed sequence.

Titration Keypad Instruments

Tamper-resistant operation (keypad lockout) is enabled in the SETUP mode and selected/deselected by using the press feature of the Audio Control switch.

3.3.1.1 Pump and Controller Modes

The decision to use the PC-1 instrument in the Pump or Controller delivery mode for specific IV infusions resides with the patient's attending medical personnel. If desired, the PC-1 pump/controller can be locked into either the Pump or Controller mode. The instrument's occlusion pressure sensing is predicated on the delivery mode selected and the head height of the IV solution container. With the recommended 24 inch (61 cm) head height and the instrument operating in the Controller mode, an occlusion will be sensed when the distal tubing in-line pressure exceeds

container height pressure by ± 12 inches (30 cm) of container height. In the Pump mode, occlusion pressure is pre-set to 10 ± 2 psi (69 ± 14 kPa) [IV container height is less critical]. The procedural steps described in the following paragraphs pertain to both normal and computer operating conditions. Procedures unique to a specific operating condition(s) are enclosed in a frame.

Setup and Operating Procedures

1. Connect the PC-1 pump/controller to an external AC power source using the power cord supplied by IMED. It is recommended that the power cord remain plugged into the instrument at all times.

WARNING

Prior to reattaching the AC power cord to the instrument, ensure the male base of the power input module is clean of any electrolyte and thoroughly dry. Check the female contacts on the power cord connector for presence of any electrolyte; if contaminated, replace the power cord.

Monitor and Computer Control Operation

- Ensure the computer communications parameters for the host computer and the PC-1 are set up and the communications interface cable is connected to the RS-232-C Communications Data Port.

- 1a. **(220V)** Turn the AC Power Interrupt switch on (where applicable).
2. Press the POWER ON control and check:
 - All indicators illuminate, all segments of the RATE and VTB! displays illuminate ("888.8"); the Operator Information display remains blank.
 - "PC-1 Vx.xx" scrolls once across the operator information display (x.xx represents the installed software revision).
 - Keyclick audio sounds once.
 - The Delivery Mode/Operating LED illuminates according to the previously selected delivery mode.
 - "SELECT P/C MODE" will scroll once, if the P/C Mode lockout has not been invoked.

PC-1

Integer Keypad/Series V2.xx Software

- Rate and VTBI displays will show a "0" in the units digit display and "SET RATE" prompt begins scrolling. After 12 seconds, Audio Prompt will begin.

Fractional Keypad/Series V5.xx & Sub. Software

- In the Universal or MACRO mode, the Rate and VTBI display will show a "0" in the unit digit display. In MICRO, or UNIVERSAL mode subsequent to a MICRO selection, the Rate and VTBI displays will show "0.0" in the unit and tenths digit displays. "SET RATE" will begin scrolling followed by "MACRO" or "MICRO" as appropriate to the selected mode. After 12 seconds, the Audio Prompt will begin.

Titration Keypad/Series V7.xx & subsequent Software

- Rate and VTBI displays will show "- - -". "SELECT P/C MODE" will scroll once, if not locked; "SET RATE" will begin scrolling followed by "MICRO" or "MACRO", if appropriate. After 12 seconds, the Audio Prompt will begin.

Monitor and Computer Control Operation

- Monitor indicator illuminates

NOTE

After 2 minutes, the PC-1 pump/controller will automatically shutdown unless the instrument is in an alarm condition, a control key is actuated or the COMPUTER CONTROL/MONITOR switch is pressed.

3. Prepare the IV fluid container following accepted hospital procedure.
4. Open the GEMINI administration set package, remove set, and close the roller clamp.
5. Insert the set spike into the fluid container and hang the IV container 24 inches (61 cm) above the instrument following accepted hospital procedure.
6. Fill the drip chamber to approximately (2/3 full).
7. Open the roller clamp slowly to prime and clear all air from the injection sites and tubing fittings.

8. Close the roller clamp.
9. Open the door and insert the upper tubing fitment into the recess above the pump mechanism. Using care to avoid stretching the pumping segment, insert the Flo-Stop fitment into the AIL/SCD recess below the pump mechanism with the arrow pointing into the pump. Press the tubing into the air-in-line detector. Close the door. Follow the specific instructions included with the set.
10. Open the roller clamp.

Computer Control Operation

Press the COMPUTER CONTROL/MONITOR switch:

- The COMPUTER CONTROL indicator flashes
- The MONITOR indicator extinguishes
- When communications are established, the COMPUTER CONTROL indicator will change to steady
- During two-way communications between the PC-1 and host computer, the Communications Traffic indicator will flash.

Enter parameters, initiate and stop the infusion from the host computer using the C2 Communications Protocol operators described in the C2 Programmer's Guide ALARIS Medical Systems P/N 1320-9004.

11. Press the P/C MODE control to set the delivery mode (**selection not available if P/C Mode lockout is invoked**).
 - The appropriate delivery mode indicator illuminates.
12. Set the RATE and VTBI. (C)
 - a. Press the RATE control and check:
 - The last entered rate flashes on the display.
 - The "SET RATE" prompt continues to scroll.

Fractional Keypad/Series V5.xx & Sub. Software

NOTE

In **MACRO** or **UNIVERSAL** mode with rate ≥ 100 mL/hr, the tenths (0.1) control is not functional. In **MICRO** or **UNIVERSAL** mode with the rate in tenths, the hundreds (100) control is not functional. In **UNIVERSAL** mode, pressing **CLEAR/SILENCE** will enable entry of either tenths or hundreds parameters.

- b. Use the data entry controls to set/change rate:
 - The "SET RATE" prompt extinguishes.
 - The new rate flashes on the display.
- c. Press the VTBI control and check:
 - The new rate displays steadily on the display.
 - The last entered VTBI flashes on the display.
 - The "SET VTBI" prompt continues to scroll.

Fractional Keypad/Series V5.xx & Sub. Software

NOTE

In **MACRO** mode, the tenths (0.1) control is not functional. In **UNIVERSAL** mode with Rate set to a fractional value, the VTBI will be confirmed and displayed as a fractional value and will decrement in 0.1 mL increments.

- d. Use the data entry controls to change VTBI:
 - The "SET VTBI" prompt extinguishes.
 - The new VTBI flashes on the display.
 - The "PRESS START" prompt begins scrolling after 5 seconds followed by the audio prompt.

NOTE

All except PC-1 CE V8.xx 220V. A VTBI selection of "ALL" is only available when an Empty Container Detector (ECD) is connected to the instrument.

13. Attach the set to the patient's indwelling venipuncture device following accepted hospital procedure.

14. Press the **START** control. C
 - The delivery mode and infusion parameters are entered.
 - The infusion is started.
 - The VTBI displays steadily on the display.
 - The "PRESS START" prompt extinguishes.
 - The audio prompt silences.
 - The delivery mode/operating indicator flashes.

Verify the delivery mode/operating indicator is flashing. This is the positive indication that the instrument is infusing.

During infusion:

- The VTBI decrements.
- The volume infused increments (not displayed).
- Various Advisories, Alarms, and Malfunctions may be displayed. Refer to the Operator Information Display and Alarm Response Procedures section in this manual for an explanation and appropriate response.

Upon completion of the infusion:

- An audio prompt sounds.
- The "INFUSION COMPLETE-KVO" or the "EMPTY CONTAINER-KVO" advisory, as appropriate, scrolls continuously across the display.
- A KVO infusion is initiated.

Integer Keypad/Series V2.xx Software

KVO rate is 1 mL/hr.

Fractional Keypad/Series V5.xx & Sub. Software

KVO rate is 1 mL/hr for infusion rates ≥ 1 mL/hr or the set rate for rates < 1.0 mL/hr.

- The RATE display shows the KVO rate.
- The delivery mode/operating indicator continues to flash.

NOTE

The following detailed operating procedures apply to all instrument configurations and operation in either the Pump or Controller delivery mode. Procedures that are compatible with Computer Controlled operation are identified with a C and are performed using C2 Communications Protocol Commands and/or Queries (See ALARIS Medical Systems Programmer's Guide for C2 Communications Protocol P/N 1320-9004).

PC-1

Pausing an Infusion



1. Press the PAUSE/STOP control once.
 - The infusion stops.
 - The delivery mode/operating indicator illuminates steadily according to the delivery mode selected.
 - The audio prompt silences (if active).
 - An Advisory audio sounds repeatedly after 15 seconds.
 - The "SET RATE" or "SET VTBI" prompts extinguish.
 - The "PAUSE" advisory continuously scrolls.
 - After 2 minutes, the "PRESS START" prompt begins scrolling, Advisory audio ceases and Prompt audio begins.
2. Press the START control to resume the infusion.
 - The infusion is resumed.
 - The "PAUSE" advisory extinguishes.

Stopping a Primary Infusion



1. Press the PAUSE/STOP control twice.
 - Operator information display shows "OFF n", where "n" represents a count down timer. The display counts down from "3" to "1". After reaching "1", the PC-1 pump/controller powers down.
 - The infusion stops.
 - The delivery mode/operating indicator extinguishes.
 - Rate and VTBI displays go blank.
 - Active messages extinguish.
 - Active audio ceases.

Titrating Rate

1. Repeatedly press the or control to change the rate parameter in 1 or 0.1 mL/hr increments, or press and hold the or control to scroll quickly to a new rate parameter.
 - Rate display will flash the rate as the selection changes.
 - After 5 seconds, the "PRESS START" prompt starts scrolling.
2. Press START.
 - The new rate is entered and displays steadily.
 - The instrument begins to infuse at the new rate.

Changing Rate or VTBI During Infusion



1. Press the RATE control to change rate.
 - The last confirmed rate flashes on the display.
 - After 5 seconds, "SET RATE" message begins scrolling.
2. Use the appropriate data entry controls, or the or controls to change rate.
 - The "SET RATE" message extinguishes.
 - The new rate flashes on the display.
3. Press the VTBI control to change VTBI.
 - The new rate displays steadily.
 - The current decremented VTBI flashes on the display.
 - After 5 seconds, "SET VTBI" message begins scrolling.
4. Use the appropriate data entry controls to change VTBI.
 - The new VTBI flashes on the display.
 - The "SET VTBI" message extinguishes.
5. Press the START control.
 - The new infusion parameters are confirmed.
 - The infusion resumes at the new infusion parameters.
 - The new VTBI displays steadily.

Changing Delivery Mode During Infusion (P/C Mode unlocked)

1. Press the P/C MODE control.
 - The delivery mode/operating indicator illuminates according to the new delivery mode selected.
 - The delivery mode/operating indicator for the previously entered delivery mode continues to flash.
2. Press the START control.
 - The new delivery mode is confirmed.
 - The infusion resumes in the new delivery mode.

Restarting an Infusion Following an "INFUSION COMPLETE-KVO" or "EMPTY CONTAINER-KVO" Advisory

1. Press the P/C MODE control to change delivery mode, if a delivery mode change is desired.

2. Press the RATE control and use data entry controls to change rate.
3. Press the VTBI control and use data entry controls to change VTBI.

Software Release V6.xx and V7.xx

All except PC-1 CE V8.xx 220V. When an ECD is connected, either the Rate or VTBI control must be pressed prior to pressing START to avoid confirming KVO as the new rate.

4. Press the START control.
 - The new infusion parameters are confirmed and displayed.
 - The infusion is started.
 - The "INFUSION COMPLETE-KVO" or "EMPTY CONTAINER-KVO" message extinguishes.

To View Total and/or Secondary Volume Infused 

1. Press the VOLUME INFUSED control once.
 - The Total Volume Infused will flash on the VTBI display for 6 seconds.
 - The "TOTAL VOL INFUSED" message scrolls once.
2. Press the VOLUME INFUSED control twice while the PC-1 pump/controller is in Secondary mode.
 - The Secondary Volume Infused will flash on the VTBI display for 6 seconds.
 - The "SEC VOL INFUSED" message scrolls once.

To Clear Total and Secondary Volume Infused 

1. Press VOLUME INFUSED control.
 - The Total Volume Infused will flash on the VTBI display.
2. Press CLEAR control while Volume Infused display is flashing.
 - The Total and Secondary Volume Infused displays reset to "0".
3. Press START control.

Setting Up Secondary (Piggyback) Infusion With Dual Rates

1. Set up the Primary infusion (using a check valve administration set) as previously described. The Secondary infusion may be set

- up prior to or after starting a Primary infusion.
2. Prepare the Secondary fluid container following accepted hospital procedure.
3. Open the IMED SECONDARY administration set package, remove set, and close clamp.
4. Insert the set spike into the fluid container and hang the Secondary container following accepted hospital procedure.
5. Attach the needle to the Secondary set.
6. Fill the drip chamber at least 2/3 full.
7. Open clamp and prime the set. Close clamp.
8. Insert the Secondary set needle into the upper injection site on the Primary set.
9. Lower the Primary fluid container using the hanger provided with the Secondary set.
10. Open the clamp on the Secondary set.
11. Press the SEC/PIGGYBACK control.
 - Primary infusion continues unabated.
 - The SEC/PIGGYBACK indicator flashes.
 - The RATE and VTBI displays show "SEC".
 - The "SET RATE" message begins scrolling.
12. Press the RATE control.
 - The last confirmed rate flashes.
 - The "SET RATE" message continues to scroll.
 - The "SET VTBI" message begins scrolling.
13. Use the appropriate data entry controls to set or change Secondary rate.
 - The "SET RATE" message is cancelled.
 - The new Secondary rate flashes in the Rate display.
14. Press the VTBI control.
 - The new Rate is confirmed and displays steadily.
 - The last confirmed VTBI flashes.
 - The "SET VTBI" message continues to scroll.
 - The "PRESS START" message begins to scroll.
15. Use the appropriate data entry controls to set or change Secondary VTBI.
 - The "SET VTBI" message is cancelled.
 - The new Secondary VTBI flashes on the

PC-1

- display.
16. Press the START control.
 - The new VTBI is confirmed and displays steadily.
 - The instrument operation changes to the Secondary infusion parameters.
 - The "SECONDARY" message begins continuous scrolling.
 - The SEC/PIGGYBACK indicator illuminates steadily.

NOTE

Verify that the VTBI setting does not exceed the contents of the Secondary fluid container.

During Secondary infusion:

- The Secondary VTBI decrements.
- The Secondary volume infused increments (not visible).

Upon completion of the Secondary infusion:

- The Changeover audio sounds (if enabled).
- The instrument switches over to the Primary infusion parameters.
- The preset Primary rate and VTBI display steadily on the displays.
- The SEC/PIGGYBACK indicator extinguishes.
- The "SECONDARY" message extinguishes.
- The "PRIMARY" message begins scrolling.

NOTE

If the Secondary VTBI parameter is set at a value less than the volume of fluid in the secondary container, there will be fluid remaining in the secondary container when the instrument changes over to primary infusion parameters. This residual fluid will be infused at the primary rate. When the fluid level in the secondary set is at the same level as the fluid in the primary set drip chamber both solutions will infuse simultaneously until the secondary set is empty.

Viewing Primary Infusion Parameters During Secondary Infusion C

- 1 Press SEC/PIGGYBACK control.
 - Primary RATE and VTBI parameters will flash on the respective displays for 6 seconds.

Changing Primary Infusion Parameters During Secondary Infusion C

1. Press the SEC/PIGGYBACK control.
 - The Secondary infusion continues unabated.
 - The SEC/PIGGYBACK indicator flashes.
 - The last confirmed Primary Rate and VTBI flash on the displays.
 - The "SECONDARY" message is suppressed.
 - The "PRIMARY" message scrolls.
2. Press the RATE control and use the data entry controls to change the Primary rate.
 - The "SET RATE" and "PRESS START" messages begin scrolling.
 - Last confirmed VTBI displays steadily.
 - Newly entered Primary rate value flashes.
 - The "SET RATE" message is cancelled and "SET VTBI" begins scrolling.
3. Press the VTBI control and use the data entry controls to change the Primary VTBI setting.
 - The last confirmed Primary VTBI value flashes.
 - The new Rate value displays steadily.
 - Newly entered Primary VTBI value flashes.
 - The "SET VTBI" message is cancelled.
4. Press the SEC/PIGGYBACK control.
 - The new infusion parameters are confirmed.
 - The SEC/PIGGYBACK indicator illuminates steadily.
 - The "SECONDARY" message resumes scrolling.
 - The "PRIMARY" message is cancelled.

Stopping a Secondary Infusion and Returning to Primary Infusion

1. Close Secondary set clamp.
2. Press the SEC/PIGGYBACK control.
3. Press the START control:
 - The Secondary infusion stops.
 - The Primary infusion starts.
 - The Primary rate and VTBI display steadily on the respective displays.
 - Changeover audio sounds (if enabled).

All except PC-1CE V8.xx 220V. Infusing using an Empty Container Detector "A" (ECD)

1. Set up a Primary infusion.
2. Connect an ECD to the PC-1 ECD connector and attach the ECD sensor to the drip chamber of the Primary set.
3. Set the Primary VTBI to "ALL" by clearing the VTBI and pressing the 1 data entry control once.
4. Press the START control. When an empty container is detected:
 - Audio prompt sounds.
 - The "EMPTY CONTAINER-KVO" message scrolls continuously.
 - A KVO infusion is initiated.
 - The RATE display shows the KVO rate.

Clearing Alarms

1. Check the operator information display to determine the alarm condition.
2. Refer to the Operator Information Display and Alarm Response Procedures (Section 3.4) in this manual for the proper procedures for responding to a specific alarm condition.

TURNING OFF THE PC-1 PUMP/CONTROLLER

1. Press the PAUSE/STOP control twice to terminate an infusion.
 - Operator information display shows "OFF n", where "n" represents a count down timer. The display counts down from "5" [v2.xx through v6.xx] or "3" [v7.xx and subsequent] to "1". After reaching "1", the PC-1 pump/controller powers down.
 - The infusion stops.
 - The delivery mode/operating indicator extinguishes.
 - Active messages extinguish.
 - Active audio ceases.
 - Rate and VTBI displays go blank.

NOTE

To interrupt the power down sequence, press PAUSE/STOP control on the keypad. To resume an infusion press START, then ensure the delivery mode/operating indicator is flashing.

Computer Control Operation

- At the instrument, press the COMPUTER CONTROL/MONITOR switch. The Computer Control indicator will extinguish and the MONITOR indicator will illuminate, then proceed as above for non-computer operation.

NOTE

In the event of a hardware-detected malfunction (evidenced by constant audio), the POWER ON control must be pressed to silence the audio and interrupt instrument electrical power. Pressing the POWER ON control a second time will re-power the instrument and allow normal shut down procedures to be employed. If the malfunction can not be circumvented, the instrument will require technical personnel to silence the alarm and deactivate the electrical circuit. In the event of a software-detected malfunction, i.e., a HELP message appearing in the operator information display, the PC-1 pump/controller must be turned off by pressing the PAUSE/STOP control.

Locking and Unlocking the P/C MODE Control

1. To Lock - while depressing the P/C MODE control, press POWER ON to initialize the instrument. The delivery mode previously selected will be locked-in.
2. To Unlock - powerdown the instrument, simultaneously depress the P/C MODE control and press POWER ON to initialize. The P/C MODE control will be restored to normal operation.

**Fractional/Titration Keypad Instruments
Locking and Unlocking the MICRO Delivery Mode**

1. To Lock - With the instrument off, press and hold the tenths (0.1) key then press POWER ON. After initialization, release the tenths key:
 - "MICRO" message will scroll following the "SELECT P/C MODE" message or "PC-1 Vx.xx" if P/C Mode lockout is invoked.
 - "MICRO" message will cancel once the RATE control has been pressed.
 - RATE and VTBI displays will appear in the

PC-1

- "0.0" format.
- To Unlock - With the instrument off, press and hold the tenths (0.1) key then press the POWER ON control. Following initialization, release the tenths key:
 - The instrument is now in UNIVERSAL mode
 - RATE and VTBI displays will appear in either the "0.0" or "0" format depending upon the Universal mode RATE and VTBI parameters selected.

Locking and Unlocking the MACRO Delivery Mode

- To Lock - with the instrument off, press and hold the hundreds (100) key then press POWER ON. Following initialization, release the hundreds key:
 - "MACRO" message will scroll following the "SELECT P/C MODE" message or "PC-1 Vx.xx" if P/C Mode lockout is invoked.
 - "MACRO" message will cancel once the RATE control has been pressed.
 - RATE and VTBI displays will appear in the "0" format.
- To Unlock - with the instrument off, press and hold the hundreds (100) key then press the POWER ON control. Following initialization, release the hundreds key:
 - The instrument is now in UNIVERSAL mode.
 - RATE and VTBI displays will appear in either the "0.0" or "0" format, depending on the RATE and VTBI parameters selected.

Software Release V6.xx and Subsequent

Locking and Unlocking the 10 PSI/517 mmHg mode.

- To Lock - With the instrument off, press and hold the tens (10) key then press POWER ON. After initialization release the tens key:
 - "10 PSI" or "517 mmHg" (v8.13 only) message will scroll until the START control is actuated.
- To Unlock - With the instrument off, press and hold the tens (10) key then press the POWER ON control. Following initialization, release the tens key.

Software Release V7.xx and Subsequent

Software Release v7.xx and subsequent

A feature in the Setup Mode allows Pump mode occlusion pressure to be locked at 10 psi or 517 mmHg (v8.13 only) for all rates.

Hold setup (VOLUME INFUSED) key at power on to enter setup mode.

Instrument SETUP mode

Setup mode defaults	
tamper resistant	disabled
P/C mode	unlocked
10 psi mode or 517 mmHg (v8.13 only)	disabled
macro/micro mode	MIC/MAC
Primary switchover alert mode	enabled
communications setup:	
serial #	0000
baudrate	9600
parity	off
stopbits	1
accumulated Air In Line Section (V8.xx only)	disabled
language selection	english

- Press and hold the SETUP control, then press POWER ON
 - Following self test, "Setup PC-1 V7.xx Press Setup Control" scrolls continuously (7.xx identifies installed software release).
- Press SETUP control - "tamper-resistant mode" scrolls continuously.
 - Press START - "enabled" or "disabled" displays statically.
 - Use the or controls to select either "enabled" or "disabled" setting
- Press SETUP control - "P/C mode" scrolls continuously
 - Press START - "locked" or "unlocked" displays statically on the Operator Information display.
 - Selected Delivery mode indicator illuminates.
 - Use the or controls to toggle between PUMP and CONTROLLER mode.
 - Use the or controls to select either "unlocked" or "locked" setting.
- Press SETUP control - "10 psi mode" or "517 mmHg" (v8.13 only) scrolls continuously
 - Press START - "enabled" or "disabled" displays statically.
 - Use the or controls to select either enabled or disabled setting.
- Press SETUP control - "macro/micro mode" scrolls continuously

- Press START - "macro", "micro" or "MIC/MAC" displays statically.
 - Use the or controls to select either "macro", "micro" or "MIC/MAC".
6. Press SETUP control - "Primary switchover alert mode" scrolls continuously
 - Press START - "enabled" or "disabled" displays statically.
 - Use the or controls to select either "enabled" or "disabled".
 7. Press SETUP control - "communications setup" scrolls continuously
 - Press START - "serial #" displays statically.
 - Use 1, 10, 100 and/or CLEAR/SILENCE controls to input serial number.
 - Press PAUSE/STOP - "baudrate" displays statically.
 - Use the or controls to select baudrate (110, 300, 600, 1200, 2400, 4800 or 9600).
 - Press PAUSE/STOP - "parity" displays statically.
 - Use the or controls to select parity option (O [odd], E [even] or OFF)
 - Press PAUSE/STOP - "stopbits" displays statically.
 - Use the or controls to select stop bit option (1 or 2).
 8. Press SETUP control - "LANGUAGE SELECTION" scrolls continuously
 - Press START - currently selected language displays statically.
 - Use the or controls to select language option (english, german, french, italian, swedish, spanish).
 9. Press SETUP control - "POWERDOWN" scrolls continuously
 - Press START or PAUSE/STOP controls to power down
or
 10. Press SETUP control - "EXIT SETUP" scrolls continuously
 - Press START to exit setup and enter infusion Setup and Operation mode
or
 - Press SETUP control to return to "tamper-resistant mode" option.

NOTE

P/C Mode, MICRO or MACRO and 10 psi/ 517 Hg (v8.13 only) modes can be locked/unlocked independent of the SETUP mode.

3.3.1.2 VersaTaper/AutoTaper Mode Operation

Fractional Keypad/Series v5.xx/6.xx Software

VersaTaper Setup

1. Ensure the PC-1 pump/controller is turned off.
2. Press the POWER ON control while pressing and holding the VTBI control.
3. When initialization is complete, release the VTBI control and check:
 - Following display of the "PC-1 Vx.xx" message, "VERSATAPER: SETUP" will scroll.
 - Delivery mode/operating indicator will illuminate corresponding to the last delivery mode selected.
 - Rate and VTBI displays will show the last confirmed rate and VTBI for VersaTaper Step 01.
 - "MACRO" or "MICRO" will scroll if the instrument is locked in either mode or if Step 01 contains an integer or fractional value respectfully.
 - If the Step 01 rate and VTBI displays show "0", the "SET RATE" message will scroll and audio prompt will sound.
4. Use the P/C MODE control to select the delivery mode (selection not available if P/C Mode lockout is invoked).
5. Press RATE control:
 - "SET RATE" message will scroll
 - Last confirmed rate will flash in rate display.
6. Use data entry controls to program rate for STEP:01
 - Entered rate will flash in rate display.
 - "STEP:01" will display statically on Operator Information display.
7. Press the VTBI control:
 - Last confirmed VTBI value will flash in the VTBI display.
 - If VTBI value=0, "SET VTBI" message will scroll.
8. Use data entry controls to program VTBI for STEP:01.
9. Press the START control:
 - "STEP:02" will display statically on the Operator Information display.

PC-1

10. Repeat steps 5 through 9 for each of the VersaTaper Steps to be programmed.
11. After all Steps are programmed, press PAUSE/STOP once:
 - All STEP parameters will be confirmed.
 - Step 01 rate and VTBI values will display.
 - VersaTaper summary message will scroll "STEPS:xx, TOTAL VOL:xxxx, DURATION:hh:mm."
12. Press START control to sequence through the programmed steps to view and/or change any step parameters. To change a parameter use steps 5 through 8, as appropriate.

NOTE

To clear the current and all subsequent steps press the RATE control followed by CLEAR/SILENCE to clear rate(s). Press the VTBI control followed by CLEAR/SILENCE to clear VTBI(s).

13. Press PAUSE/STOP twice to power down the instrument.
 - The VersaTaper infusion is stored and ready to operate when the PC-1 pump/controller is powered up.
 - If the instrument is powered down with all the VersaTaper steps set to Rate = 0 and VTBI = 0, the instrument will initialize in a non-VersaTaper mode when powered up.

VersaTaper Operation

1. Prepare the Primary Infusion as described in Section 3.3.1.1.
2. Press the POWER ON control and check:
 - Normal initialization cycle is completed.
 - "VERSATAPER" message scrolls.
 - Step 01 rate and VTBI appear in the respective displays.
 - VersaTaper report message will scroll "STEP:01" and "TIME LEFT:hh:mm".
 - "PRESS START" message will scroll and audio prompt will sound.
3. If desired, press VOLUME INFUSED and CLEAR/SILENCE controls to reset Total Volume Infused to "0".
4. Press and hold the P/C MODE control for at least one second, then release and press the

START control:

- VersaTaper infusion will begin.
- Rate for current step will display.
- VTBI for current step will decrement.
- "STEP:xx", "TIME LEFT:hh:mm" will scroll continuously throughout the VersaTaper infusion.
- Total Volume Infused will increment (press VOLUME INFUSED to view).

Software Release V6.xx and Subsequent

The STEP 01 Rate and VTBI will display "0"s until the P/C MODE control is pressed and held for the required one second.

During VersaTaper Infusion

Press RATE control to view each of the remaining VersaTaper steps in sequence (no changes can be entered). The display will revert to the current step ≈6 seconds after last press of RATE control. VTBI control can be pressed to cancel step viewing.

Upon Completion of VersaTaper Infusion

- Audio prompt sounds.
- "INFUSION COMPLETE - KVO" or "EMPTY CONTAINER - KVO" advisory scrolls.
- A KVO infusion is initiated.

To Exit VersaTaper Mode

1. Press the PAUSE/STOP control twice to power down the instrument.
2. Press and hold the CLEAR/SILENCE control while actuating the POWER ON control.
3. The PC-1 pump/controller will initialize in the normal infusion mode.

Titration Keypad/Series v7.xx & Sub. Software

To Enter the VersaTaper or AutoTaper Mode

1. Confirm that the PC-1 is powered off.
2. Press the POWER ON control while simultaneously pressing and holding the VTBI control.
 - "888.8" will show in both displays.
 - "PC-1 Vx.xx" scrolls once across the operator information display.
3. Release the VTBI control when the audio tone has sounded and "888.8" no longer shows in both displays.
 - "VersaTaper: Setup" will scroll.

NOTE

If "VersaTaper: Setup" does not scroll; repeat steps 1-3.

- To activate VersaTaper Setup - press START.

Press VTBI to select "AutoTaper: Ramp Time"

- "AutoTaper: Ramp Time" scrolls on the operator information display.
- To activate "AutoTaper: Ramp Time" - press START.

Press VTBI again to select "AutoTaper: Setup"

- "AutoTaper: Setup" scrolls on the operator information display.
- To activate "Auto Taper: Setup" - press START.

Press VTBI again to select "AutoTaper: Patient"

- "AutoTaper: Patient" scrolls on the operator information display.
- To activate "AutoTaper: Patient" - press START.

Press VTBI once again to select Powerdown

- "Powerdown" scrolls on the operator information display.
- Press START to power down.

NOTE

VTBI control may be pressed again to return to VersaTaper: Setup.

NOTE

Controller delivery mode and empty container detector operation are not available for use in VersaTaper, AutoTaper and AutoTaper Patient modes.

VERSATAPER MODE

To Set Up a VersaTaper Infusion

1. Follow instructions listed above under **To Enter VersaTaper or AutoTaper Mode** and press START to enter VersaTaper: Setup
 - The Pump delivery mode indicator illuminates.
 - Previously entered parameters for STEP 01 will display.
 - "VERSATAPER: SETUP" will scroll.

- "MACRO" or "MICRO" will scroll if STEP 01 parameters were entered in a previous program.
 - "10 PSI" or "517 mmHg" will scroll if locked in.
2. Press the RATE control and set the desired rate for VersaTaper STEP 01.
 - The "STEP: 01" advisory will display.
 3. Press the VTBI control and set the desired VTBI for VersaTaper STEP 01.
 4. Press the START control.
 - The "STEP: 01" advisory will be replaced by "STEP: 02" and previously programmed parameters for STEP 02 will display. (If STEP 02 was not previously programmed, zeros will display.)
 5. Repeat instructions 2, 3, and 4 to program VersaTaper STEP 02. At the end of instruction 4, the "STEP: 02" advisory will be replaced by "STEP: 03".
 6. Repeat this cycle to program VersaTaper STEPS 03 through 20, as required.
 7. Press PAUSE/STOP once to enter all programmed VersaTaper parameters.
 - STEP 01 rate and VTBI parameters will display.
 - The following advisories will scroll:
 - a. "STEPS: (number of STEPS programmed)".
 - b. "TOTAL VOL: (total VTBI for all STEPS programmed)".
 - c. "DURATION: (total time in hours and minutes to complete all STEPS programmed)".
 if desired, press START to view each of the programmed VersaTaper STEP parameters in sequence. VersaTaper STEP parameters can also be changed, if required, following instructions 2, 3, and 4.

NOTE

To clear all parameters of the viewed STEP and all subsequent STEPS to "0", press RATE, CLEAR/SILENCE, VTBI, CLEAR/SILENCE, and START.

8. Press PAUSE/STOP a second time to power off the instrument. The VersaTaper infusion is programmed and ready for operation when the instrument comes up in VersaTaper Mode at next power on. If the instrument is powered off after clearing all STEP parameters to zero, then the instrument will initialize in the normal infusion mode at next power on.

PC-1

To Operate a VersaTaper Infusion

1. Prepare the Primary infusion as described in the non-VersaTaper Mode setup section.
2. Press the POWER ON control.
 - "888.8" will show in both displays and "PC-1 Vx.xx" scrolls once.
 - Audio tone sounds once.
 - " - - -" appears in the rate and VTBI displays.
 - The "VERSATAPER" advisory will scroll.
3. If desired, press VOLUME INFUSED and CLEAR/SILENCE to clear the Total Volume infused to "0" before beginning the VersaTaper infusion.
4. Press and hold the P/C MODE control for at least one second.
 - STEP 01 rate and VTBI parameters will display.
 - "STEP: 01" and "TIME LEFT: xx:xx" will scroll.
 - The "PRESS START" prompt will scroll and an audio tone will begin to sound.
5. Press the START control.
 - The instrument will begin the VersaTaper infusion with STEP 01, and will continue through the STEPS of the program until the last STEP is completed.
 - The rate of the active STEP will display.
 - The VTBI of the active STEP will decrement.
 - "STEP: xx TIME LEFT: xx:xx VERSATAPER" will scroll continuously throughout the VersaTaper infusion.
 - The total volume infused increments as the programmed VersaTaper STEPS infuse in sequence. (Press VOLUME INFUSED to view.)

NOTE

During the VersaTaper infusion, press RATE to view each of the programmed STEP parameters in sequence. (No changes can be made.) The display will automatically revert to the current STEP number and will display STEP parameters after approximately 6 seconds, or press VTBI to cancel the viewing.

Upon completion of the infusion:

- An audio prompt sounds.
- An "INFUSION COMPLETE - KVO" or "EMPTY CONTAINER - KVO" advisory scrolls.
- A KVO infusion is initiated and shown in the RATE display.
- A VersaTaper infusion may not be restarted from the KVO state.

To Stop a VersaTaper Infusion

1. Press PAUSE/STOP control twice:
 - "OFF 3" displays; "3" decrements to "1" and then the instrument powers down.



To Resume a VersaTaper Infusion

1. Press POWER ON control to power on the instrument:
 - Following initialization "VERSATAPER" will scroll.
 - The RATE and VTBI displays will show " - - -".
 - The operating indicator for the last selected delivery mode will illuminate.
2. Press P/C MODE control for 1 second:
 - The rate and VTBI for the last active Step will appear in the RATE and VTBI displays.
 - "CONTINUE PREVIOUS INFUSION? ↑ = YES ↓ = NO STEP xx TIME LEFT xx:xx VERSATAPER" will scroll.
 - After 30 seconds, Audio prompt will sound.
 - a. Press to continue the previous infusion:
 - "YES" will appear in the VTBI display.
 - "PRESS START" will scroll.
 - After 30 seconds, audio prompt will sound.
 - b. Press START control twice:
 - Previous infusion will resume from the point it was stopped.
 - "STEP: xx TIME LEFT: xx:xx VERSATAPER" will scroll.
 - Pump mode operating indicator will flash or
 - c. Press to reset the instrument to the beginning of the programmed VersaTaper infusion:
 - "NO" will appear in the VTBI display.
 - "PRESS START" will scroll.
 - d. Press START control twice to begin a new VersaTaper infusion:
 - "STEP: xx TIME LEFT: xx:xx VERSATAPER" will scroll.
 - RATE and VTBI displays will show the rate and VTBI for Step 01.
 - The pump mode operating indicator will flash.

AUTOTAPER MODE (must be entered from VersaTaper: Setup using VTBI key)

To Select AutoTaper Ramp Time

1. Press START:
 - "ramp xx%" displays statically (xx = either the last selected ramp % or the default value of 8%).

- Use the  or  to increment or decrement ramp (%) between 6% minimum and 12% maximum.

To Setup an AutoTaper Infusion

1. Press VTBI control once:
 - "AutoTaper: Setup" scrolls.
2. Press START:
 - "SET VTBI" and "AUTOTAPER: SETUP" scroll.
 - "----" appears in the VTBI display.
 - The PUMP delivery mode indicator illuminates.
3. Press the VTBI control:
 - Last selected VTBI or "0" flashes in the VTBI display.
 - Use the data entry controls to set the VTBI (between 200 mL minimum and 7896 mL maximum).
4. Press START:
 - Entered VTBI value displays steadily.
 - "SET DURATION" scrolls.
 - Last selected time factor "xxxx" displays statically alternating with the scrolled message.
 - Use the "1", "10" and CLEAR/SILENCE controls to set delivery time (between 1 and 24 hours).
5. Press START:
 - AutoTaper summary message scrolls
"DURATION: xx:xx MAX RATE: xxx RAMP %: xx".

NOTE

Entry of a volume/time parameter that results in a maximum rate >350 mL/hr will cause the "VOLUME/TIME ERROR: SET VTBI" message to scroll

6. Press PAUSE/STOP control once to power down:
 - "OFF 3" displays; "3" decrements to "1" and then the instrument powers down.

To Operate an AutoTaper infusion

1. Prepare the infusion as described in the Primary infusion setup section.
2. Press POWER ON to initialize the instrument:
 - "888.8" will display in both displays and "PC-1 v7.xx or subsequent" scrolls once.
 - Audio tone sounds once.
 - PUMP delivery mode indicator illuminates.
 - "----" appears in both the RATE and VTBI displays.
 - "AUTOTAPER" scrolls.

3. Press the P/C mode control to enable the START control for the AutoTaper infusion.
4. Press the START control:
 - RATE display dynamically shows the rate value for that increment of the ramp currently being evoked.
 - VTBI display shows the total volume to be infused.
 - "TIME LEFT: xx:xx AUTOTAPER" scroll continuously (the time display is dynamic and displays the actual time remaining).
 - The delivery mode operating indicator flashes to confirm the infusion is in progress.

To Stop an AutoTaper Infusion

1. Press PAUSE/STOP control twice:
 - "OFF 3" displays; "3" decrements to "1" and then the instrument powers down.

To Resume an AutoTaper Infusion



1. Press POWER ON control to power on the instrument:
 - Following initialization, "AUTOTAPER" scrolls.
 - RATE and VTBI displays show "----".
 - Delivery mode operating indicator for the previously selected delivery mode illuminates.
2. Press and hold P/C MODE control for 1 second:
 - The rate and the volume remaining to be infused when the infusion was stopped will appear in the RATE and VTBI displays.
 - "CONTINUE LAST xxx:xx OF PREVIOUS INFUSION? ↑ = YES ↓ = NO AUTOTAPER" will scroll.
 - After 30 seconds, audio prompt will begin.
- a. Press  to continue the previous infusion:
 - "YES" will appear in the VTBI display.
 - "PRESS START" will scroll.
 - "CONTINUE LAST xxx:xx OF PREVIOUS INFUSION? ↑ = YES ↓ = NO" will scroll.
 - After 30 seconds, audio prompt will begin.
- b. Press START control twice:
 - Previous infusion will resume from the point it was stopped.
 - "TIME LEFT: xx:xx AUTOTAPER" will scroll.
 - Delivery mode operating indicator will flash

or
- c. Press  to reset the instrument to the beginning of the infusion:
 - "NO" will appear in the VTBI display.
 - "PRESS START" will scroll.
 - "CONTINUE LAST xx:xx OF PREVIOUS INFUSION? ↑ = YES ↓ = NO" will scroll.

PC-1

- d. Press START control once:
 - "TIME LEFT: xx:xx PRESS START AUTOTAPER" will scroll.
 - VTBI display will show the programmed VTBI.
 - After 30 seconds, audio prompt will sound.
- e. Press START control again to start infusion:
 - "TIME LEFT: xx:xx AUTOTAPER" will scroll.
 - RATE display will show the current operating rate.
 - VTBI display will show the programmed volume to be infused.
 - The pump mode operating indicator will flash.

To Enable an AutoTaper: Patient infusion

1. Following initialization in the VersaTaper and AutoTaper setup mode, press the VTBI control until "AutoTaper: Patient" scrolls on the operator information display.
2. Press START control:
 - "enabled" or "disabled" will appear statically on the operator information display.
 - The delivery mode operating indicator for the last selected delivery mode will illuminate.
3. Use the  or  controls to select "enabled", if necessary.
4. Press VTBI control to select "Powerdown".
5. Press START to power down the instrument.

To Set Up and Operate an AutoTaper Patient Infusion

1. Press POWER ON to power up the instrument (AutoTaper: Patient mode must be enabled):
 - "AUTOTAPER: PATIENT" scrolls.
 - RATE and VTBI displays show " - - - - ".
 - The Pump delivery mode indicator illuminates.
2. Press and hold the P/C MODE control for 1 second:
 - "SET VTBI" scrolls.
 - RATE display is blank.
 - VTBI display shows " - - - - ".
 - After 30 seconds, audio prompt sounds.
3. Press VTBI control:
 - Last selected VTBI or "0" flash in the VTBI display.
 - After 30 seconds, audio prompt sounds.
 - Use data entry controls to set VTBI.
4. Press START control:
 - Selected VTBI value displays steadily.
 - "SET DURATION" scrolls.
 - "xx:xx" displays statically alternating with scrolled message(s).

- Use "10" or "1" data entry controls to set duration.
5. Press START control:
 - "DURATION: xx:xx MAX RATE: xxx RAMP %: XX" and "PRESS START" scroll.
 - After 30 seconds, audio prompt sounds.

NOTE

Entry of a volume/time parameter that results in a maximum rate >350 mL/hr will cause the "VOLUME/TIME ERROR: SET VTBI" message to scroll.

6. Press START control again to start infusion:
 - "TIME LEFT: xxx:xx AUTOTAPER" scrolls.
 - RATE display shows active delivery rate.
 - VTBI display shows volume to be infused.
 - The pump delivery mode indicator flashes.

To Stop an AutoTaper Patient Infusion

1. Press PAUSE/STOP twice:
 - "OFF 3" displays; "3" decrements to "1" and then the instrument powers down.

To Resume an AutoTaper Patient Infusion

1. Press POWER ON control to power on the instrument:
 - Following initialization, "AUTOTAPER: PATIENT" scrolls.
 - RATE and VTBI displays show " - - - - ".
 - The pump delivery mode indicator illuminates.
2. Press and hold P/C MODE control for 1 second:
 - The active rate and the volume remaining to be infused when the infusion was stopped will appear in the RATE and VTBI displays.
 - "CONTINUE LAST xxx:xx OF PREVIOUS INFUSION? ↑ = YES ↓ = NO AUTOTAPER" will scroll.
 - After 30 seconds, audio prompt will begin.
- a. Press  to continue the previous infusion:
 - "YES" will appear in the VTBI display.
 - "PRESS START" will scroll.
 - "CONTINUE LAST xx:xx OF PREVIOUS INFUSION? ↑ = YES ↓ = NO" will scroll.
 - After 30 seconds, audio prompt will begin.
- b. Press START control:
 - RATE and VTBI displays will show parameters active when infusion was stopped.
 - "TIME LEFT: xx:xx PRESS START AUTOTAPER" will scroll.
 - After 30 seconds, audio prompt will sound.

- c. Press START to resume previous autotaper infusion:
 - The pump delivery mode operating indicator will flash.
 - "TIME LEFT xx:xx AUTOTAPER" will scroll
- or
- d. Press (5) to reset the instrument to the beginning of the infusion.
 - "NO" will appear in the VTBI display.
 - "PRESS START" will scroll.
 - "CONTINUE LAST xx:xx OF PREVIOUS INFUSION? ↑ = YES ↓ = NO" will scroll.
 - After 30 seconds, audio prompt will sound.
- e. Press START control once:
 - "SET VTBI" will scroll.
 - RATE display will be blank.
 - VTBI display will show " - - - - ".
 - After 30 seconds, audio prompt will sound.
3. Follow steps 3-6 in Section: **To setup and operate an AutoTaper Patient infusion.**

To Exit the VersaTaper/AutoTaper Mode

1. Press the PAUSE/STOP control twice, which will power off the instrument.
2. Press the POWER ON control while simultaneously pressing and holding the CLEAR/SILENCE control until an audio tone has sounded.
3. The PC-1 may now be operated as described in the normal infusion mode sections of this manual.

3.3.1.3 Battery Powered Operation

The PC-1 pump/controller will provide normal operation under battery power for a limited period of time for ambulatory use or as a backup to primary power in the event of a power interruption. Battery operating life can be extended by utilizing delivery rates with low motor current draw. The following procedures are recommended for battery powered operation:

1. A new fully-charged battery will provide 5 hours of instrument operation (delivery rate of 125 mL/hr).

NOTE

From a HELP BATTERY condition, recharging requires 4 hours with the instrument off, or 18 hours with the instrument operating at 125 mL/hr.

Any time a LOW BATTERY advisory is displayed, the battery should be fully recharged prior to subsequent battery powered instrument operation.

2. Configure the pump for operation in the same manner as for normal operation (see paragraph 3.3.1.1).
3. Actuate the POWER ON Control. All indicators and displays will react as in normal operation (see paragraph 3.3.1.1 e), except the Battery Operation Indicator will remain on.
4. Install administration set in the pump.
5. Set Delivery Mode, Rate and VTBI in the same manner as for normal operation.
6. Press START Control. Battery operation indicator will flash.

CAUTION

Instruments that have not been operated for a period of 30 days must be plugged in and charged for 24 hours prior to use.

Software Release V6.xx and Subsequent

- When AC power is removed, instrument will not sound changeover audio
- Battery Operation indicator will flash during battery operation
- "ON BATT" will scroll twice every 30 seconds during battery operation [v6.45 ONLY]
- During battery operation, Operator Information Display will be dimmed; at Low Battery, display brightness will be further dimmed.
- At Low Battery, Rate and VTBI displays will flash.

Software Release V6.3x and Subsequent

When the instrument is disconnected from AC power while operating or powered up on battery, an elapsed time counter will initiate and after 5 hours will signal a Timed Low Battery condition:

- "LOW BATTERY..." will scroll.
- Audio prompt will sound.
- Reconnecting AC power will cause time counter to decrement at the same rate.
- Voltage threshold Low Battery will override Timed Low Battery.

PC-1

3.3.2 Maintenance/Diagnostic Mode

The Maintenance/Diagnostic Mode is incorporated into the PC-1 pump/controller to provide biomedical personnel access to the diagnostic test routines. Entry into the Maintenance Mode is accomplished by performing the following procedure:

1. Press and hold the COMPUTER CONTROL/MONITOR switch while actuating the POWER ON control to initialize the instrument.
 - Assure all indicators illuminate, all segments of the RATE and VTBI displays illuminate ("888.8"); the operator information display remains blank.
 - "PC-1 Vx.xx" scrolls once across the operator information display (x.xx represents the installed software version).

Software Release v2.xx through v6.xx

- "maintenance Vx.xx To Exit Press STOP" message scrolls continuously.

Software Release v7.xx and Subsequent

- "Diagnostics V7.xx To Exit Press <stop>" message scrolls continuously
- Keyclick audio sounds once.

2. Each actuation of the COMPUTER CONTROL/MONITOR switch will sequentially step control from one test to the next in the following sequence:

Software Release V2.xx and V5.xx

Lamp Test with Audio
Keypad Test
Error Log Display
Motor Homing Test
Pump Test
Serial Port Tests
A/D Voltage Display
Input Port Display
Communications Setup
Language
Powerdown Test

Software Release V5.59 & V6.xx

Error Log Display
Pump Test
A/D Voltage Test
Input Port Display
Communications Setup
Serial Port Test
Language Selection

Software Release v7.xx and Subsequent

Error Log Display
Pump Test
Motor Homing Test
A/D Voltage Test
Input Port Display
Lamp Test
Keypad Test
Communications Setup
Serial Port Test
ROM CRC Display
ROM Checksum Display (V7.xx only)
Battery Data Display
Audio Test
Powerdown Test

Each of these tests, when selected, is accompanied by a scrolled confirmation message on the Operator Information Display.

3. Each test is initiated by actuating the START control. The scrolled test identifier is replaced with a statically displayed test phase identifier. The PAUSE/STOP control is used to change test phases within a test routine. Exiting from a subroutine loop is accomplished by actuating the COMPUTER CONTROL/MONITOR switch which selects the next test in the above listed test sequence. Detailed test procedures are found in Section 5 of this manual.
4. Software Releases v2.xx through v5.xx
Actuation of the PAUSE/STOP control while a test identifier is scrolling will interrupt the test sequence, skip the remaining tests and go to the powerdown test.

Software Release v6.xx ONLY

The Maintenance Mode can only be exited when the "Maintenance V6.xx To exit press <stop>" message is scrolling by pressing the PAUSE/STOP control.

Software Release v7.xx and Subsequent

The Powerdown Test must be selected and START control pressed to exit the Diagnostic mode.

3.4 OPERATOR INFORMATION DISPLAY AND ALARM RESPONSE PROCEDURES

In the normal operating mode, four types of visual displays are presented to the operator: prompts, advisories, alarms and malfunctions. Under certain conditions, it is possible for one or more types of messages to be active at the same time. Should this situation occur, the messages will be sequenced such that each message will display once before any message is repeated. The display of "Volume Infused" will take precedence over prompts and advisories, but not over alarm or malfunction messages.

Table 3-2 lists the Status/Alarm Displays presented by the PC-1 pump/controller, identifies the probable cause and defines the recommended operator response.

The PC-1 Visual Indicator Displays are characterized as follows:

RATE and VTBI Displays

Type Presentation

- 1 0.5 sec flash
- 2 Steady

STATUS/ALARM Display

- 3 Scroll
- 4 Interrupted Scroll (Sensor initiated message takes precedence over Prompt)
- 5 Static (Applicable ONLY in the maintenance and VersaTaper modes)

3.5 AUDIO ALERT SYSTEM

The PC-1 pump/controller is programmed to produce six distinct audio alerts. The attributes of each are described in Figure 1-2.

PC-1

Table 3-2. PC-1 pump/controller Status/Alarm Displays

Condition/Display	Cause	Response
PROMPTS		
A Prompt is a visual alert requesting the instrument operator to take a specific action.		
PRESS START Audio - Prompt Visual - continuous scroll	Initiates following actuation of the latter of RATE and VTBI in conjunction with programming an infusion, or 12 seconds after an alarm is cleared, or 2 minutes after PAUSE is selected.	Press START Control.
SET RATE Audio - Prompt Visual - continuous scroll	Follows actuation of RATE control, or if START is pressed with rate set to "0".	Press RATE and set rate to a non-zero value.
SELECT P/C MODE Audio - none Visual - scrolls once	Follows initialization sequence during instrument power up, if P/C Mode is not locked out.	Select Pump or Controller Mode.
SET VTBI Audio - Prompt Visual - continuous scroll	Follows actuation of VTBI control, or if START is pressed with VTBI set to "0".	Press VTBI control and set VTBI to a non-zero value.
ADVISORIES		
An Advisory is a visual and audio alert to the instrument operator that an extraordinary, but non-critical condition exists, and operator action should be taken as soon as possible.		
SECONDARY Audio - (6 beeps when complete, when enabled) Visual - continuous scroll	Secondary infusion in progress.	None.
PRIMARY Audio - none Visual - continuous scroll	SEC/Piggyback control actuated while operating in Secondary and after changeover from secondary to primary infusion.	None.
INFUSION COMPLETE - KVO Audio - Prompt Visual - continuous scroll	Programmed VTBI reaches 0, (All except PC-1 CE - V8.xx 220V) or an ALL infusion complete using ECD.	Press PAUSE/STOP control twice or set up another infusion.
All except PC-1CE - V8.xx 220V EMPTY CONTAINER - KVO Audio - Prompt Visual - continuous scroll	Empty container detected by ECD before programmed VTBI delivered, or when ALL infusion is used.	Press PAUSE/ STOP control twice or set up another infusion.
LOW BATTERY Audio - Prompt Visual - continuous scroll	5.8 ±0.1V threshold detected; ≈0.5 hour battery operating time remaining.	Connect AC power cord to outlet.

Table 3-2. PC-1 Pump/Controller Status/Alarm Displays

Condition/Display	Cause	Response
ADVISORIES (cont)		
PAUSE Audio - Advisory (immediately), Prompt (after 2 minutes) Visual - continuous scroll	PAUSE/STOP Control pressed once.	Press START to resume infusion, or press PAUSE/STOP again to shut down instrument.
MAINTENANCE [v2.xx/5.xx/6.xx] Audio - beeps once Visual - continuous scroll	COMPUTER CONTROL/MONITOR switch pressed and held during Power On sequence.	DO NOT USE ON PATIENT. For use by biomedical technician only.
DIAGNOSTIC [v7.xx and subsequent] Audio - beeps once Visual - continuous scroll	COMPUTER CONTROL/MONITOR switch pressed and held during Power On sequence.	DO NOT USE ON PATIENT. For use by biomedical technician only.
LOW FLOW Audio - Advisory Visual - continuous scroll	In Controller mode, distal tubing in-line pressure equals bottle height resulting in no flow.	Remedy cause of Low Flow condition or raise IV bottle.
TOTAL VOL INFUSED Audio - none Visual - single scroll	VOLUME INFUSED control actuated once.	None (Numeric value in VTBI display is cumulative Primary plus Secondary).
SEC VOL INFUSED Audio - none Visual - single scroll	VOLUME INFUSED control actuated twice while in Secondary state.	None (Numeric value in VTBI display is Secondary solution volume ONLY).
<u>Fractional Keypad/Series V5.xx and Subsequent Software</u>		
MICRO Audio - none Visual - scroll	Instrument has been initialized in the MICRO delivery mode.	Fractional rate and VTBI parameters are accepted by the instrument.
MACRO Audio - none Visual - scroll	Instrument has been initialized in the MACRO delivery mode.	Integer rate and VTBI parameters are accepted by the instrument.
VERSATAPER Audio - none Visual - scroll	Instrument is operating in the VersaTaper delivery mode.	None.
VERSATAPER: SETUP Audio - none Visual - scroll	Instrument has been initialized in the VersaTaper Setup mode.	VersaTaper steps 1-20 can be sequentially programmed for rate and VTBI.
STEP:xx Audio - none Visual - static	Identifies the VersaTaper step to be programmed.	Enter rate and VTBI values for the step identified.

PC-1

Table 3-2. PC-1 Pump/Controller Status/Alarm Displays



Condition/Display	Cause	Response
(VersaTaper Summary) - STEPS:xx, TOTAL VOL:xxxx, DURATION:hh:mm Audio - none Visual - continuous scroll	After programming the desired VersaTaper Steps, the PAUSE/ STOP control was actuated to enter and summarize VersaTaper program.	View and edit VersaTaper program as required.
(VersaTaper Report) - STEP:xx, TIME LEFT:hh:mm Audio - none Visual - continuous scroll	Instrument has been powered up in the VersaTaper operate mode.	None - awaiting start of the VersaTaper infusion.
Software Release V6.xx and Subsequent		
10 psi or 517 mmHg (v8.13 only) Audio - none Visual -scrolls until START or COMPUTER CONTROL/MONITOR switch is pressed	Pump mode is locked into 10 ±2 psi occlusion detection.	None - Time to occlusion at low rates will be significantly increased.
Software Release V6.2x through V6.4x		
ON BATT Audio - none Visual - flashes twice every 20 seconds	Instrument is operating on battery power.	Connect AC power cord to a suitable AC power source.
Software Release V6.3x and Subsequent		
LOW BATTERY... Audio - Prompt Visual - continuous scroll	Five hours have elapsed since an operating instrument was disconnected from AC power.	Connect the instrument to an AC power source.
Software Release v7.xx and Subsequent		
CONTINUE PREVIOUS INFUSION? ↑=YES ↓=NO STEP: xx TIME LEFT: xx:xx VERSATAPER Audio: none Visual: continuous scroll	VersaTaper infusion has been reentered after an incompleted prior infusion.	Use the  or  controls to continue or discontinue previous infusion.
CONTINUE PREVIOUS INFUSION? ↑=YES ↓=NO Audio: none Visual: continuous scroll	The Yes option to continue the previous infusion has been selected.	None. Pressing  will change the selection from continue to discontinue.
yes Audio: none Visual: static display	The Yes option to continue the previous AutoTaper/VersaTaper infusion has been selected.	Press START to resume previous infusion.
no Audio: none Visual: static display	The No option to discontinue the previous AutoTaper/VersaTaper infusion has been selected.	Press START to begin a new infusion.

Table 3-2. PC-1 Pump/Controller Status/Alarm Displays

Condition/Display	Cause	Response
ADVISORIES (cont)		
AutoTaper: Ramp Time Audio: none Visual: continuous scroll	AutoTaper Ramp Time setup mode has been selected.	Press START to enable ramp time (%) selection.
ramp% xx Audio: none Visual: static display	AutoTaper ramp% selection mode is enabled.	Use or to select ramp % (between 6 and 12%, default setting 8%).
AutoTaper: Setup Audio: none Visual: continuous scroll	AutoTaper setup mode has been selected.	Press START to enable selection of AutoTaper infusion parameters.
AUTOTAPER: SETUP Audio: none Visual: continuous scroll	AutoTaper setup mode has been enabled.	Use infusion parameter entry controls to program AutoTaper infusion.
SET DURATION Audio: none Visual: alternating scroll	AutoTaper setup mode is ready for infusion duration input.	Use "10" and or "1" controls to set duration (between 1 and 24 hours).
DURATION: xx:xx MAX RATE: xxx RAMP %: xx Audio: none Visual: continuous scroll	AutoTaper Setup summary message.	None. Press PAUSE/STOP to exit AutoTaper: Setup.
AUTOTAPER Audio: none Visual: continuous scroll	PC-1 pump/controller is ready or operating in AutoTaper mode.	If in ready condition, press and hold P/C MODE control for 1 second; then press START.
TIME LEFT: xx:xx AUTOTAPER Audio: none Visual: continuous scroll	PC-1 pump/controller is ready or performing an AutoTaper infusion.	None.
CONTINUE LAST xx:xx OF PREVIOUS INFUSION? ↑=YES ↓=NO AUTOTAPER Audio: none Visual: continuous scroll	AutoTaper infusion has been reentered after an incomplete prior infusion.	Use the or controls to continue or discontinue previous infusion.
AutoTaper: Patient Audio: none Visual: continuous scroll	AutoTaper Patient mode enable has been selected.	Use or controls to enable or disable AutoTaper Patient infusion mode.
enabled Audio: none Visual: static display	AutoTaper Patient mode has been enabled.	Press VTBI, then START to exit AutoTaper: Patient setup mode.

PC-1

Table 3-2. PC-1 Pump/Controller Status/Alarm Displays

Condition/Display	Cause	Response
ADVISORIES (cont)		
disabled Audio: none Visual: static display	AutoTaper Patient mode has been disabled.	Press VTBI, then START to exit AutoTaper: Patient setup mode.
VOLUME/TIME ERROR: SET VTBI Audio: none Visual: continuous scroll	Volume and/or time input resulted in a max rate >350 mL/hr.	Press VTBI control to re-enter volume and/or time parameter.
ALARMS		
An Alarm condition is signaled by a combined visual and audio alert to the instrument operator that an abnormal situation exists, pumping stops and operator action is required immediately.		
CHECK IV SET Audio - Alarm Visual - continuous scroll	Administration set missing or not properly installed.	Silence alarm, reinstall disposable, press START control.
CLOSE DOOR Audio - Alarm Visual - continuous scroll	Door open while infusing with Flo-Stop in no flow position.	Close and latch door, press START control.
FLO-STOP OPEN/CLOSE DOOR Audio - Alarm Visual - continuous scroll	Pumping chamber access door open and Flo-Stop is in open free flow position.	Close and latch door or close roller clamp on administration set, then silence alarm.
All except PC-1CE V8.xx 220V. CHECK ECD Audio - Alarm Visual - continuous scroll	START control actuated with VTBI set to ALL and ECD has become disconnected or failed.	Silence alarm, connect/repair ECD, or set VTBI to a parameter (not ALL), press START.
AIR IN LINE Audio - Alarm Visual - continuous scroll	ALL sensor activated during infusion or KVO state.	Silence alarm, remove air from set tubing, press START Control.
OCCLUDED-PATIENT SIDE Audio - Alarm Visual - continuous scroll	Elevated backpressure sensed while infusing in the Pump mode.	Silence alarm, Clear occlusion, press START control.
OCCLUDED-FLUID SIDE Audio - Alarm Visual - continuous scroll	Proximal vacuum sensed while infusing in the Pump mode.	Silence alarm, clear occlusion, press START control.
OCCLUDED Audio - Alarm Visual - continuous scroll	In Controller mode when: LOW FLOW condition exists for >60 seconds, catch up time for volumetric deficiency exceeds 30 minutes, or an abrupt increase in distal side pressure exceeds occlusion threshold.	Silence alarm, clear occlusion, press START control.

Table 3-2. PC-1 Pump/Controller Status/Alarm Displays

Condition/Display	Cause	Response
ALARMS (continued)		
PARTIAL OCCLUSION-FLUID SIDE Audio - Alarm Visual - continuous scroll	Reduced pressure detected in the proximal tubing resulting from partial filling of the pumping chamber while infusing in Pump mode.	Silence alarm, rectify cause of reduced flow, press START.
Software Release V6.xx and Subsequent		
COMM CABLE Audio - alarm Visual - continuous scroll	Communications interface cable is disconnected.	Reconnect communications cable. Press COMPUTER CONTROL/MONITOR switch, PAUSE or START to resume infusion.
COMM TOUT Audio - alarm Visual - continuous scroll	Communications timeout has occurred.	Press COMPUTER CONTROL/MONITOR switch to change instrument to MONITOR.
KVO Audio - alarm Visual - continuous scroll	Communications cable disconnected or timeout has occurred while infusing. Infusion continues at KVO rate.	Correct problem, press START to resume programmed infusion. Press COMPUTER CONTROL/MONITOR to return to host computer control.
MALFUNCTIONS		
A Malfunction condition is signaled by an audio alert; pumping stops and an Error Log message is recorded. Software detected malfunctions are accompanied by a visual "HELP" message. No visual messages accompany hardware detected malfunctions. Instruments experiencing hardware malfunctions must be taken out of service and the malfunctions must be corrected by a qualified biomedical technician prior to returning the instrument to service.		
HELP BATTERY Audio - Malfunction Visual - continuous scroll	5.5 ±0.1V threshold detected; pumping stops.	Press PAUSE/STOP to power down the instrument; if unable press POWER ON to interrupt power. Plug AC power cord into an AC power source, then re-initialize the instrument.
HELP INTERNAL ERROR Audio - Malfunction Visual - continuous scroll	Software detected malfunction - system failure, pumping stops.	Press PAUSE/STOP control to shut off electrical power. Replace instrument.
(SYSTEM FAILURE) Audio - Malfunction Visual - None	Hardware detected malfunction, pumping stops.	Press POWER ON Control to reset electrical power. Replace instrument.

PC-1

THIS PAGE INTENTIONALLY LEFT BLANK

SECTION 4 - PRINCIPLES OF OPERATION

4.1 INTRODUCTION

This section describes the functional operation of the mechanical and electrical/electronic subsystems of the GEMINI PC-1 Volumetric Infusion Pump/ Controller. The material is presented in a manner and format that is complementary to the troubleshooting routines delineated in Section 5 - Maintenance. The technical descriptions are referenced to the electrical schematics, mechanical diagrams and illustrated parts breakdowns presented in sections 4, 5 and 6.

The functional descriptions presented in this section are divided into two subsections. The first addresses the mechanical system operation and the second describes the electrical/electronic control circuits and operational displays. The electrical theory of operation is described in relation to the Functional Block Diagram depicted in figure 4-2, and can be best understood by following the description on the logic diagrams, display board schematic and interconnect diagram.

4.2 MECHANICAL OPERATION

The following material is presented in a manner that assumes the reader has a basic understanding of the information provided in sections 1 through 3 of this manual and in addition has hands-on experience in setting up and operating the PC-1 pump/controller. Direct observation of the mechanical sequence of events that occur during instrument operation is not possible with the pumping mechanism and strain beam installed in the PC-1 pump/controller. However, by reading the following text while referring to the appropriate figures, a thorough understanding of the instrument's mechanical operation can be acquired.

4.2.1 Physical Description

4.2.1.1 Pumping Mechanism

The pumping mechanism assembly consists of three principle subassemblies: the stepper motor, the camshaft/pumping finger housing and the motion sensor (see Figure 4-1). The stepper motor drive shaft is connected to the camshaft by a flexible coupling. The encoder wheel of the motion sensing assembly is connected directly to the top of the camshaft. The camshaft is configured with 12 vertically staged cam lobes. The eccentric axis of each lobe is offset 30° counterclockwise from the lobe directly above. This positioning provides full forward travel for each pumping finger sequentially from top to bottom during each counterclockwise (when viewed from above) revolution of the camshaft. The cam lobes are evenly spaced except numbers 9 and 10 which are separated by 5/8" to accommodate a strain beam type pressure sensor.

4.2.1.2 Strain Beam (Pressure Transducer)

The strain beam assembly consists of the housing assembly, a strain beam and sensing finger (see Figure 4-3). The housing assembly is mounted on the front case assembly behind the urethane pump seal and is positioned between fingers 9 and 10 of the pumping mechanism. Four strain sensitive resistors are deposited on the strain beam, two on the tension section and two on the compression section.

4.2.2 Functional Operation

4.2.2.1 Pumping Mechanism

In the Normal operating mode, the PC-1 pump/controller is initialized when the POWER ON control is actuated. The pumping mechanism begins operating when an administration set is installed, infusion parameters are programmed and the START control is actuated. A stepper motor is directly coupled to a camshaft which actuates the pumping fingers. Stepper motor speed is variable and it is driven at a speed proportional to the rate programmed for the infusion. Volume to be infused

PC-1

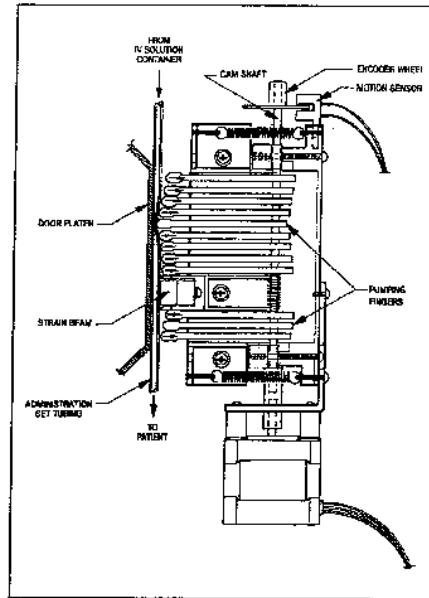

Figure 4-1. PC-1 Pumping Mechanism

(VTBI) is a function of the total number of steps issued to the motor for a programmed infusion rate. An encoder wheel attached to the camshaft and a motion sensor mounted on the pumping mechanism's top plate assembly provides the electronic control system with camshaft's position, direction and speed of rotation. Encoder wheel position data is fed back to the processor through U6 to verify rate accuracy.

When an administration set is installed in the pumping chamber and the access door is closed and latched, the set's Flo-Stop is opened. The pumping segment tubing is compressed between the fully extended pumping finger and the door platen, thus preventing free flow. The pumping mechanism is started following actuation of the START control when performing normal instrument operating procedures. The stepper motor rotates the camshaft at a speed determined by the programmed infusion rate. Each pump cycle consists of 200 motor steps of 1.8° each. Inter-step timing of the motor is varied as necessary to

dampen the inherent non-linearity of peristaltic pumping mechanisms and produce a uniform rate of fluid flow throughout each pumping cycle. The sequential extension and retraction of the pumping fingers from top to bottom results in a downward moving compression zone within the administration set's pumping segment (see Figure 4-1) which creates positive pressure on the outlet side (distal end) of the tubing set. The elastomeric resilience of the pumping segment tubing causes it to return to its cylindrical shape as each of the pumping fingers recede from the extended position. This reshaping creates a vacuum in the proximal tubing and causes fluid from the IV solution container to refill the tubing. This peristaltic-like action results in a constant, controlled flow of IV solution from the container to the patient.

During each pump cycle, between motor steps 62 through 77, the strain beam senses the hydrostatic pressure in the fluid column above the strain beam. In the event there is restricted flow in the tubing between the fluid container and pump and the tubing can not refill completely, the strain beam will sense lower than normal pressure and cause the instrument to enter a LOW FLOW condition when operating in the Controller mode or either a PARTIAL OCCLUSION-FLUID SIDE or OCCLUSION-FLUID SIDE condition when in the Pump mode.

In the Controller mode if the pressure differential between patient and fluid container drops to less than 6 inches (0.22 psi; 1.7 kPa) of water pressure, the pumping mechanism will stop. The micro-processor monitors the duration of a *low flow* condition and then automatically increases the delivery rate, up to a maximum of 10% above the programmed rate. Pumping resumes once the fluid container to patient pressure differential equals or exceeds 12 inches (30.48 cm) [0.43 psi; 3.4 kPa] of water pressure. The increased flow rate allows the instrument to compensate for the period of *low flow* and bring the actual volume infused in line with the programmed infusion parameters. Once the pump has completed this catch-up cycle, the delivery rate reverts to the programmed rate. Should the *low flow* condition persist for more than 1 minute or the calculated time necessary to compensate for the under-infusion condition

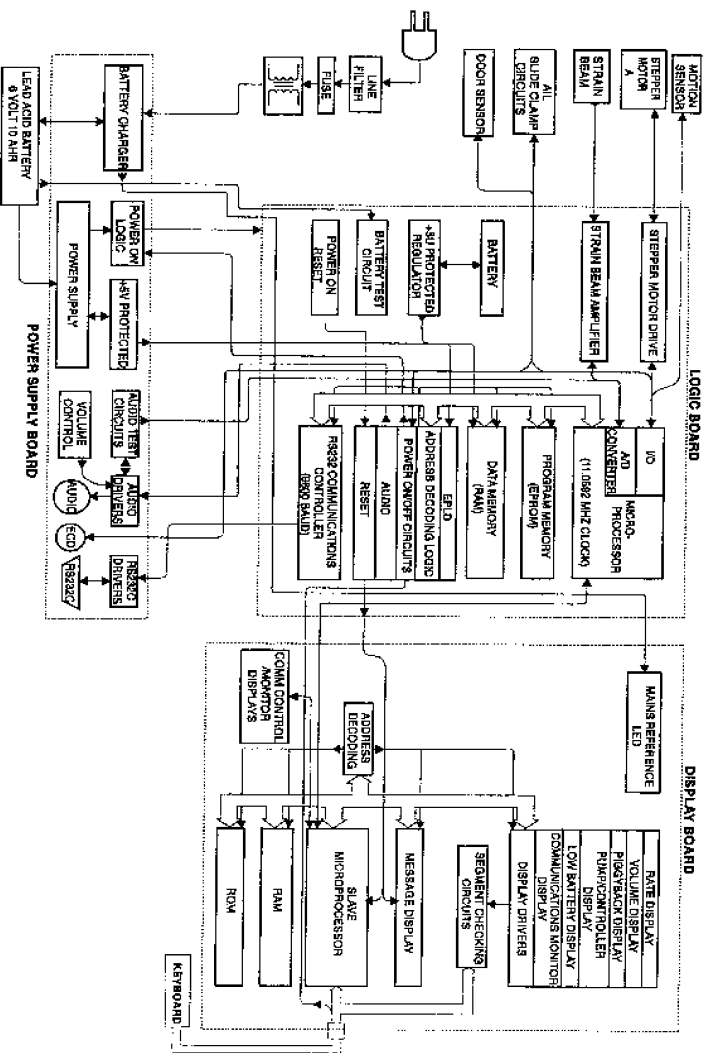

Figure 4-2. Functional Block Diagram [v2.xx/5.xx/6.xx]

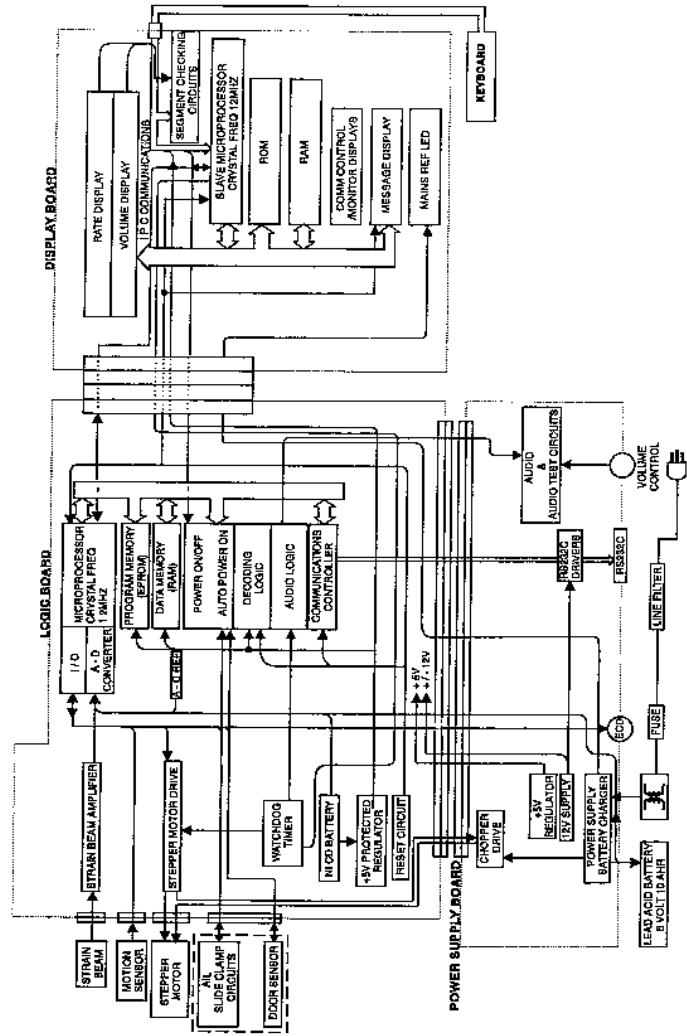

Figure 4-2a. Functional Block Diagram [v7.xx]

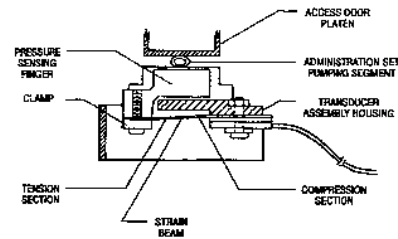

Figure 4-3. Cross Section of Strain Beam Assembly

exceeds 30 minutes, the instrument will enter an Occlusion alarm condition.

During each pump cycle, between motor steps 0 through 20 and 120 through 199, the strain beam measures the pressure in the distal tubing. Any restriction to flow in the distal tubing will cause the pressure to increase and the tubing to expand. The strain beam will sense increasing pressure and when a predetermined threshold is exceeded, the instrument will invoke either an OCCLUSION (Controller mode) or an OCCLUSION-PATIENT SIDE (Pump mode) alarm condition. During any alarm condition, the pumping mechanism stops and appropriate audio and visual alerts are issued. (Between motor steps 21-62 and 77-119 pumping finger positioning precludes the strain beam from reading distal or proximal pressure).

4.2.2.2 Strain Beam (Pressure Transducer)

When the pumping segment of a primed administration set is installed in the PC-1 pumping chamber and the access door is closed, the strain beam will sense the pressure in the tubing. Actual pressure values are a function of pumping finger position within a pump cycle and the hydrostatic pressure in the tubing at the time of measurement. Typically strain beam voltage would be in the range of 1 to 3 volts if the strain beam was looking at the patient-side tubing. During pump operation, a positive pressure increase in the fluid column above or below the pump will cause the tubing to expand and result in deflection of the strain beam. This positive deflection will result in an increase in the potential measured across the strain beam's resistor bridge. A decrease in pressure within the tubing set's fluid column will result in contraction of

the tubing diameter with a resultant negative deflection of the strain beam and reduction in the potential measured across the bridge circuit.

4.3 ELECTRICAL/ELECTRONIC OPERATION

An understanding of the electrical/electronic theory of operation can be acquired by reading the ensuing subsystem descriptions while following the functional schematic for the respective subsystem.

4.3.1 Functional Description

Integer/Fractional Keypad Instruments

The PC-1's electrical/electronic subsystem is operated and controlled by a logic subsystem employing an Intel 8097BH 16 bit microcontroller with an integral A/D converter. The logic subsystem includes a programmed memory containing the instrument's operating code; a non-volatile memory for retention of programmed infusion parameters, error log storage and general system use; a logic decoder to define memory space, implement ready logic, decode sensor strobes and controls audio. The interaction of the logic subsystem components and instrument hardware is functionally depicted in the Logic Block diagram, Figure 4-2. The electrical interconnection of the instrument's components is shown in Figure 4-4.

The memory accessible by the main processor covers 64K bytes of combined internal RAM and register space which is allocated as follows: 256 bytes to internal microprocessor RAM, 3840 bytes to mapped I/O, 4096 bytes to external RAM (Variable, Stack and NVRAM memory) and 56K bytes to external ROM (Program and Data Memory). Figure 4-23 shows the Microprocessor system interconnection.

A 11.0592 MHz crystal external to the microcontroller provides the master clock signal. The microprocessor timing waveforms are shown in Figure 4-5.

Titration Keypad Instruments

The PC-1's electrical/electronic subsystem is operated and controlled by a logic subsystem employing an Intel 80C196KB 16 bit microcontroller with an integral A/D converter. The logic subsystem includes a programmed memory containing

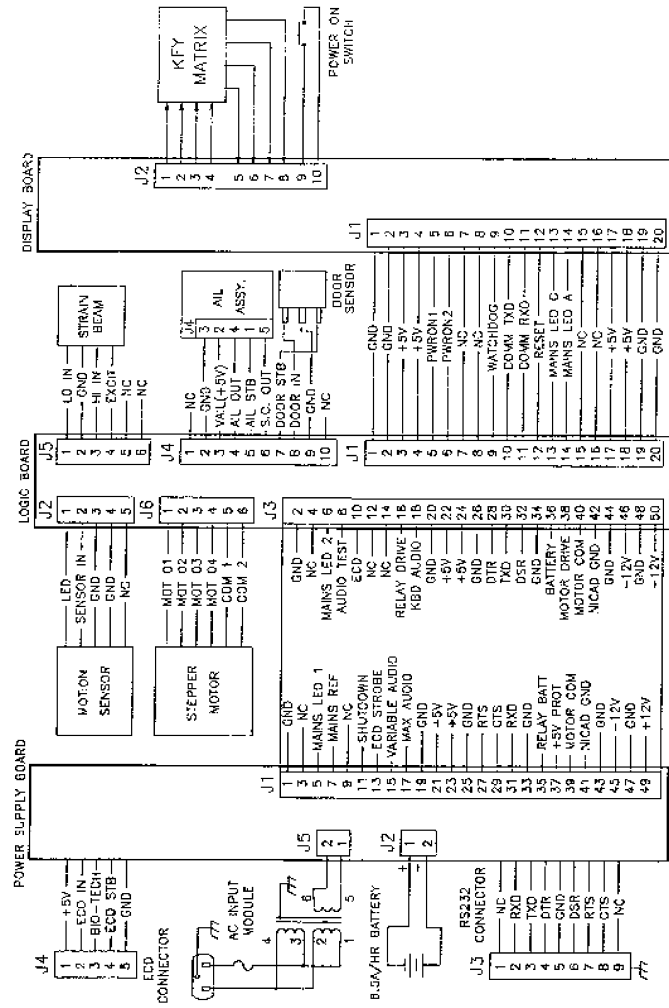

Figure 4-4. PC-1 Pump/Controller Interconnect Diagram

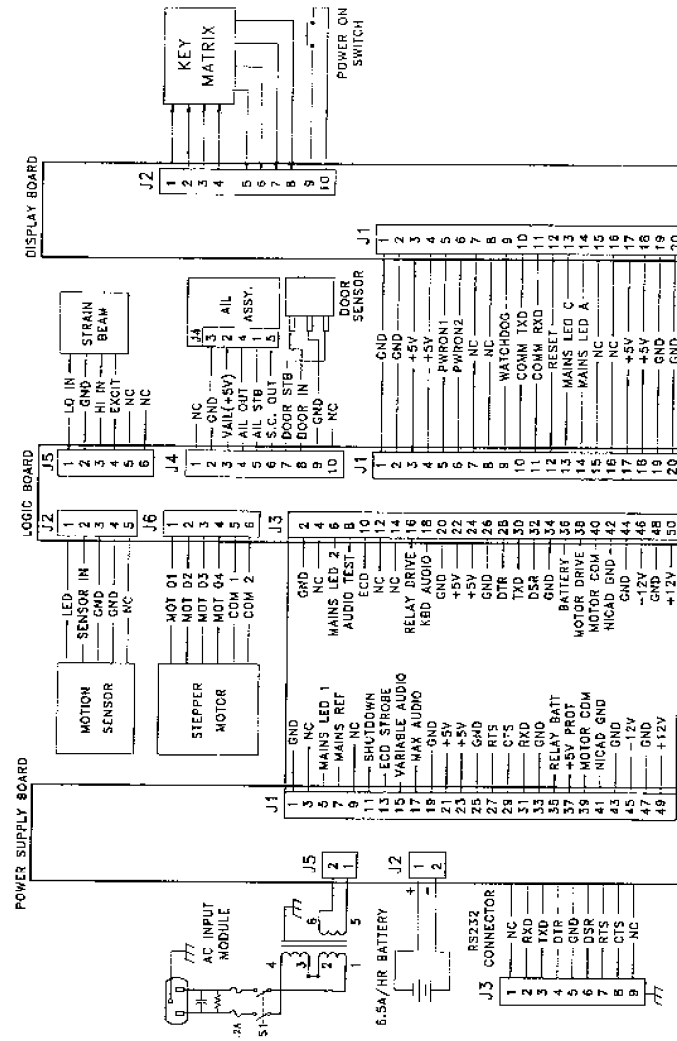

Figure 4-4a. PC-1 Pump/Controller (220V) Interconnect Diagram

PC-1

THIS PAGE INTENTIONALLY LEFT BLANK

PC-1

4.3.2.1 Power On/Power Off Subsystem

The Power On subsystem is incorporated into the Logic and Power Supply Boards and includes an interface through the Display Board to the Keypad. The Power On functional schematic is shown in Figure 4-6, 4-24 or 4-24a. When the POWER ON switch is actuated, +5V_{PROT} is applied via connector J1,6 through a filter to pin #32 [v2.xx/v5.xx/v6.xx] or pin 30 [v7.xx/v8.xx] on the EPLD. Within the EPLD, the PWRON signal is gated with 3 system inhibit signals. If satisfied, the EPLD outputs a relay drive signal that turns on Q10 on the Power Supply Board which closes relay K1 and applies power to the instrument. Approximately 500 ms later, the time constant circuit (CR3, C19 & R20) disables the gate within the EPLD which in turn disables the POWER ON switch. **(For the Titration Keypad Instruments, R9 and C10 are connected to U1-12, 13 to create a delay at U1-11 which disables the gate within the EPLD which in turn disables the POWER ON switch).**

4.3.2.2 Auto Power On Subsystem

The Auto Power On subsystem is comprised of components located on the logic and power supply boards plus the door and slide clamp sensors (see Figure 4-6, 4-24 or 4-24a). When the instrument is in the power off state, the EPLD logic continuously strobes the door sensor. If open, a door open signal is sent to the EPLD which turns on Q2[v2.xx/v5.xx/v6.xx] or Q14[v7.xx/v8.xx] and powers the slide clamp assembly. If the slide clamp detector senses an open Flo-Stop, the EPLD will output a relay driver signal to turn on instrument power and the microprocessor will activate the FLO-STOP OPEN / CLOSE DOOR alarm.

4.3.2.3 5 Volt Protected Subsystem

The 5 volt protected circuit is comprised of components located on the power supply and logic boards (see Figure 4-7). Two +5 volt backup sources are inherent in the system are OR'd together on the logic board and are called +5 volt protected. The source on the Power supply board which is not present on the titration instrument is generated by regulating the main battery voltage,

the second source located on the logic board is generated by a second regulator which regulates the main battery and a backup NiCad battery. The NiCad battery backups the memory, EPLD and audio circuit in event of failure of the primary lead acid battery circuit to ensure valid memory retention and generating an audio signal if the instrument is running at the time of failure. Main battery is monitored by comparator U16 (U9 on titration) and has a low output when battery is ≥ 5.25 volts. When the battery voltage drops below 5.25 volts, the output of the comparator goes high, disabling strobe functions in the EPLD and preventing the ability of the instrument being turned on. Battery voltage is also supplied through diode (CR17) (D12 on titration) to the Voltage Regulator (U19) (Q4 on titration). Voltage regulator output powers RAM (U9) (U2 on titration), the EPLD (U5) and the audio circuit. In addition, regulator output is supplied to the Power On switch, the pass side of the door sensor transistor (Q4) (MOSFET Q12 on titration) and the AIL board power transistor (Q2)(Q13 on titration). The NiCad battery on the logic board provides a battery test signal to the microprocessor's A-D converter. The NiCad battery's charge level is monitored by the 8097 (80C196KB on titration) processor on one of its A-D operations.

4.3.2.3a 5V Power Supply (-7023 Power Supply Board)

The 5V power supply regulates the unswitched battery voltage to 5VDC to provide the +5V protected voltage for RAM backup and system 5V when applied to relay K1. Op amp U6 compares the voltage at U6-3 with the precision 2.5 volt reference at U6-2 established by CR24. When these two voltages are not equal, the output of U6-1 to the gate of FET Q15 is adjusted to equalize the voltages at U6-2,-3. Since the FET output voltage is halved before being applied to U6-3, the FET output will be 5V when U6-2,-3 are equal.

System current is monitored by comparing the voltage drop across R23 with a fixed voltage of 0.1V formed by R21 and R25. If the voltage drop across R23 ever exceeds 0.1V (2 amps) the output of U6-7 goes high forcing U6-3 above 2.5V which turns off FET Q15.

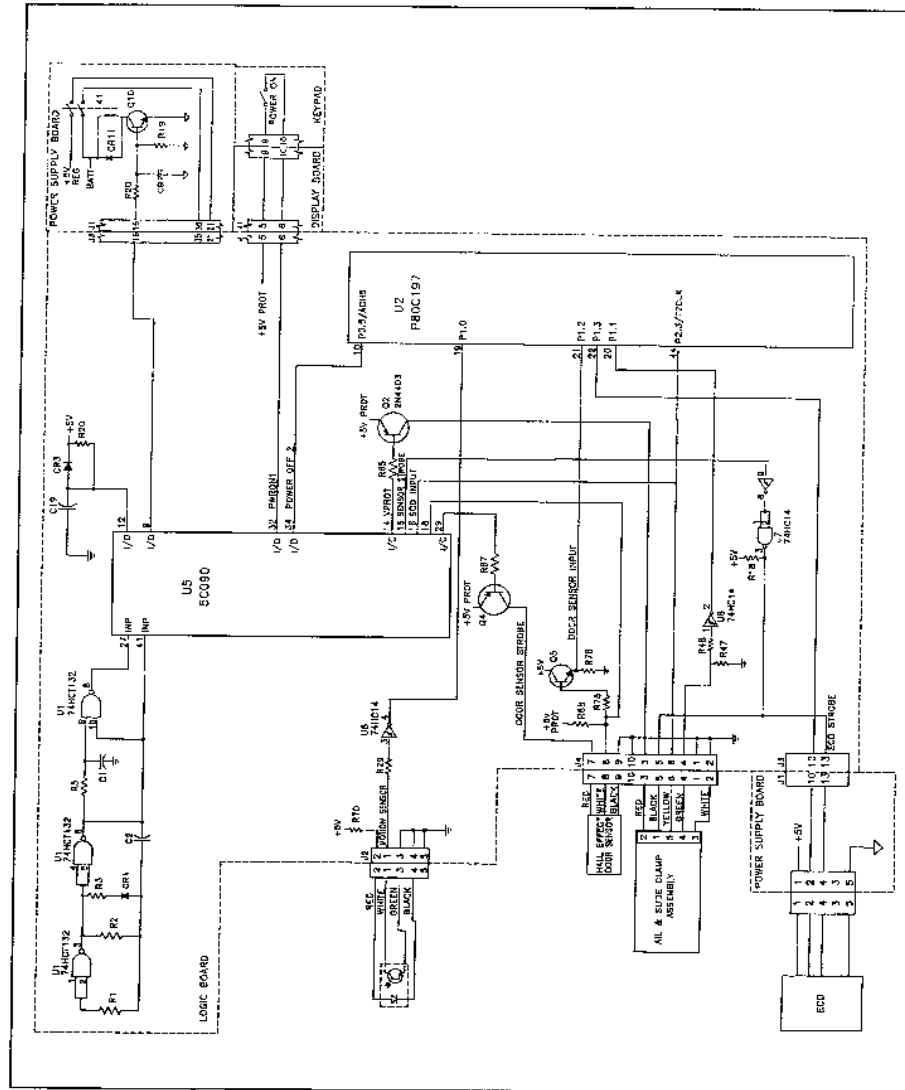

Figure 4-6. Power ON/OFF, Auto Power On and Sensor Signal Functional Schematic [v2.xx/5.xx/6.xx]

PC-1

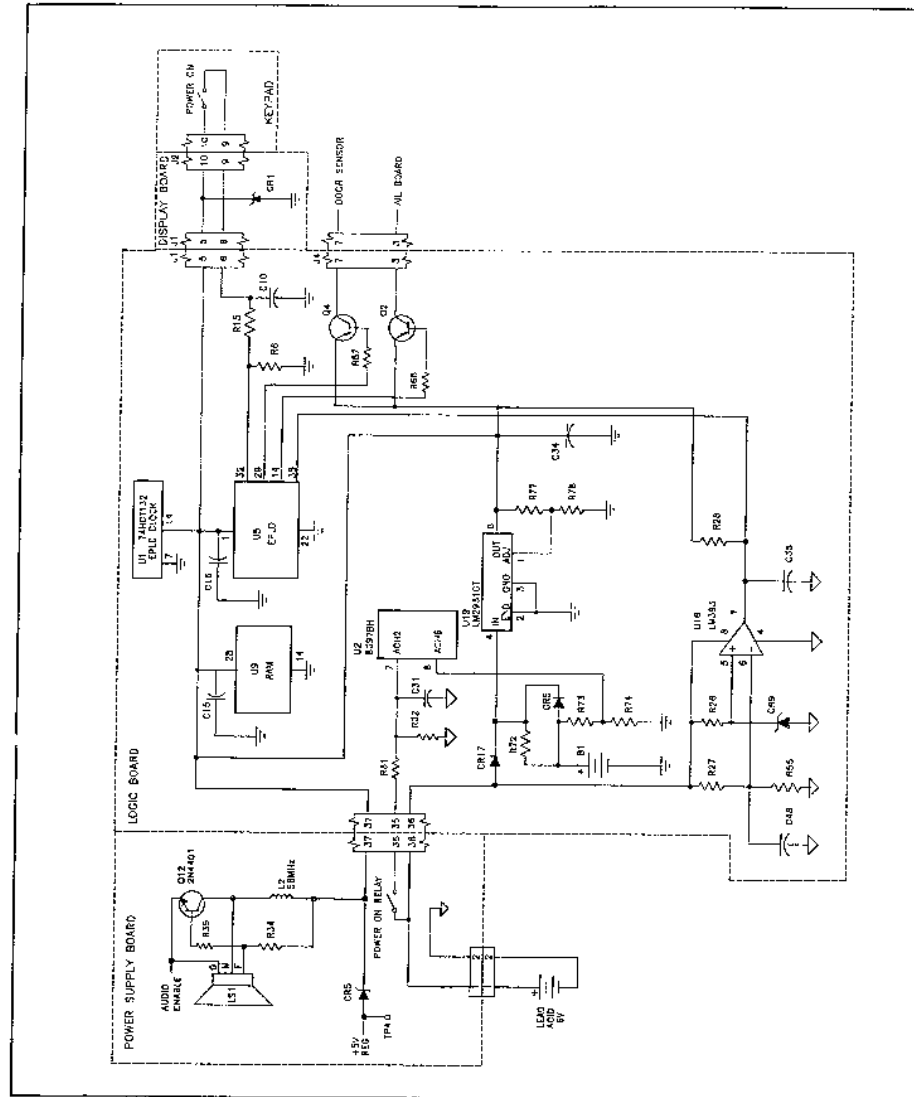

Figure 4-7. 5 Volt Protected Circuit Functional Schematic [v2.xx/5.xx/6.xx]

The 5 V output from FET Q15 is divided down by R27 and R18 and compared by U2-5, and -6 with a 2.5 V reference. If the 5 V output ever exceeds 5.45 V, the output of U2, pin 7 is set low, turning off relay K1 through Q9. Thus, the instrument will either not power-up or will automatically shut down with an audio alarm, if the 5 V power supply is defective.

Titration Keypad Instruments

The 5 volt power supply regulates the battery voltage to 5 volts DC. Op amp U6 compares the voltage at U6-3 with the precision 2.5 volt reference at U6-2 established by CR24. When these two voltages are not equal, the output at U6-1 to the gate of the external p-channel FET is adjusted to equalize the voltages at U4-2,-3. Since the output voltage from the FET is divided by two (via R49 and R50), the resultant output voltage will be 5 VDC when U4-2, -3 are equal. Turning off the 5 volts is accomplished by removing the SW BATT signal which supplies the current to reference CR24. When SW BATT is removed, the 5 volt output regulates at "0" volts, thus shutting down the system.

5 volt system current monitoring is accomplished by comparing the voltage drop across R23 with a fixed 0.1 VDC formed by divider R21, R25. If the voltage across R23 ever exceeds 0.1 Volts (2 amps), the output of U4-7 goes high forcing U4-3 above the 2.5 volt and turns off the external FET.

The 5 volt output is divided down by R18 and R27 and compared by U2-5 and -6 with another 2.5 volt reference (CR25). If the 5 volt output ever exceeds 5.45 VDC, the output of U2-7 is set low turning off FET Q21 via Q9. This has the effect of turning off the SW BATT voltage. The instrument will thus power down (with an audible alarm) if the 5 volt power supply is defective.

4.3.2.4 ±12 Volt DC Power Supply Subsystem

Integer/Fractional Keypad Instruments

The 12 volt power supply circuit resides on the power supply board (see Figure 4-8) and is implemented with a LM3578 switching regulator. Battery is supplied to transformer (T3) at pin #2. Pin #5 of the transformer primary winding is routed to regulator (U5) pin #6 the collector of the internal

pass element. When the transistor is turned on, energy is stored in the primary of T3 until U5 turns off the transistor. The voltage induced in the transformer's secondary is blocked by diodes CR14 and CR15. When the transistor is turned off, the current in the transformer primary is maintained by the collapsing magnetic field inducing current in the transformer secondary which forward biases diodes CR14 and CR15 charging capacitors C13 and C19. The charged capacitors provide +12 and -12 volt outputs. These outputs are monitored by R23 and R29 respectively and are fed back into the chip-resident comparator which adjusts the duty cycle of the transistor to maintain a 24 volt differential across the transformer output terminals.

Titration Keypad Instruments ONLY

4.3.2.4a ±8 Volt DC Power Supply Subsystem

The 8 volt power supply circuit resides on the power supply board (see Figure 4-12b sheet 2) and is implemented with a LM3578 switching regulator. Battery is supplied to transformer (T3) at pin #2. Pin #5 of the transformer primary winding is routed to regulator (U5) pin #6 the collector of the internal pass element. When the transistor is turned on, energy is stored in the primary of T3 until U5 turns off the transistor. The voltage induced in the transformer's secondary is blocked by diodes CR14 and CR15. When the transistor is turned off, the current in the transformer primary is maintained by the collapsing magnetic field inducing current in the transformer secondary which forward biases diodes CR14 and CR15 charging capacitors C13 and C19. The charged capacitors provide +8 and -8 volt outputs. These outputs are monitored by R23 and R29 respectively and are fed back into the chip-resident comparator which adjusts the duty cycle of the transistor to maintain a 24 volt differential across the transformer output terminals.

4.3.2.5 Battery Charger Subsystem

Integer/Fractional Keypad Instruments

The battery charger subsystem consists of components mounted on the power supply board (see Figure 4-10). The circuit utilizes a switching regulator concept based on the UC2524A (U1) regulator chip. Unregulated AC voltage is rectified

PC-1

through the diode bridge (CR1-CR4). The unregulated DC output from the rectifier bridge charges capacitor C2. C2 provides filtered DC voltage to the regulator chip and the switching circuit which consists of transistors Q3 - Q5 and Q7. When Q7 is "On", power flows through inductor (L1). As the current through the inductor builds, the regulator senses the control voltage limit and turns off the switching circuit. The collapsing field in the inductor supplies voltage to charge capacitor C6. C6 output is supplied directly to the battery. The charger output is monitored by a circuit consisting of Q6 and R14, in an over voltage condition, Q1 is turned off to shut down the regulator chip. Charger input over voltage protection is provided for the regulator chip by the circuit containing Q1, Q2, R2, R3 C1 and CR16. If input voltage is too high, the base of Q1 is turned off and the chip is shutdown.

Titration Keypad Instruments

The battery charger consists of components mounted on the power supply board. The circuit utilizes a switching regulator concept based on the UC2524A (U1) regulator chip. Unregulated AC voltage is rectified through the diode bridge (CR1, CR2, CR3, CR4). The unregulated DC output from the rectifier bridge charges capacitor C2. C2 provides filtered DC voltage to the regulator chip and the switching circuit consisting of Q3, Q4, and Q7.

Battery charger output is reduced by the resistor divider consisting of R22, R15 and R16 and then applied to U1-1. U1 compares this voltage against a 5 volt reference voltage at U1-2 and adjusts the duty cycle of U1-12 and U1-13, when these two voltages are unequal. This variable duty cycle is level shifted through Q3, Q4, and Q5 and applied to the gate of FET Q7. This results in Q4 having a duty cycle equal to that on U3-12/13. The voltage input to L1 is approximately a 40 volts p-p square wave at a switching frequency of ≈ 25 KHz. The AC component is filtered out by the L1/C5 low pass filter and is applied to the battery.

Charger output is monitored by a circuit consisting of Q6, Q23, Q13 and R14. When the battery voltage exceeds ≈ 7.8 volts, the voltage at the divider consisting of R13 and R14 exceeds the reference voltage of Q6 (2.5 VDC). When this occurs, the output of Q6 begins to draw current

thus turning on transistor Q23. Turning on Q23 turns on the gate of scr Q22 via R67 and R68. This has the effect turning on Q22 and shorting out the rectified voltage supply. While the short is applied, large currents are drawn from the transformer thus blowing the primary fuse and disabling the charger completely.

Battery current is monitored by U1 and limited to ≈ 2 amps by adjusting the duty cycle of FET Q7 as discussed above. Battery current is sensed by R8 and applied differentially to U1-5 and U1-4 offset by divider R24 and R55. When this voltage exceeds 0.2 VDC, U1 reduces the duty cycle to yield a current limit of ≈ 2 amps.

Battery voltage is adjusted by R22 to produce an output voltage of 6.9 VDC when the battery current is below ≈ 300 mA. Battery current is monitored by another amplifier in U2 via the voltage drop across R57. When the battery current exceeds ≈ 500 mA, the output of U2 switches low thus connecting R60 in parallel with R16. This has the effect of increasing the charger output voltage to 7.4 VDC. This dual state charging feature allows rapid and complete charging of the battery when needed and then switch back to the 6.9 VDC level as a float level to prolong battery life.

4.3.2.5a Dual State Battery Charger (Charger Adapter CCA)

The charger adapter board (see Figure 4-8a) works in conjunction with the Figure 4-10 battery charger circuit as modified for the dual state charger. Battery current is monitored by U1 (adapter board) by evaluating the voltage drop across R3. When the battery current is lower than ≈ 300 mA, U1 switches to an open drain state, disconnecting R1 from its parallel connection with R16 (Power Supply Board). This causes charger output voltage to switch from 7.4 to 6.9 volts. This dual state charging feature provides rapid charging using 7.4 volts, when needed, and then switches to 6.9 volts to prolong battery life during battery float conditions.

4.3.2.5b Dual State Battery Charger (-7023 Power Supply Board)

The battery charger subsystem consists of components mounted on the power supply board

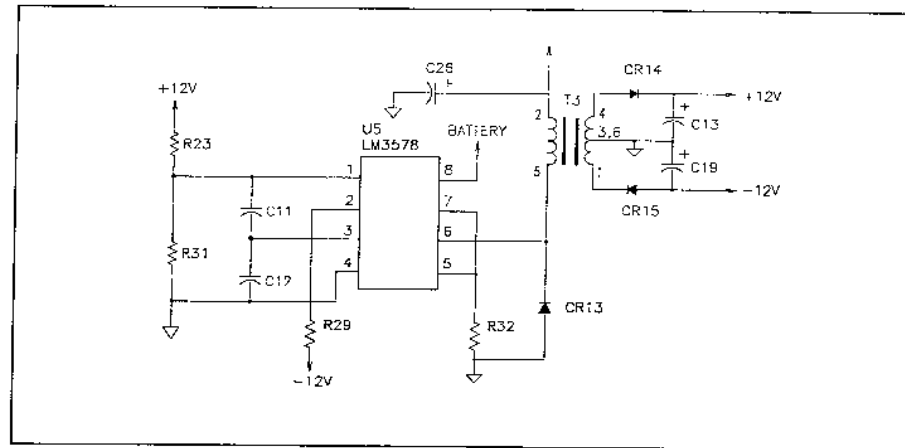

Figure 4-8. ±12 Volt Power Supply Functional Schematic [v2.xx/5.xx/6.xx]

(see Figure 4-10a). The circuit utilizes a switching regulator concept based on the UC2524A (U1) regulator chip. Unregulated AC voltage is rectified through the diode bridge (CR1-CR4). The unregulated DC output from the rectifier bridge charges capacitor C2. C2 provides filtered DC voltage to the regulator chip and the switching circuit consisting of transistors Q3 - Q5 and Q7.

Battery charger output voltage is reduced by resistor series R22, R15 and R16 and then applied to U1-1. U1 compares this voltage against a 5V reference voltage at U1-2 and adjusts the duty cycle of U1-12 and U1-13, when these two voltage levels are unequal. This variable duty cycle drive is level shifted through Q3, 4 and 5 and applied to the gate of the FET (Q7). This results in Q7 having

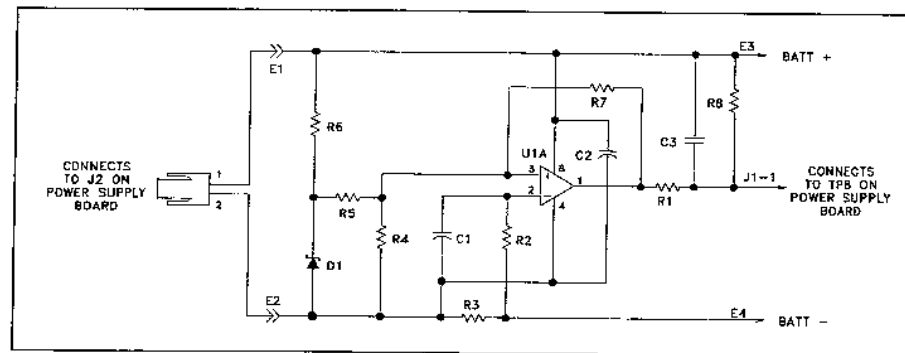

Figure 4-8a. Charger Adapter Board Schematic (with Mod Kit P/N 1310-1901-1 installed)

PC-1

a duty cycle equal to that on U1-12/13. The voltage input to L1 is approximately a 35 volt p-p square wave at a switching frequency of ≈ 25 KHz. The AC component is filtered out by the L1/C6 low pass filter and is applied to the battery.

Charger output voltage is monitored by a circuit consisting of Q6, R13 and R14. In an over voltage condition, Q1 is turned off to shut down the regulator chip. Input over-voltage protection is provided for the regulator chip by the Q1, Q2, R2, R3, R4 and C1 circuitry. If input voltage is too high, the base of Q1 is clamped by Q2 to limit the voltage applied to U1-15 to a safe level. Battery current is monitored by U1 and limited to < 2 amps by adjusting the duty cycle of the FET (Q7) as discussed above. When the battery current is > 2 amps, the voltage differential between U1-4 and U1-5 will be > 0.2 V, causing U1 to reduce the duty cycle at U1-12/13 to yield a current limit of 1.70 to 2.20 amps.

Potentiometer R22 is adjusted during manufacturing functional testing to produce a charging voltage of 7.4 volts under load. Battery current is monitored by U2 by evaluating the voltage drop across R57. When the battery current is lower than ≈ 300 mA, U2-1 switches to an open drain state, disconnecting R60 from its parallel connection with R16 and causing charger output voltage to switch from 7.4 to 6.9 volts. The dual state charging feature allows rapid charging at 7.4 volts, when needed, and a switch to 6.9 volts to prolong battery life during battery float conditions.

4.3.2.6 System Reset Circuit

Integer/Fractional Keypad Instruments

The system reset circuit shown in figure 4-9 provides a system for the microprocessor and display board via the EPLD and protects RAM data during Power On and Power Off cycles. With the relay battery open, the output at U16, pin #1 is low. When relay battery is applied to U16, pin #3, the output at pin #1 goes high after the time delay established by R43, R54 and C47. This signal is AND gated with INT0 (watchdog) from the display processor in U8. U8, pin #5 outputs a reset signal to the microprocessor and the EPLD. The Power On reset is gated within the EPLD with the Delay signal from the RC time constant circuit providing

the Display Board with a Power On reset. The Power On reset is inhibited by a delay input for 500 msec after power on. This prevents the display processor from resetting itself in the event of a display processor-generated watchdog signal.

Titration Keypad Instruments

The system reset circuit shown on Figure 4-24 sheet 2 provides a Power On reset for the microprocessor and display board and protects RAM data during Power On and Power Off cycles. With the relay battery open, the output at U9, pin #1 is low. When 5 volts is applied to U9, pin #3, the output at pin #1 goes high after the time delay established by R16, R17 and C23 providing the Display Board and Logic Board with a Power On reset. The Power On reset has a duration of approximately 180 ms.

4.3.2.7 Battery Depleted Circuit

Integer/Fractional Keypad Instruments

The Low Battery detection subsystem consists of a comparator circuit and the Op-amp U16 (see Figure 4-7). A voltage threshold is established by R27 and R55. When battery voltage crosses the threshold, the Op-amp output changes from a low to a high and a power down signal is sent to the EPLD (U5), pin #35. The EPLD outputs a low on pin 9 (see Figures 4-6 and 4-10) which shuts off Q10 and opens relay K1.

Titration Keypad Instruments

The Low Battery detection subsystem consists of a comparator circuit and the Op-amp U9 (see Figure 4-24 sheet 2 1310-5026). A voltage threshold is established by R50 and R44. When battery voltage crosses the threshold the Op-amp output changes from a low to a high and a power down signal is sent to the EPLD (U5), pin #33. The EPLD outputs a low on pin 8 which shuts off Q9 (Power Supply Board) and opens relay K1. R14 and R21 (Logic Board) provide 1 volt of hysteresis to compensate for surface charge in the battery when the load is removed.

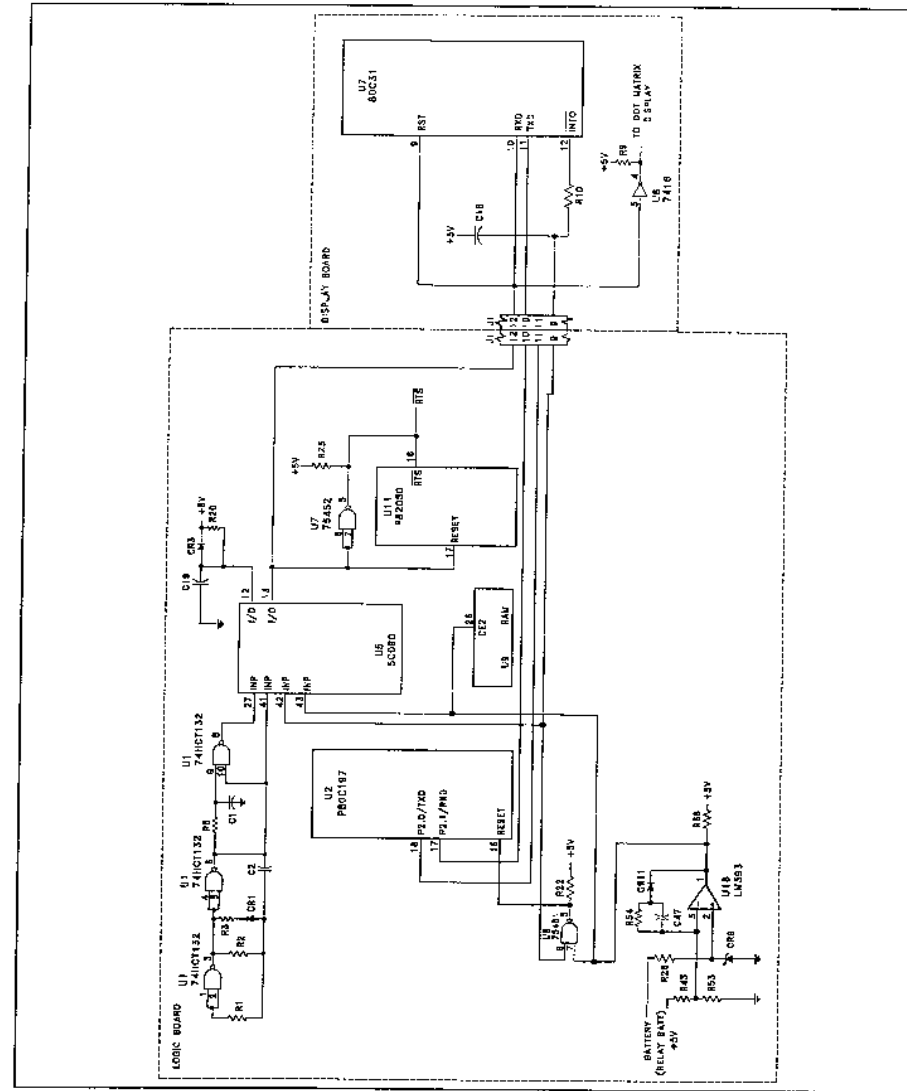

Figure 4-9. System Reset Functional Schematic [v2.xx/5.xx/6.xx]

PC-1

4.3.2.8 Pumping Mechanism

The pumping mechanism employs a hybrid stepper motor to provide the torque to turn the camshaft and operate the pumping fingers. A microprocessor based motor control circuit (see Figure 4-11) is used to generate the motor operating pulses. The hybrid motor employs a multi-toothed rotor and stator with an axially magnetized concentric magnet mounted on the rotor shaft. The teeth on the iron cups attached to the opposite ends of the concentric, permanent magnet are offset from each other one half tooth pitch. The rotor to stator tooth ratio is 50:48. This provides 7.5° stator and 7.2° rotor inter-tooth spacing. The 0.3° differential across a six stator tooth span (45° of arc) provides a 1.8° rotor to stator offset. The stator is wound in a four-pole four-phase configuration. Stator polarity changes 45° as each of the four phases is sequentially energized (see Figure 4-12).

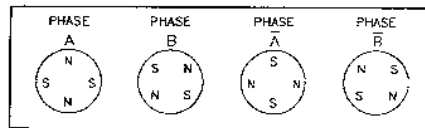

Figure 4-10. Stator Polarity Change as a Function of Phase Excitation.

The positional relationship between the central tooth on a stator pole and the rotor is shown with the A phase energized in Figure 4-13.

When the B phase is energized and the stator polarity changes 45°, the rotor turns to align teeth 7/7° and 32°/31, a 1.8° rotation. Rotational realignment occurs as each motor winding phase is sequentially energized and the stator polarity changes 45° clockwise. This stepper motor configuration provides 200 incremental motor steps per revolution. The pumping mechanism electrical interface utilizes dual phase excitation and a unipolar, current limited driver. Figure 4-14 depicts the input signal pulses and change in phase excitation of a unipolar driver.

Motor drive current is initially supplied at 500 mA minimum for 5 msec; then it is allowed to decay over a 10 msec time constant to 170 mA minimum where it remains until the next step is commanded. The motor drive frequency range of operation is

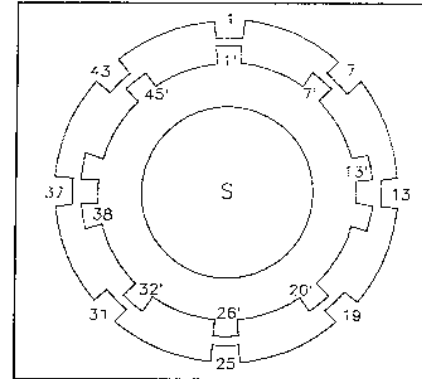
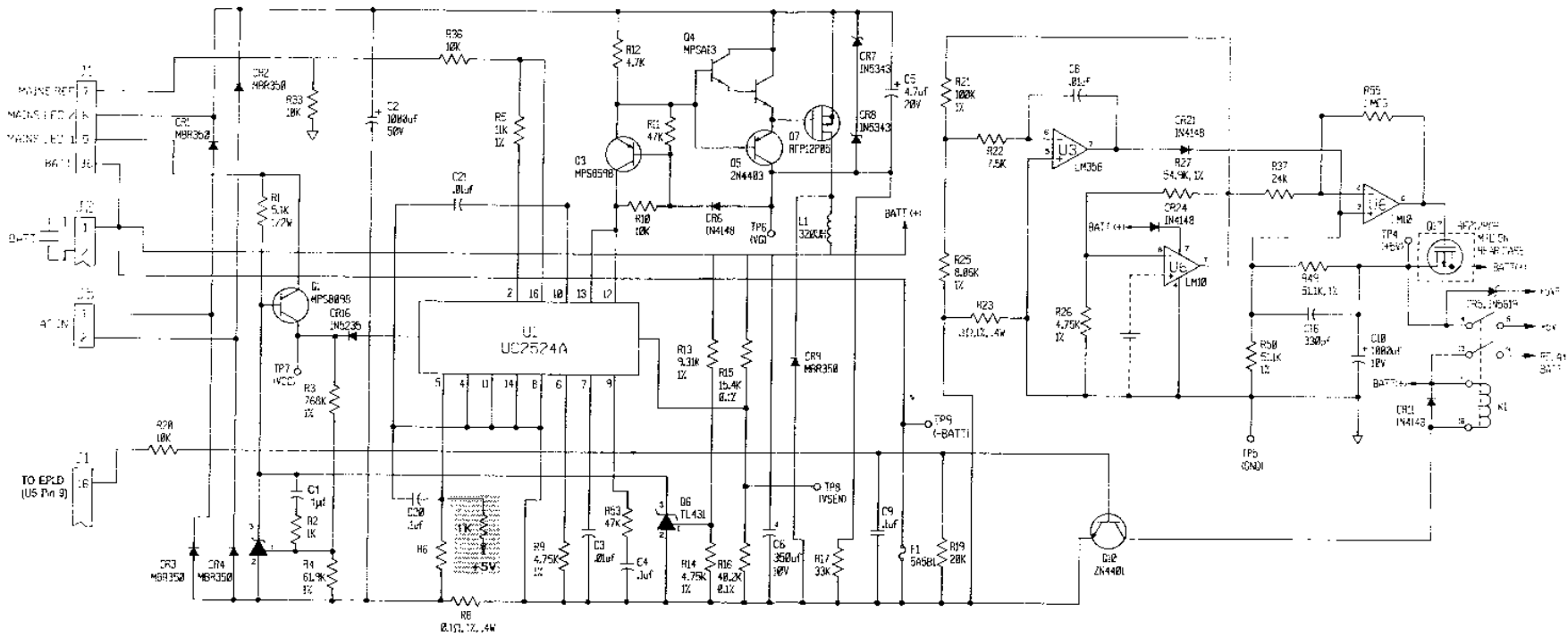

Figure 4-11. Relationship of Stator and Rotor Teeth with the A Phase Energized.

between 0.05 and 333 Hz. The nominal motor drive frequency is a function of the instrument's programmed infusion rate. This rate is software modulated to provide inter-step timing that will yield a linear fluid flow pattern. Software can also increase the nominal rate as much as 10% to compensate for periods of *low flow*. To initiate a motor step, the microprocessor provides a phase designated signal to the quad FET (U18). Simultaneously, the processor activates the base of Q1 to provide motor drive current through Q16. Software controls the pulse width of the step signal at 3 msec. When Q1 turns off, voltage at U17, pin #6 degrades to 0.5 VDC over a 10 msec time constant (established by R56 and C30) and is then held at the reference level determined by U17 pin #5. These two voltage levels result in the current being controlled at 500 mA to turn the motor and 170 mA to dampen and hold the motor in the new position. Diodes CR12 through 15 protect the motor driver from feedback of induced current.

The microprocessor monitors the signal from the motion sensor comparing it with the output to the motor driver as a rate accuracy check.



This component installed in conjunction with the Dual State Charger Modification Kit P/N 1310-1901-1

Figure 4-12. Battery Charger Functional Schematic (without Dual State Charger)

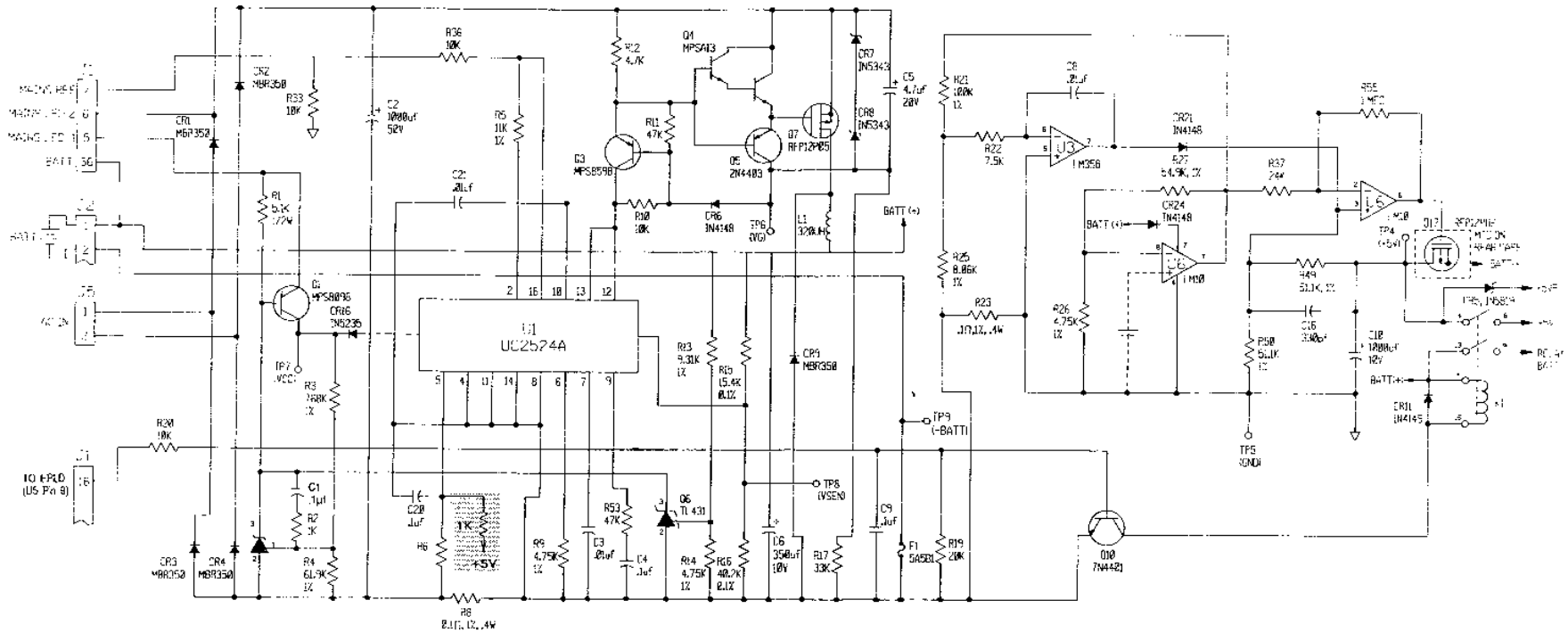

This component installed in conjunction with the Dual State Charger Modification Kit P/N 1310-1901-1

Figure 4-12. Battery Charger Functional Schematic (without Dual State Charger)

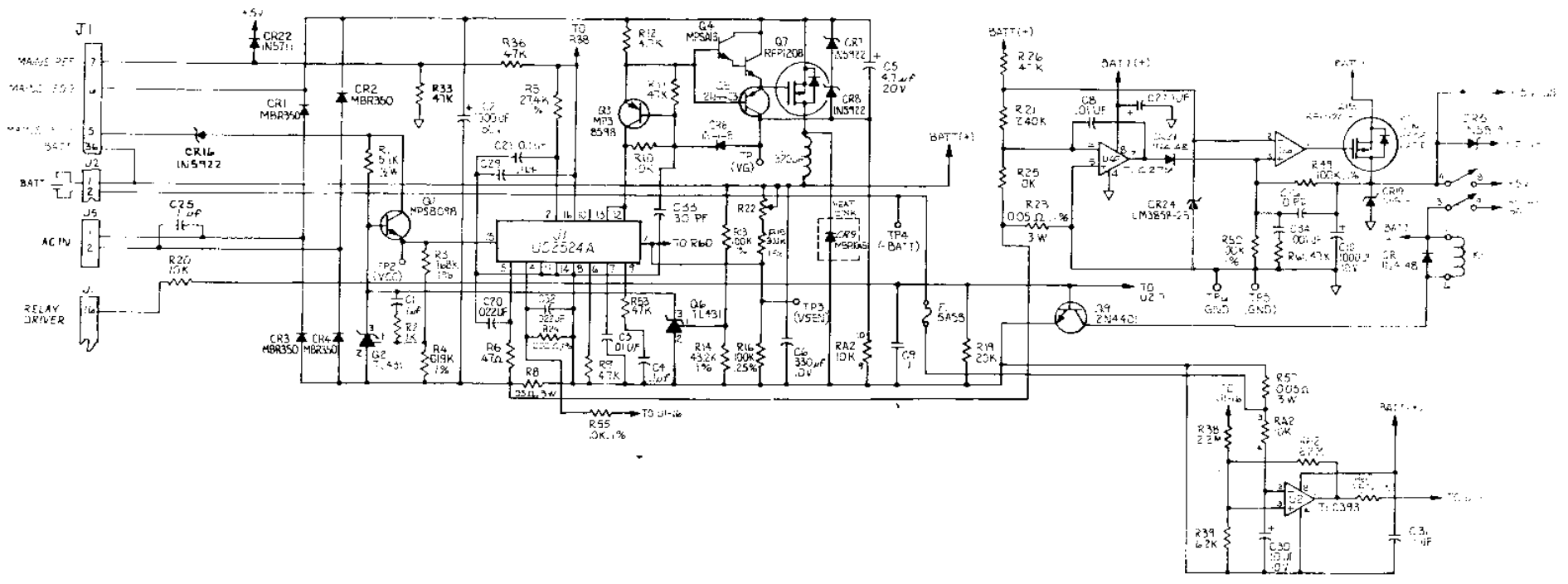

Figure 4-12a. Battery Charger Functional Schematic
1310-7023 Power Supply Board (Dual State Charger)

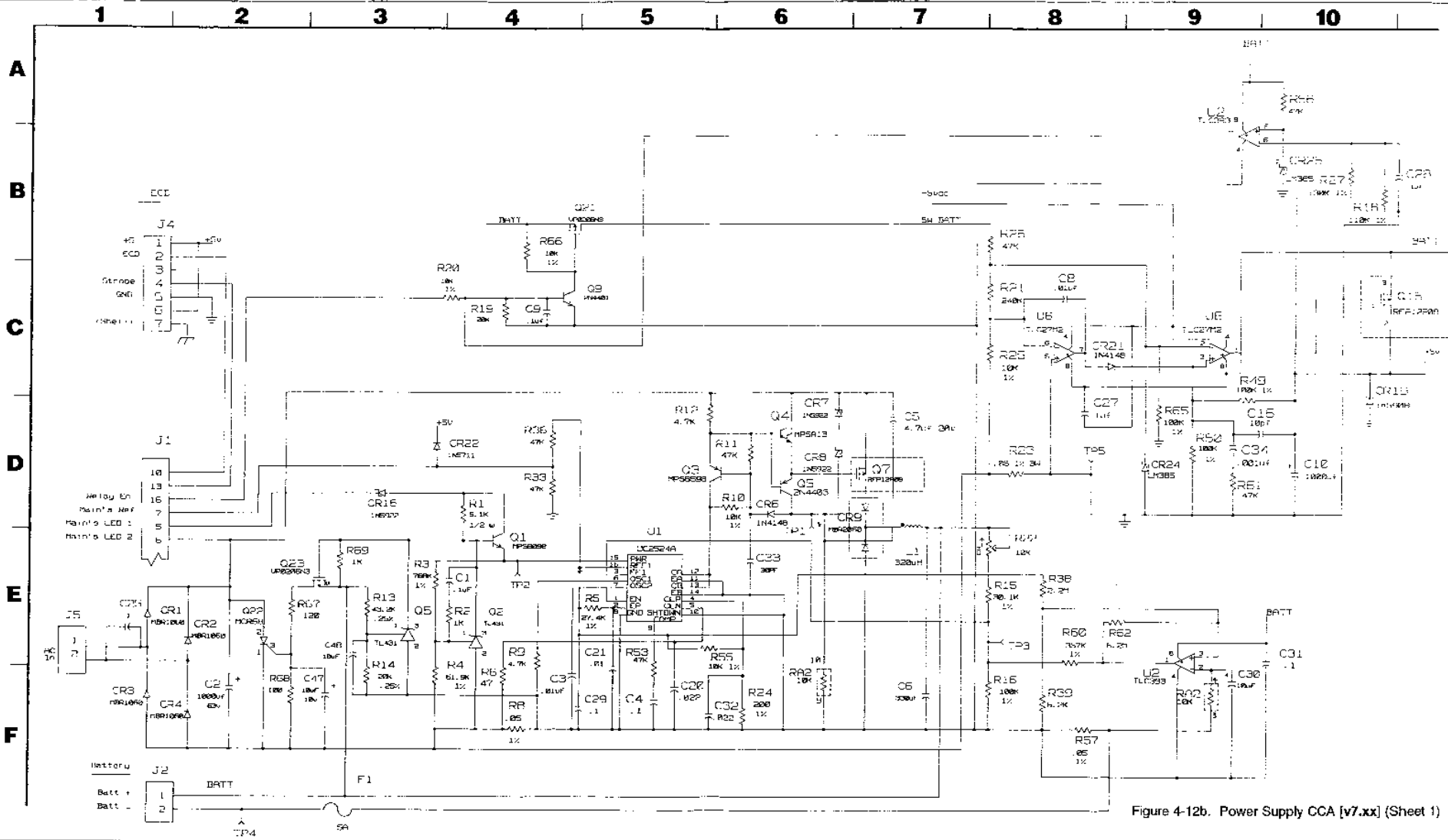

Figure 4-12b. Power Supply CCA [v7.xx] (Sheet 1)

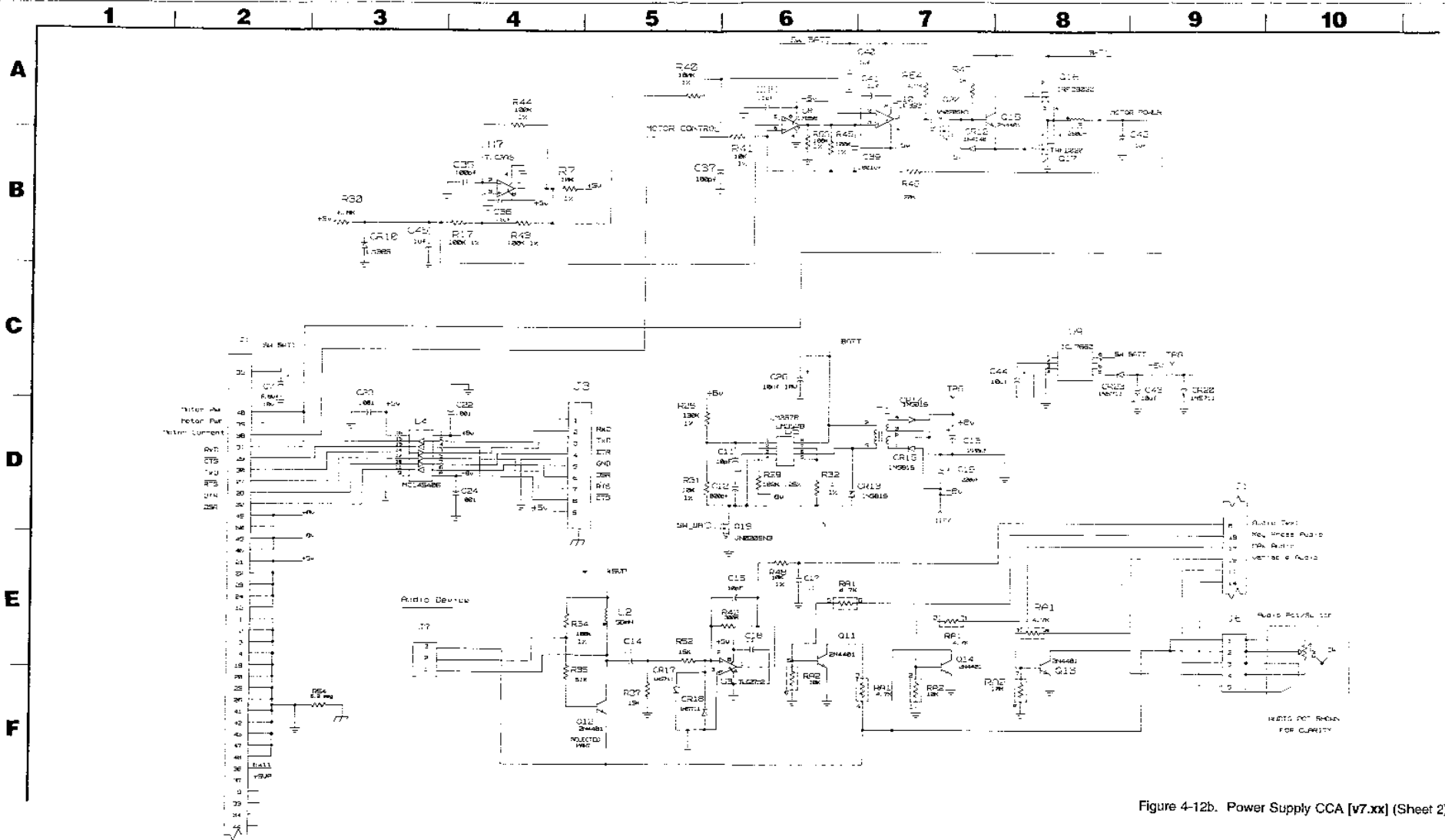

Figure 4-12b. Power Supply CCA [v7.xx] (Sheet 2)

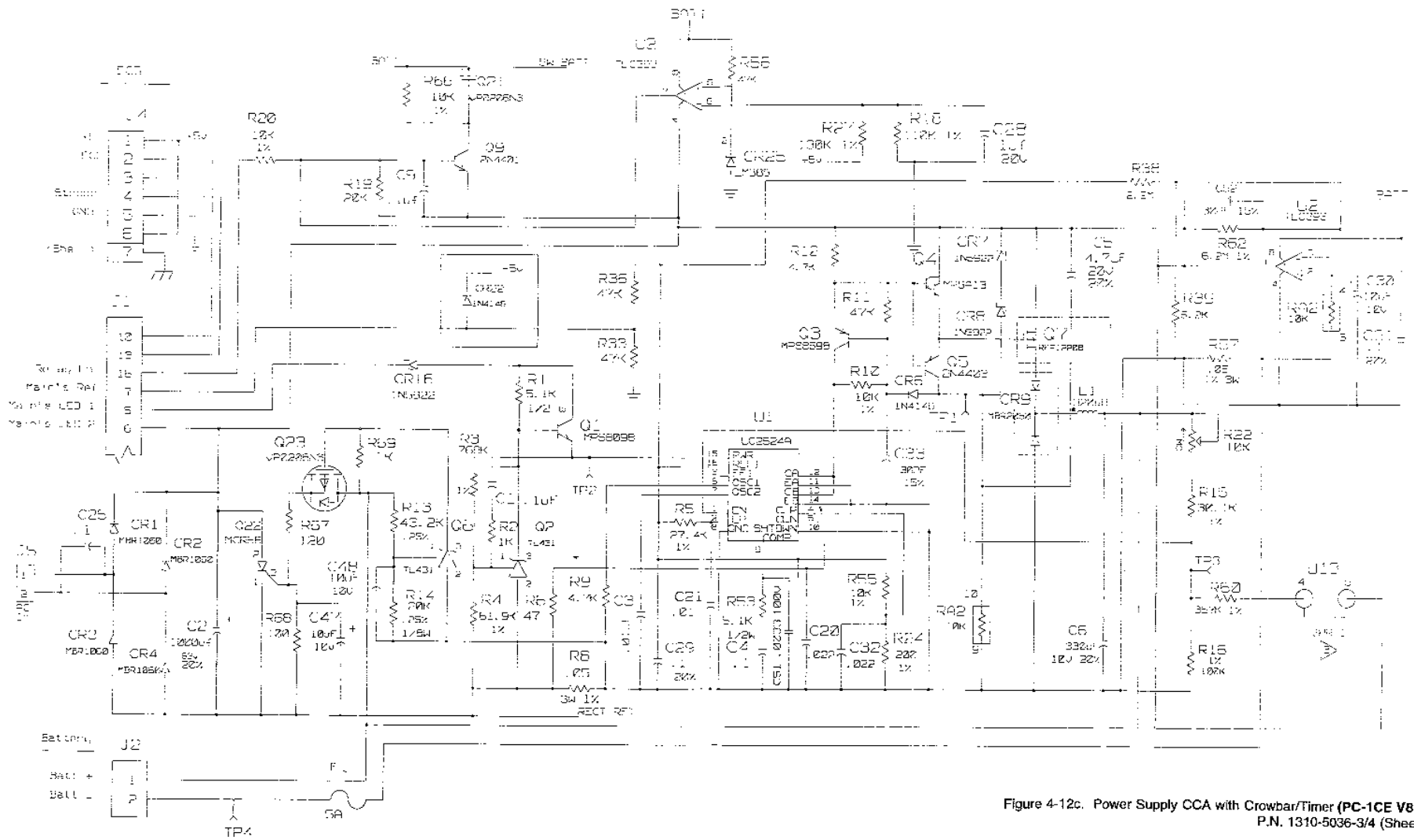

Figure 4-12c. Power Supply CCA with Crowbar/Timer (PC-1CE V8.xx)
P.N. 1310-5036-3/4 (Sheet 1)

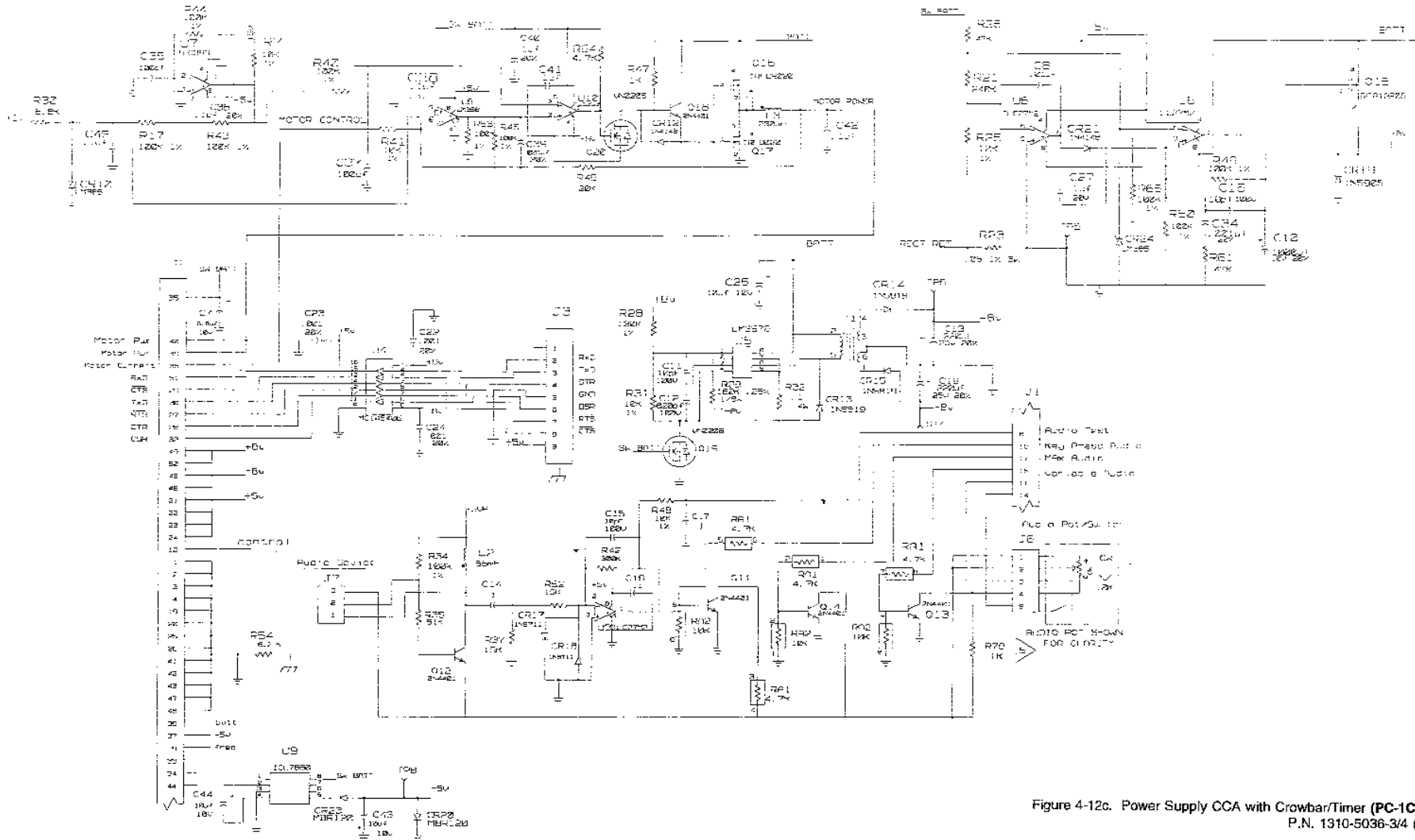

Figure 4-12c. Power Supply CCA with Crowbar/Timer (PC-1CE V8.xx)
P.N. 1310-5036-3/4 (Sheet 2)

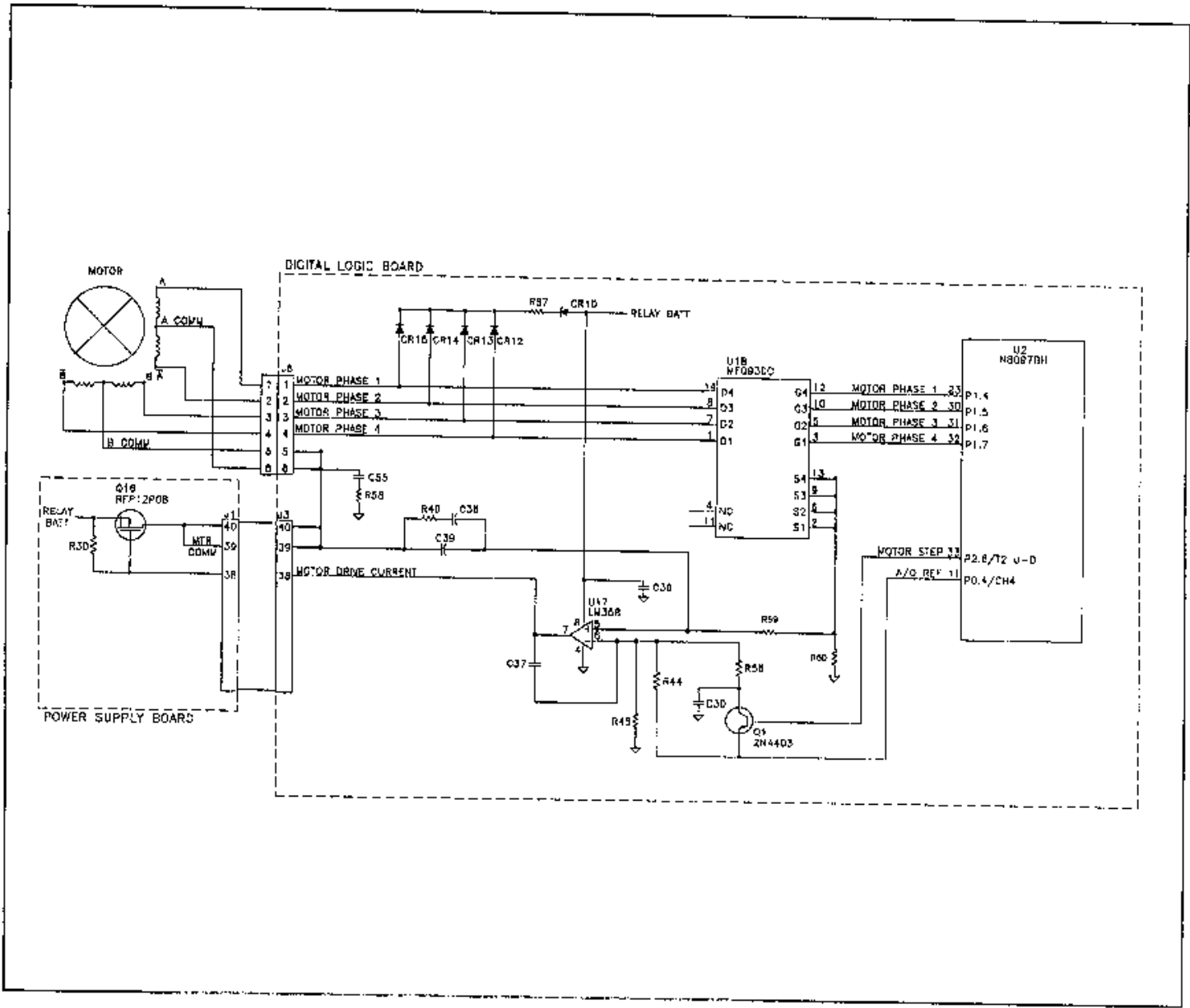

Figure 4-13. Pumping Mechanism Functional Schematic [v2.xx/v5.xx/v6.xx]

PC-1

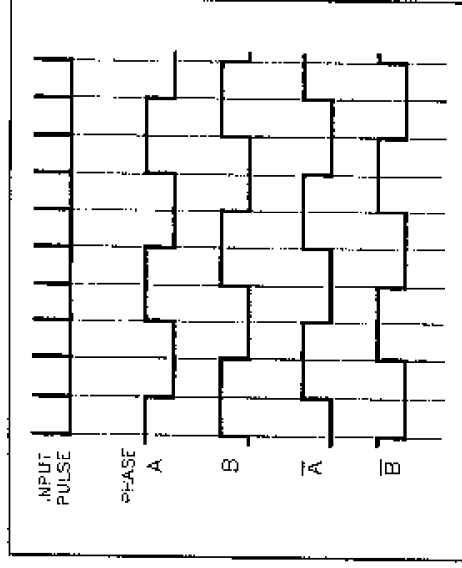

Figure 4-14. Input Signal Pulses and Change in Phase Excitation of Unipolar Drive.

Titration Keypad Instruments

The chopper drive circuits provide an efficient means of converting the battery voltage to a lower variable voltage required by the stepper motors. These circuits are another form of switching regulator made up from discrete components.

A 50 KHz oscillator is formed by U7 and associated components. The output at U7-1 is a 50 KHz, 0 to 5 volt square wave. When applied to the RC network (R40, C37), a triangular waveform is produced and applied to comparator U10-2. When the control signal at R41 is decreased or increased, the output at U8-7 is increased or decreased respectively. When applied to U10-3 and compared to U10-2, the output at U10-1 will be a 50 KHz variable duty cycle waveform. This waveform is level shifted via Q20, Q18 and applied to the gates of Q16 and Q17. The result is a variable duty cycle waveform at the drains of Q16 and Q17. When filtered by L3 and C42, a filtered voltage is produced inversely proportional to the voltage applied to the control input. When combined with the error amplifier located on the logic board, and the loop closed around the stepper motor, a constant current drive is the result.

4.3.2.9 Strain Beam

The PC-1 pump/controller employs a strain gauge subsystem to input administration set pressures to the microprocessor through its Integral Analog to

Digital converter. The subsystem incorporates a matched resistor bridge on the pressure sensing beam and a signal conditioning circuit (see Figure 4-15). Each leg of the resistor bridge is nominally 1200Ω. The Zero Balance Specification is 0.3 mV/V_{EX}. With no load applied to the beam and 5 volts excitation, the Zero offset output will be ±1.5 mV. Application of a positive force, up to the 1 pound maximum load capacity of the strain beam, will lower the resistivity of the resistors in compression and increase the resistivity of the resistors in tension. At full deflection, the bridge will produce a 5 to 10 mV change in output voltage. The signal conditioning circuit provides amplification and offset compensation to the low level signal output by the bridge circuit.

The conditioning circuit's primary amplifier is a conventional three op-amp, balanced differential to single ended instrumentation type. The first stage uses a matched pair of op-amps for input signal tracking. The gain of this stage is determined by resistors R61, R62 and R63 in accordance with the following formula:

$$A = \frac{(R61 + R63)}{R62}$$

The following stage is a balanced differential to single ended type with a gain of 1. The output of the offset amplifier is summed with the output of the second stage of the primary amplifier through resistor R37. This provides an output at U14 pin #1 of strain beam voltage x 496 plus the offset voltage. This allows the contributions of gauge offset and pre-load associated with the pumping chamber tubing set to be balanced with one adjustment. The output of U14 Pin 1 is further amplified through a subsequent stage with a gain variable between 1 and 6. This stage incorporates a diode (CR16) between the output and the feedback divider which prevents the output from going negative. A post amplification filter consisting of R12 and C7 rolls off the gain at about 40 Hz. The diode (CR7) clamps the output voltage at V_{CC}. This signal is then supplied to the Analog input on the microprocessor for digital conversion.

The microprocessor's internal A/D converter has 10 bit resolution capability; however, in this application

PC-1

the least significant bit is discarded leaving 9 bits usable which yields a per bit resolution ratio of 1:512. Using a reference voltage set at 5 V, each bit is equal to $\frac{5}{512}$ or ≈ 9.76 mV. The strain beam calibration process involves applying known pressures and then adjusting the gain and offset (SPAN and ZERO) balance of the signal conditioner to yield set voltages. Since the converter is unipolar and will only process signals in the range of 0 to V_{REF} , the calibration points are established at 0 and 10 psi (69 kPa; 517 mmHg) which correspond to 1.5 and 4.5 volts respectively. The 10 psi (69 kPa; 517 mmHg) differential between calibration limits equates to 3.0 volts. On a 5 volt scale, this equates to using $\frac{3}{5}$ of the available scale; i.e., $\frac{3}{5}$ of the 512 bits or 307 bits. Converting psi to inches of water pressure, the 10 psi (69 kPa; 517 mmHg) differential equals 332 inches (843 cm) of water pressure. This establishes the resolution of the converter at 1.08 inches (2.74 cm) per bit. Setting the 0 psi value equal to 1.5 volts allows the system to recognize and measure pressures less than atmospheric which can occur during an upstream occlusion. In addition, the strain beam will also detect the presence of an administration set in the pumping chamber.

4.3.2.10 Air-In-Line Detector

The active elements of the PC-1's air-in-line detection system includes two piezo-electric (PE) crystals and a signal processing circuit. The PE crystals and acoustic lenses are bonded into recesses in the AIL/SCD housing (see Figure 4-16). The signal processing circuit is part of the AIL/SCD printed circuit board. Ultrasonic sensing is used for air-in-line detection since ultrasonic wave transmission is independent of fluid opacity. Ultrasonic signal transmission (acoustic impedance) through all IV compatible solutions falls within a very discrete range which is easily discernable from passage through air.

The air-in-line detector is located below the pumping mechanism and checks the integrity of the fluid column entering the patient side (distal portion) of the tubing set. The acoustic lenses and installed tubing set provide a coupling path for the continuous wave ultrasonic transmission to travel from the transmitting to the receiving crystal. When the tubing contains an IV solution, the acoustic impedance is low and maximum energy is coupled

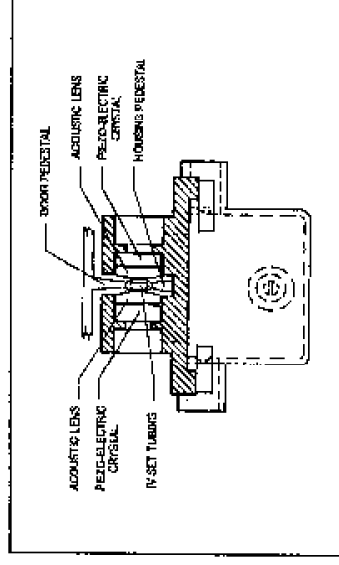
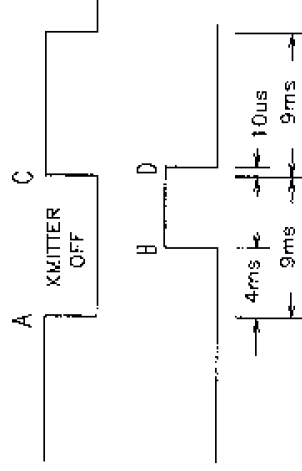

Figure 4-16. AIL Detector Cross Section

to the receiving element which generates a voltage signal that is proportional in amplitude and frequency to the coupled energy. If an air bolus is interposed between the lenses, the acoustic impedance is significantly increased as the acoustic wave is reflected by the liquid-air interface. The energy received is reduced and the voltage output is commensurately reduced. This signal differentiation combined with the instruments programmed delivery rate is used to measure the volume of the air bolus.

The AIL detector's signal processing circuit drives the transmitter and amplifies, detects and performs a threshold comparison on the received signal. The system is strobed by a software generated signal every 18 msecs to validate system operation. A filter within the circuit creates a time delay between the transmitter Off cycle and a state change in the receiver output. Because the strobe is software generated, the wave form is non-uniform. A nominal timing wave has the form depicted below:



The output of the AIL circuit is sampled just prior to the strobe changing state which yields the following truth table:

	AIR HI	AIR LO
TRANSITION A	AIR	LIQUID
TRANSITION C	CKT OK	CKT FAULT

The transition at point B always occurs approximately 4 ms later than the transition at A; however, circuit tolerances and signal levels can cause this delay to vary as much as ± 2 ms. The calculation of air bolus size is based on the assumption that at a given delivery rate air and fluid will pass through the sensor at a uniform rate. The length of time required for an air bolus to pass through the detector is measured by counting the number of timing interrupts when the sensor is "seeing" air. Time is therefore measured in number of interrupts per bolus. When the resultant time exceeds the time required for 38 motor steps, the instrument enters an "AIR IN LINE" alarm condition.

4.3.2.11 Slide Clamp Detector

The slide clamp detection subsystem consists of a photo diode and transistor plus a signal control and comparator circuit. The photo diode and transistor are mounted diametrically on the sides of the slide clamp recess on the AIL/SCD housing (see Figure 4-17). The signal processing circuitry for the slide clamp is incorporated into the AIL/SCD printed circuit board. When the slide clamp circuit is energized, a beam of light is projected across the slide clamp recess. The beam is positioned at a point where movement of the slide clamp towards "open" will interrupt the light beam just before free flow occurs in the tubing. If the light path is interrupted with the pumping chamber access door open, the instrument will enter a "FLO STOP OPEN / CLOSE DOOR" alarm condition. The photo diode is driven by the same microprocessor strobe used by the AIL detector. When the strobe is low and the optical path is not obstructed (Flo Stop closed or set not installed), current is induced in the photo-transistor which produces a high logic level signal to the microprocessor. When the optical path is obstructed (set installed and Flo Stop open), the output of the photo-transistor provides a low logic level signal to the microprocessor. By comparing the slide clamp detector circuit output resulting

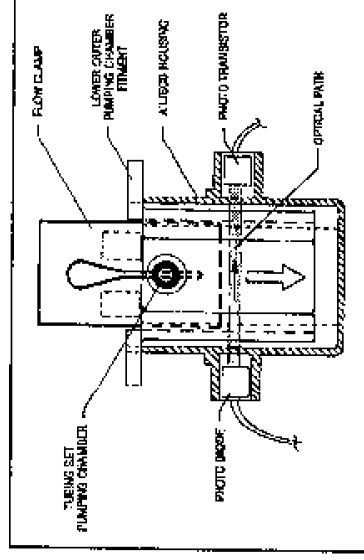

Figure 4-17. Slide Clamp Detector Cross Section

from a high strobe condition against the output from a low strobe enables the system to verify proper operation of the SCD detector. Early versions of the instrument utilize a transistor-actuated dual comparator circuit to evaluate the output of the photo-transistor (see Figure 4-18a). Later versions send the output of the photo-transistor directly to the microprocessor (see Figures 4-18b, 4-18c and 4-18d).

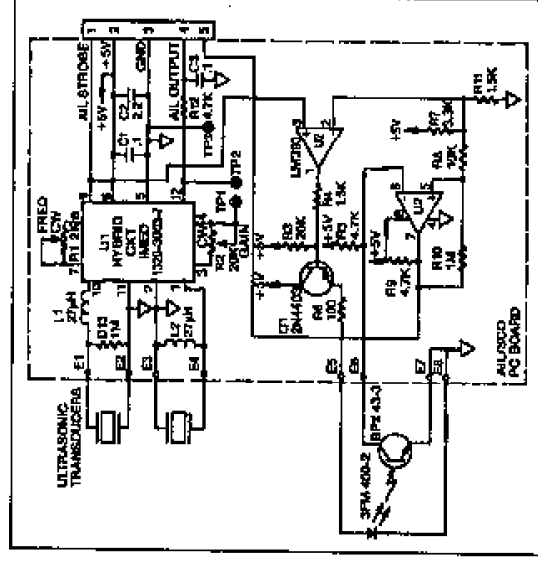

Figure 4-18a. Hybrid AIL/SCD Board Schematic

4.3.2.12 Door Sensor

The door sensor subsystem consists of a Hall Effect sensor and the logic circuitry necessary to query the sensor and to determine Open or Closed

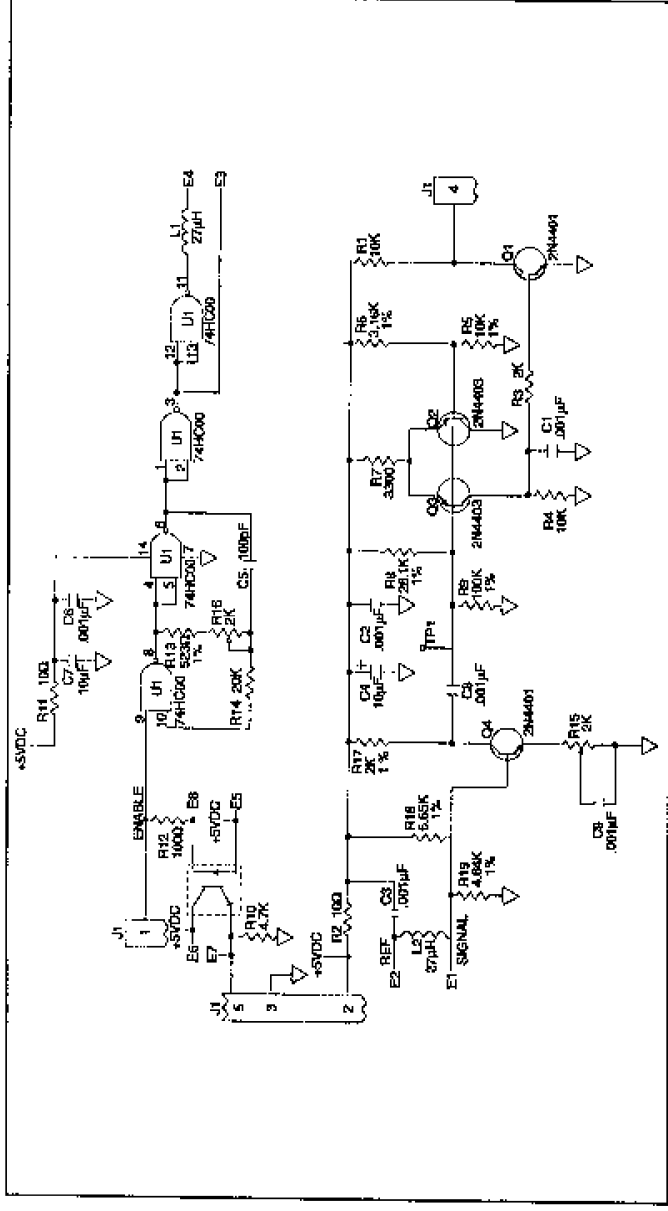

Figure 4-18b. AIL/SCD PCB Schematic (1310-5000)

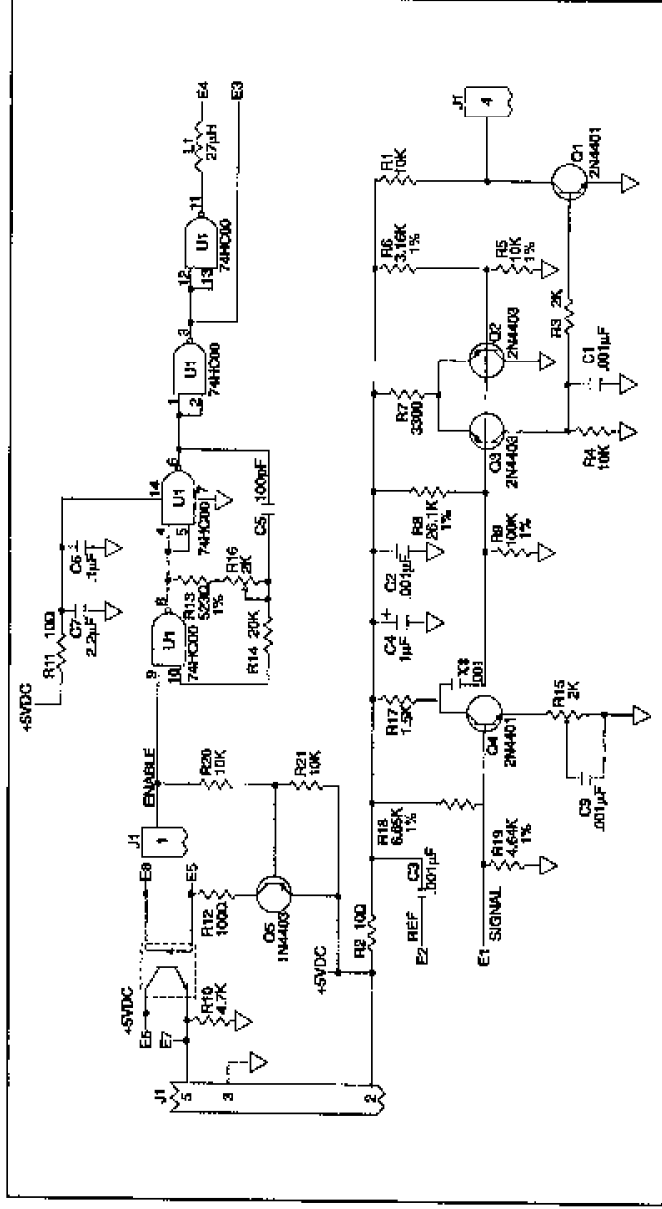

Figure 4-18c. AIL/SCD Schematic (1310-5012)

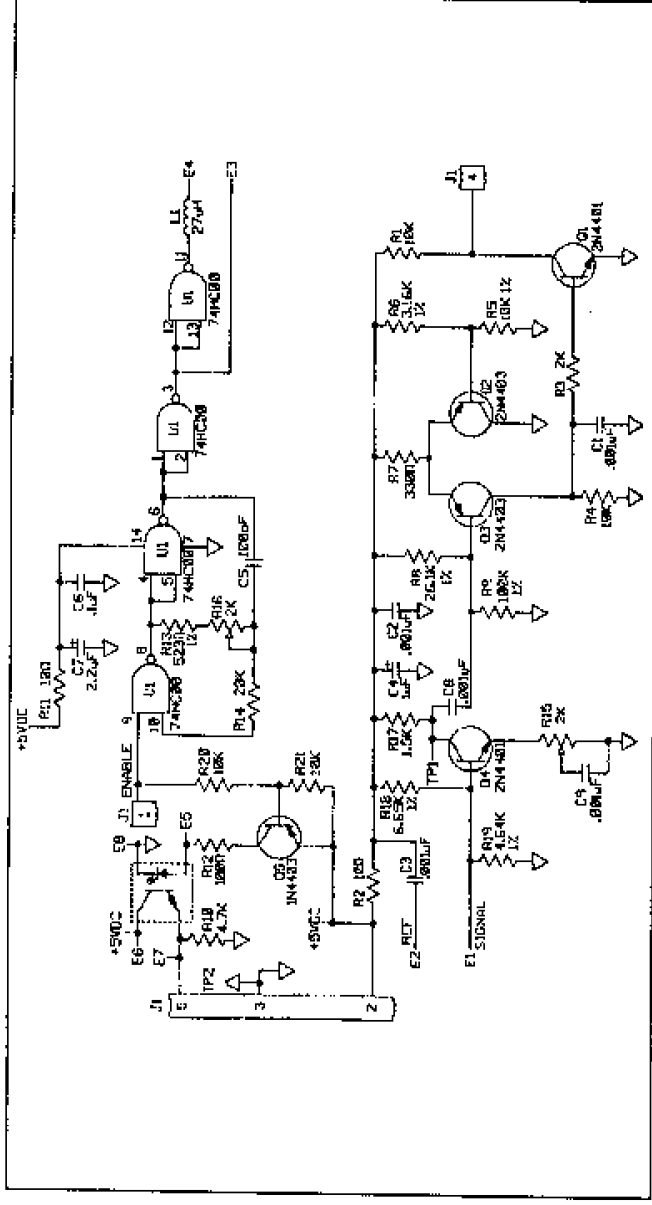

Figure 18d. AIL/SCD PCB Schematic (1310-5024)

status and report the existing condition to the processor. The Hall Effect sensors are located on the rear of the front case insert assembly 2.375 inches directly below each anchor bracket assembly (see item 50, Fig 6-2a). The magnet is attached to a pedestal on the backside of the door latch handle (see item 600, Fig 6-3). The components of the door sensor logic circuit are incorporated on the Logic PC board (see Figure 4-7). The door sensor is enabled by a strobe from the main processor through the EPLD (U5).

4.3.2.13 Audio Subsystem

The audio subsystem consists of an audio oscillator, audio system control circuitry, volume control and silence switch. The audio oscillator is mounted on the power supply board and seated against the rear case over the audio alert aperture. The system circuitry and oscillator are incorporated on the power supply board. The audio volume control is mounted on the rear panel and the silencing feature is a function of the keypad CLEAR/SILENCE control. The functional schematic for the Audio system is shown in Figure 4-19. During normal instrument operation, all audio signals are initiated by the EPLD. An audio pulse is

sent from the EPLD (U5) to the base of transistor Q11, Q14 or Q13 to produce an audio signal of the required period and intensity. Audio signals that permit volume adjustment and silencing are routed through Q13. Keypress signals are routed through Q11 and are limited in volume intensity by R45. Malfunction audio which is projected at maximum volume is routed through Q14.

4.3.2.14 Display Subsystem

The Display Subsystem consists of five subordinated elements that are interfaced and collectively make up the user interface. The Operator Information (message) display consisting of eight 5 x 7 dot matrix arrays which are capable of displaying all the upper and lower case alphabetic characters, numbers 0 - 9 plus ?, (,), = and /. The dot matrix display is an intelligent device containing an oscillator for the scan clock, the system interface logic, the character decoding logic and the display drivers (see Figure 4-20). The selected scan frequency prevents visual detection of flicker. The message arrays interface with the logic system controller bus. The interface includes the lower eight bits of the data bus, AD0 to AD7.

PC-1

six address lines A0 to A5 plus logic enable and a negative reset signal with a 50 msec pulse width.

The RATE and VTBI displays each consist of four 7-segment, common cathode LEDs with the decimal point option and include a control circuit for segment error detection. The common cathode of each digit display is connected to a digit driver (U4). The character driver (U2) determines the numeral to be displayed. The driver ICs are internally latched and are interfaced to the display microcontroller (U7) bus. The microcontroller multiplexes the displays at a minimum scan rate of 60 Hz which prevents visual detection of display flicker. The error check circuit is controlled by the processor (U7). The error check routine runs concurrently with display scanning. Every segment is tested each time a digit is enabled. The processor selects the individual segments by outputting a code on port #1 which enables one of 8 switches in an analog demultiplexer. This output is sampled by a window comparator (U3) which converts the analog signal to a logic level to be analyzed by the processor. The interface is comprised of the lower eight bits of the data bus, AD0 - AD7; four decoded address lines, A0 - A2

plus logic enable; two data strobes; write; read and system reset. The display processor U7 provides scanning, formatting and outputs characters through port 1 and segment control through port 2. Reset signal is negative true. The control logic detects failures in the LED segments and drive circuitry due to shorts or opens and reports the condition to the logic subsystem. Figure 4-20 includes the functional schematic for the Segment Check/Error Detection circuitry.

The instrument also employs 6 discrete LEDs that are incorporated into the rate and VTBI display matrix and occupy the positions of the display's unused decimal points. These LEDs display the status of user interface selections and instrument operating status. Five of the LEDs are controlled by the display processor (U7). Two of these are used for the Delivery mode/Operating indicators, one is used to indicate the selection and status of a Secondary infusion, one indicates operation on battery power and the last operates in conjunction with the communication subsystem. The AC connected indicator interfaces directly with the power supply subsystem. The keypad is interfaced

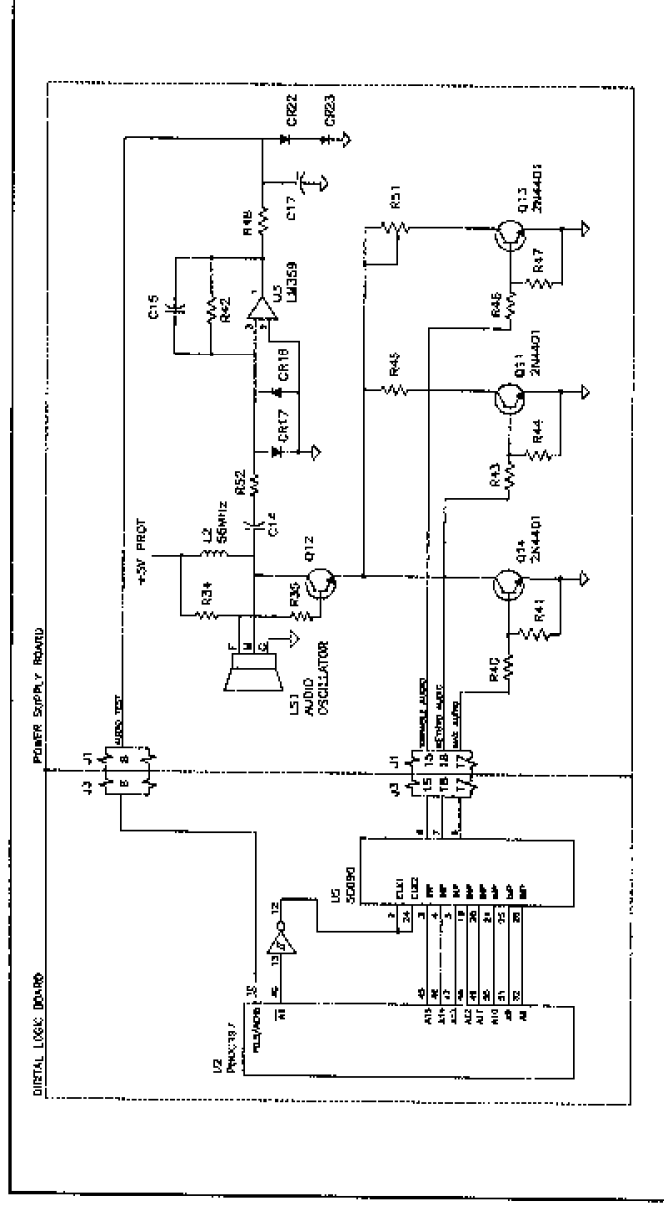

Figure 4-19. PC-1 Audio Subsystem [v2.xx/5.xx/6.xx]

PC-1

to the display microcontroller's I/O port as a 4x4 key matrix. Keyboard scanning, key debouncing and decoding is accomplished by software in the display controller except for the Power On key which is interfaced to logic on the digital logic board. Two LED light bars and one discrete indicator lamps are provided for use with the serial interface when the PC-1 pump/controller is connected to a host computer system. The COMPUTER CONTROL and MONITOR indicators are LED back-lights and indicate the computer mode selection. The discrete LED flashes when communication traffic is active.

4.3.2.15 Communications Interface and Signal Definitions

The PC-1 pump/controller can be interfaced with a host computer by using a cable configured with a 9-pin 'D' subminiature male connector with either a quick release or screwlock backshell for mechanical interconnection. Figure 4-21 illustrates the circuit for the RS-232-C Communications Data Port connector. Signal voltage levels are ± 12 VDC at 20 mA. Signal characteristics conform to RS-232-C Standards. Pin #5 of the Communications Data Port connector is connected to logic ground on the communications board and is only to be used for

common signal return for TXD, RxD, DTR, DSR, RTS and CTS. Pin #1 of the Data Port connector is not connected and is to be used only for protective shielding of the interface cable. The interface cable shield should only be attached to chassis ground on the host computer end of the cable. Pin #9 is not connected and should not be used. Table 4-1 defines the signals and identifies the pin numbers used to interface a host computer to the PC-1 pump/controller. The instrument utilizes IED C2 Communications Protocol which can be found in the C-2 Programmers Guide P/N 1320-9004.

NOTE

Maximum leakage current to chassis ground from connected peripheral equipment must not exceed 100A.

4.3.2.16 Maintenance Mode

The maintenance mode subsystem operation is activated when the COMPUTER CONTROL MONITOR switch is pressed and held during instrument power up. Once enabled, Maintenance Mode operation is strictly software dependent.

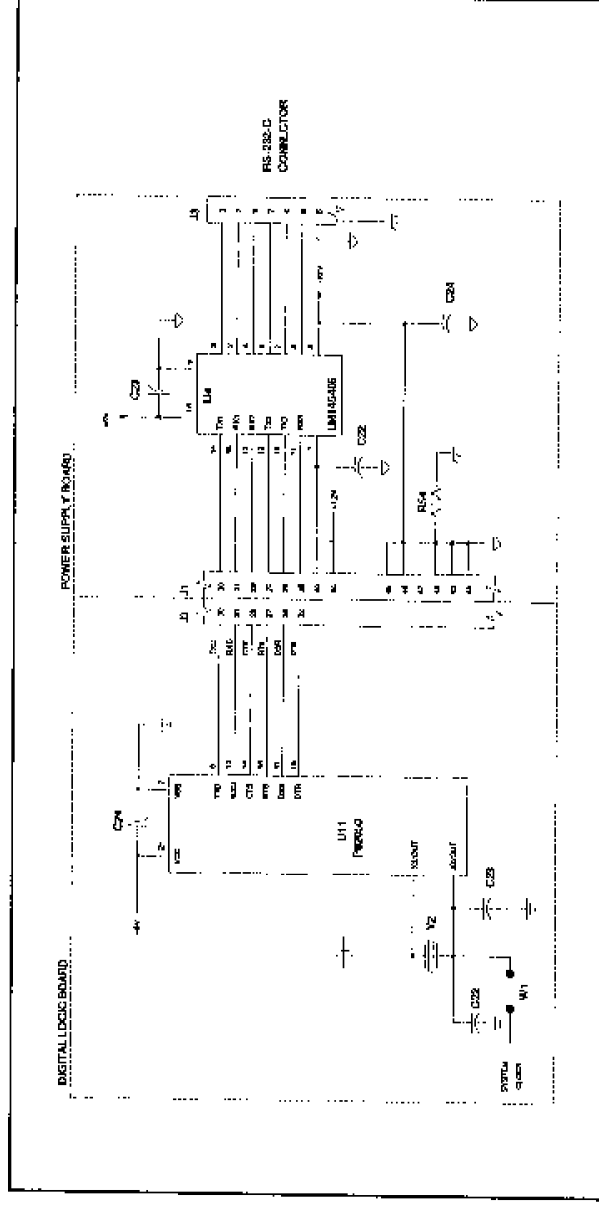

Figure 4-21. Communications Interface Functional Schematic

PC-1

Table 4-1. RS-232-C Communications Data Port Signal Definitions

Signal Name	Number	Direction	Definition
GND (Ground)	1	Host	Not tied to chassis ground on the PC-1 pump/controller. To be used only for protective shielding. The shield should only be connected to chassis ground on the host computer end.
TxD (Transmit Data)	3	PC-1 to Host	Serial data transmitted to host computer from PC-1.
RxD (Receive Data)	2	Host to PC-1	Serial data transmitted to PC-1 from host computer.
RTS (Request to Send)	7	PC-1 to Host	When asserted, RTS indicates to the host computer that the PC-1 has information to transmit. Can be used to tell the host computer to wait.
CTS (Clear to Send)	8	Host to PC-1	Asserted by the host computer to enable the PC-1 to transmit data.
DSR (Data Set Ready)	6	Host to PC-1	DSR indicates to the PC-1 that the host computer is capable of communications. (Connected and power on).
Signal Ground	5	PC-1 to Host	Common signal return to TxD, RxD, DTR, DSR, RTS and CTS.
DTR (Data Terminal Ready)	4	PC-1 to Host	DTR indicates to the host computer that the PC-1 is capable of communication. (Connected and power on).
Not Connected	9		

4.3.2.17 All except V8.xx. Empty Container Detector (ECD)

The Empty Container Detector subsystem consists of an optical sensor with a signal amplifier and a signal conditioning circuit. The optical sensor and amplifier circuit are molded into the ECD assembly which attaches to the drip chamber of a primary administration set. The signal conditioning circuitry is incorporated internally on the ECD's printed circuit board. The microprocessor generates an ECD strobe to query the optical sensor. The strobe has the same duty cycle as the strobe used with the AIL detector subsystem (see section 4.3.2.2). Without an ECD connected, the signal to the

processor will always be read as a high. With an ECD connected and fluid in the drip chamber the light beam is refracted, interrupting the optical path to the photo transistor and the ECD output signal is an inverted strobe signal which is read by the processor as a high. The detector's signal conditioning circuit (see figure 4-22) uses a synchronous demodulator to minimize spurious signals resulting from ambient light reception. When the drip chamber empties, synchronous pulsed light is sensed by the photo transistor and the ECD output signal goes high. This signal is read by the processor which issues an EMPTY CONTAINER-KVO advisory.

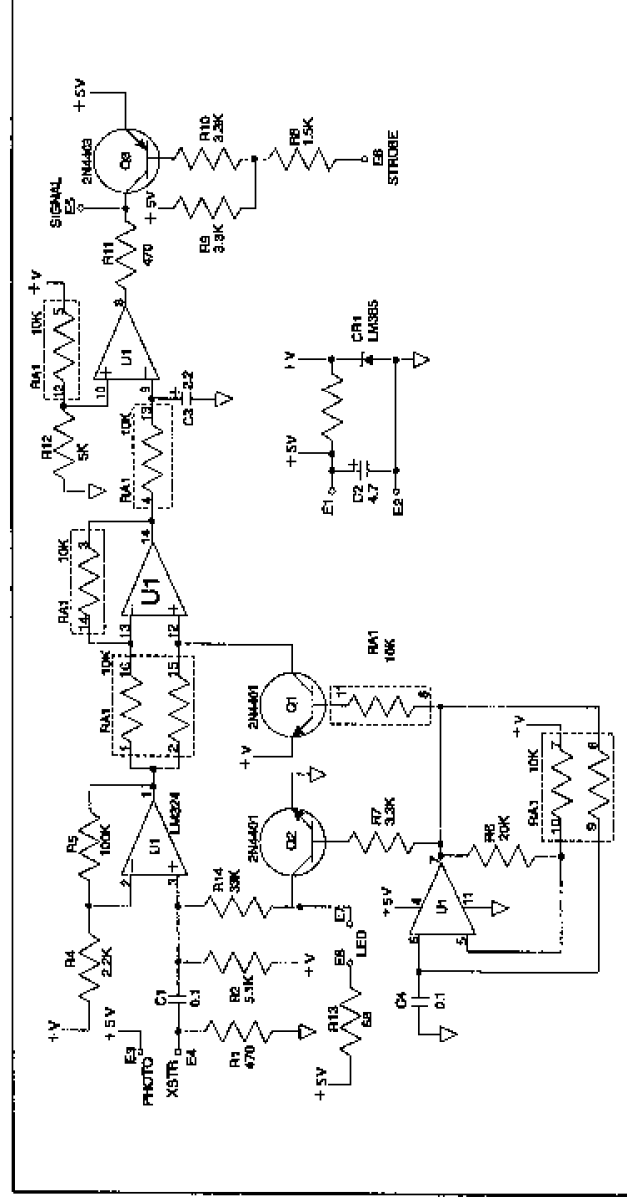

Figure 4-22. ECD Schematic (P/N 1301)

4.3.2.17a All except V8.xx. Empty Container Detector (Universal)

The Universal Empty Container Detector subsystem consists of an optical sensor with a signal amplifier and a signal conditioning circuit. The optical sensor and amplifier circuit are molded into the ECD assembly which attaches to the drip chamber of a primary administration set. The signal conditioning circuitry is incorporated internally on the ECD's printed circuit board. The microprocessor generates an ECD strobe to query the optical sensor. The strobe has the same duty

cycle as the strobe used with the AIL detector subsystem (see section 4.3.2.2). Without an ECD connected, the signal to the processor will always be read as a high. With an ECD connected and fluid in the drip chamber, the light beam is refracted, interrupting the optical path to the photo transistor and the ECD output signal is an inverted strobe signal which is read by the processor as a high. The detector's signal conditioning circuit (see figure 4-22a) uses a synchronous demodulator to minimize spurious signals resulting from ambient light reception. When the drip chamber empties,

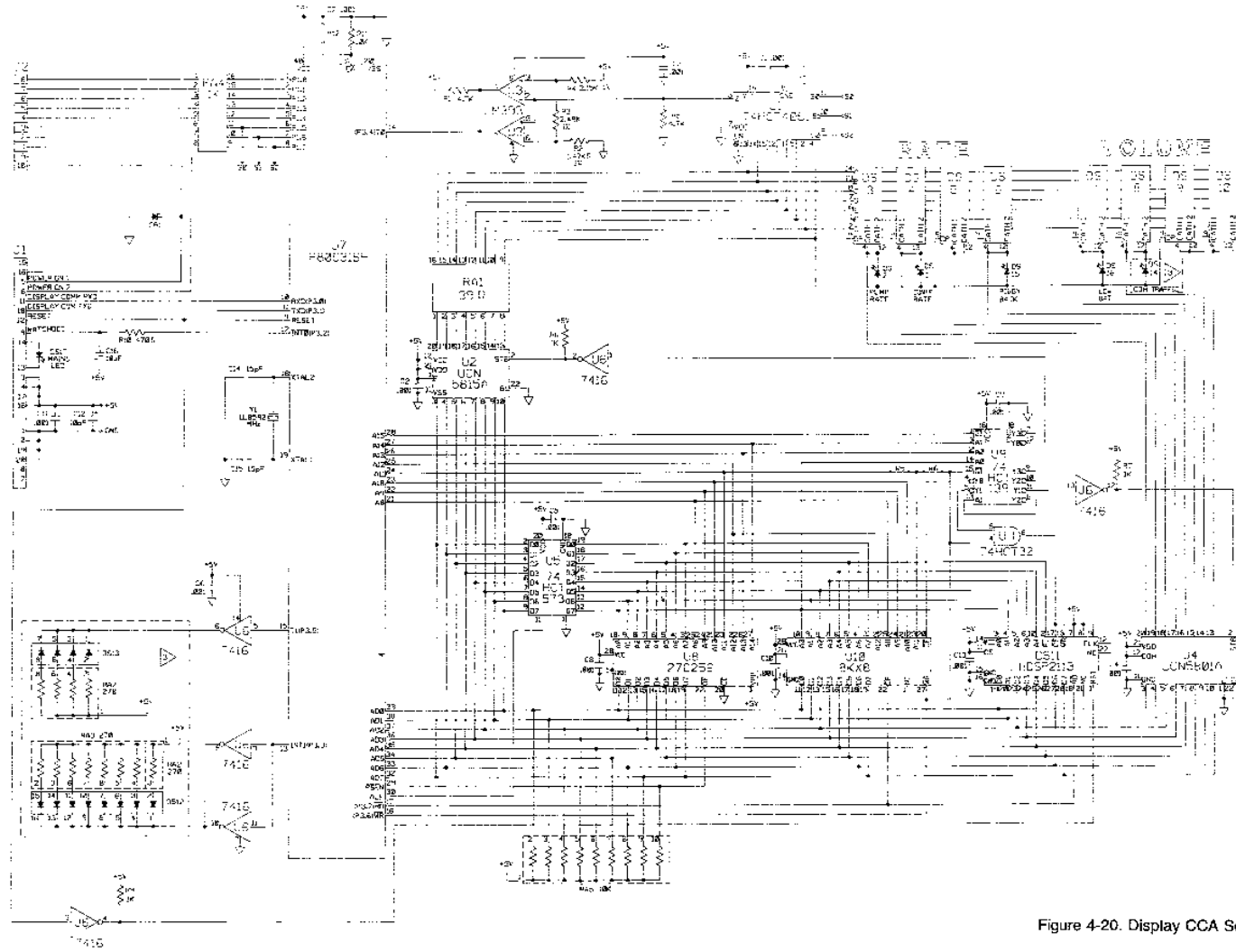

Figure 4-20. Display CCA Schematic [v2.xx/v5.xx]

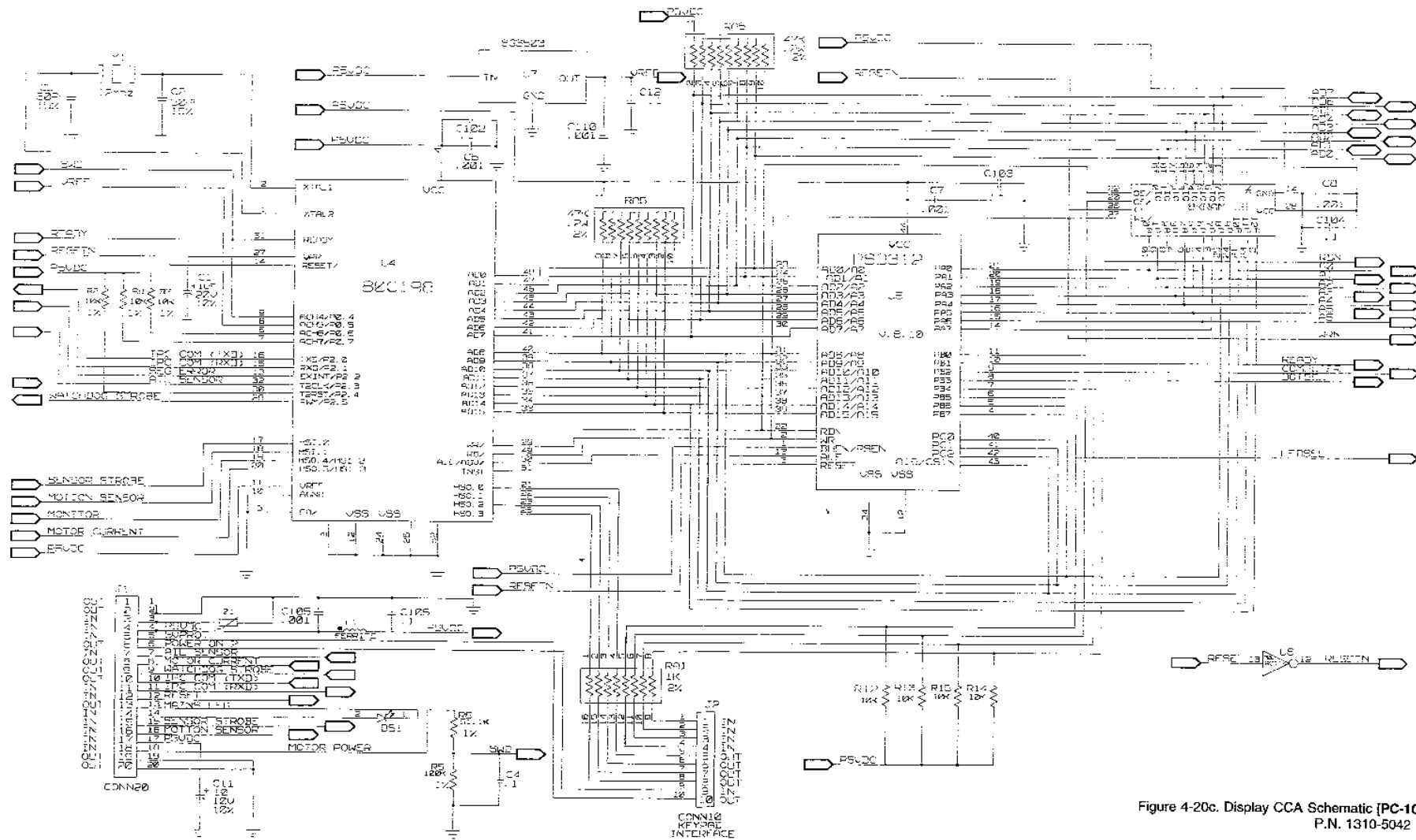

Figure 4-20c. Display CCA Schematic [PC-1CE v8.xx]
P.N. 1310-5042 (Sheet 1)

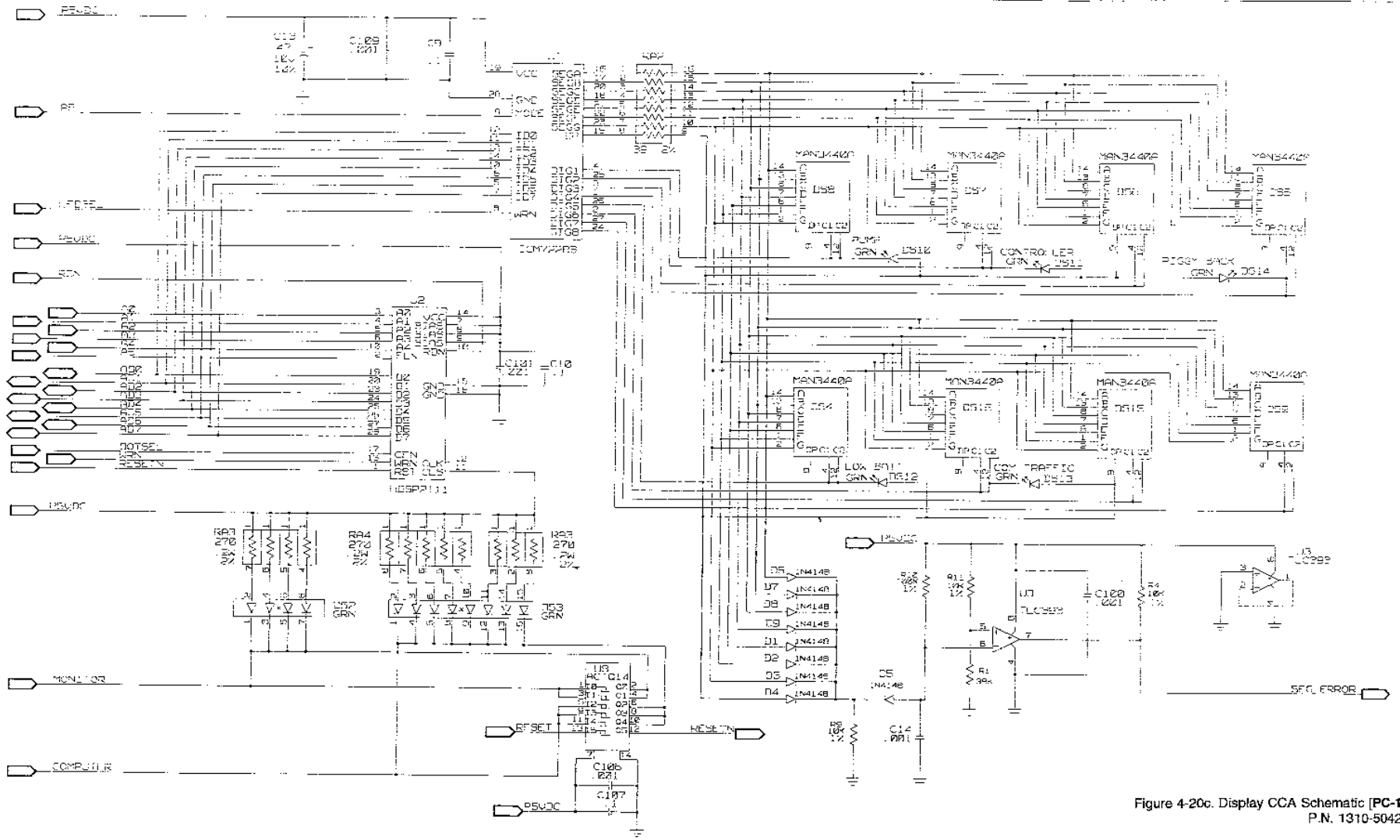

Figure 4-20c. Display CCA Schematic [PC-1CE v8.xx]
P.N. 1310-5042 (Sheet 2)

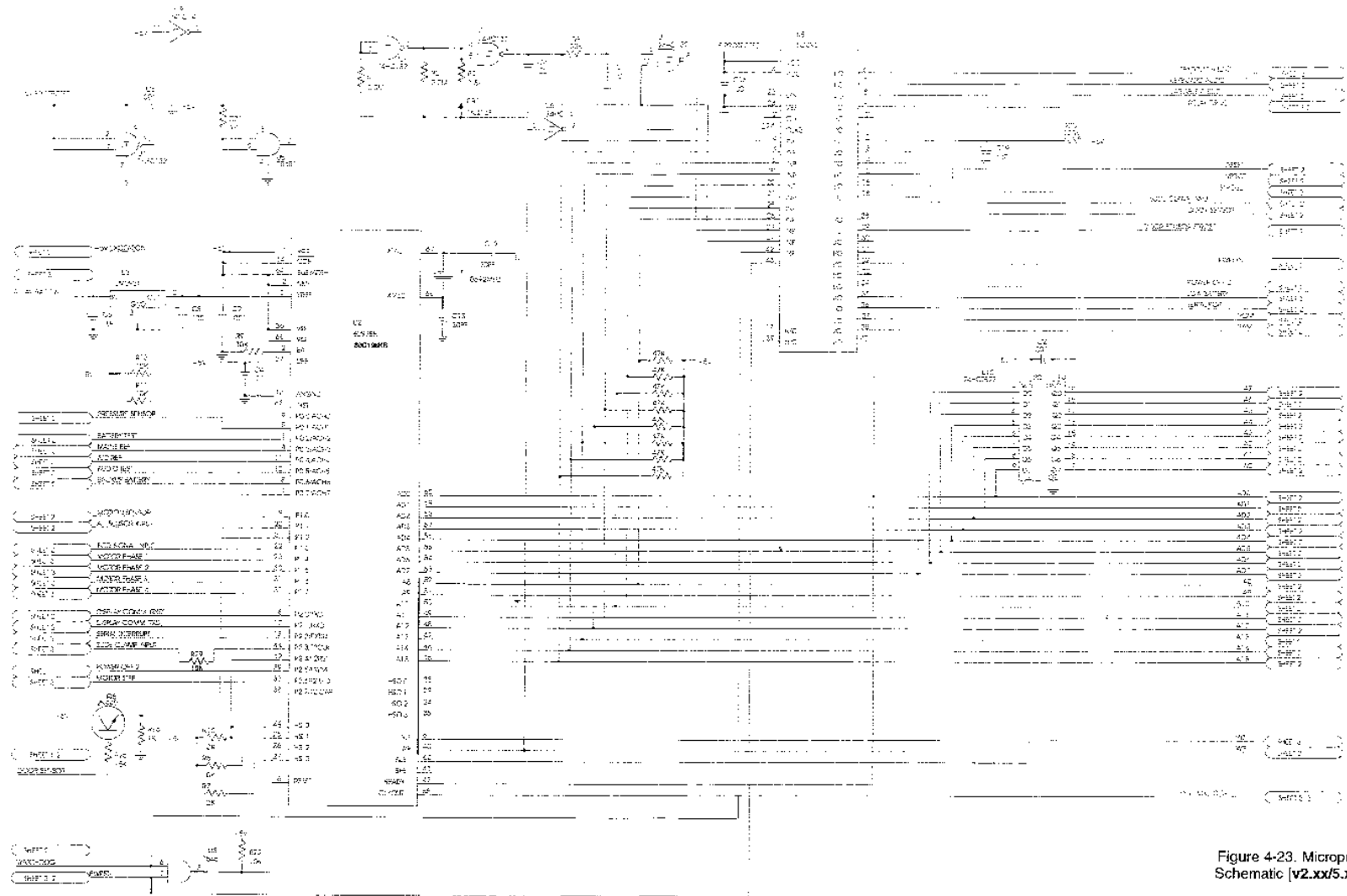

Figure 4-23. Microprocessor Interface Schematic [v2.xx/5.xx/6.xx] (Sheet 1)

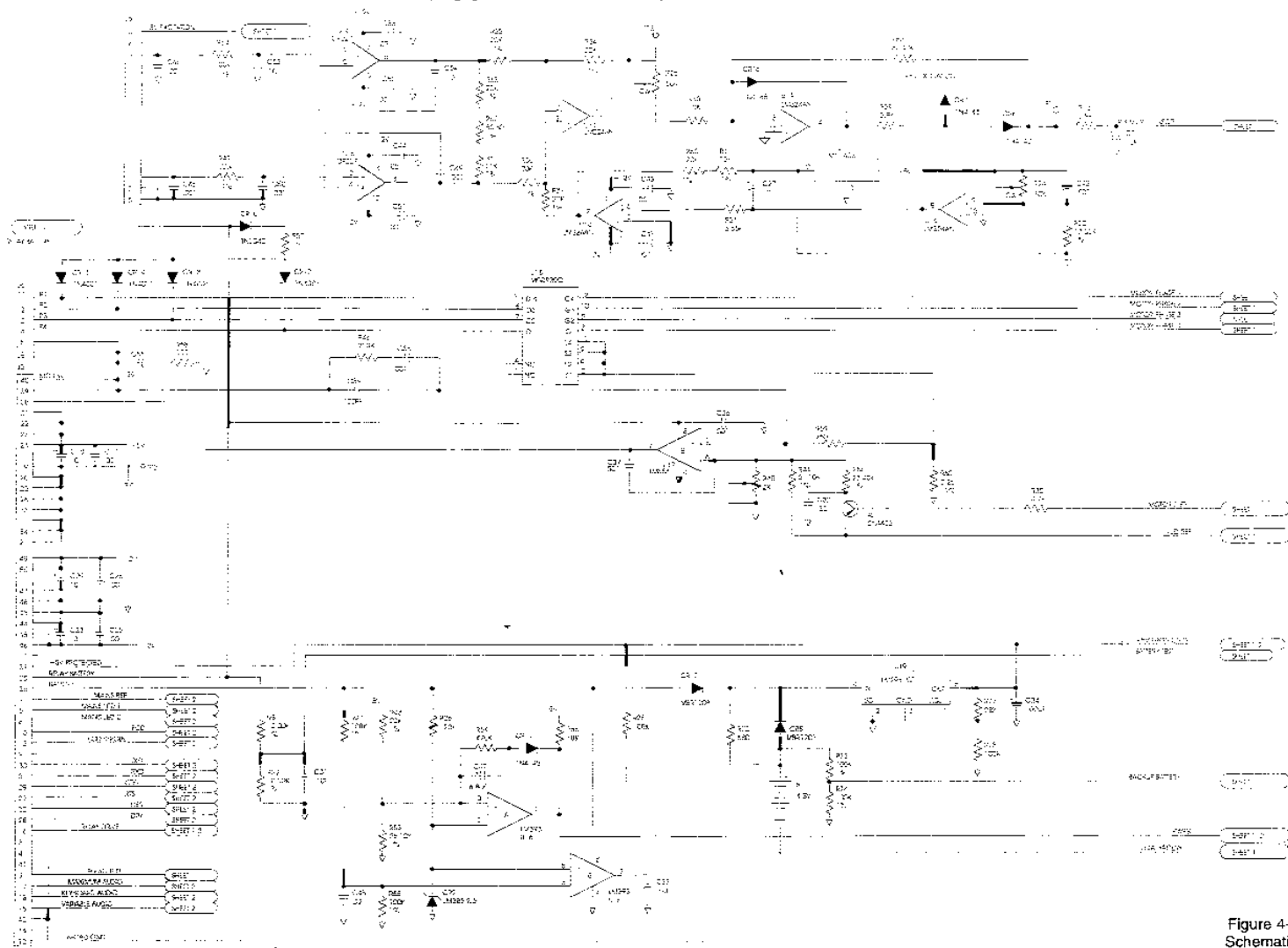

Figure 4-23. Microprocessor Interface Schematic [v2.xx/5.xx/6.xx] (Sheet 3)

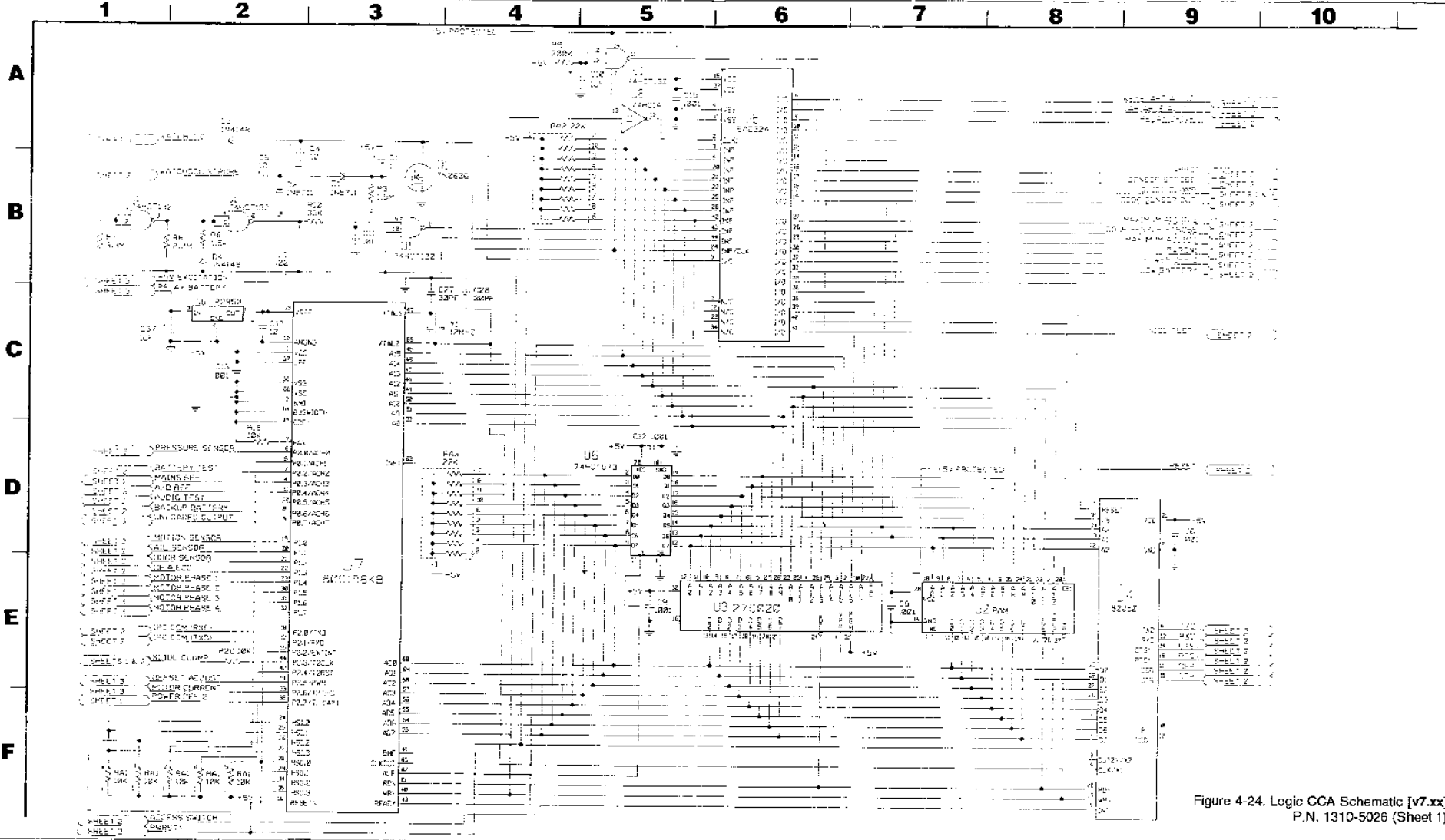

Figure 4-24. Logic CCA Schematic [v7.xx] P.N. 1310-5026 (Sheet 1)

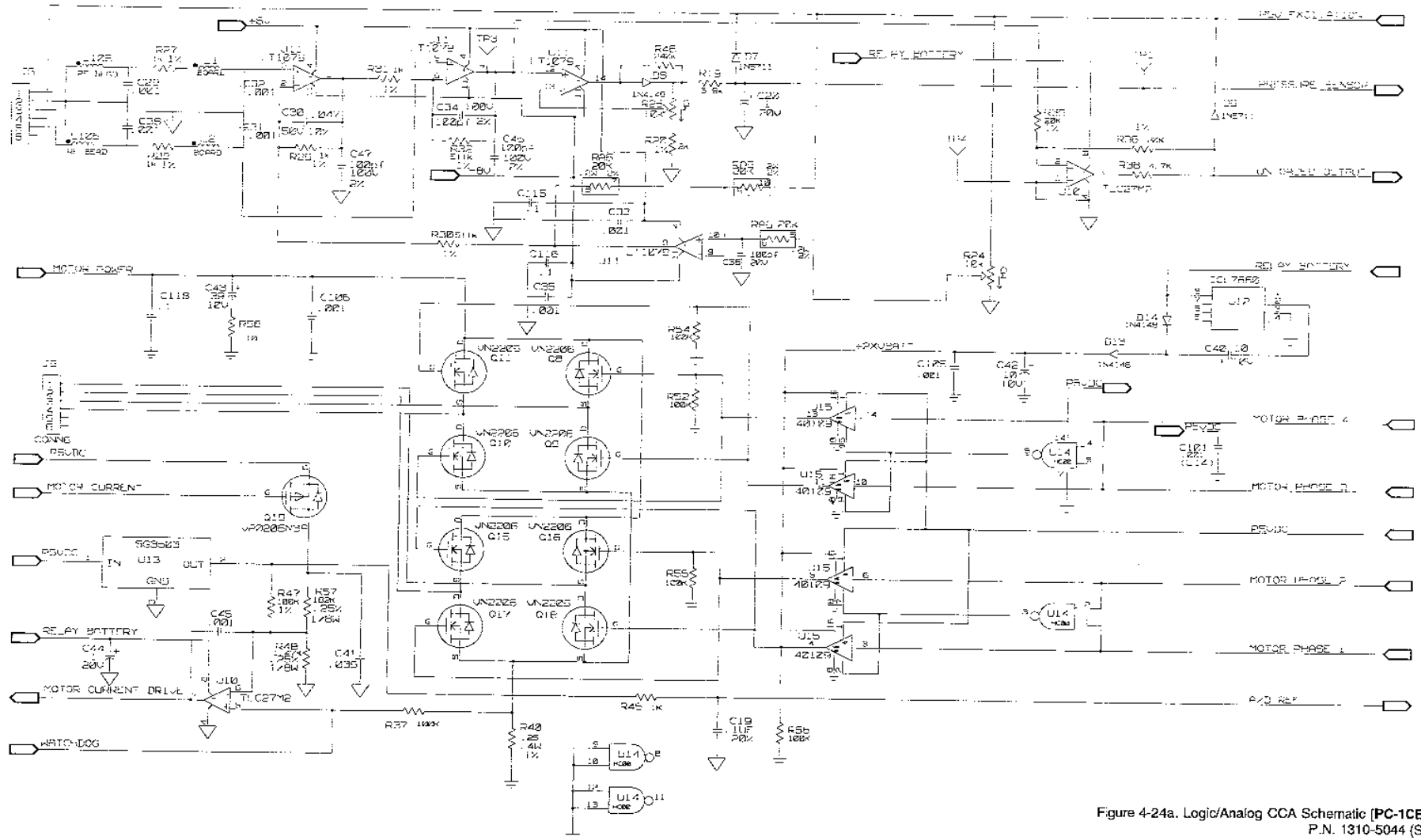

Figure 4-24a. Logic/Analog CCA Schematic [PC-1CE v8.xx]
P.N. 1310-5044 (Sheet 3)

SECTION 5 - MAINTENANCE

5.1 INTRODUCTION

This section contains preventive maintenance instructions, maintenance mode operating procedures, troubleshooting routines, disassembly and reassembly procedures and a comprehensive operational performance test for the IMED GEMINI PC-1 Volumetric Pump/Controller.

WARNING

Potentially lethal voltages are present within the PC-1 pump/controller case when the instrument is operated using external AC power. When the case is opened for maintenance action, it is recommended the instrument be operated using the internal battery.

CAUTION

Printed circuit boards (PCBs) are easily damaged when integrated circuits are removed and replaced. Excessive heat applied to the circuit board traces and pads can cause delamination of the metal foil and base material. Damage of that type is essentially irreparable; therefore, only low-temperature soldering irons and vacuum solder removal tools should be used when removing and replacing components on PCBs. Leads on integrated circuit components should be cut before attempting to un-solder and remove.

NOTE

CMOS devices are sensitive to static electrical charges and may be damaged during repair if the repair activity is not performed in an ESD protected environment using approved ESD protective procedures.

5.2 PREVENTIVE MAINTENANCE

The GEMINI PC-1 pump/controller is designed and assembled with the goal of minimizing maintenance requirements. The integral microprocessor incorporates a diagnostic routine that monitors the instrument's subsystems and operating parameters. Detection of operating system irregularities or failures that affect the instrument's functional operation activates audio and visual Alarms or Malfunction alerts for operator notification. Problems of this nature are recorded in the non-volatile RAM error log for subsequent use by biotechnical personnel in performing troubleshooting and repair actions.

Maintenance-free operation between regularly scheduled preventive maintenance inspections can be enhanced by performing routine cleaning on an 'as required' basis. The recommended interval for preventive maintenance inspections is once a year based on normal use and operation. Verification of proper instrument operation is the responsibility of the user. At the user's option, routine testing and verification may be performed at the factory for a nominal cost. The following paragraphs describe in detail the procedures for performing general maintenance requirements on the PC-1 pump/controller.

5.2.1 Cleaning Instructions

CAUTION

Always unplug the AC power cord before cleaning. Do not steam-sterilize/autoclave the instrument. Do not immerse the PC-1 pump/controller in any solution.

Exterior surfaces of the PC-1 pump/controller may be cleaned using any of the following recommended solutions. This list is considered adequate to permit clean up of all expected contaminants.

PC-1

Isopropyl alcohol
Warm soapy water
Household Bleach (10% solution, i.e. 1
part household bleach to 9 parts water)

These solutions may be applied using a soft, lint free cloth; a soft bristle brush and/or a cotton swab. Once the contamination has been removed, a cloth soaked with fresh water should be used to rinse the entire instrument removing and diluting all of the residual cleaning solution. Then the entire instrument surface should be completely rinsed using another cloth thoroughly moistened with fresh water. Following the fresh water rinses the instrument must be thoroughly dried with a soft, lint free cloth.

WARNING

Prior to reattaching the AC power cord to the instrument, ensure the mate base of the power input module is clean of any electrolyte and thoroughly dry. Check the female contacts on the power cord for contamination; if contaminated, replace the power cord.

5.2.2 Mechanical Inspection

Perform the following mechanical inspection:

- Inspect the urethane pumping seal for excessive wear and/or holes every 90 days or 1000 hours of instrument operating time. If damaged or worn, replace the seal.
- Perform a pumping mechanism extension spring integrity test by closing the IV set roller clamp while the pump is operating in the Pump mode. If only one spring is functioning, the channel will not occlude. Replace damaged or missing spring.
- Inspect the exterior case, front and rear, for holes, cracks, scratches, spalling, broken or damaged controls, missing components and/or screws.
- Inspect the amber and green tinted Lexan® windows covering the indicator displays for scratches or cracks.

- Ensure the pumping chamber access door fits flush with the case at the top, bottom, and sides.
- Check the door handle/cam lock for ease of operation and flush fit with door when latched.
- Inspect the air-in-line sensor and Flo-Stop recess for damage or obstructions.
- Install an approved IMED GEMINI administration set to ensure the Flo-Stop assembly seats correctly and the door closes and latches properly.
- Actuate each of the keypad controls on the front panel and the audio volume control potentiometer on the rear panel to ensure proper operation (see Figure 3-1 for location of controls).
- Inspect the power cord for damage, bent prongs or deformed connector.
- Exercise the pole clamp mechanism to ensure freedom of movement.

5.3 MAINTENANCE/DIAGNOSTICS MODE

The PC-1 pump/controller is configured with a Maintenance Mode that allows biotechnicians to access the software diagnostic subsystem. Once the Maintenance/Diagnostics Mode is enabled, the biotechnician can use the diagnostic test sequences to verify operation of the operator interface features, to operate the pumping mechanisms independent of the alarm/ malfunction interrupts, to check Analog to Digital voltages and to access the error log. Additionally, the Maintenance/Diagnostics mode is used to test the serial port, configure the instrument's communication interface and select one of the six available languages for the user interface presentations (PC-1 versions 2.xx/5.xx/6.xx only).

5.3.1 Maintenance/Diagnostics Mode Operation

WARNING

Prior to operating the PC-1 pump/controller in the Maintenance Mode ensure that the instrument is not connected to a patient.

Perform the following steps in the sequence presented to enable operation of the PC-1 pump/controller in the Maintenance Mode:

1. Unplug the AC power cord (it is recommended that maintenance operations be performed using battery power whenever possible). Press and hold the **COMPUTER CONTROL/MONITOR** switch while actuating the **POWER ON** control and check:
 - PC-1 Vx.xx scrolls once (x.xx = software version).
 - All LEDs and displays - illuminate for 7 seconds then extinguish.
 - "Maintenance Vx.xx" - scrolls continuously on the Operator Information display (x.xx = software version).
3. The PC-1 pump/controller is now initialized in the Maintenance Mode.

5.3.1.1 Maintenance/Diagnostics Mode Test Sequence

Series 2.xx/5.xx/6.xx Software

The Maintenance Mode test sequence appears in the following order after Maintenance Mode initialization:

- * LAMP TEST
- * KEYPAD TEST
- * ERROR LOG DISPLAY
- * MOTOR HOMING TEST
- * PUMP TEST
- * SERIAL PORT TESTS
- * A/D VOLTAGE DISPLAY
- * INPUT PORT DISPLAY
- * COMMUNICATIONS SETUP
- * LANGUAGE SELECTION
- * POWERDOWN TEST

(*) These features may not be in some software revisions.

Series 7.xx and 8.xx Software

The Diagnostics Mode test sequence appears in the following order after Diagnostics Mode initialization:

- * ERROR LOG DISPLAY
- * PUMP TEST
- * MOTOR HOMING TEST
- * A/D VOLTAGE TEST

- * INPUT PORT DISPLAY
- * LAMP TEST
- * KEYPAD TEST
- * COMMUNICATIONS SETUP
- * SERIAL PORT TESTS
- * ROM CRC DISPLAY
- * ROM CHECKSUM DISPLAY (7.xx ONLY)
- * BATTERY DATA DISPLAY
- * AUDIO TEST
- * POWERDOWN TEST

5.3.2 Maintenance Mode Test Suite

Performing the following procedures as written will provide access to each of the PC-1 pump/controller's maintenance mode diagnostic tests. Access to each of the maintenance mode test routines is achieved by pressing the **COMPUTER CONTROL/MONITOR** switch. Each test is identified by a scrolled confirmation message. While the test confirmation message is scrolling, actuation of the **START** key will initiate that specific test routine. The scrolled test confirmation message will be replaced by a statically displayed test phase identifier. The **COMPUTER CONTROL/MONITOR** switch may be used at any time to deselect the current test and proceed to the next test in the Maintenance Mode test sequence. Actuation of the **STOP** key while a test identifier is scrolling will interrupt the test sequence and powerdown the instrument [V2.xx/5.xx/6.xx]. Actuation of the **START** key while "Powerdown Test" scrolls on the Operator Information display will interrupt the test sequence and powerdown the instrument [V7.xx and 8.xx].

NOTE

When operating in the Maintenance Mode with the exception of Pump Test, the instrument will respond to and report a number of errors that are not checked during normal operation. Upon occurrence, the specific error message will be displayed statically on the Operator Information display in an "error nn" format with the "nn" representing a numerical code. Detailed Maintenance Mode error code information can be found in Table 5-2z.

LAMP TEST (with AUDIO)

1. Press **COMPUTER CONTROL/MONITOR**

PC-1

switch repeatedly until:

- "Lamp Test" - scrolls on Operator Information display.
2. Press **START** and check:
- Rate and VTBI displays - Flash sequentially numbers 0 0 0 through 9 9 9 followed by 0 0 0.0 through 9 9 9.9
 - Operator Information display - scrolls the alphabet in upper case and the numbers "0" - "9". **Software Release V5.xx** also displays the ".", "!" and "?" characters.
 - Controller and Pump delivery mode/operating. Secondary, Communication Traffic and Battery indicator LEDs illuminate steadily during one half of the test routine.
 - Audio tone - sounds once per second.

Fractional Keypad/Series V5.xx Software

- Audio tone may be cancelled by pressing any key.

KEYPAD TEST

1. Press **COMPUTER CONTROL/MONITOR** repeatedly until:
 - "Keypad Test" - scrolls on Operator Information display.
2. Press **START** and check:
 - "start" displays statically on Operator Information display.
3. Press each key (except **POWER ON** which provides no response and **COMPUTER CONTROL/MONITOR** which always terminates the active test) one at a time and verify the corresponding nomenclature for that key displays on the Operator Information display.

ERROR LOG DISPLAY

1. Press **COMPUTER CONTROL/MONITOR** repeatedly until:
 - "Error Log Display" - scrolls on Operator Information display.

2. Press **START** and check:
 - "empty" (no errors logged) appears on the Operator Information display. In this case proceed to the next maintenance mode test.
 - "newest" followed by "nm: cc" will display statically on Operator Information display (nm = number of entry from 01 to a maximum of 32, cc = error identification code - 000 to 255).
3. Press Units (1) digit key to read the error log:
 - Next oldest entry will display in "nm: cc" format or "no older" will appear.
4. Press **CLEAR** key and check:
 - Error log register clears - "wait" displays statically on the Operator Information display during a one second verification stage followed by either "okay" or "fail".

MOTOR HOMING TEST

NOTE: HOME STEP 150 POSITIONS THE MECHANISM FOR STRAIN BEAM CALIBRATION

1. Press **COMPUTER CONTROL/MONITOR** repeatedly until:
 - "Motor Homing Test" - scrolls on Operator Information display.
2. Press **START** and check:
 - VTBI displays either a "0" or the last selected homestep and "homestep" displays statically in the Operator Information display.
3. Use the Data Entry Controls to select a step (between 0 and 199) for homing. A selection >199 will revert display to "0".
4. Press **START** and check:
 - Pumping mechanism operates to seek the selected step, "----" appears in the VTBI display, "homing" displays statically in the Operator Information display and the Controller delivery mode/operating indicator

flashes.

- Pumping mechanism stops and the VTBI display shows the numerical value of the selected homing step.
- "homed" or "failed" displays statically in the Operator Information display.
- Pressing CLEAR or PAUSE/STOP loops the test back to step #2.

PUMP TEST

1. Press **COMPUTER CONTROL/MONITOR** repeatedly until:
 - "Pump Test" scrolls on the Operator Information display.
2. Press **START** and check:
 - "normal" displays statically on the Operator Information display.
3. Use the Units (1) digit Data Entry Control [V2.xx/5.xx/6.xx] or the RATE Titration arrow keys [V7.xx & subsequent] to select either the 'normal' or 'pressure' pump test mode. Each actuation will alternately step between normal and pressure. The mode selected will display statically on the Operator information display.

the Strain Beam is displayed in the VTBI display.

NOTES

Any time the pumping mechanism stops while in the pressure mode, the RATE and VTBI display revert to displaying the selected infusion Rate and decremented VTBI values.

Three motor revolutions following START, the pumping mechanism stops momentarily to check occlusion pressure and then resumes operation. This will result in a one time interruption of the pressure mode presentation with a flash display of the infusion parameters.

To change pump test mode selection, press **COMPUTER CONTROL/MONITOR back to step #3 providing a communication cable is NOT connected to the communications data port (RS-232-C).**

SERIAL PORT TESTS

Software Release V6.xx and previous

1. Press **COMPUTER CONTROL/MONITOR** and repeatedly until:
 - "Serial Port Tests" scrolls on the Operator Information display.
2. Install Communications Emulator plug in the RS-232-C connector on the rear panel. Test may also be performed using a remote terminal instead of a communications plug.
3. Press **START** and check:
 - "echo" displays statically on the Operator Information display.

Software Release V7.xx & subsequent

1. Press **COMPUTER CONTROL/MONITOR** and check:
 - "Serial Port Tests" scrolls on the Operator Information display.
- Install Communications Emulator plug in the RS-232-C connector on the rear panel. Test may also be performed using a remote

5. Use the procedures described in Section 3.3.1 to set up and operate the instrument.
6. When in the Pressure mode and after pressing **START** in step #5 above, check the following:
 - Calculated occlusion pressure voltage threshold for selected infusion parameters is displayed in the RATE display.
 - Voltage representing pressure sensed at

PC-1

terminal instead of a communications plug.

2. Press **START** and check:
 - "echo" displays statically on the Operator Information display.
3. Press **START** and check:
 - Each alpha, numeric and symbol in the communications character set is sent with a ? (e.g. A ?) in sequence.
 - "okay" appears in the Operator Information display if each byte sent is echoed within 3 seconds; otherwise "FAIL" appears in the VTBI display.
4. Press **CLEAR**. This will loop the test sequence back to step 3 above.
5. Press **PAUSE/STOP** and check:
 - "send" displays statically on the Operator Information display.
6. Press **START** and check:
 - Byte stream is sent out at the currently selected baud rate. Upon completion "okay" appears on the Operator Information display or "FAIL" appears in the VTBI display.
7. Press **CLEAR**. This will loop the test sequence back to step 6 above.
8. Press **PAUSE/STOP** and check:
 - "receive" displays statically on the Operator Information display.
 - Pressing **START** causes "input ?" to display.
9. (To conduct the "receive" test, the PC-1 pump/controller must be connected to a computer terminal using C2 Communication protocol P/N 1320-9004-01 or another PC-1 pump/controller).

A/D VOLTAGE DISPLAY

1. Press **COMPUTER CONTROL/MONITOR** repeatedly until:

- "A/D Voltage Test" scrolls on the Operator Information display.
2. Press **START** and check:
 - "strain" displays statically on the Operator Information display.
 - Strain beam voltage displays in the VTBI display.
 3. Press **RATE TITRATION** up arrow [V8.xx] and check: [if V2.xx/5.xx/6.xx/7.xx] skip this step and proceed to Step 4.)
 - "AIL gain" displays statically on the Operator Information display.
 - "0" displays in the VTBI display.
 4. Press **PAUSE/STOP** [V2.xx/5.xx/6.xx] or **RATE TITRATION** up arrow [V7.xx & subsequent] and check:
 - "sys batt" displays statically on the Operator Information display.
 - System battery voltage/2 displays on the VTBI display.
 5. Press **PAUSE/STOP** [V2.xx/5.xx/6.xx] or **RATE TITRATION** up arrow [V7.xx & subsequent] and check:
 - "V(mains)" displays statically on the Operator Information display.
 - A numerical value (≈245) appears on the VTBI display if AC power is present; otherwise approximately "0" will display.

NOTE

AC voltage measurement (V mains) is not a quantitative assessment, but rather a test for presence or absence of AC voltage.

6. Press **PAUSE/STOP** [V2.xx/5.xx/6.xx] or **RATE TITRATION** up arrow [V7.xx & subsequent] and check:
 - "V (ref)" displays statically on the Operator Information display.
 - A/D converter reference voltage (≈250

±5%) is displayed on the VTBI display.

7. Press PAUSE/STOP [V2.xx/5.xx/6.xx only] and check: (if V7.xx/V8.xx, skip this step and go to Step 8.)
 - "V(audio)" displays statically on the Operator Information display.
 - Normally a random number between "00" and "07" will display, as no audio is active.
8. Press PAUSE/STOP [V2.xx/5.xx/6.xx] or RATE TITRATION up arrow [V7.xx/V8.xx] and check:
 - "V(NVRAM)" [V2.xx/5.xx/6.xx] or "V(NICad)" [V7.xx/V8.xx] displays statically on the Operator information display.
 - NICAD battery voltage (≈285 for V7.xx & ≈274 for V8.xx) is displayed on the VTBI display. [V7.xx only & V8.xx] Press "1" key for loaded voltage display.

INPUT PORT DISPLAY

1. Press COMPUTER CONTROL/MONITOR repeatedly until:
 - "Input Port Display" scrolls on the Operator Information display.
2. Press START and check:
 - "selftest" [V2.xx/5.xx/6.xx] or "HW:HIGH" [V7.xx & subsequent] displays statically on the Operator information display.
 - Each digit in the RATE display and the units digit of the VTBI display will present either a "0" or "1" to indicate sensor output as described in the following table:

Rate - 1000 Digit = 1 = 0	ALL	Fluid in sensor Air in sensor
100 digit = 0 = 1	SCD	Sensor disabled for test MALFUNCTION
10 digit = 0 = 1	ECD	Air in sensor Fluid in sensor
1 digit = 0 = 1	MOTOR/ SYNC	Sensor sees Opaque Sensor sees Light
VTBI - 1 digit = 0 = 1	DOOR	Sensor Malfunction Sensor Operating

3. Press PAUSE/STOP and check:

- "normal" [V2.xx/5.xx/6.xx] or "HW:LOW" [V7.xx & subsequent] displays statically on the Operator information display.
- Each digit in the RATE display and the units digit of the VTBI display will present either a "0" or "1" to indicate sensor status as described in the following table:

Rate - 1000 Digit = 0 = 1	ALL	Sensor Operating Sensor Malfunction
100 Digit = 0 = 1	SCD	Slide Clamp In Slide Clamp Out
10 Digit = 0 = 1	ECD	Sensor Connected Sensor not Connected
1 Digit = 0 = 1	MOTOR/ SYNC	Sensor sees Opaque Sensor sees Light
VTBI - 1 Digit = 0 = 1	DOOR	Door Closed Door Open

COMMUNICATIONS SETUP

1. Press COMPUTER CONTROL/MONITOR repeatedly until:
 - "Communications Setup" scrolls on the Operator Information display.
2. Press START and check:
 - "serial #" displays statically on the Operator Information display.
 - "0" [V2.xx/7.00] [V5.xx/7.0000] [V7.xx and V8.xx] Software or the currently installed serial number will display on the VTBI display.
3. Use Data Entry Controls to change the serial number.
4. Press PAUSE/STOP and check:
 - "baudrate" displays statically on the Operator Information display.
 - Currently selected baud rate (110, 300, 600, 1200, 2400, 4800 or 9600) will display on the VTBI display.
5. Use Units (1) digit Data Entry Control [V2.xx/V5.xx/V6.xx] or RATE TITRATION

PC-1

up/down arrows [V7.xx & subsequent] to step through and select desired baud rate.

6. Press PAUSE/STOP and check:

- "parity" displays statically on the Operator Information display.
- Currently selected parity option 'O'(odd), 'E'(even) or 'OFF' displays on the VTBI display.

7. Use Units (1) digit Data Entry Control [V2.xx/V5.xx/V6.xx] or RATE TITRATION up/down arrows [V7.xx & subsequent] to step through and select desired parity option.

8. Press PAUSE/STOP and check:

- "stopbits" displays statically on the Operator Information display.
- Currently selected stop bits option ('1', '1.5' or '2' for V2.xx) or ('01', '1.5' or '02' V5.xx), or ('1' or '2' [V7.xx & subsequent]) displays on the VTBI display.

9. Use Units (1) digit Data Entry Control [V2.xx/V5.xx/V6.xx] or RATE TITRATION up/down arrows [V7.xx & subsequent] to step through and select desired stop bits option.

10. [V8.xx only] Press PAUSE/STOP and check

- "control?" displays statically on the Operator Information display.
- "yes" or "no" displays on the VTBI display.

11. [V8.xx only] Use RATE TITRATION up/down arrows to step through and select desired option.

LANGUAGE SELECTION [V2.xx/V5.xx/V6.xx only]

1. Press COMPUTER CONTROL/MONITOR repeatedly until:

- "Language Selection" scrolls on the Operator Information display.

2. Press START and check:

- "english" displays statically in the Operator Information display.

3. Use the Units (1) digit key to select one of the following languages: "german", "spanish", "swedish", "french" or "italian". Selection will appear on the Operator Information display.

Fractional Keypad/Series V5.xx and Subsequent The following functions if available are for IMED internal use only.

- RAM Display
- ROM CRC Display
- ROM CHECKSUM Display

BATTERY DATA DISPLAY Software Release V7.XX and subsequent

1. Press COMPUTER CONTROL/MONITOR repeatedly until:
 - "Battery Data Display" scrolls on the Operator Information display.
2. Press START and check:
 - "n" displays statically on the VTBI display and "lobatt 1" displays statically on the Operator Information display. When this appears, "n" in the VTBI display indicates the number of times the battery has dropped down to the "low battery 1" level, which is nominally 5.9 volts. (When a battery reaches "low battery 1" level, a "low battery" message scrolls across the Operator Information display.)

or

- "n" displays statically on the VTBI display and "lobatt 2" displays statically on the Operator Information display. When this appears, "n" in the VTBI display indicates the number of times the battery has dropped down to the "low battery 2" level, which is nominally 5.5 volts. (When a battery reaches "low battery 2" level, the pump goes into alarm status.)

or

- "n" displays statically on the VTBI display and "LB1 to 2" displays statically on the Operator Information display. When this appears, "n" in the VTBI display indicates the minimum number of seconds logged during any transition from "low battery 1" to

"low battery 2" since the last time this minimum was reset (the maximum displayable value is 9999). In the case where "low battery 2" has never been reached, "-----" appears in the VTBI display.

AUDIO TEST

1. Press **COMPUTER CONTROL/MONITOR** repeatedly until:
 - "Audio Test" scrolls on the Operator information display.
2. Press **START** and check:
 - "no audio", "key", "variable", and "max" appear in the Operator information display.
 - associated feedback voltages appear in the VTBI display.
 - an audible tone is sounded that increases in intensity as each message appears in the Operator information display.

POWERDOWN TEST

1. Press **COMPUTER CONTROL/ MONITOR** repeatedly until:
 - "Powerdown Test" scrolls on the Operator Information display.
2. Press **START** and check:
 - "OFF n" displays statically on the Operator Information display ('n' counts down in seconds from 3 to 1)
 - After reaching 1 the instrument shuts down.

MECHANISM ALARM CIRCUIT (M.A.C.)

Gemini PC-1 instruments are being manufactured with a pump mechanism alarm circuit (M.A.C.) to enhance detection of impact damage to the instrument as the result of dropping or other abnormal handling.

If a PC-1 pump/controller goes into an alarm condition and scrolls "HELP INTERNAL ERROR" following Power On, check the Error Code on the Central Display. These alarm conditions are

associated with either faulty ALL hardware or a disconnect in the pump mechanism alarm circuit. To determine the specific problem, perform the following troubleshooting procedures.

- a. Turn off the instrument and remove the AC power cord from the AC outlet.
- b. Separate the case (refer to Section 5.5.1).
 - Use a 5/32" Allen driver or wrench to remove the four socket head screws that connect the front and rear case assemblies. (Do not leave screws on work surface. Front panel could be damaged if front case is laid on the screws).

NOTE

When separating and positioning the front and rear cases for M.A.C. installation, ensure that no tension is applied to the harnesses connecting the case assemblies.

- c. Inspect the upper and lower M.A.C. assembly contacts on each pump mechanism for a disconnected condition.
- d. If the M.A.C. contacts (spring clips) are in place, inspect the M.A.C. wires and connectors for a cut or break.
- e. If the M.A.C. circuit is intact, then the alarm condition can be attributed to an ALL hardware problem. Follow maintenance manual procedures for troubleshooting, removal and replacement of the ALL/SCD assembly.
- f. If the M.A.C. contacts are disconnected, the instrument has been subjected to an abnormal impact condition. Visually inspect the pump mechanism(s) for severe cracks or breaks in the areas around the mounting flanges and housing pivot points. Small cracks do not affect functionality.
- g. If no visual damage is detected, attempt to move the top of the pump mechanism laterally (side to side). If the mechanism is intact, there will be very little, if any, lateral motion. If the mechanism is broken, the lateral movement will be easily discernible.

NOTE

Do not mistake movement of the top of the pump mechanism along the hinge axis as

PC-1

lateral movement.

- h. If the mechanism is intact, with no severe cracks or breaks, inspect the M.A.C. components for obvious damage; e.g., severely bent copper components. If all components are intact and undamaged, reconnect the upper and lower M.A.C. spring clips.

NOTE

It is important that the M.A.C. spring clips be compressed only the amount necessary to allow the contacts to be inserted into the slots on the top plate.

- i. If a mechanism is severely cracked or broken, or if the M.A.C. system is damaged, replace the damaged components.

5.4 TROUBLESHOOTING

The troubleshooting routines presented in the Table 5-1 are correlated directly to the Maintenance Mode test sequence described in Section 5.3. The recommended troubleshooting

procedure is to perform the Maintenance Mode test that replicates the reported discrepancy; e.g., if a control key is not functioning - run the Keypad test, if a LED segment is out - run the Lamp test, if the instrument fails to power-up - check the probable causes under Initialization.

The corrective actions are listed in a descending order of failure probability. Performing the corrective actions in the sequence provided should reduce repair time and expedite returning the instrument to patient care service. If the test equipment required to troubleshoot and repair a microprocessor system is not available at your facility, it is recommended the instrument be returned to the factory for repair.

Table 5-1. Troubleshooting/Fault Isolation Guide

Test/Fault	Probable Cause	Corrective Action
INITIALIZATION		
LEDs fail to illuminate	Battery <5.3 Volts Blown Fuse (Input Module) F1 on Power Supply PCB blown POWER ON switch inoperative	Connect AC Power Replace fuse Replace fuse Check Keypad Cable Connector Test/Replace Keypad
No Alarm tone	NICAD Battery Failure	Replace NICAD Battery
LEDs stay ON	Digital Logic Failure	Replace Digital Logic Board
VERSION DISPLAY	Audio Oscillator Failure	Replace Audio Oscillator
'maintenance Vx.xx vice 'PC-1 Vx.xx'	Digital Logic Failure	Replace Digital Logic Board
'PC-1 Vx.xx' vice 'maintenance Vx.xx'	Initialized in Maintenance Mode COMPUTER CONTROL/ MONITOR switch not held during initialization	Reinitialize in Normal Mode Reinitialize - hold COMPUTER CONTROL/MONITOR switch during initialization

Model/Version fails to scroll	COMPUTER CONTROL/ MONITOR switch failure	Replace Keypad
Model/Version display corrupted	Digital Logic Failure Display Board Failure Power Supply Board Failure	Replace Digital Logic Board Replace Display Board Replace Power Supply Board
LAMP TEST w/AUDIO	Digital Logic Failure Display Board Failure	Replace Digital Logic Board Replace Display Board
LED segment fails to illuminate	Display Board Failure Digital Logic Failure	Replace Display Board Replace Digital Logic Board
No Audio adjust	Audio Control Pot. Failure	Replace Audio Control Pot.
KEYPAD TEST	Keypad Failure Display Board Failure	Replace Keypad Assembly Replace Display Board
ERROR LOG DISPLAY (See Table 5-2, 2a or 2b for a listing and description of Error Log Codes)		
MOTOR HOMING TEST		
Motor Fails to Home to selected position ± 1 step	Motor Harness Disconnected	Reconnect Motor Harness
	Digital Logic Failure	Replace Digital Logic Board
	Motion Sensor Harness Disconnected	Reconnect Motion Sensor Harness
	Motion Sensor Failure	Replace Motion Sensor
PUMP TEST (Allows pumping mechanism to be operated without Alarm stoppage)		
SERIAL PORT TEST		
"echo" test fail	Faulty Communication Plug Digital Logic Board Failure Power Supply Board Failure	Replace Comm Emulator Plug Replace Digital Logic Board Replace Power Supply Board
AVD VOLTAGE DISPLAY		
"strain" reading > '0', set not installed	Strain Beam Out of Calibration Strain Beam Failure Digital Logic Board Failure	Recalibrate Strain Beam (see Section 5.7) Replace Strain Beam Replace Digital Logic Board

PC-1

"strain" reading <'100' or >'200' with dry pumping segment installed	Strain Beam Out of Calibration	Recalibrate Strain Beam
"sys batt" reading <'279' or >'355'	Strain Beam Failure Digital Logic Board Failure Power Supply Board Failure	Replace Strain Beam Replace Digital Logic Board Check Battery Voltage at in-line fuse
"V(mains) reading <'245' or >'255' (AC connected)	Digital Logic Board Failure Battery Failure Wrong Battery Installed	Replace Power Supply Board Replace Digital Logic Board Replace Battery
"V(ref)" other than '249'±05%	Power Supply Board Failure	Install IPB Listed Battery
"V(audio)" normally 0	Power Supply Board Failure	Replace Power Supply Board
"V(NVRAM)" reading <'246' or >'328'	Digital Logic Board Failure	Replace Digital Logic Board
N/A	NiCad Battery Failure	Recharge NiCad Battery
"V(NVRAM)" reading <'246' or >'328'	Digital Logic Board Failure	Replace NiCad Battery
Power Supply Board Failure	Power Supply Board Failure	Replace Digital Logic Board
INPUT PORT TEST	Power Supply Board Failure	Replace Power Supply Board
	'Normal' mode	See Section 5.3.2 Maintenance Mode Operation - Input Port Test for expected readout in Normal and Selftest modes.
AIL Sensor - wrong digit for condition	NOTE	The logic for the AIL and ECD sensors is reversed in relation to the other sensors (ECD sensors applicable to 110V only, except V8.12). Consequently, in the Normal mode test the AIL and ECD sensors are being tested for response to the processor strobe rather than sensor operation. The following AIL and ECD sensor operation tests indicate the response expected when conducting a test in the 'Selftest' mode.
		Ultrasonic Emitter/Receiver failure
	Analog Circuit Failure	Replace AIL/SCD PC Board

PC-1

<p>1003 only (except V8.12). ECD Sensor - wrong digit for condition</p> <p>SCD Sensor - wrong digit for condition</p> <p>Motion Sensor - wrong digit for condition</p> <p>Door Sensor - wrong Digit for condition</p>	<p>Digital Logic Board Failure</p> <p>Light Emitter/Receiver Failure</p> <p>Communication Cable Failure</p> <p>Power Supply Board Failure</p> <p>Digital Logic Board Failure</p> <p>Light Emitter/Receiver Failure</p> <p>Digital Logic Failure</p> <p>Sensor Failure</p> <p>Digital Logic Board Failure</p> <p>Sensor Failure</p> <p>Digital Logic Board Failure</p>	<p>Replace Digital Logic Board</p> <p>Replace ECD</p> <p>Reconnect or Replace Communication Cable</p> <p>Replace Power Supply Board</p> <p>Replace Digital Logic Board</p> <p>Replace AIL/SCD Assembly</p> <p>Analog Circuit Failure Replace AIL/SCD PC Board</p> <p>Replace Digital Logic Board</p> <p>Replace Sensor</p> <p>Replace Digital Logic Board</p> <p>Replace Sensor</p> <p>Replace Digital Logic Board</p>
<p>RAM Display.</p>	<p>For IMED Engineering use only</p>	
<p>POWER DOWN TEST</p>		
<p>Displays remain On</p>	<p>Digital Logic Board Failure</p>	<p>Replace Digital Logic Board</p>

NOTE

In the 'Selftest' mode, the microprocessor is strobing the sensors in accordance with a software protocol. The digital presentation seen in the RATE and VTBI displays reflects the sensor response to the strobe. If the response is not the expected response, a problem exists within the strobe circuitry.

Table 5-2. PC-1 Error Log Codes (V2.xx, V5.xx, V6.XX and V6.3x/4x)

The Error Codes listed below represent the results of software initiated subsystem tests. The tests are evaluated on Pass/Fail logic with an error code generated for a fail condition.

Code No.	Description	Meaning	Probable Cause
00	NOT USED		
01	Error Log	Occurs only during startup; the Error Log is reset resulting in loss of resident error log entries.	Logic Board Battery Circuit Check voltage at RAM VCC: If: <2.0V - NICAD battery failure
02	ROM	Detected during power-up; instrument fails CRC check and powers down immediately WITHOUT alarm.	Logic Board
03	NVRAM	Detected during power-up. The portion of RAM subjected to a CRC test fails. Failure results in loss of previously selected infusion parameters. Default parameters display.	Battery excessively discharged. Attempt recharge for 4 hours Logic Board Battery Circuit (see Error Code #1)
	<i>Software Release V6.3x/4x</i>	<i>Not Implemented</i>	
04	RAM	During power-up a destructive RAM test is performed on RAM segments not related to infusion parameters. Instrument fails this validity check and powers down WITHOUT alarm.	Logic Board
05	Critical parameters out of range	During power-up a range check is performed on infusion parameters stored in NVRAM. Failure of this check results in loss of previously selected infusion parameters. Default parameters are displayed.	Logic Board Battery Circuit (see Error Code #1)
	<u>Software Release V6.xx</u>	If a variable is out of range the following occurs: a transparent 9x error code is logged, "HELP INTERNAL ERROR" scrolls, an audio alarm sounds, NVRAM values revert to default, all keys except PAUSE/STOP are disabled.	
	<u>Software Release V6.3x/4x</u>	<i>Not Implemented</i>	

06	Battery	During power-up voltage is checked; measurements >8.0 or ≤ 5.7 VDC cause the instrument to immediately power down WITHOUT Alarm.	Battery excessively discharged. Attempt recharge for 4 hours Battery Circuit (see Error Code #1) Logic Board
07	A/D	Occurs during power-up battery check or any subsequent A/D conversion. An A to D Interrupt is programmed upon completion of A/D readings. Failure to detect this Interrupt within a pre-determined time frame will cause the instrument to lock up and display the error code in the VTBI display.	Logic Board
08	Invalid Key	Occurs when a keycode is received that is outside of the legal keycode range. An error is logged, "HELP INTERNAL ERROR" scrolls, audio alarm sounds, pumping stops, all keys except PAUSE/STOP are disabled and error code is displayed in VTBI.	Display Board Logic Board
09-11	NOT USED		
12	<u>Software Release V2.xx</u> General Software Error <u>Software Release V5.xx</u> NOT USED <u>Software Release V6.xx</u> and <u>V6.3x/4x</u> General Software Error	Occurs when a runaway program is detected during a routine check of software logic. "HELP INTERNAL ERROR" scrolls, the Error Code is displayed in the VTBI, audio alarm sounds and all keys except PAUSE/STOP are disabled.	Logic Board
13	Motor Sync Off	Occurs when an error $>1.5\%$ in a sample of 50 motor revolutions is detected by the motion sensor. "HELP INTERNAL ERROR" scrolls, audio alarm sounds, error code is displayed in VTBI and all keys except PAUSE/STOP are disabled.	Pumping Mechanism
14	NOT USED		

38	Low Battery II Error	Occurs when an A/D converter reads a battery voltage below $\approx 5.4V$. "HELP BATTERY" scrolls, audio alarm sounds, pumping stops, error code displays on VTBI and all keys except PAUSE/STOP are disabled.	Battery excessively discharged. Attempt recharge for 4 hours Lead Acid Battery Power Supply Board
39	NOT USED		
40	<u>Software Release V6.3x/4x</u> Error Log NVRAM Variables	<i>Error Log partition of partitioned NVRAM experienced a CRC failure between power-down and power-up. Variables in effected partition are initialized to default values and error code is logged. Instrument is usable.</i>	<i>Improper Power-down</i> NVRAM Battery Logic Board
41	<u>Software Release V6.3x/4x</u> Fixed Biotech Setup NVRAM Variables	<i>Fixed Biotech Setup partition of partitioned NVRAM experienced a CRC failure between power-down and power-up. Variables in effected partition are initialized to default values and error code is logged. Instrument is usable.</i>	<i>Improper Power-down</i> NVRAM Battery Logic Board
42	<u>Software Release V6.3x/4x</u> Non-Critical State NVRAM Variables	<i>Non-Critical State partition of partitioned NVRAM experienced a CRC failure between power-down and power-up. Variables in effected partition are initialized to default values and error code is logged. Instrument is usable.</i>	<i>Improper Power-down</i> NVRAM Battery Logic Board
43	<u>Software Release V6.3x/4x</u> Non-Critical Data NVRAM Variables	<i>Non-Critical Data partition of partitioned NVRAM experienced a CRC failure between power-down and power-up. Variables in effected partition are initialized to default values and error code is logged. Instrument is usable.</i>	<i>Improper Power-down</i> NVRAM Battery Logic Board
44	<u>Software Release V6.3x/4x</u> TPN Data NVRAM Variables	<i>TPN Data partition of partitioned NVRAM experienced a CRC failure between power-down and power-up. Variables in effected partition are initialized to default values and error code is logged. Instrument is usable.</i>	<i>Improper Power-down</i> NVRAM Battery Logic Board
45	<u>Software Release V6.3x/4x</u> Critical State NVRAM Variables	<i>Critical State partition of partitioned NVRAM experienced a Validity check failure between power-down and power-up. Effected variables in effected partition are initialized to default values and error code is logged. Instrument is usable.</i>	<i>Improper Power-down</i> NVRAM Battery Logic Board

46	<u>Software Release V6.3x/4x</u> <u>Critical Data NVRAM</u> <u>Variables</u>	<i>Critical Data partition of partitioned NVRAM experienced a Validity check failure between power-down and power-up. Effected variables in effected partition are initialized to default values and error code is logged. Instrument is usable.</i>	<i>Improper Power-down</i> <i>NVRAM Battery</i> <i>Logic Board</i>
47-58	NOT USED		
59	<u>Software Release V6.xx</u> <u>and V6.3x/4x</u> <u>IPC Synchronization</u>	Unacceptable level of Inter-processor communication failures. "HELP INTERNAL ERROR" scrolls, audio alarm sounds, error code displays on VTBI, pumping stops and all keys except PAUSE/STOP are disabled.	Logic Board Display Board
60	NOT USED		
61	<u>Software Releases</u> <u>V2.xx/V5.xx</u> Three bad messages (IPC) <u>Software Release V6.xx</u> <u>and V6.3x/4x</u> NOT USED	This error code is related only to software diagnostics.	Not hardware related, no action required
62	<u>Software Release V6.xx</u> <u>and V6.3x/4x</u> <u>Power-up Audio</u>	During power-up A/D converter checks audio transducer input voltage to be >0.2VDC during audio activity. If not "HELP INTERNAL ERROR" scrolls, audio alarm sounds, error code displays on VTBI, pumping stops and all keys except PAUSE/STOP are disabled.	Logic Board
63	NOT USED		
64	NVRAM Battery	NVRAM battery voltage is <2.4 VDC for a specified period, then: "HELP BATTERY" scrolls, audio alarm sounds, error code displays on VTBI, pumping stops and all keys except PAUSE/STOP are disabled.	Logic Board
65	<u>Software Release V6.xx</u> <u>and V6.3x/4x</u> <u>EPROM/Software Version</u> <u>Mismatch</u>	At power-up logic board processor checks version number of display processor software. If a mismatch: "HELP INTERNAL ERROR" scrolls, audio alarm sounds, error code displays on VTBI, pumping stops and all keys except PAUSE/STOP are disabled.	Wrong Display EPROM Wrong Logic EPROM

Table 5-2a. PC-1 Error Log Codes (V7.xx)

The Error Codes listed below represent the results of software initiated subsystem tests. The tests are evaluated on Pass/Fail logic with an error code generated for a fail condition.

Code No.	Description	Meaning	Probable Cause
00	NOT USED		
01	Error Log	Occurs only during startup; the Error Log is reset resulting in loss of resident error log entries.	Logic Board Battery Circuit Check voltage at RAM VCC after charging battery for ≥8 hours: If: <2.0V - NICAD battery failure
02	RESERVED FOR PC-1 6.XX		
03	RESERVED FOR PC-1 INTEGER		
04	RAM	During power-up a destructive RAM test is performed on RAM segments not related to infusion parameters. Instrument fails this validity check and powers down WITHOUT alarm.	Logic Board
05	RESERVED FOR PC-1 INTEGER		
06	Battery	During power-up voltage is checked; measurements >8.0 or <5.15 VDC cause the instrument to immediately power down WITHOUT alarm.	Battery excessively discharged. Attempt recharge for 4 hours. Battery Circuit (see Error Code #1)
07	A/D	Occurs during power-up battery check or any subsequent A/D conversion. An A to D Interrupt is programmed upon completion of A/D readings. Failure to detect this Interrupt within a pre-determined time frame will cause the instrument to lock up and display the error code in the VTBI display.	Logic Board

08	Invalid Key	Occurs when a keycode is received that is outside of the legal keycode range. An error is logged, "HELP INTERNAL ERROR" scrolls, audio alarm sounds, pumping stops, all keys except PAUSE/STOP are disabled and error code is displayed in VTBI.	Display Board Logic Board
09-12	ROM Bank [0, 1, 2, 3] - Checksum	During power-up, a checksum value is calculated for the four ROM banks. If the value does not match a precalculated "correct" value, a corruption of ROM is suspected, and the instrument is shut down WITHOUT alarm.	Logic Board
13	Motor Sync Off	Occurs when an error >1.5% in a sample of 50 motor revolutions is detected by the motion sensor. "HELP INTERNAL ERROR" scrolls, audio alarm sounds, error code is displayed in VTBI and all keys except PAUSE/STOP are disabled.	Pumping Mechanism Logic Board Power Supply Board
14	RESERVED FOR PC-2 TITRATION		
15	No Sync Flag detected	Occurs 120 motor steps after the motion sensor fails to confirm motor sync. The motion sensor is inoperative or the motor is not turning. "HELP INTERNAL ERROR" scrolls, audio alarm sounds, error code displays in VTBI, pumping stops and all keys except PAUSE/STOP are disabled.	Logic Board Power Supply Board Pumping Mechanism
16	RESERVED FOR PC-2 TITRATION		
17	RESERVED FOR PC-2 INTEGER		
18	Fast Battery Discharge	After ≥1 hour of continuous operation on AC power, instrument must operate for >1/2 the charged time on battery; if unable, a fast battery discharge condition occurs: "HELP BATTERY" scrolls, audio alarm sounds, error codes 18 and 38 are logged, error code 38 displays in VTBI, pumping stops and all keys except PAUSE/STOP are disabled.	Battery Capacity Diminished Battery Charger Circuitry Power Supply Board

19	Improper Power-Down	Occurs when the instrument is powered-down without using the PAUSE/STOP control (i.e. Watchdog or battery failure). During the next power-up, the instrument will enter an Internal Error condition: "HELP INTERNAL ERROR" scrolls, audio alarm sounds, error code is logged and displayed in VTBI and all keys except PAUSE/STOP are disabled.	Normal power-down sequence must be activated to reset instrument. Logic Board Power Supply Board Battery
20	Door Alarm	Occurs when the microprocessor detects a failure of the door sensor. "HELP INTERNAL ERROR" scrolls, audio alarm sounds, error code displays in VTBI, pumping stops and all keys except PAUSE/STOP are disabled.	Logic Board Door Harness Assembly
21	RESERVED FOR PC-2 TITRATION		
22	AIL Alarm	Occurs when the microprocessor detects a failure of the AIL sensor. "HELP INTERNAL ERROR" scrolls, audio alarm sounds, error code displays in VTBI, pumping stops and all keys except PAUSE/STOP are disabled.	AIL Board AIL/Door Harness Logic Board
23	RESERVED FOR PC-2 TITRATION		
24-25	Inverse Flag Errors	During power-up or runtime, important variables are checked against their inverse copies to verify that no RAM bit corruption has taken place. If any of the inverse flags are incorrect, "HELP INTERNAL ERROR" scrolls, "24" or "25" is displayed in VTBI, "0" in RATE, audio alarm sounds, and all keys except PAUSE/STOP are disabled.	Logic Board
26	Battery Overcharge	Occurs when battery voltage >8.0 VDC is detected during normal instrument operation. "HELP INTERNAL ERROR" scrolls, audio alarm sounds, error code displays in VTBI, pumping stops and all keys except PAUSE/STOP are disabled.	Power Supply Board
27	RESERVED FOR PC-2 TITRATION		

28	Illegal ROM Access Failure	All unused ROM is protected from execution through illegal ROM space. If there is an illegal ROM access failure, the instrument logs the error code and enters a watchdog condition.	Logic Board
29	Short LB1 to LB2 Time	After a minimum charge time, the instrument moves from Low Battery Level 1 to Low Battery Level 2 within 15 minutes, error code 29 is logged, and the instrument enters a Low Batt II condition (see Error Code 38).	Battery Capacity diminished Battery Charger circuitry Power Supply board
30	RESERVED FOR PC-2 TITRATION		
31-32	RESERVED FOR PC-2 INTEGER		
33	ROM Stack Push Error	During ROM Bank switching, a ROM stack stores the history of which ROM to return to. If this stack overflows, or the integrity is corrupted, Error Code 33 is logged and the instrument enters a watchdog condition.	Logic Board
34	ROM Stack Pop Error	During ROM Bank switching, a ROM stack stores the history of which ROM to return to. If this stack is empty or the integrity is corrupted, Error Code 34 is logged and the instrument enters a watchdog condition.	Logic Board
35	V Ref	Occurs when the main processor, through an A/D channel, is unable to read a 2.5V reference within $\pm 12\%$. "HELP INTERNAL ERROR" scrolls, audio alarm sounds, error code displays in VTBI, pumping stops and all keys except PAUSE/STOP are disabled.	Logic Board
36	Audio	Occurs when the main processor fails to detect at least 0.2V on an A/D channel following audio circuitry activation. "HELP INTERNAL ERROR" scrolls, audio alarm sounds, error code displays on VTBI, pumping continues and all keys except PAUSE/STOP are disabled.	Logic Board
37	RESERVED FOR PC-2 TITRATION		

38	Low Battery II Error	Occurs when an A/D converter reads a battery voltage below $\approx 5.15V$. "HELP BATTERY" scrolls, audio alarm sounds, pumping stops, error code displays on VTBI and all keys except PAUSE/STOP are disabled.	Battery excessively discharged. Attempt recharge for 4 hours Lead Acid Battery Power Supply Board																
39	General Software Error	Occurs when the normal calling sequence in the main software loop becomes corrupted, or a case statement index is corrupted. The error code is logged "HELP INTERNAL ERROR" scrolls, "39" displays in VTBI and "0" in RATE, audio alarm sounds, the instrument stops pumping, and all keys except PAUSE/STOP are disabled.	Logic Board																
40-47	Partition Specific NVRAM failure	<p>The non-volatile Random Access Memory (NVRAM) is divided into seven partitions, each of which has a validity check performed on it at power-up. If this check fails, a corruption of NVRAM is suspected. The code is logged, all variables in the affected NVRAM partition are initialized to default values, and the instrument is ready for normal use.</p> <p>The codes associated with each partition of NVRAM variables are:</p> <table data-bbox="848 909 1352 1127"> <tr> <td>40</td> <td>Error Log</td> </tr> <tr> <td>41</td> <td>Fixed Biotech Setup</td> </tr> <tr> <td>42</td> <td>Non-critical State</td> </tr> <tr> <td>43</td> <td>Non-critical Data</td> </tr> <tr> <td>44</td> <td>VersaTaper</td> </tr> <tr> <td>45</td> <td>Critical State</td> </tr> <tr> <td>46</td> <td>Critical Data</td> </tr> <tr> <td>47</td> <td>AutoTaper</td> </tr> </table>	40	Error Log	41	Fixed Biotech Setup	42	Non-critical State	43	Non-critical Data	44	VersaTaper	45	Critical State	46	Critical Data	47	AutoTaper	Logic Board
40	Error Log																		
41	Fixed Biotech Setup																		
42	Non-critical State																		
43	Non-critical Data																		
44	VersaTaper																		
45	Critical State																		
46	Critical Data																		
47	AutoTaper																		
48-49	RESERVED FOR PC-2 TITRATION																		

50-52	ROM Bank [1,2,3] Reset Error	When the logic processor is reset, ROM bank 0 should be the first bank accessed; if bank 1, 2, or 3 is accessed first, a ROM bank reset error has occurred and the error code is logged, "ROMx rst" will display, the audio alarm is sounded, and the instrument enters a watchdog state.	Logic Board
53	NOT USED		
54	Controller State Error	If the controller state is found to be out of range, the error code is logged, "HELP INTERNAL ERROR" displays, "54" displays in VTBI and "0" in RATE, the audio alarm is sounded, the instrument stops pumping, and all keys except the PAUSE/STOP are disabled.	Logic Board
55	NiCad Circuit failure	The NiCad circuitry is periodically validated; if a circuit failure condition is sensed, the error code is logged, "HELP INTERNAL ERROR" displays, "55" shows in VTBI and "0" in RATE, the audio alarm is sounded, the instrument stops pumping, and all keys are disabled except the PAUSE/STOP key.	Logic Board NiCad Battery
56	Event History NVRAM failure	The Event History NVRAM partition has a Cyclic Redundancy Code (CRC) calculation or a validity check performed on it at power-up. If a CRC result does not match the previous result, or the validity check fails, a corruption of NVRAM is suspected. The code is logged, all variables in the affected NVRAM partition are initialized to default values, and the instrument is ready for normal use.	Logic Board
57	Dual Charger Error	The Dual Charger timer variable is periodically range-checked; if out-of-range, the error code is logged. No audible alarm.	Power Supply Board Battery

58	Audio Channel Error	Audio software is common to both PC-1 and PC-2 (2 channel). If the PC-1 attempts to access the non-existent Channel B (existent only in the PC-2), the error code is logged, "HELP INTERNAL ERROR" displays, "58" shows in VTBI and "0" in RATE, audio alarm is sounded, the instrument stops pumping, and all keys are disabled except PAUSE/STOP. The instrument may enter a watchdog condition.	Logic Board
59	IPC State Error	Unacceptable level of inter-processor communication failures. "HELP INTERNAL ERROR" scrolls, audio alarm sounds, error code displays on VTBI, pumping stops and all keys except PAUSE/STOP are disabled.	Logic Board Display Board
60	IPC Message Error	If the logic processor determines that the display processor has been silent for 2 seconds, or if a number of IPC errors have been accumulated, the error code is logged, "HELP INTERNAL ERROR" displays, "60" shows in the VTBI, audio alarm is sounded, the instrument stops pumping, and all keys are disabled except PAUSE/STOP.	Logic Board Display Board
61	Illegal Error Code	The variable which indicates which error type has occurred is range checked before the error is logged. If the error value is found to be out of range, the value is forced to the illegal error code value. The error code is logged, "HELP INTERNAL ERROR" displays, "61" shows in the VTBI, audio alarm is sounded, the instrument stops pumping, and all keys are disabled except PAUSE/STOP.	Logic Board
62	Power-up Audio	During power-up A/D converter expects audio transducer input voltage to be >0.2VDC during audio activity. If not, "HELP INTERNAL ERROR" scrolls, audio alarm sounds, error code displays on VTBI, pumping stops and all keys except PAUSE/STOP are disabled.	Logic Board

63	Illegal ROM Bank Request	The ROM bank ID number of the intended destination ROM bank is not legal. The error code is logged and the instrument enters a watchdog condition.	Logic Board
64	NVRAM Battery	NVRAM battery voltage is <2.4 VDC for a specified period, then: "HELP BATTERY" scrolls, audio alarm sounds, error code displays on VTBI, pumping stops and all keys except PAUSE/STOP are disabled.	Logic Board NiCad Battery
65	EPROM/Software Version Mismatch	At power-up logic board processor checks version number of display processor software. If a mismatch: "HELP INTERNAL ERROR" scrolls, audio alarm sounds, error code displays on VTBI, pumping stops and all keys except PAUSE/STOP are disabled.	Wrong Display EPROM Wrong Logic EPROM
66	Slave data error	Critical values (rate, VTBI and/or language) in display processor are checked for legal range. If out of range: "HELP INTERNAL ERROR" scrolls, audio alarm sounds, error code displays on VTBI, pumping stops and all keys except PAUSE/STOP are disabled.	1st occurrence, recycle and ignore Logic Board Display Board
67	Slave segment error	Display processor detects an unacceptable voltage level on a 7 segment display. "HELP INTERNAL ERROR" scrolls, audio alarm sounds, error code displays on VTBI, pumping stops and all keys except PAUSE/STOP are disabled.	Display Board
68	TPN Time Inverse Error	The TPN timekeeping variables are safety checked against inverted duplicate copies. If there is a mismatch, the error code is logged, "HELP INTERNAL ERROR" scrolls, audio alarm sounds, error code displays on VTBI, pumping stops and all keys except PAUSE/STOP are disabled.	Logic Board
69	Slave RAM error	Display processor startup RAM test has failed. "HELP INTERNAL ERROR" scrolls, audio alarm sounds, error code displays on VTBI, pumping stops and all keys except PAUSE/STOP are disabled.	Display Board

70	Slave IPC CRC error	Display processor has received three IPC messages in a row from the 8096 containing a bad CRC. "HELP INTERNAL ERROR" scrolls, audio alarm sounds, error code displays on VTBI, pumping stops and all keys except PAUSE/STOP are disabled.	If repeated occurrence: Logic Board Display Board
71	Strain beam error	Occurs when the main processor does not detect ≥ 100 mV variance between the highest and lowest readings during any 2 revolutions of pumping mechanism. "HELP INTERNAL ERROR" scrolls, audio alarm sounds, error code displays on VTBI, pumping stops and all keys except PAUSE/STOP are disabled.	Strain Beam Logic Board
72	Motor revolution error	Actual time required to complete a pumping mechanism revolution differs from calculated value by $\pm 12\%$ for 3 revolution sample. "HELP INTERNAL ERROR" scrolls, audio alarm sounds, error code displays on VTBI, pumping stops and all keys except PAUSE/STOP are disabled.	Sticking pumping mechanism Logic Board
73	Rate corruption error	Value used to calculate motor tables does not equal redundancy check value. "HELP INTERNAL ERROR" scrolls, audio alarm sounds, error code displays on VTBI, pumping stops and all keys except PAUSE/STOP are disabled.	Logic Board
74	Motor table calculation error	Value of calculation error on motor table > 200 msec. implies a processor failure. "HELP INTERNAL ERROR" scrolls, audio alarm sounds, error code displays on VTBI, pumping stops and all keys except PAUSE/STOP are disabled.	Logic Board
75	Stuck bits error	Runtime working RAM failure, 8096 side. "HELP INTERNAL ERROR" scrolls, audio alarm sounds, error code displays on VTBI, pumping stops and all keys except PAUSE/STOP are disabled.	Logic Board

76	Motor Speed (divide by 0) Error	The motor speed variable is range-checked to prevent divide-by-zero errors. If detected, the error code is logged, "HELP INTERNAL ERROR" scrolls, audio alarm sounds, "76" displays on VTBI, pumping stops and all keys except PAUSE/STOP are disabled.	Logic Board																																	
77	Insane power-down Error	The power-down software checks to make sure that an orderly sequence of events has occurred. If not, then the error code is logged, the audio alarm sounds, and the instrument enters a watchdog condition.	Logic Board																																	
78-79	NOT USED																																			
80-89, 90-99	Detailed Insanity Errors	<p>The following startup and runtime errors result from NVRAM insanity. The specific error code is logged, "HELP INTERNAL ERROR" displays, code displays in VTBI, audio alarm is sounded, all keys are disabled except the PAUSE/STOP key.</p> <table border="1"> <thead> <tr> <th>Pwr-up</th> <th>Runtime</th> <th>Meaning</th> </tr> </thead> <tbody> <tr> <td>80</td> <td>90</td> <td>VersaTaper data error</td> </tr> <tr> <td>81</td> <td>91</td> <td>Current rate out of range</td> </tr> <tr> <td>82</td> <td>92</td> <td>Piggyback rate out of range</td> </tr> <tr> <td>83</td> <td>93</td> <td>Current VTBI out of range</td> </tr> <tr> <td>84</td> <td>94</td> <td>Piggyback VTBI out of range</td> </tr> <tr> <td>85</td> <td>95</td> <td>Tot Vol Infused out of range</td> </tr> <tr> <td>86</td> <td>96</td> <td>Sec Vol Inf out of range</td> </tr> <tr> <td>87</td> <td>97</td> <td>Motor step number out of range</td> </tr> <tr> <td>88</td> <td>98</td> <td>NOT USED</td> </tr> <tr> <td>89</td> <td>99</td> <td>Error in Rate, VTBI, etc. for MICRO mode</td> </tr> </tbody> </table>	Pwr-up	Runtime	Meaning	80	90	VersaTaper data error	81	91	Current rate out of range	82	92	Piggyback rate out of range	83	93	Current VTBI out of range	84	94	Piggyback VTBI out of range	85	95	Tot Vol Infused out of range	86	96	Sec Vol Inf out of range	87	97	Motor step number out of range	88	98	NOT USED	89	99	Error in Rate, VTBI, etc. for MICRO mode	In the event one of these errors is displayed: check NVRAM battery voltage after charging battery for ≥8 hours; if low, replace battery; if within limits, replace Logic Board.
Pwr-up	Runtime	Meaning																																		
80	90	VersaTaper data error																																		
81	91	Current rate out of range																																		
82	92	Piggyback rate out of range																																		
83	93	Current VTBI out of range																																		
84	94	Piggyback VTBI out of range																																		
85	95	Tot Vol Infused out of range																																		
86	96	Sec Vol Inf out of range																																		
87	97	Motor step number out of range																																		
88	98	NOT USED																																		
89	99	Error in Rate, VTBI, etc. for MICRO mode																																		
100-103	ROM Bank [0, 1, 2, 3] CRC Failure	If the runtime CRC does not match a "correct" CRC stored value, a corruption of ROM is suspected, and the specific error code is logged, "HELP INTERNAL ERROR" displays, code displays in VTBI, audio alarm is sounded, instrument stops pumping, all keys are disabled except the PAUSE/STOP key.	Logic Board																																	

104-106	AutoTaper Data Insanity Errors	Important AutoTaper values are checked to see that they are within their legal ranges. If not, the following error codes indicate which data is corrupted, and the specific error code is logged, "HELP INTERNAL ERROR" displays, the code displays in VTBI, audio alarm is sounded, all keys are disabled except the PAUSE/STOP key.	Logic Board
107-110	AutoTaper Context Errors	Important AutoTaper contexts are checked to see that they are within defined contexts. If not, the following error codes indicate which context is in error, and the specific error code is logged, "HELP INTERNAL ERROR" displays, the code displays in VTBI, audio alarm is sounded, all keys are disabled except the PAUSE/STOP key.	Logic Board
111-118	NOT USED		
119	Display Numbers Error	The RATE and VTBI displays are checked for reasonable values. If checks reveal invalid data, the code is logged, "HELP INTERNAL ERROR" displays, "119" displays in VTBI, audio alarm is sounded, the instrument stops pumping, and all keys are disabled except the PAUSE/STOP key.	Logic Board
120-123	Illegal ROM Bank [0, 1, 2, 3] Procedure Call	When ROM bank switching is in progress, the procedure is checked and validated. If out-of-range, the specific error code is logged and the instrument enters a watchdog condition.	Logic Board
124-125	NOT USED		
126-129	Failed to Reach ROM Bank [0, 1, 2, 3]	The ROM bank ID number of the intended destination ROM bank does not match; the specific error code is logged and the instrument enters a watchdog condition.	Logic Board
130-255	NOT USED		

Table 5-2b. PC-1 Error Log Codes (V8.xx)

The Error Codes listed below represent the results of sub-system tests initiated by software. The tests are evaluated using Pass/Fail logic with an error code generated for a fail condition.

Unless otherwise indicated, all error codes result in malfunction I/O, i.e., (1) the appropriate error code is recorded in the error log, (2) "HELP INTERNAL ERROR" is scrolled, (3) audio alarm is generated, (4) pumping is stopped, (5) all keys except PAUSE/STOP are disabled, and (6) '0' and the error code are displayed in the rate and VTBI LEDs, respectively. A malfunction condition is terminated by powering the instrument down using the PAUSE/STOP key.

Code No.	Description	Meaning	Probable Cause
00	NOT USED		
01	Error Log Reset	Marks a clearing of the error log. Initialization occurs (1) at the time of instrument manufacture and (2) when corruption of the error log is detected (typically due to a low battery condition). This error does not result in alarm I/O.	Logic Board Battery Circuit (Check voltage at RAM VCC after charging battery for at least 8 hours; if less than 2V, a NICAD battery failure is indicated)
02-05	NOT USED		
06	Battery Failure	Occurs when power-up testing of the system battery reveals voltages greater than 8 VDC or less than 5.15 VDC; causes the instrument to immediately power down without alarm.	Battery excessively discharged. Attempt recharge for 4 hours. Battery Circuit Logic Board
07	A/D Failure	Marks the failure of an expected A/D end-of-conversion interrupt to occur.	Logic Board
08	Invalid Key	Marks insanity in the Logic Processor's working image of the most recent key-press data.	Logic Board
09-12	Startup ROM CRC failures	Marks the failure of the CRC signature calculated over Logic Processor software to match that stored in ROM; causes the instrument to shut down without alarm.	Logic Board
13	Motor Sync Error	Occurs when an error exceeding 1.5% in a sample of 50 motor revolutions is detected by the motion sensor.	Pumping Mechanism Logic Board Power Supply Board

14	NOT USED		
15	Sync Flag Failure	Flagged when the motion sensor fails to confirm expected motor activity (because either the motion sensor is non-functional or the motor is not turning).	Logic Board Power Supply Board Pumping Mechanism
16-17	NOT USED		
18	Fast Battery Discharge	Marks a battery that is unable to hold a charge. After at least 1 hour of continuous operation on AC power, the instrument is required to be able to operate on battery for greater than one half the charge time; if unable to do so, error 18 is flagged: "HELP BATTERY" scrolls, audio alarm sounds, error codes 18 and 38 are logged, error code 38 is displayed in the VTBI LEDs, pumping stops, and all keys except PAUSE/STOP are disabled.	Battery Capacity Diminished Battery Charger Circuitry Power Supply Board
19	Abnormal Power-Down	Occurs following a scenario where the instrument is powered down or reset without using the PAUSE/ STOP key (i.e., following watchdog or battery failure).	Normal power-down sequence must occur to clear the condition. Logic Board Power Supply Board Battery
20	Door Circuitry Failure	Occurs when a failure of the door sensor circuitry is detected.	Logic Board Door Harness Assembly
21	NOT USED		
22	AIL Circuitry or M.A.C. Failure	Occurs when a failure of the AIL sensor is detected.	AIL Board M.A.C. AIL/Door Harness Logic Board
23	RESERVED FOR PC-1 TITRATION		
24	Startup Inverse Flag Errors	Marks the corruption of critical data expected to have been retained over power-down.	Logic Board

25	Run-time Inverse Flag Errors	Marks the corruption of data critical to run-time operation.	Logic Board
26	Battery Overcharge	Occurs when a system battery voltage in excess of 8 VDC is detected.	Power Supply Board
27-28	NOT USED		
29	Short LB1 to LB2 Time	Flagged if after a minimum charge time the instrument moves from Low Battery Level 1 to Low Battery Level 2 within 15 minutes; generates a Low Batt II (a.k.a. 'LB2') condition (see Error Code 38).	Battery Capacity diminished Battery Charger circuitry Power Supply Board
30-32	NOT USED		
33-34	Bank-switching Stack Errors	Marks stack overflow, underflow or stack pointer corruption in the stack used to control bank switching; generate watchdog conditions.	Logic Board
35	V Ref Error	Occurs when the reference voltage for the A/D converter is found to be outside the range of 2.5V \pm 5%.	Logic Board
36	Audio Failure	Occurs when the main processor fails to detect at least 0.2V of audio activity following audio circuitry activation.	Logic Board
37	NOT USED		
38	Low Battery (LB2)	Occurs when less than \approx 5.4V is read at the system battery; generates the following I/O: "HELP BATTERY" scrolls, audio alarm sounds, pumping stops, the VTBI LEDs display error 38, and all keys except PAUSE/STOP are disabled.	Battery excessively discharged. Attempt recharge for 4 hours Lead Acid Battery Power Supply Board
39	General Software Error	Marks a compound error condition with several contributing factors, all indicating that system software is not executing as programmed.	Logic Board
40-47	NVRAM Partition Failure	Marks corruption in the indicated NVRAM data partition. If the power-up validity check on any given partition fails, a partition-specific error code is logged and all data in the partition is re-initialized to default values. This error condition does not generate any alarm I/O.	Logic Board

		The partition mapping is as follows: 40 Error Log NVRAM 41 Biotech NVRAM 42 Non-critical State NVRAM 43 Non-critical Data NVRAM 44 Versa Taper NVRAM 45 Critical State NVRAM 46 Critical Data NVRAM 47 AutoTaper NVRAM	
48-49	NOT USED		
50-52	ROM Bank Reset Errors	Marks vectoring into a ROM bank other than 0 when the instrument is powered on; the error message 'ROMx rst' is displayed, where 'x' is one of 1, 2 or 3, to identify which bank was vectored into; the system goes into watchdog.	Logic Board
53	NOT USED		
54	Occlusion Detection Error	Occurs when the control variable critical to occlusion detection takes on an illegal value.	Logic Board
55	NiCad Circuit Failure	Occurs when the NiCad battery voltage is pulled abnormally low during controlled run-time load-testing.	Logic Board NiCad Battery
56	Event History Reset	Marks corruption in the Event History Log; the error code is logged and the event history is cleared. This error condition does not generate any alarm I/O.	Logic Board
57	Dual Charger Error	Flagged when dual charging has exceeded eleven hours; the error code is logged but no further recovery actions take place.	Power Supply Board Battery
58	Audio Control Error	Marks insanity in the audio control software; generates malfunction I/O, which may be followed by a watchdog condition.	Logic Board
59	NOT USED		
60	IPC Silence	Marks silence on the IPC serial link in excess of two seconds, where silence can be broken only by the receipt of well-formed messages containing valid data.	Logic Board Display Board

61	Illegal Error Code	Occurs when error log access/control software is asked to process an error code it cannot recognize.	Logic Board
62	Power-up Audio Failure	Marks a failure of the feedback circuitry to register at least 0.2VDC during startup audio testing.	Logic Board
63	Illegal ROM Bank Request	Indicates a request to switch to an unknown ROM bank; the error code is logged, then the system is forced into a watchdog condition.	Logic Board
64	NVRAM Battery Failure	Flagged when the NiCad battery is found to be below an acceptable threshold (1) during startup testing, or (2) during run-time testing after a controlled load has been applied.	Logic Board NiCad Battery
65	Software Version Error	Marks a mis-match between Logic and Display software version numbers.	Wrong Display EPROM Wrong Logic EPROM
66-67	NOT USED		
68	TPN Time Error	Occurs on corruption of VersaTaper and AutoTaper time-tracking data.	Logic Board
69-70	NOT USED		
71	Strain Beam Error	Occurs when the main processor does not detect variance greater than or equal to 100 mV between the highest and lowest readings during any 2 revolutions of the pumping mechanism.	Strain Beam Logic Board
72	Motor Revolution Error	Occurs when the actual time required to complete a motor revolution differs from the expected time by $\pm 12\%$ for 3 consecutive revolutions.	Sticking pumping mechanism Logic Board
73	Rate Corruption Error	Flagged when motor control data fails sanity cross-checks.	Logic Board
74	Motor Table Calculation error	Marks a net calculation error in the motor table in excess of 200msec for a single revolution (implying the inability of the processor to perform arithmetic operations correctly).	Logic Board
75	NOT USED		

76	Divide-by-0 Error	Flagged when a divide-by-zero operation is about to occur (the division is by-passed).	Logic Board																																	
77	Insane Power-Down	Occurs when cross-checks preceding a power-down sequence fail; the error code is logged, then the system is allowed to go into watchdog.	Logic Board																																	
78	NOT USED																																			
79	Insane Key Data	Logged when key data in a Display-to-Logic Processor IPC message has failed an internal consistency check.	Display Board Logic Board																																	
80-89, 90-97	Critical Data Sanity Errors	The following startup and run-time errors arise from NVRAM data insanity: <table border="1"> <thead> <tr> <th>Runtime</th> <th>Powerup</th> <th>Meaning</th> </tr> </thead> <tbody> <tr> <td>80</td> <td>90</td> <td>VersaTaper Step Inverse Error</td> </tr> <tr> <td>81</td> <td>91</td> <td>Primary Rate Range Error</td> </tr> <tr> <td>82</td> <td>92</td> <td>Secondary Rate Range Error</td> </tr> <tr> <td>83</td> <td>93</td> <td>Primary VTBI Range Error</td> </tr> <tr> <td>84</td> <td>94</td> <td>Secondary VTBI Range Error</td> </tr> <tr> <td>85</td> <td>95</td> <td>Total Vol Infused Range Error</td> </tr> <tr> <td>86</td> <td>96</td> <td>Sec Vol Inf Range Error</td> </tr> <tr> <td>87</td> <td>97</td> <td>Motor step Range Error</td> </tr> <tr> <td>88</td> <td></td> <td>NOT USED</td> </tr> <tr> <td>89</td> <td></td> <td>Fractional Data Range Error</td> </tr> </tbody> </table>	Runtime	Powerup	Meaning	80	90	VersaTaper Step Inverse Error	81	91	Primary Rate Range Error	82	92	Secondary Rate Range Error	83	93	Primary VTBI Range Error	84	94	Secondary VTBI Range Error	85	95	Total Vol Infused Range Error	86	96	Sec Vol Inf Range Error	87	97	Motor step Range Error	88		NOT USED	89		Fractional Data Range Error	In the event any of these errors is displayed: check NVRAM battery voltage after charging battery for 8 hours or longer; if still low, replace battery; if within limits, replace Logic Board.
Runtime	Powerup	Meaning																																		
80	90	VersaTaper Step Inverse Error																																		
81	91	Primary Rate Range Error																																		
82	92	Secondary Rate Range Error																																		
83	93	Primary VTBI Range Error																																		
84	94	Secondary VTBI Range Error																																		
85	95	Total Vol Infused Range Error																																		
86	96	Sec Vol Inf Range Error																																		
87	97	Motor step Range Error																																		
88		NOT USED																																		
89		Fractional Data Range Error																																		
98-99	NOT USED																																			
100-103	Run-time ROM CRC Failures	Marks the failure of the CRC signature calculated over Logic Processor software to match that stored in ROM.	Logic Board																																	
104-110	AutoTaper Control and Data Errors	Flagged on AutoTaper control and data Insanity.	Logic Board																																	
111-113	NOT USED																																			
114	Unexpected Startup Key Data	The display processor has sent startup key data during operation	Display Board Logic Board																																	
115-117	IPC Event Tracking	(Not errors)	N/A																																	
118	Unexpected Motor Activity	Occurs when the Display Processor senses motor activity after the Logic Processor has indicated that there should be none, i.e., when the infusion rate has nominally been set to zero.	Logic Board Display Board																																	

119	Rate/VTBI Display Data Error	Occurs when data destined for the rate or VTBI displays is out of range.	Logic Board
120-123	Illegal Bank-Switched Procedure Call	Flagged on calls to unrecognized procedures during ROM bank switching operations.	Display Board Logic Board
124-125	IPC event tracking	(Not errors)	N/A
126-129	ROM Bank Switch Failures	Mark failures of ROM bank switching operations to activate the expected bank.	Logic Board
130	Loss of the Display Processor Half-Millisecond Interrupt	Occurs when the the Display Processor interrupt mechanism is found to be non-functional.	Display Board
131-134	NOT USED		
135	Display Processor Watchdog	Flagged when the Display Processor has deliberately stopped strobing the watchdog circuitry in response to internal error conditions; places the system in watchdog with the error code in the VTBI display.	Display Board
136	Display Processor A/D Error	Marks insanity in the display Processor A/D circuit and/or its reporting mechanism.	Display Board
137	Display Processor Rate Cross-Check Error	Occurs on mis-matches between data reflecting the nominal pumping rate and the rate to be displayed; detected by the Display Processor.	Logic Board Display Board
138	Display Processor Rate Monitoring Error	Marks Insanity in the control variable for the state machine on the Display Processor which monitors motor activity.	Logic Board Display Board
139	Display Processor Software Execution Error	Flagged when the Display Processor has sensed a failure in either of its two levels of software processing.	Display Board
140	Display Processor Case Error	Occurs when the Display Processor has found a variable controlling entry to a PL/M 'case' statement to be outside its legal range.	Display Board
141	LED Segment Error	Marks a failure of the run-time 7-segment LED test.	Display Board
142	Watchdog Test Failure	Logged when the Display Processor senses a failure in the startup watchdog test.	Display Board Logic Board

143	IPC Sequence Number Error	Logged when the Display Processor has sensed a failure of the IPC message sequence numbers to be incrementing as they should, indicating a train of lost or badly-formed messages.	Display Board Logic Board
144	Run-time Display Processor ROM CRC Error	Marks the failure of the CRC signature calculated over Display Processor software to match that stored in ROM.	Display Board
145-146	Motor Revolution Error (Version 8.12 only)	Flagged when the Display Processor has determined that the motor revolution time is inappropriate for the infusion rate currently in effect.	Display Board Logic Board
147	Missing or Slow Steps	Logged when the Display Processor has detected too little stepping activity for the motor speed reported by the Logic Processor.	Logic Board Display Board
148	Air-in-Line Error	Marks detection of an air-in-line condition by the Display Processor.	Logic Board Display Board
149	Overinfusion Error	Logged when the Display Processor has detected an infusion to have continued at least 3 revolutions beyond the total number of steps indicated by the VTBI which was specified when the infusion was begun.	Logic Board Display Board
150-154	Recoverable IPC Errors	Flagged upon the receipt of illegal or insane data by the Display Processor over the IPC link (non-fatal, covered by redundancy built into the IPC protocol). 150 Display Proc. IPC Rate Data Error 151 Display Proc. IPC Motor Speed Error 152 Display Proc. IPC VTBI Data Error 153 Display Proc. IPC New VTBI Data Error 154 Display Proc. IPC Step Data Error	Logic Board Display Board
155-157	IPC Event Tracking	(Not errors)	N/A
158	(Recoverable) Display Processor IPC message CRC Error	Marks the receipt of illegal or insane data by the Display Processor over the IPC (non-fatal, covered by redundancy built into the IPC protocol)	N/A
159-160	IPC Event Tracking	(Not errors)	N/A

541

161-163	Motor Sync Error (Version 8.13 only)	Flagged when the Display Processor has determined that motor revolution times fail to reflect the nominal pumping rate reported by the Logic Processor.	Display Board Logic Board
164	Motor Rate Error (Version 8.13 only)	Flagged when the Display Processor has determined that the motor rate fails to reflect the nominal pumping rate reported by the Logic Processor.	Display Board Logic Board
165-166	IPC Event Tracking	(Not errors)	N/A
167	Motor Rate Error (Version 8.13 only)	Flagged when the Display Processor has determined that the motor rate fails to reflect the nominal pumping rate reported by the Logic Processor.	Display Board Logic Board
168	Test Fixture Mode Error	Occurs when the Display Processor has sensed a violation of the rules by which 'test fixture' mode (for manufacturing) is selected or maintained.	Logic Board Display Board
169	IPC Event Tracking only	(Not an error)	N/A
170-173	RAM Error	Flagged when critical Logic Processor data has failed sanity-checks involving inverse images and legal range.	Logic Board
174	NOT USED		
175-195	RAM Error	Flagged when critical Logic Processor data has failed sanity-checks involving inverse images and legal range.	Logic Board
196-299	NOT USED		
300	Display Processor IPC Silence	Posted when the Logic Processor has failed to communicate with the Display Processor for one second or more.	Logic Board Display Board

PC-1

Table 5-2z. PC-1 Maintenance/Diagnostic Mode Error Codes (v5.xx/6.xx/7.xx and 8.xx)

The following table lists error codes that may be generated while the instrument is being operated in Maintenance/Diagnostic Mode.

Error Code	Label	Description
0	invalid key	A key has been received that is outside the legal range.
1	Invalid wait period	Diagnostic Mode software has been asked to spin in a wait loop for a period outside the legal range.
2	mode insanity	There is confusion at the system level as to whether normal or Diagnostic Mode should be active.
3	Diagnostic Mode sequencing error	The Diagnostic Mode test sequencer control variable has taken on an unexpected value.
4	case error	Diagnostic Mode software was asked to execute a PL/M case statement whose control variable is out of legal range.
5	UART error	The UART is unexpectedly not ready for use.
6	A/D error	The A/D unit has failed to complete a requested conversion.
7	test option error	The Diagnostic Mode control software has been asked to present a test option that is outside the legal range.
8	string selection error	Diagnostic Mode software has been asked to scroll a string whose selection index is out of range.
9	C2 buffer overflow	The C2 serial communications input buffer has become full; Diagnostic Mode software is not processing data as quickly as it is coming in.

5.5 DISASSEMBLY

The following procedures are presented in a sequence that provides the most efficient means of accessing and removing the subassemblies that comprise the PC-1 pump/controller.

CAUTION

Before attempting to disassemble the PC-1 pump/controller, unplug the AC power cord from the wall outlet, remove the power cord retaining screws and disconnect the cord from the rear of the case. Check and ensure the instrument is in the power off condition. READ THE WARNING UNDER REASSEMBLY PARAGRAPH 5.6 BEFORE REATTACHING THE AC POWER CORD TO THE INSTRUMENT.

NOTE

It is recommended that all maintenance actions be performed on an anti-static surface, preferably a grounded anti-static mat.

5.5.1 Separating the Case (Figure 6-1)

Prior to removing the screws which mate the front and rear case assemblies, it is advisable to stabilize the rear case. Insert a 7 inch long piece of 1 to 1.25 inch round stock (dowel or PVC pipe) in the pole clamp so the bottom of the stock rests on the working surface. Tighten the pole clamp. This brace will prevent the rear case from falling over once the front case is detached.

NOTE

The carrying handle is retained jointly by the front and rear case handle recesses. When the instrument case is separated, the handle will fall free. The handle pad slides out of the handle extrusion.

1. Use a 5/32" Allen driver or wrench to remove the four socket head screws that connect the front and rear case assemblies. (Do not leave screws on work surface; the display windows could be damaged if front case is laid on the screws).
2. Carefully separate the front and rear case assemblies along the right side (as viewed from the front) of the instrument.
3. Disconnect the ribbon cable connector from

jack J3 on the Logic Board.

The front and rear cases are now physically and electrically separated and further disassembly can be conducted independently.

5.5.2 Front Case Disassembly (Figure 6-2b)

The following disassembly procedures are predicated on complete disassembly of the front case. Several front case assemblies are not directly accessible and require sequential disassembly for access. Those assemblies are identified with a note addressing the prerequisite procedure.

5.5.2.1 Circuit Card Removal and Disassembly (Figure 6-2b)

CAUTION

When removing, replacing or making contact with printed circuit boards, ensure the work is performed on an anti-static surface and a grounded wrist strap is used.

1. (Integer Keypad/Series V2.xx Software units serial numbers 1000-1199 ONLY) Separate the molex connector between the Nickel-Cadmium battery and the logic board and remove the battery pack from the front case.
2. Disconnect the motion sensor harness from connector J2 on the logic board.
3. Disconnect the stepper motor harness from connector J6 on the logic board.
4. Disconnect the strain beam harness from connector J5 on the logic board.
5. Disconnect the door sensor/Alt/SCD harness from connector J4 on the logic board.
6. Use a #1 Phillips screwdriver to remove the 4 screws that attach the circuit cards to the front case.
7. Carefully lift the circuit cards sufficiently to permit disconnecting the keypad cable from the display board, then remove the circuit cards from the front case.

PC-1

8. Separate connector J1 to disconnect the logic board from the display board.

5.5.2.2 Pumping Mechanism Assembly Removal (Figure 6-2b)

1. Place the front case assembly face down on the work surface. (Ensure work area is clear of foreign objects that could damage the front panel).

NOTE

If the circuit cards have not been removed, the motion sensor and stepper motor harnesses must be disconnected from jacks J2 and J6 on the logic board.

2. Use a #2 Phillips screwdriver to remove the 4 nylok screws and washers that attach the pumping mechanism assembly to the front case.
3. Lift the pumping mechanism out of the front case.

NOTES

When reinstalling the pumping mechanism, place the pumping mechanism in position and start the four mounting screws. Then push the pumping mechanism assembly to the left (looking inboard) against the mounting screws and tighten the screws to 7 lb-in.

Nylok screws that are removed in conjunction with a disassembly procedure should be replaced with new Nylok screws during reassembly. DO NOT USE ANAEROBIC GLUES SUCH AS LOCTITE 271 ANYWHERE IN THE INSTRUMENT.

A replaced mechanism should receive a run-in with a primary ate set at 5 ml/hr and a VTBI of 40 ml, and a secondary rate set at 999 ml/hr and a VTBI of 8,000 ml. Ensure that the pump is

5.5.2.3 Door Sensor Assembly Removal (Figure 6-2a)

1. Use a #1 Phillips screwdriver to remove the screw and washer that attach the door sensor

- harness retention clip to the front case.
2. Lift the door sensor from the front case recess.

5.5.2.4 AIL/SCD Assembly Removal and Disassembly (Figure 6-2a)

NOTE

Removal of the pumping mechanism (see paragraph 5.5.2.2) is required to provide access to the AIL/SCD Assembly mounting screws.

1. Use a #1 Phillips screwdriver to remove the four screws and washers that attach the AIL/SCD assembly to the front case.
2. Tilt the front case assembly to the upright position and open the door latch. This will prohibit the sear from engaging the ramped projections on the slide clamp housing.
3. Remove the AIL/SCD assembly from the front case.

5.5.2.5 Transducer Assembly Removal (Figure 6-2a)

NOTE

Removal of the pumping mechanism (see paragraph 5.5.2.2) is required to provide access to the Transducer Assembly mounting screws.

The transducer is not supported below the assembly level. DO NOT ATTEMPT TO REPAIR AND REINSTALL.

1. Use a #1 Phillips screwdriver to remove the four nylok screws and special washers (square) that attach the transducer assembly to the front case.
2. Lift the transducer assembly out of the front case.

5.5.2.6 Anchor Bracket Assembly Removal (Figure 6-2b)

1. Use pliers to grasp the spring retaining washer, press down to compress the spring then remove the hairpin cotter. Carefully

release the downward press on the spring allowing it to expand to full length. Remove the washer and spring from the anchor bracket.

2. Tilt the front case to the upright position, open the door latch, swing the door open and remove the anchor bracket.

5.5.2.7 Door Assembly Removal and Disassembly (Figures 6-2c and 6-3)

1. Unlatch and open the door.
2. Use a 1/32 inch or 1 mm drift punch to depress the tip of the upper hinge pin below the lower surface of the front case hinge pivot projection. Then ease the upper edge of the door away from the front case while using a finger to trap the hinge pin in its recess. Once the hinge pin is clear, lift the door out of the lower hinge pivot projection.

NOTE

The dowel pin that attaches the cam lock to the door is retained by a spring washer. When removed, the spring washer must be replaced.

3. Use a 1/8 inch drift punch to knock out the dowel pin that attaches the cam lock assembly (door latch) to the door.
4. Use a 1/8 inch drift punch to knock out the spring pin that attaches the sear to the cam lock.
5. Use a 1/16 inch drift punch to knock out the spring pin that attaches the cam lock pawl to the door.

5.5.2.8 Pump Seal Removal (Figure 6-1b)

1. Use a #1 Phillips screwdriver to remove the 10 screws which attach the pump seal bezel to the front case.
2. Use a fine blade, straight slot screwdriver to pry the top edge of the bezel out of the front case recess.
3. Pull the urethane pump seal from the front case.

NOTE

Prior to installing a replacement pump seal, coat the inside of the seal with 100 µl of Silicone oil (DOW 350).

5.5.2.9 Snap Bracket Removal (Figure 6-2c)

1. Use a #1 Phillips screwdriver to remove the screw that attaches the snap bracket to the front case.

5.5.2.10 Keypad/ESD Shield Assembly Removal (Figure 6-2a)

NOTE

The laminated front label/keypad/ESD shield assembly is manufactured with an adhesive backing which bonds it to the front case. Once removed, it is not reusable.

1. Perform the Anchor Bracket removal procedure to release the Keypad ESD shield.
2. Peel the laminated front label/keypad and ESD shield from front case and dispose of it.

5.5.3 Rear Case Disassembly

The following disassembly procedures are sequenced for complete disassembly of the rear case. Several rear case assemblies are not directly accessible and require sequential disassembly for access. Those assemblies are identified with a note addressing the prerequisite procedure.

5.5.3.1 Battery Removal (Figure 6-1a)

1. Lay the rear case down on the working surface.
2. Disconnect the battery harness from connector J2 on the Power Supply board.
Instruments with the Dual State Charger Modification Kit installed.
Disconnect the adapter board leads from the battery terminals.
3. Use a #2 Phillips screwdriver to remove the 2

PC-1

screws and lock washers that attach the battery retention bracket to the rear case.

4. Lift the battery out of the rear case.

5.5.3.2 Battery Bracket Removal. (Figure 6-1a)

1. Use a #2 Phillips screwdriver to remove the remaining 2 screws and lock washers that attach the battery bracket to the rear case.
2. Lift the battery bracket from the rear case.

5.5.3.3 Transformer Harness Assembly Removal (Figure 6-8)

NOTE

Removal of the battery and battery bracket is required to provide access to the transformer mounting screws. See Sections 5.5.3.2 and 5.5.3.3 above.

1. Disconnect the transformer harness from connector J5 on the power supply board.
2. Cut the shrink wrap and unsolder the black transformer wire from the terminal on the power input module and the white wire from terminal G on the fuse holder portion of the input module.
3. Use a #1 Phillips screwdriver to remove the 4 screws, washers and lock washers that attach the transformer harness assembly to the rear case.
4. Lift the transformer harness assembly from the rear case.

5.5.3.4 AC Power Input Module Assembly Removal (Figure 6-8)

1. Use a #2 Phillips screwdriver to remove the ground wire from the threaded lug on the rear case.
2. Depress the latching fingers on upper end of the module and remove it from the exterior side of the rear case.

5.5.3.4a Charger Adapter CCA Removal (Instruments with the Dual State Charger Modification Kit P/N 1310-1901-1 installed)

1. Disconnect P1 from J2 on the Power Supply Board.
2. Unsolder the blue wire from TP8 on the Power Supply Board.
3. Disconnect the wires from the battery terminals, if the battery has not been removed.

4. Use a #2 Phillips screwdriver to remove the screw that attaches the adapter board to the metal standoff.

5. Compress the fingers on the plastic standoff and lift the adapter board from the rear case.

5.5.3.5 Power Supply Board Removal

NOTE

Removal of the battery and battery bracket is required to access two of the power supply board mounting screws and to allow removal of the board. See Sections 5.5.3.2 and 5.5.3.3 above.

1. If the transformer is not removed, unplug the transformer harness from connector J5 on the power supply board.
2. Use a 1/2 inch nut driver to remove the retention nut and lock washer from the audio control potentiometer.
3. Remove the 9 screws that attach the power supply board and power transistors to the rear case.
4. Lift the power supply board from the rear case.

5.5.3.6 Pole Clamp Assembly Removal and Disassembly (Fig. 6-1a)

NOTE

The battery, battery bracket and power supply board must be removed to allow access to the four pole clamp assembly mounting screws.

1. Use a 5/32 inch Allen driver or wrench to remove the 4 screws that attach the pole clamp assembly to the rear case. The upper housing and lead screw assembly separate from the rear case.
2. Unscrew the lead screw from the wedge.
3. Remove the bumper from the knob.
4. Use a #6 straight blade screwdriver to remove the screw that attaches the knob to the lead screw.
5. Pull the knob off of the lead screw shaft.

5.5.3.7 Removal of the Power Cord Strap (Figure 6-1c)

1. Use a #2 Phillips screwdriver to remove the screw that attaches the strap and male snap to the rear case.

the instrument, ensure the male base of the power input module is clean of any electrolyte and thoroughly dry. Check the female contacts on the power cord connector for presence of any contamination; if contaminated replace the power cord.

5.5.3.8 Grounding Stud Removal

1. Use a 3/8" open end or box wrench to immobilize the grounding stud while removing the attaching nut.
2. Use a 3/8" nut driver to loosen and remove the nut that attaches the grounding stud to the rear case.
3. Remove the grounding stud.

CAUTION

When Nylok screws are removed always replace the screw with a new Nylok screw. **DO NOT UNDER ANY CIRCUMSTANCE USE ANAEROBIC GLUE, SUCH AS LOCTITE 271, TO IMMOBILIZE A SCREW.**

5.5 REASSEMBLY

The procedures for reassembly of the PC-1 pump/controller are the reverse of the preceding disassembly procedures. In those cases where a procedure(s) unique to reassembly is required, a note is provided following the last step in the disassembly procedure.

NOTES

When removal of washers is specified during disassembly, ensure that all washers are reinstalled during reassembly.

Ensure that all ground wire connections are complete before remating the front and rear case.

During reassembly, tighten all screws in accordance with the torque values set forth in Table 5-3.

WARNING

Prior to reattaching the AC power cord to

Table 5-3. Table of Torque Values

Functional Application	Item Description	Figure/Item Reference	Torque Value
FINAL ASSEMBLY			
Front Case to Rear Case	#10-32 x 3/8	6-1a /35	7 lb-in
FRONT CASE			
Multicard Assy to Front Case	#4-40 x 3/4	6-2b /120 & 160	3 lb-in
Bezel to Front Case	#4-40 x 1/2	6-2c /280	3 lb-in
Snap Bracket to Front Case	#4-4- x 3/16	6-2c /220	3 lb-in
Pumping Mechanism to Front Case	#6-32 x 3/8 Nylok	6-2a /10	7 lb-in
Transducer Assy. to Front Case	#4-40 x 1/4 Nylok	6-2a /40	3 lb-in
Door Sensor to Front Case	#4-40 x 1/4	6-2a /30	3 lb-in
AIL/SCD Assy. to Front Case	#4-40 x 1/4	6-2a /20	3 lb-in
Ground Harness to Anchor Bracket	#4-40 x 3/16	6-2b /25	3 lb-in
PUMPING MECHANISM (Applies ONLY to Instruments with 1320-1099 Pumping Mechanisms installed)			
DELETED			
REAR CASE			
Audio Harness Assy to Rear Case	#4-40 x 1/2	6-6 /50	3 lb-in
Audio Control Switch to Rear Case	Nut	6-6 /190	3 lb-in

CAUTION

When Nylok screws are removed, always replace with a new Nylok screw. Replacement screws are available from IMED Service Centers. **DO NOT UNDER ANY CIRCUMSTANCE USE AN ANAEROBIC GLUE, SUCH AS LOCTITE, TO IMMOBILIZE A SCREW.**

PC-1

5.7 CALIBRATION PROCEDURES

5.7.1 Strain Beam Calibration

Any time a Strain Beam (pressure transducer) assembly has been removed from the front case assembly or replaced, the Logic PC Board is changed or a component in the strain beam functional schematic (see figure 4-5) is replaced; the following calibration/adjustment procedure **MUST** be performed prior to returning the instrument to patient care service.

5.7.1.1 Calibration Equipment Requirements

NOTE

Calibrated tubing must be obtained from the IMED San Diego Service Center.
(IMED P/N 3299-100)

Carefully follow the special handling, installation and storage instructions provided with each calibrated tubing.

1. Calibrated tubing with specified LOW and HIGH Reference Voltage constants.
2. Digital Voltmeter with 0.1 millivolt resolution.
3. Digital Pressure Gauge, 0 - 30 psi range and 0.1 psi resolution or a Mercury (Hg) manometer.
4. Stopwatch.
5. Regulated, stable air source adjustable to 10 \pm 0.1 psi.

WARNING

The following calibration procedure is performed with the instrument case open. The preferred procedure is to perform the calibration using a fully charged battery. If AC power is used, potentially lethal voltages are present in the rear case assembly. Use caution when connecting meter leads to the Logic PC Board.

5.7.1.2 Calibration Procedures Software Releases V5.xx and V7.xx

1. Open the Main Case (see Section 5.5.1).
2. If a fully charged battery is not available, connect the AC power cord.
3. Attach the DVM positive (+) lead to output of the strain beam amplifier and ground (-) lead to the ground test point on the Logic Board.
4. Power up the instrument in the Maintenance Mode (see Section 5.3.1).

NOTE

The front case must be in the upright position when this calibration procedure is performed. DO NOT put any pressure on the pumping chamber door during the calibration process.

5. Actuate the COMPUTER CONTROL/ MONITOR switch to select the Motor Homing Test.
6. Press START, then use the Data Input Controls to select Motor Step 150.
7. Press START. When homing is complete, the encoder wheel position should match the figure below.

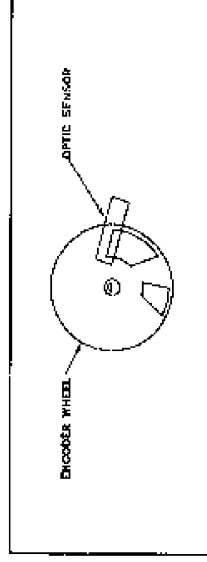

8. Actuate the COMPUTER CONTROL/ MONITOR switch to select A/D Voltage Test, then press START.
 - "strain" will appear on the Operator information display.
9. Install the calibrated disposable in the pumping chamber, close the door and wait 20 seconds. Ensure distal end is vented to ambient pressure.

10. Adjust potentiometer R24 (OFFSET) to give a stable output of 0 \pm 5.0 millivolts. Following adjustment, disconnect the DVM.
 11. Apply and maintain 10.0 \pm 0.1 psi to the distal end of the calibration disposable. Wait a minimum of 15 seconds before proceeding.
 12. Adjust potentiometer R25 (GAIN) until instrument's VTBI display reads 250 (2.50V) \pm 001 (\pm 0.01V).
 13. Adjust potentiometer R24 (OFFSET) until the VTBI display equals the sum of the calibrated disposable's zero pressure index (V_0) plus 250 \pm 5. Record the final voltage value.
 14. Release the pressure, ensuring the disposable's distal end is vented to ambient pressure.
 15. After 30 \pm 5 seconds, read the VTBI display. **This reading must equal $V_0 \pm 10$ (0.1V); if it does not, repeat steps 8 through 14.** Record the actual voltage value.
 16. Open the door and remove the calibrated disposable from the instrument. Ensure the VTBI reading drops to 000.
 17. Using your finger, gently press against the strain beam finger with sufficient pressure to fully deflect the strain beam; confirm the strain beam voltage in the VTBI display is between 490 and 515. **If the reading is not within this range, contact MED Technical Service.** Close the door.
 18. For V5.xx series software, press COMPUTER CONTROL/MONITOR then PAUSE/STOP to power down the instrument. For V7.xx series software, press COMPUTER CONTROL/MONITOR to select Powerdown Test, then press START to power down the instrument.
 19. Perform a Comprehensive Operational Performance Test (see Section 5.8).
2. If a fully charged battery is not available, connect the AC power cord.
 3. Attach the DVM positive (+) lead to output of the strain beam amplifier and ground (-) lead to the ground test point on the Logic Board.
 4. Power up the instrument in the Maintenance Mode (see Section 5.3.1).

NOTE

The front case must be in the upright position when this calibration procedure is performed. DO NOT put any pressure on the pumping chamber door during the calibration process.

5. Place your finger so that it is resting on pump fingers #3-#4-#5. Rotate the encoder wheel to feel the #3 finger withdraw, or rotate the encoder wheel until pumping fingers #9 and #10 are extended on either side of the strain beam. See the figure below:

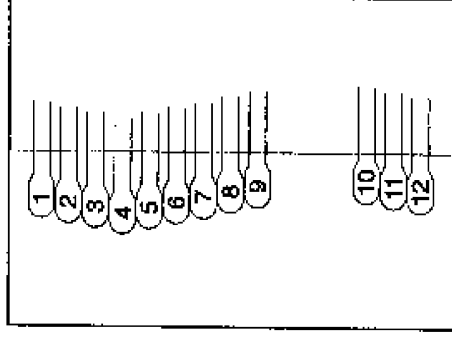

6. Actuate the COMPUTER CONTROL/MONITOR switch to select A/D Voltage Test, then press START.
 - "strain" will appear on the Operator information display.
7. Install the calibrated disposable in the pumping chamber, close the door and wait 20 seconds. Ensure distal end is vented to ambient pressure.

Software Release V6.xx

1. Open the Main Case (see Section 5.5.1).

PC-1

8. Adjust potentiometer R24 (OFFSET) to give a stable output of 0 ± 5.0 millivolts. Following adjustment, disconnect the DVM.
9. Apply and maintain 10.0 ± 0.1 psi to the distal end of the calibration disposable. Wait a minimum of 15 seconds before proceeding.
10. Adjust potentiometer R25 (GAIN) until instrument's VTBI display reads 250 ($2.50V$) ± 0.01 ($\pm 0.01V$).
11. Adjust potentiometer R24 (OFFSET) until the VTBI display equals the sum of the calibrated disposable's zero pressure index (V_0) plus 250 ± 1 . Record the final voltage value.
12. Release the pressure, ensuring the disposable's distal end is vented to ambient pressure.
13. After 30 ± 5 seconds, read the VTBI display. **This reading must equal $V_0 \pm 10$ (0.1V); if it does not, repeat steps 6 through 12.** Record the actual voltage value.
14. Open the door and remove the calibrated disposable from the instrument. Ensure the VTBI reading drops to between 002 and 000.
15. Using your finger, gently press against the strain beam finger with sufficient pressure to fully deflect the strain beam; confirm the strain beam voltage in the VTBI display is between 490 and 515. **If the reading is not within this range, contact IMED Technical Service.** Close the door.
16. Press COMPUTER CONTROL/MONITOR switch to select Maintenance V6.xx. Press PAUSE/STOP to power down the instrument.
17. Perform a Comprehensive Operational Performance Test (see Section 5.8).

5.7.2 AIL Detector Calibration

1. CALIBRATION OF THE AIR-IN-LINE DETECTOR REQUIRES SPECIAL TOOLING WHICH IS ONLY AVAILABLE AT IMED SERVICE CENTERS.

5.8 COMPREHENSIVE OPERATIONAL PERFORMANCE TEST

The comprehensive operational performance test should be performed on any PC-1 pump/controller that has been removed from service for repair or has been subjected to servicing that required the case to be opened. In the event an instrument should fail to meet specified test performance criteria, it will be necessary to troubleshoot specific areas of deficiency and perform the repairs needed to restore full operational capability prior to returning the instrument to service.

5.8.1 Electrical Inspection

CAUTION

Some of these tests are inherently hazardous. Safeguards for personnel and property should be employed when conducting such tests. Tests should only be performed by qualified personnel.

5.8.1.1 Electrical Leakage Test

Perform an electrical leakage current measurement in compliance with Underwriters Laboratories (UL) 544 for Patient Care Equipment and/or Canadian Standards Association (CSA) Standard C22.2 No. 125 for Risk Class 2G Equipment. Leakage currents are to be less than 100 microamperes.

5.8.1.2 Electrical Ground Test

Perform an electrical ground impedance measurement in compliance with UL 544 for Patient Care Equipment and/or CSA Standard C22.2 No. 125 for Risk Class 2G Equipment. The impedance between the grounding pin on the power cord plug and the grounding point on the rear case should not exceed 100 milliohms.

5.8.1.3 Dielectric Test (Optional)

Perform a dielectric withstand test in compliance with UL 544 for Patient Care Equipment and/or CSA Standard C22.2 No. 125 for Risk Class 2G Equipment.

5.8.1.4 Battery Voltage Check

Perform a battery voltage check by either entering the maintenance mode (see section 5.3 for

Maintenance Mode operating procedures) and utilizing the A/D Voltage display's system battery (sys batt) test to check the battery voltage (reading will be 1/2 true voltage), or by following the instrument disassembly procedures described in section 5.5 and connecting a volt meter across the battery terminals. Battery voltage should read >6.2 volts. Batteries installed in instruments primarily operated on battery power should be charged for 12 hours in a non-operating condition, then unplugged and allowed to stabilize for 4 hours prior to performing voltage check. Batteries testing less than 6.0 volts should be subjected to further testing or be replaced.

5.8.1.5 Battery Care and Maintenance

The IMED GEMINI PC-1 pump/controller is equipped with a 6 volt, 7.2 amp-hour lead acid battery. It is charging whenever the instrument is plugged into a 220 volt AC receptacle. The life expectancy of the battery is dependent on the amount of use, the depth of discharge, and the state of the charge that is maintained. Generally, the battery will have the longest life if the instrument is plugged in, battery use is infrequent, and depth of discharge is minimal. Heavy use of battery power will significantly decrease the life of the battery.

The battery capacity should be checked at least once every twelve months. Refer to the PC-1 Maintenance Manual, Section 5.8.3.3, for procedures.

BATTERY REPLACEMENT SHOULD BE CONDUCTED BY QUALIFIED SERVICE PERSONNEL

The quality of the battery is also a significant factor in determining battery life and runtime. The PC-1 pump/controller is originally manufactured with a Panasonic LCRSV7.2 sealed lead-acid battery. The battery cannot be repaired and should not be opened. Replace the battery with the same type, size and voltage rating. Use of any other brand may yield poor performance and is not recommended.

Ensure that the battery is installed correctly with the red connector attached to the positive (+) terminal of the battery and the black connector attached to the negative (-) terminal.

Worn out batteries should be recycled by an authorized lead-acid battery recycling center.

5.8.2 Qualitative Operational Performance Test

5.8.2.1 Operational Performance Test

The abbreviated qualitative operational performance test described in Section 2.3.3.2 will check the PC-1's keypad, audio control, displays and indicators; instrument operation in the Pump and Controller modes including those audio and visual alerts associated with normal instrument operation and the instrument power down sequence.

Software Release V6.xx

5.8.2.2 VTBI Display Validity Check

Following replacement of a battery, logic CCA or EPROM, perform the following check:

1. Press POWER ON control to initialize the instrument.
2. Press VTBI control.
3. Press the "1" data entry control and check:
 - VTBI displays incremented value:
 - a. if the units digit display increased by 1, no further action is required
 - b. if the tens digit display increased by 1, proceed to step #4.
4. Press PAUSE/STOP control once to power down the instrument.
5. Reinitialize the instrument in either the MICRO or MACRO mode by pressing and holding the "0.1" or "100" control respectively.
6. Press VTBI control, then press the "1" data entry control and confirm the VTBI units digit increments by 1.

5.8.3 Quantitative Operational Performance Test

The following operational performance tests are designed to ensure the PC-1 pump/controller is functioning in accordance with design specifications. Test procedures are provided to evaluate specific areas of instrument performance.

5.8.3.1 Equipment Requirements

1. Universal test station, including: (see Figure 5-1).
 - Selector valve manifold

PC-1

- 10 or 50 mL Volumetric burette
- Pressure gauge, at least 0-20 psig, accurate within 2.0% or better
- 36" view tube (macro bore tubing on yard stick).

2. Air-in-line simulator (see Figure 5-2)
3. Stopwatch with minimum resolution of 1 second.
4. Vented bottle or bag of Normal Saline.
5. GEMINI Vented/Non-vented Administration set with 2 injection sites (e.g. 2220).
6. Waste fluid catch basin.
7. Test Data Sheet (see Figure 5-3).

8. Hemostat.

5.8.3.2 Initialization Setup

INITIAL SETUP

1. Mount pump on IV pole (leave AC power cord unplugged).
2. Fill IV fluid container with water and hang on IV pole 24" (61 cm) above the PC-1 instrument.
3. Spike and prime administration set.
4. If available, attach ECD sensor to the set drip chamber (do not connect to ECD receptacle until instructed).









5. Press POWER ON Control and check
 - Battery Operation Indicator - illuminated
 - RATE and VTBI displays show ("888.8").
 - All LED indicators illuminate momentarily then extinguish, except the delivery mode/operating indicator for the previously selected delivery mode and a "0", "0.0" or "000" in the units digit of Rate and VTBI displays.
 - "PC-1 Vx.xx" message scrolls once across the Status/Alarm Display (x.xx = software version).
 - A single audio Prompt sounds.



- "SELECT P/C MODE" message scrolls once (if the P/C Mode select is unlocked) followed by continuous scroll of the "SET RATE" message. After 12 seconds the Prompt audio sounds.







Titration Keypad/Series v7.xx and V8.xx Software



5. Press and hold the VOL INF control, then press POWER ON and check:
 - Battery Operation Indicator - illuminated.
 - RATE and VTBI Displays show "888.8" momentarily then extinguish.
 - All LED indicators and dot-matrix elements illuminate momentarily then extinguish.
 - A single audio Prompt is sounded.
 - "setup PC-1 v7.xx or v8.xx press setup control" scrolls continuously (x.xx = installed software version).

6. Check or set instrument configuration:

- a. Press VOL INF control - "tamper-resistant mode" scrolls continuously
 - Press START - "enabled" or "disabled" displays statically.
 - Use either the  or  control to select "disabled" setting.
- b. Press VOL INF control - "P/C mode" scrolls continuously
 - Press START - "locked" or "unlocked" displays statically on the Operator Information display.
 - Selected Delivery mode/operating indicator illuminates.
 - Use either the  or  control to select "unlocked" setting.
- c. Press VOL INF control - "10 psi mode" or "517 mmHg" (v8.13 only) scrolls continuously
 - Press START - "enabled" or "disabled" displays statically.
 - Use either the  or  control to select "disabled" setting.
- d. Press VOL INF control - "macro/micro mode" scrolls continuously
 - Press START - "macro", "micro" or "mic/mac" displays statically.
 - Use either the  or  control to select "mic/mac".

- e. Press VOL INF control - "Primary switchover alert mode" scrolls continuously
- Press START - "enabled" or "disabled" displays statically.
 - Use either the  or  controls to select "enabled".

- f. Press VOL INF control - "communications setup" scrolls continuously
- Press START - "serial #" displays statically.
 - Use 1, 10, 100 and/or CLEAR/SILENCE controls to input serial number.
 - Press PAUSE/STOP - "baudrate" displays statically.
 - Use either the  or  control to select baudrate (110, 300, 600, 1200, 2400, 4800 or 9600).
 - Press PAUSE/STOP - "parity" displays statically.
 - Use either the  or  control to select parity option (O [odd], E [even] or OFF).
 - Press PAUSE/STOP - "stopbits" displays statically.
 - Use either the  or  controls to select stop bit option (1 or 2).

- g. Press VOL INF control - "language selection" scrolls continuously
- Press START - currently selected language displays statically.
 - Use either the  or  control to select language option (english, german, french, italian, swedish, spanish).

- h. Press VOL INF control twice "exit setup" scrolls continuously.

- i. Press START to exit setup and enter infusion Setup and Operation mode
- Battery operation LED flashes
 - Rate and VTBI displays show

CHARGING INDICATION

1. Connect AC Power cord to a 120 VAC (or 220VAC where appropriate) power source and check:
 - AC Power Indicator - illuminates.
 - Battery Operation Indicator - extinguishes.
2. Unplug AC Power cord from the AC power source and check:
 - AC Power Indicator - extinguishes.

- Six pulses of the audio Alarm - sound [v2.xx/5.xx/6.xx ONLY].
- Battery operation indicator - illuminates [v2.xx/5.xx/6.xx ONLY] - flashes [v7.xx and subsequent].

3. Reconnect the AC Power cord to the AC power source.

5.8.3.3 Pump Mode Tests

The following test procedures are presented in a sequence that will allow the required test protocols to be accomplished accurately and in an expeditious and efficient manner.

TEST SETUP

1. Spike a vented bottle or bag of Normal Saline or tap water with a GEMINI Vented/Non-vented Administration set and hang on the IV solution test stand. Check that the roller clamp is closed.
2. Connect the distal end of the tubing set to the input side of the stopcock manifold.
3. Set the stopcocks to allow fluid to pass through the manifold to the fluid catch basin.
4. Flood the drip chamber, open the roller clamp, prime the set then close stopcock #2.
5. Adjust the height of the solution container to provide a measured head height of 24" (61cm); i.e., 24" of vertical displacement between the strain beam and the fluid level in the container.
6. Set the lower end of the burette level with or slightly higher than the instrument's strain beam.
7. Press POWER ON control.
8. Install the tubing set in the PC-1 pump/controller; close and latch the door.
9. Ensure the tubing segment between the stopcock manifold and the pressure gauge is primed.
10. Select CONTROLLER mode, set RATE to 125 mL/hr and set VTBI to 100 mL.

PC-1

LOW-FLOW HEAD HEIGHT TEST

1. Turn stopcock #3 to direct the pump output to the 36" view tube only. Ensure the 18" mark on the view tube is level with the fluid in the solution container.
2. Press START and observe:
 - Fluid column rises in the view tube.
 - Pumping mechanism stops.
 - Audio Advisory sounds.
 - "LOW FLOW" advisory scrolls for 1 minute.
3. Record the height of the fluid column in the view tube on the data sheet (reading must be between 6 and 30 inches).
4. Silence alarm, then press PAUSE/STOP once.
5. Turn stopcock #3 to drain the fluid column to waste; drain to the 0 graduation, then turn the stopcock to the bypass position.

OUTPUT PRESSURE TEST

1. Turn stopcock #1 to direct pump output to the pressure gauge.
2. Select PUMP mode.
3. Press START and observe:
 - Pumping mechanism stops.
 - Audio Alarm sounds.
 - "OCCLUDED-PATIENT SIDE" scrolls continuously.
4. Record pressure gauge reading on the data sheet immediately following alarm (reading must be between 8 and 12 psi).
5. Silence alarm, then press PAUSE/STOP once.
6. Turn stopcock #1 to the bypass position.
7. Press START control and check:
 - Pump mode operating indicator - flashes.
8. Use the hemostat to close off the proximal tubing and check:
 - "OCCLUDED-FLUID SIDE" alarm - scrolls.
 - Pump mode ALARM indicator - flashes.
 - Alarm audio - sounds.
 - Pumping mechanism - stops.

9. Clear occlusion (remove hemostat), then press START and check:

- Pumping mechanism - operates.
- Operating indicator - flashes.
- Press PAUSE/STOP twice.

MAXIMUM PRESSURE TEST

1. Initialize instrument in the Maintenance Mode.
2. Press COMPUTER CONTROL/MONITOR switch to select "pump test".
3. Press START control twice.
4. Verify rate set to 125 mL/hr and VTBI >25 mL.
5. Press START control and allow the pump to operate for at least 30 seconds and wait until the peak pressure stabilizes.
6. Record the highest pressure reading obtained. **Resultant pressure must be ≥ 17 psi.**
7. Press PAUSE/STOP control twice to power down the instrument.
8. Turn the Test Station stopcock #1 to the bypass position.

VOLUME/RATE/TIME TEST

1. Turn stopcock #2 to direct fluid flow to the 10 mL burette.
2. Press START to fill the burette to the 10 mL line, then press PAUSE/STOP once.
3. Press VOLUME INFUSED followed by CLEAR to reset the Volume Infused register to "0".
4. Set VTBI to 5 mL and verify the RATE is set to 125 mL.
5. Press START and start the stopwatch simultaneously.
6. When audio Advisory sounds and "INFUSION COMPLETE-KVO" scrolls, immediately stop the stopwatch and press PAUSE/STOP twice.

NOTE

Failure to stop the pump immediately will induce a volume accuracy error into the test.

7. Read the fluid level in the burette.

8. Record the volume delivered (10 mL minus fluid level from step #7) and elapsed time on the data sheet. (Volume delivered must be between 4.75 and 5.25 mL and elapsed time must be within 2:16 and 2:31 {min:sec} limits).

9. Turn stopcock #2 to drain the fluid in the burette down to the 10 mL line.

AIR IN LINE TEST

1. Open the access door and remove the administration set.

2. Install the pumping segment of the AIL simulator (see Figure 5-2) into the pumping mechanism, then press the tubing into the AIL detector.

3. Push the slide clamp in (the instrument will auto power on in Alarm mode).

4. Use the AIL simulator plunger to raise the fluid level to the top of the slide clamp fitment.

5. Close the door.

6. Set the rate to 125 mL/hr and VTBI to 50 mL and press START.

7. Use the AIL simulator plunger to draw the fluid level below the AIL detector.

8. Verify that within 2 seconds the PC-1 pump/controller goes into AIL alarm:

- Pumping stops.
- Operating LED indicator stops flashing.
- Alarm audio sounds.
- Alarm LED flashes.
- Channel Information display scrolls "AIR IN LINE".

9. Press PAUSE/STOP to power down.

BATTERY CAPACITY CHECK

Battery operation with a new, fully charged battery is ≈5 hours with the instrument operating at 125 mL/hr. Under conditions of normal usage (e.g., one discharge cycle/day), the battery should retain 50% of its original capacity after one year of usage.

Usage other than that described above may result in prolonged or reduced battery life (i.e., more than one discharge/day without a complete recharge may reduce battery life).

To determine battery capacity, perform the following procedure:

1. Connect the AC power cord to an AC source and allow the battery to charge for 16 hours with the instrument not operating.
2. Disconnect from the AC source and operate the instrument at 125 mL/hr.
3. Record the battery-operated run time to the point of activation of the "HELP BATTERY" alarm.
4. If the resultant run time is less than 2.5 hours, consideration should be given to replacing the battery. Follow your hospital protocol for battery replacement.

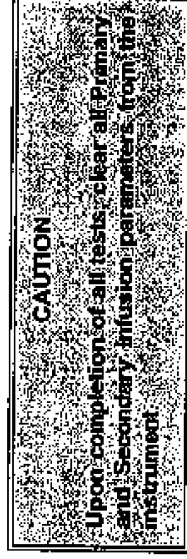

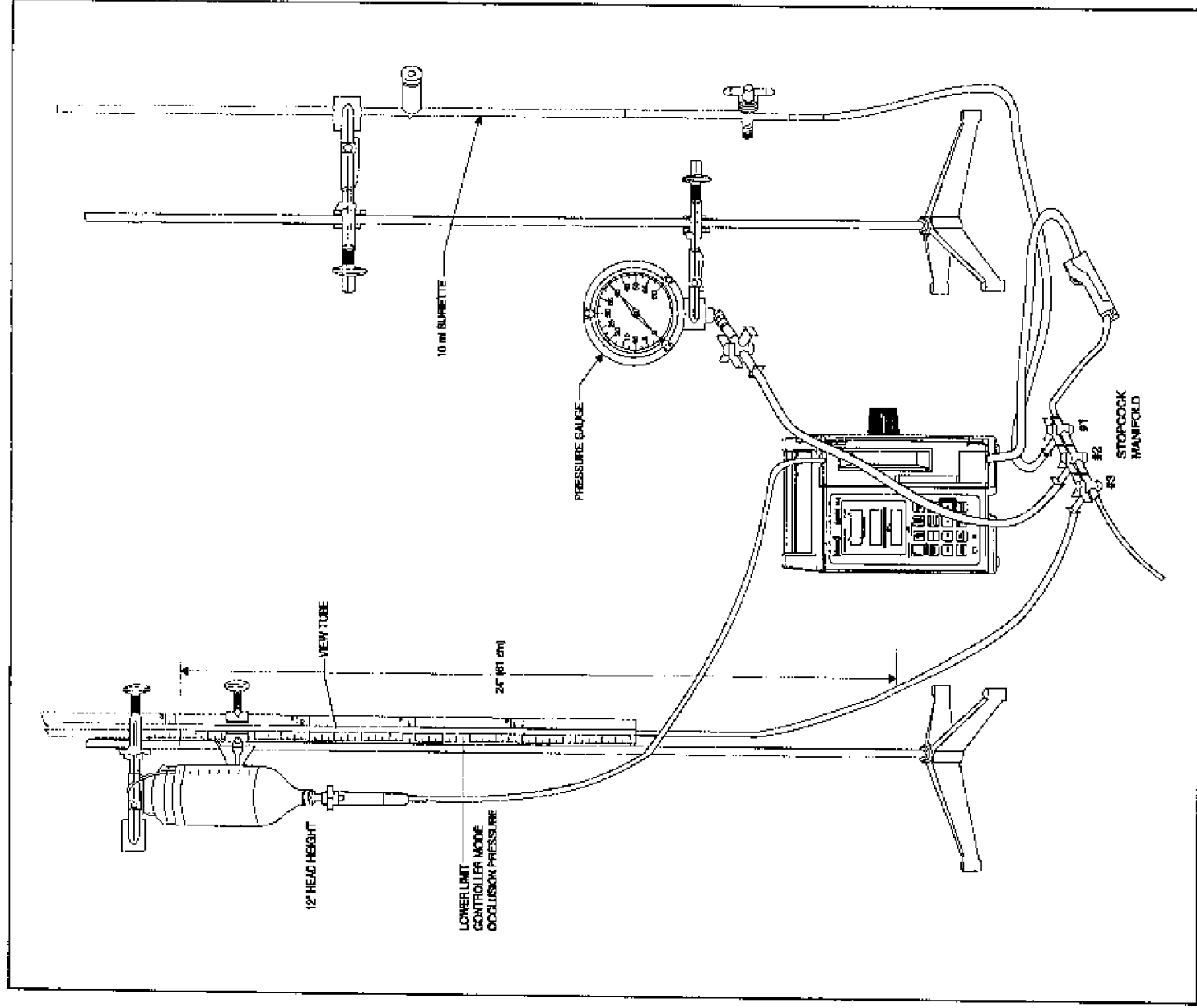

Figure 5-1. Universal Test Station Setup

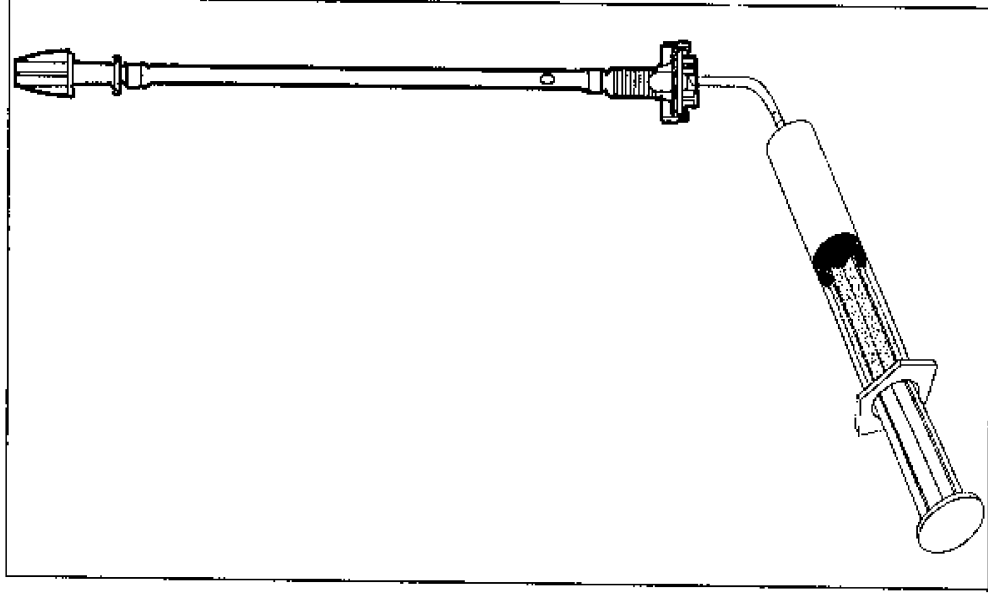

Figure 5-2. Air-In-Line Simulator

PC-1

PC-1 PUMP/CONTROLLER TEST DATA SHEET

Instrument Serial No. _____ Software Version _____

Date _____ Technician _____

Test No.	Description	Reference	Record Result	Pass/Fail
1	Mechanical Inspection	5.2.2	_____	Pass___/Fail___
2	Electrical Leakage Test	5.8.1.1	_____	Pass___/Fail___
3	Electrical Ground Test	5.8.1.2	_____	Pass___/Fail___
4	Initialization	5.8.3.2	_____	Pass___/Fail___
6	Pump Mode Tests	5.8.3.3	_____	Pass___/Fail___
	• LOW FLOW HEAD HEIGHT TEST	5.8.3.3	_____	Pass___/Fail___
	• OUTPUT PRESSURE TEST	5.8.3.3	_____	Pass___/Fail___
	• MAXIMUM PRESSURE TEST	5.8.3.3	_____	Pass___/Fail___
	• VOLUME/RATE/TIME TEST	5.8.3.3	_____	Pass___/Fail___
	• AIR-IN-LINE/SLIDE CLAMP DETECTOR	5.8.3.3	_____	Pass___/Fail___
	• BATTERY CAPACITY CHECK	5.8.3.3	_____	Pass___/Fail___

PC-1 PUMP/CONTROLLER OPTIONAL TESTS

These tests are to be performed at the discretion of the repairing facility

Test No.	Description	Reference	Record Result	Pass/Fail
1	Dielectric Test	5.8.1.3	_____	Pass___/Fail___
2	Maintenance/Diagnostic Mode Test	5.3	_____	Pass___/Fail___
3	ECD Test (When Applicable)	Page 3-15	_____	Pass___/Fail___

Figure 5-3. PC-1 Pump/Controller Test Data Sheet

SECTION 6 - ILLUSTRATED PARTS BREAKDOWN

6.1 INTRODUCTION

The tables and figures presented in this section identify the sub-assemblies and list the component parts of each sub-assembly in the GEMINI PC-1 Volumetric Pump/Controller. Any part listed without an accompanying part number is not field-replaceable, and is available only as an integral part of the next higher assembly.

NOTE

Use of parts procured from sources other than ALARIS Medical Systems will void the product warranty (see Section 7).

Each tabular listing of parts is supplemented with either an exploded view illustration of the respective assembly or a component location diagram. These drawings are provided solely for use by biomedical technicians and engineers to service, maintain and/or repair the PC-1 pump/controller. Customers experiencing repair requirements beyond their local capability are encouraged to return those items or assemblies to ALARIS Medical Systems for repair or replacement. The ALARIS Medical Systems' Service Department maintains facilities to troubleshoot, repair and test all PC-1 pump/controller integrated circuit boards.

In the event difficulty is encountered in identifying any part, ALARIS Medical Systems' Customer Service Department should be contacted by telephone, fax or letter for assistance.

PC-1

Table 6-1. Parts List - PC-1 Final Assembly

Fig No/Item	Qty	Description	Part No	Reference
	X	PC-1 Final Assembly Eng V7.xx	1310-1136-4	
	X	PC-1 Final Assembly Span V7.xx	1310-1136-5	Alt to -4
	X	PC-1 Final Assembly Fren V7.xx	1310-1136-6	Alt to -4
6-1a	1	Ham Assy, Universal Battery	1310-1101-1	
6-1a	1	Rear Case Assembly, Titration	1310-1114-1	
6-1b	1	Front Case Assembly, Titration	1310-1134-4	
	1	Front Case Assembly, Titration, Fgn	1310-1134-5	Alt to Item 45
6-1c	1	Power Cord Wrap Assembly	980-1015-1	
6-1c	1	Label Kit, Rear PC-1	1310-1158-7	Alt to Item 70
	1	Label, Nameplate	1310-2096-7	Alt to Item 70
	1	Label, ECD/Comm./Audio 119V	1310-2018-7	Alt to Item 70
	1	Label, UL and CSA 119V	1310-2024-7	Alt to Item 70
6-1b	1	Label, Factory Seal	822-2027-7	
6-1b	1	Label, Serial No.	960-2106-7	
6-1b	1	Label, Operator Instructions	1310-2013-7	
6-1b	1	Label, Generic Warning	1320-2358-7	
6-1a	1	Label, Battery History	1310-2101-7	
6-1a	1	Label, Battery Spec PC-1	1310-2126-7	
6-1c	1	Hood, A/C Receptacle	1310-2037-7	
6-1a	1	Battery Bracket	1310-2065-7	
6-1b	1	Label, Close Roller Clamp Warning	1320-2407-7	
6-1c	1	Cable, Ribbon 50 CKT	1310-3009-1	
6-1c	1	Power Cord, Universal	1320-3036-7	
6-1b	1	Handle, PC-1	1310-2008-7	
6-1b	1	Pad Insert, PC-1 Handle	1310-2009-7	
6-1a	6	Bumper Strip, 1/2 x 1/8 x 1	809095	
6-1a	1	Battery, 7.2 AH, Panasonic	841027	
6-1b	4	Bumper, Rubber	809002	
6-1c	1	Stud, Brass Snap	809061	
6-1a	4	Screw, Mach, 8-32x.50, XREC, PNH	801008	
6-1c	3	Screw, #4-40x3/8 PNH/RND	801003	
6-1c	1	Screw, #6-32 UNC x 3/8 FLT HD	801116	
6-1a	4	Screw, #10-32 UNF x 3/8 SOC HD	801326	
6-1a	3	Lock Washer, Spr, Spt, 8, Sll	803208	
6-1a	A/R	Tape, Vinyl .004 x 1, one side	830022	
6-1b	A/R	Cord, Seal Conductive	834042	
6-1a	A/R	Tape, Glass Cloth, Elect Type	830020	

Table 6-1a. Parts List - PC-1 Final Assembly
(Special 220V Parts & Labels)

220V

Fig No/Item	Qty	Description	Part No	Reference
	X	<u>PC-1 Final Assembly, V7.xx</u>	1310-1170-1	English
	X		1310-1170-6	Australia
	X		1310-1170-2	French
	X		1310-1170-3	Swedish
	X		1310-1170-4	Spanish
	X		1310-1170-5	Italian
	X		1310-1150-2	German (TUV)
	X	<u>PC-1 Final Assembly, V8.xx (CE)</u>	1310-1172-1	English
	X		1310-1172-2	French
	X		1310-1172-3	Swedish
	X		1310-1172-4	Spanish
	X		1310-1172-5	Italian
	X		1310-1172-6	Australia
	X		1310-1172-7	German
	1	<u>Rear Case w/Acme Pole Clamp Assembly</u>	1310-1160-1	
	1	<u>Front Case Vac Metalized w/Inserts</u>	1310-2058-10	
	1	<u>Nameplate Labels V7.xx</u>	1310-2108-7	BSI
	1		1310-2113-7	French
	1		1310-2114-7	Swedish
	1		1310-2122-7	German
	1		1310-2124-7	Spanish
	1		1310-2137-7	Italian
	1	<u>Nameplate Labels V8.xx (CE)</u>	1310-2144-7	English
	1		1310-2144-8	French
	1		1310-2144-9	Italian
	1		1310-2144-10	Swedish
	1		1310-2144-11	Spanish
	1		1310-2144-12	German
	1	<u>Audio & Comm Labels V7.xx</u>	1310-2112-7	Swedish
	1		1310-2121-7	German
	1		1310-2138-7	Italian
	1	<u>Audio & Comm Labels V8.xx (CE)</u>	1310-2146-7	English
	1		1310-2146-8	French
	1		1310-2146-9	Italian
	1		1310-2146-10	Swedish
	1		1310-2146-11	Spanish
	1		1310-2146-12	German
	1	<u>Operator Instructor Labels</u>	1310-2043-7	French
	1		1310-2042-7	Swedish
	1		1310-2123-7	Spanish
	1		1310-2136-7	Italian
	1		1310-2119-7	German

PC-1

Fig No/Item	Qty	Description	Part No	Reference
	1	<u>Generic Warning Labels</u>	1320-2358-8	French
	1		1320-2358-10	Swedish
	1		1320-2358-11	Spanish
	1		1320-2358-9	Italian
	1		1320-2358-12	German
	1	<u>Close Roller Clamp Warning Label</u>	1320-2407-8	French
	1		1320-2407-11	Spanish
	1	<u>Label, Homologation</u>	1310-2131-7	French
	1	<u>Label, Warning IV Set</u>	1310-2128-7	German
	1	<u>Gasket, Communications, PC-1 V8.xx (CE)</u>	1310-2147-7	
		<u>Power Cords</u>		
	1	Power Cord, 5AMP, U.K.	848009	English
	1	Power Cord, Australia 220/240V	848012	Australia
	1	Power Cord, Continental Europe	848008	French-Swedish- Spanish-Italian- German

PC-1

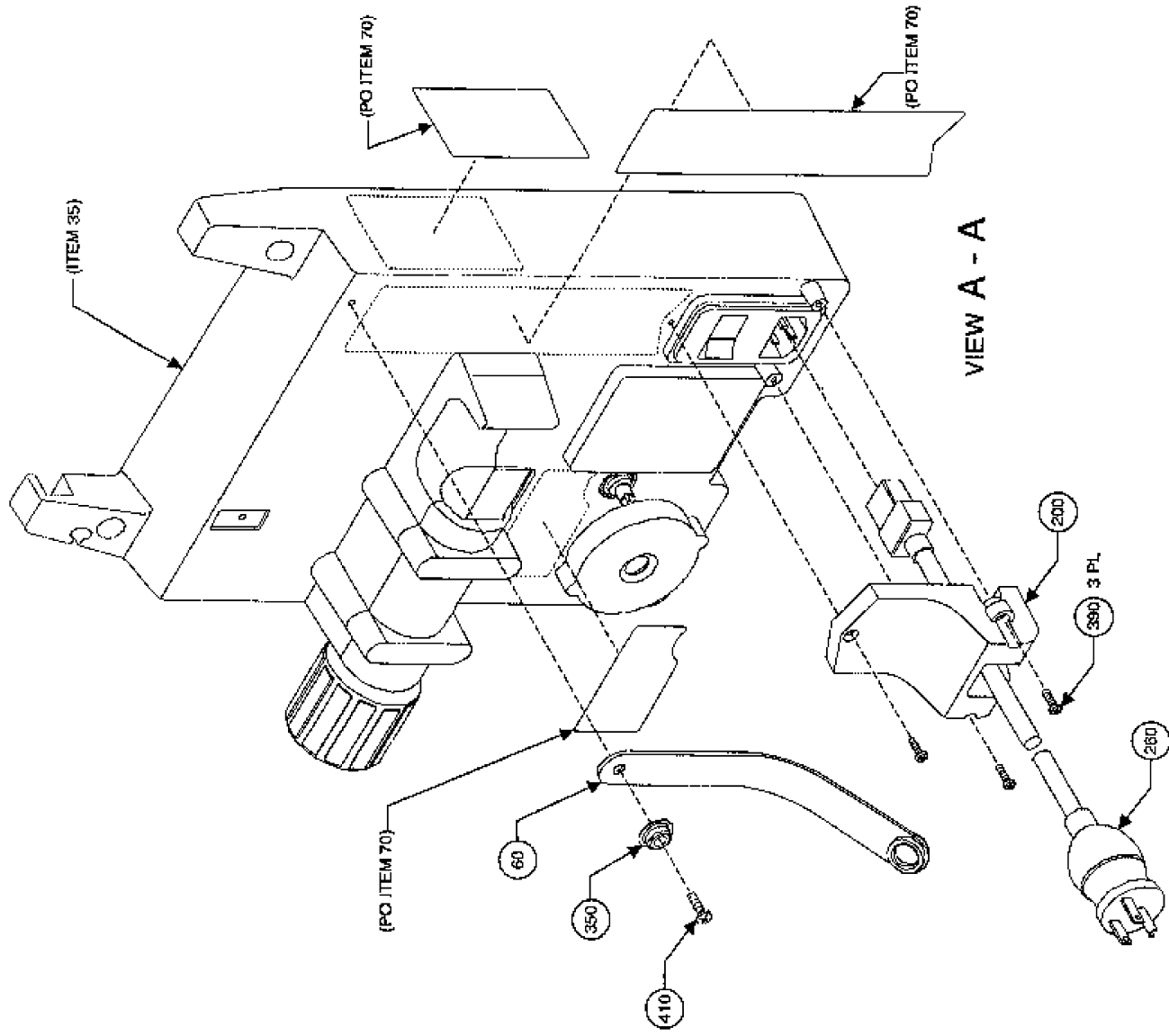

Figure 6-1c. Parts Identification PC-1 Final Assembly

PC-1

Table 6-2. Parts List - Front Case Assembly

Fig No/Item	Qty	Description	Part No	Reference
6-1b	45	Front Case Assembly (Titration V7.11)	1310-1134-4	Alt to -4
	1	Front Case Assembly	1310-1134-5	
6-2c	355	Front Case Vac Mltz w/inserts (220V)	1310-2058-10	
6-2a	10	Pumping Mechanism Asmblly, w/MAC	1310-1132-2	
6-2a	20	AIL Housing Assembly	1340-1026-1	
6-2b	25	Keyboard Ground Cable	1320-1072-1	
6-2a	30	Door Sensor Assembly	1320-1243-1	
6-2a	40	Transducer Assembly w/UV coating	1320-1194-2	
6-2c	70	Right Outer Door Assembly	1320-1288-4	
6-2a	80	Top Plate Assembly, MAC	1310-1164-1	
6-2b	120	CCA, Display, PC-1T, V7.11	1310-7033-3	Also -5 Alt to item 120 Alt to item 120 Alt to item 160 Alt to item 160 Also -5
	3	CCA, Display, German (TUV) (220V)	1310-7041-2	
	1	CCA, Display, PC1, CE	1310-7044-1	
	1	CCA, PC-1T, German (TUV) (220V) Logic	1310-7040-2	
	1	CCA, PC1, CE	1310-7046-1	
6-2b	160	CCA, PC-1T, Logic Analog, V7.11	1310-7026-2	
6-2b	180	Anchor Bracket Tapered	1320-2198-10	Alt to item 310 Alt to item 310 Alt to item 310 Alt to item 310 Alt to item 310
6-2b	190	Anchor Bracket Roller	1320-2150-7	
6-2a	210	Mounting Bracket Hall Sensor	1320-2145-7	
6-2c	220	Snaps Bracket	1320-2103-7	
6-2a	230	Mechanism Alarm Circuit Asmblly, Upper, 13"	1310-3045-1	
6-2a	240	Mechanism Alarm Circuit Asmblly, Lower, 7"	1310-3046-1	
6-2a	260	AIL Gasket	1310-2094-7	
6-2c	280	Pump Seal, Urethane	1320-2284-7	
6-2c	290	Bezel Seal, Retaining	1320-2121-7	
6-2c	310	AIL Label	1320-2369-7	
6-2a	340	AIL Label, PC-1, German, (220V)	1310-2127-7	Alt to item 340 Alt to item 340 Alt to item 340 Alt to item 340 Alt to item 340 Alt to item 340 Alt to item 340 Alt to item 340 Alt to item 340 Alt to item 340
	1	AIL Label, PC-1, French, (220V)	1310-2133-7	
	1	AIL Label, PC-1, Swedish, (220V)	1310-2169-7	
	1	AIL Label, PC-1, Spanish, (220V)	1310-2132-7	
	1	AIL Label, PC-1, Italian, (220V)	1320-2369-9	
	1	Keypad, PC-1T, Frac Rate, English	1310-3030-7	
	1	Keypad, PC-1T, No Graphics (220V)	1310-3030-8	
	1	Keypad Overlay, German (220V)	1310-3040-7	
	1	Keypad Overlay, French (220V)	1310-3035-7	
	1	Keypad Overlay, Swedish (220V)	1310-3034-7	
	1	Keypad Overlay, Spanish (220V)	1310-3039-7	
6-2c	370	Keypad Overlay, Italian (220V)	1310-3044-7	Alt to item 340 Alt to item 340 Alt to item 340 Alt to item 340 Alt to item 340 Alt to item 340 Alt to item 340 Alt to item 340 Alt to item 340 Alt to item 340
	2	Hinge Pin Gemini	1320-2105-7	
6-2a	381	Screw, Mach, 6-32 x .38, PNH	801062	
6-2a	391	Screw, Mach, 4-40 x .31, PNH	801063	
6-2a	400	Spacer, Stainless Steel #4	1320-3043-7	
6-2b	420	Rubber Burrper	809002	
6-2a	430	Cable Clamp, Nylon w/adhesive, 1/8 dx	845023	
6-2a	440	Cable Clamp, Nylon w/adhesive, 1/4 dx	845024	

Table 6-2. Parts List - Front Case Assembly (Cont'd)

Fig No/Item	Qty	Description	Part No	Reference
6-2b 470	1	Cotter Pin, 1/4 x 1.0 Spring w/zinc	804201	
6-2b 480	1	Dowel Pin, 3/32 x .50, SST	804001	
6-2b 520	4	Retaining Spacer, .25	805039	
6-2c 530	1	Door Spring, 2.5 lb/in SST	809039	
6-2b 540	1	Spring, CPRSN 13.2 lb/in	809088	
6-2c 590	10	Screw, Self Tapping, 4-40 x .37, F, PHH, Flat	801427	
6-2a 600	10	Screw, Self Tapping, 4-40 x .37, T, XREC, 82	801424	Alt to item 590
6-2b 610	5	Screw, Mach, 4-40 x .25, XREC, PNH	801002	
6-2b 620	2	Screw, Mach, 4-40 x .18, XREC, PNH	801042	
6-2a 690	4	Screw, Mach, 4-40 x .62, XREC, PNH	801044	
6-2a 700	5	Washer, Flat, 4, Carbon Stl, Galv	803000	
	4	Washer, Flat, 6, Carbon Stl, Galv	803002	
6-2c 710	1	Washer, Flat, 10	803026	
6-2b 720	2	Washer, 1/4" I.D., 1/2" O.D., SS	803619	
6-2a 750		Tie Cord	834000	
6-2a 770		Cable Tie	834031	

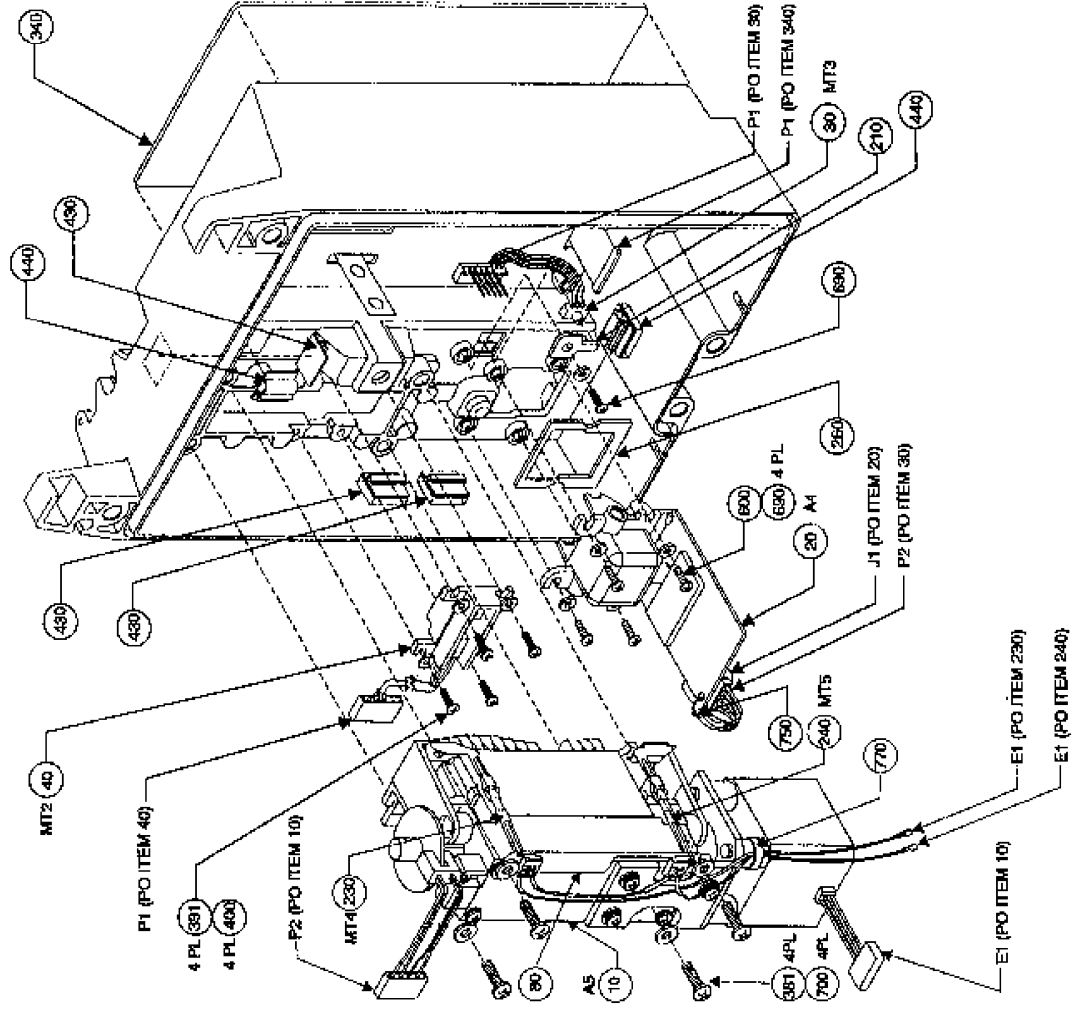

Figure 6-2a. Parts Identification Front Case Assembly

PC-1

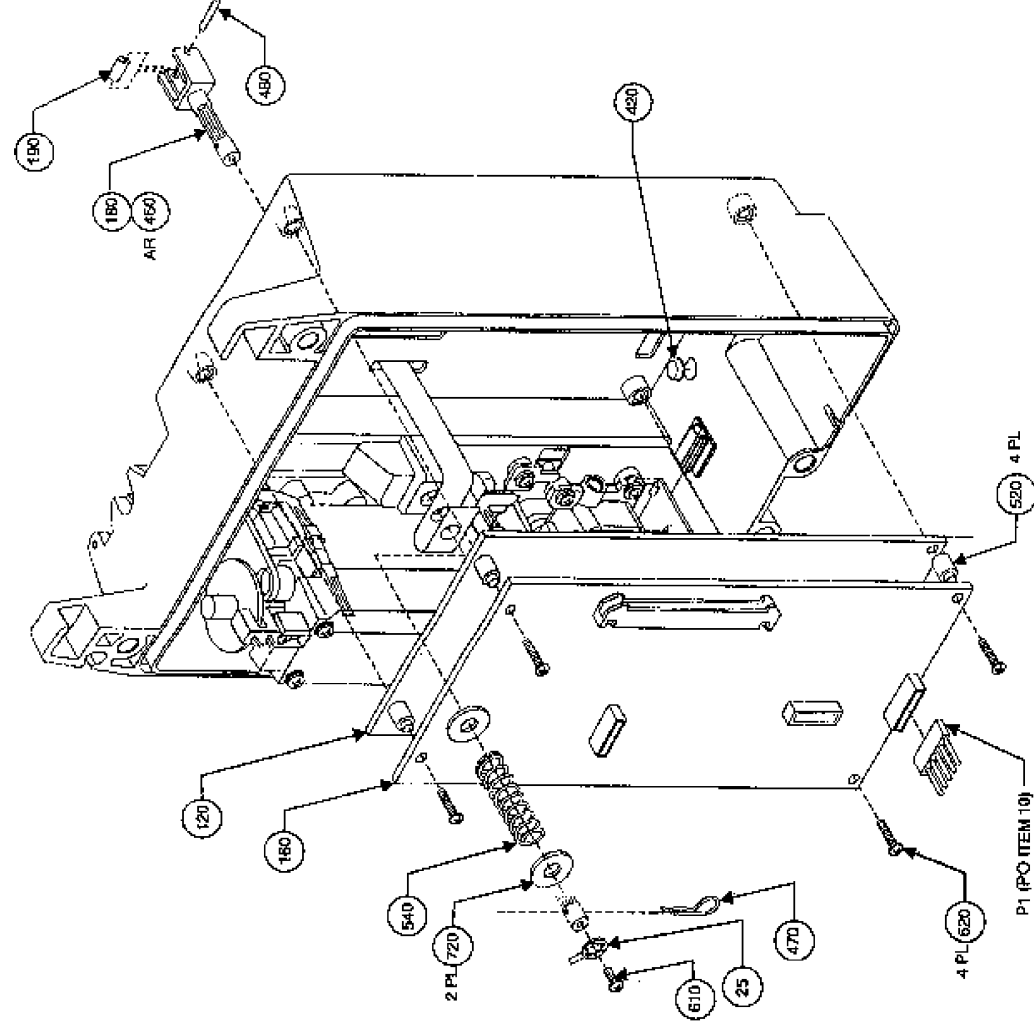

Figure 6-2b. Parts Identification Front Case Assembly

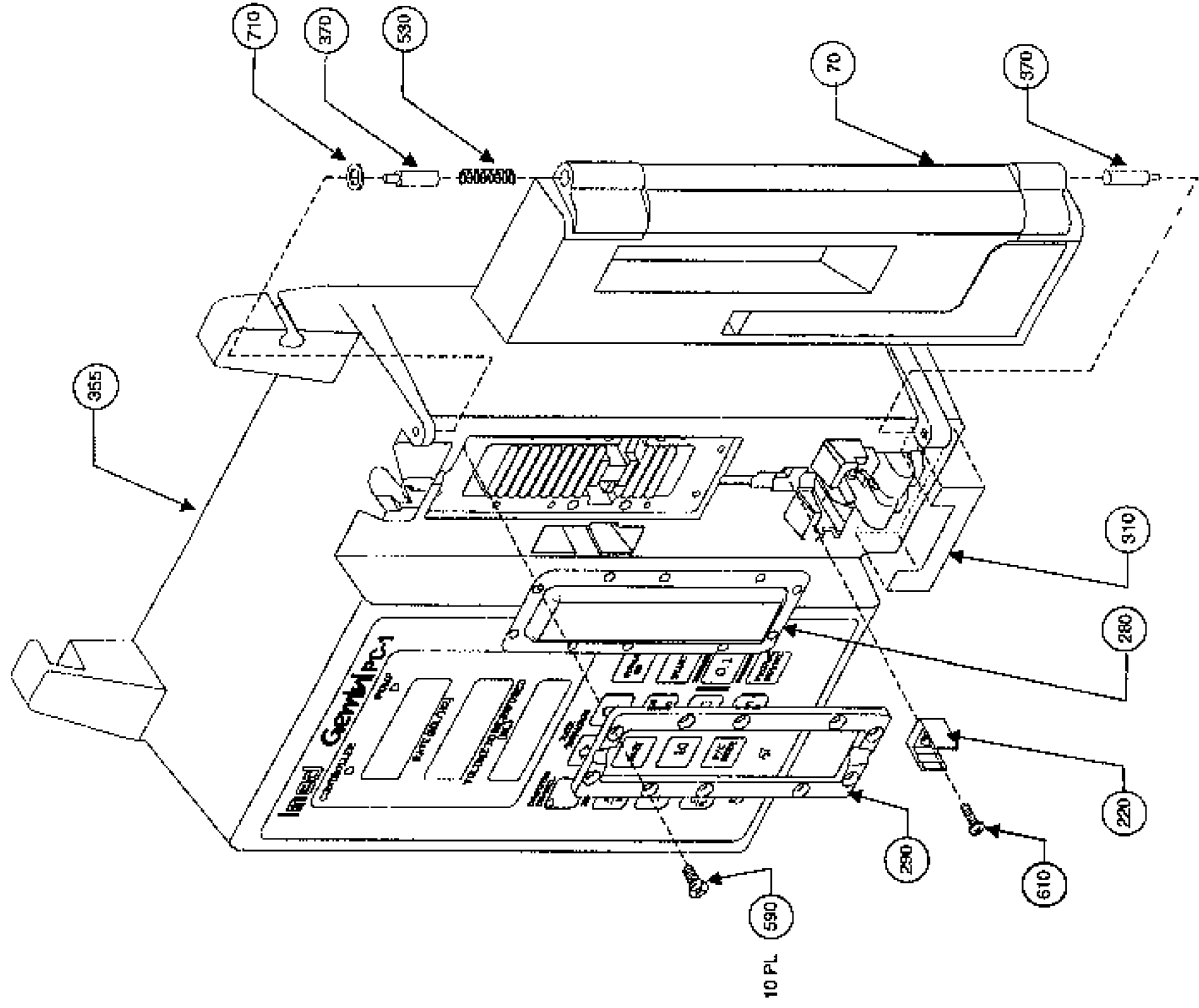

Figure 6-2c. Parts Identification Front Case Assembly

Table 6-3. Parts List - Door Assembly

Fig No/Item	Qty	Description	Part No	Reference
6-3	X	Door Assembly-Gemini	1320-1288-4	
6-3	1	Door, Right, Gemini Outer, Annealed	1320-2384-14	
6-3	1	Cam Lock Assembly, Right	1340-1039-2	
6-3	1	Pawl, Cam Lock, Flat Nosed	1320-2385-7	
6-3	1	Cam Latch Lock Spring	1320-2154-7	
6-3	1	Pin, Dowel 5/32 x .87, SST	804003	
6-3	1	Pin, Dowel 3/32 x .50 L	804105	
6-3	1	Retaining Ring, 5/32 Dia. SST. Grv/s	806214	

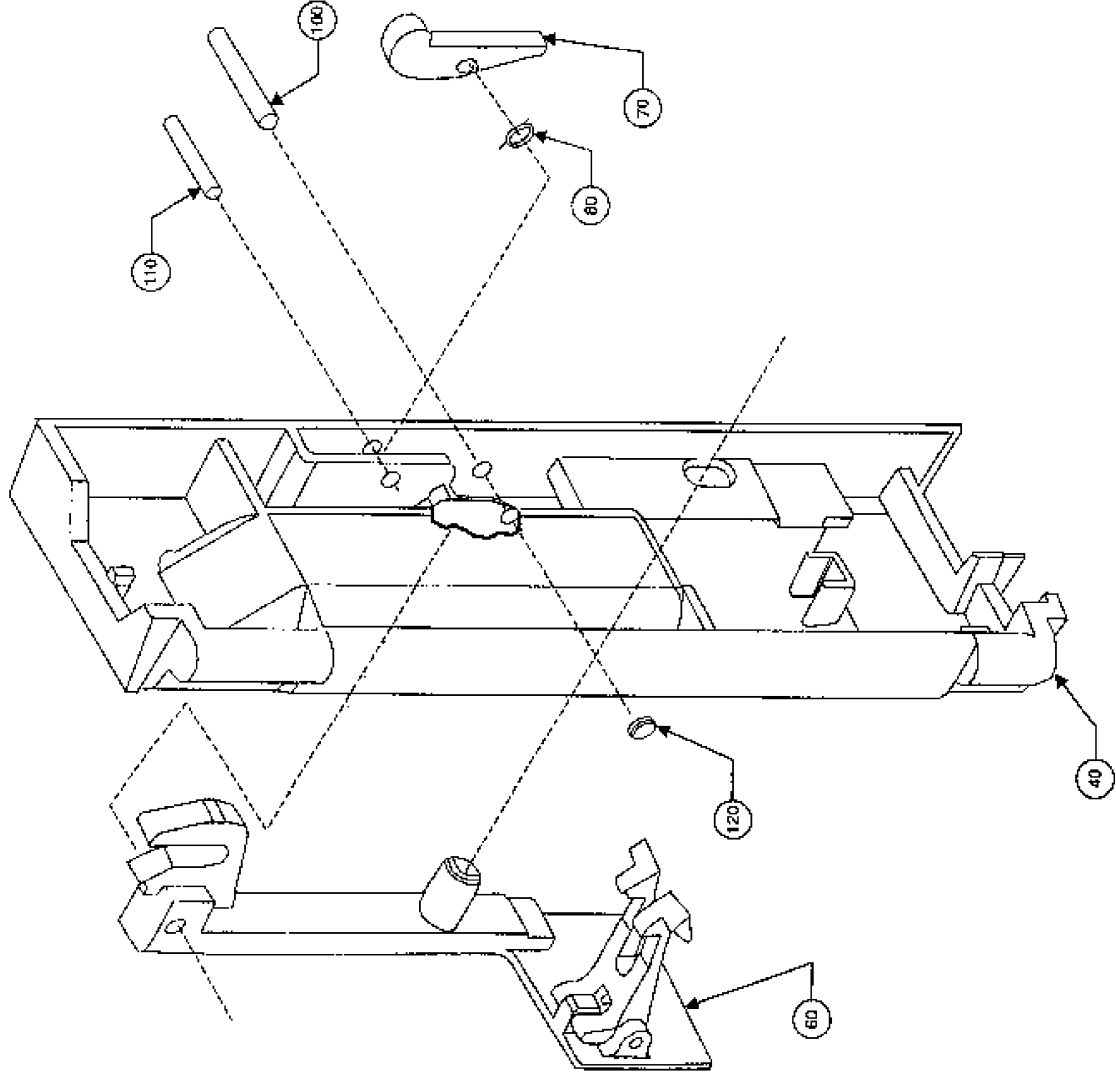

Figure 6-3. Parts Identification Door Assembly

Table 6-4. Parts List - Logic Circuit Card Assembly [v7.xx & subsequent]

Fig No/Item Ref Desig.	Qty	Description	Part No	Reference
6-2 30	X	CCA, PC-1 Logic Board	1310-7026-2	Ver 7.11
		CCA, PC-1 Logic Board	1310-7026-1	Ver 7.10
6-4 10	1	PWB, PC-1 Logic	1310-6026-7	Ver 7.xx
	X	CCA, PC-1 Logic Board (TUV)	1310-7040-2	
	X	CCA, PC-1CE Logic/Analog Board	1310-7046-1	
	1	PWB, PC-1CE Logic	1310-6043-7	Ver 8.12 Ver 8.12
Integrated Circuits				
U1	1	I.C. 74HC132 2-INP NAND	812205	
U2	1	I.C. RAM 8Kx8, 70NS	812237	
U3	1	I.C. Logic, Prgm, V7.11	1310-1156-1	Ver 7.11
		I.C. Logic, Prgm, V7.10	1310-1107-1	Ver 7.10
		I.C. Logic, Prgm, V8.11	1310-1154-4	Ver 8.11
		I.C. Logic, Prgm, V8.12	1310-1154-5	Ver 8.12
U4	1	I.C. 82050 COMM CONTROL	812184	
U5	1	I.C. EPLD 900 Prgm V 1.06	1310-1109-1	Ver 7.xx
		I.C. EPLD 900 Prgm V 1.09 (TUV)	1310-1153-2	
		I.C. EPLD 900 Prgm V 1.10	1310-1153-3	
U6	1	I.C. 74HCT573 OCTAL LATCH	812070	Ver 8.12
U7	1	I.C. 80C196 Microcontroller	812187	
U8	1	I.C. 74HC14	812114	
U9	1	I.C. TLC393 Dual Volt Comparator	812218	
U10	1	I.C. TLC27M2A, VIO, 5MV, OP-AMP	812219	
U11	1	I.C. LT1079, QUAD OP AMP	812062	
U12	1	I.C. CMOS VOLTAGE CONVERTER	812061	
U13	1	I.C. 1403 PRGN LOW VOLT REF	812022	
U14	1	I.C. 74HCC0 QUAD 2 INP CMOS NAND	812171	
U15	1	I.C. 40109 V LVL SHF	812209	
Q4, Q5	2	I.C. 2950, 5V REG	812229	
D6	1	I.C. 2.5V, LOW POWER, REF	812151	
Capacitors				
C1	1	Capacitor, 1 μ F, 20V, 10%, TANT AX	811136-105A	
C2	1	Capacitor, 10 μ F, 10V, 10%, TANT	811116-106A	
C3	1	Capacitor, 4.7 μ F, 20V, 20%, TANT AX	811137-475A	
C4,C5	2	Capacitor, 10 μ F, 10V, 10%, TANT	811116-106A	
C6	1	Capacitor, 1000pF, 50V, 10% CER X7R	811246-102	
C7	1	Capacitor, 22 μ F, 50V, 20% CER Z5U, AX	811247-224A	
C8,C9	2	Capacitor, 1000pF, 50V, 10% CER X7R	811246-102	
C10	1	Capacitor, 1 μ F, 20V, 10%, TANT AX	811136-105A	
C11	1	Capacitor, 0.1 μ F, 50V, 10% CER X7R, AX	811246-103A	
C12-C15	4	Capacitor, 1000pF, 50V, 10% CER X7R	811246-102	
C16,C17	2	Capacitor, 10 μ F, 10V, 10%, TANT	811116-106A	
C18,C19	2	Capacitor, 0.1 μ F, 50V, 20%, CER	811247-104	
C20	1	Capacitor, 1 μ F, 20V, 10%, TANT AX	811136-105A	
C21,C22	2	Capacitor, 10 μ F, 10V, 10%, TANT	811116-106A	
C23	1	Capacitor, 6.8 μ F, 10V, 10%, TANT	811116-685A	
C24	1	Capacitor, 1 μ F, 20V, 10%, TANT AX	811136-105A	
C25,C26	2	Capacitor, 0.1 μ F, 50V, 20%, CER	811247-104	

PC-1

Fig No/Item Ref Desig.	Qty	Description	Part No	Reference
C27,C28	2	Capacitor, 30pF, 50V, 15% CER COG AX	811245-300A	
C29	1	Capacitor, 1000pF, 50V, 10% CER X7R	811246-102	
C30	1	Capacitor, 0.047μF, 50V, 10% RAD	811246-473	
C31-C33	3	Capacitor, 1000pF, 50V, 10% CER X7R	811246-102	
C34	1	Capacitor, 100pF, 100V, 2%, CER, 1LS	811254-101	
C35	1	Capacitor, 1000pF, 50V, 10% CER X7R	811246-102	
C36,C37	2	Capacitor, 1μF, 20V, 10%, TANT AX	811136-105A	
C38	1	Capacitor, 1000pF, 50V, 10% CER X7R	811246-102	
C39	1	Capacitor, .22μF, 50V, 20% CER Z5U, AX	811247-224A	
C40	1	Capacitor, 10μF, 10V, 10%, TANT	811116-106A	
C41	1	Capacitor, .039μF, 50V, 10%, CER X7R	811246-393A	
C42	1	Capacitor, 10μF, 10V, 10%, TANT	811116-106A	
C43	1	Capacitor, 39μF, 10V, 10%, TANT	811116-396A	
C44	1	Capacitor, 1μF, 20V, 10%, TANT AX	811136-105A	
C45	1	Capacitor, 1000pF, 50V, 10% CER X7R	811246-102	
C46,C47	2	Capacitor, 100pF, 100V, 2%, CER, 1LS	811254-101	
Diodes				
D1,D2	2	Diode, IN5711, Schottky	813019	
D3-D5	3	Diode, IN4148, 75V Switch	813500	
D6		NOT USED		
D7	1	Diode, IN5711, Schottky	813019	
D8	1	Diode, IN4148, 75V Switch	813500	
D9	1	Diode, IN5711, Schottky	813019	
D10	1	Diode, IN4001 RECT 50V	813200	
D11,D12	2	Diode, MBR120P, Schottky	813503	
D13,D14	2	Diode, IN4148, 75V Switch	813500	
Resistors				
R1	1	Resistor, CF, 10KΩ, 1/4W, 5%	810125-103	
R2	1	Resistor, CF, 120Ω, 1/4W, 5%	810125-121	
R3	1	Resistor, CF, 1.5MΩ, 1/4W, 5%	810125-155	
R4	1	Resistor, CF, 10KΩ, 1/4W, 5%	810125-103	
R5	1	Resistor, CF, 4.7KΩ, 1/4W, 5%	810125-472	
R6	1	Resistor, CF, 2.2MΩ, 1/4W, 5%	810125-225	
R7	1	Resistor, CF, 3.3MΩ, 1/4W, 5%	810125-335	
R8	1	Resistor, CF, 1.5KΩ, 1/4W, 5%	810125-152	
R9	1	Resistor, CF, 200KΩ, 1/4W, 5%	810125-204	
R10	1	Resistor, CF, 33KΩ, 1/4W, 5%	810125-333	
R11	1	Resistor, CF, 10KΩ, 1/4W, 5%	810125-103	
R12,R13	2	Resistor, CF, 4.7KΩ, 1/4W, 5%	810125-472	
R14	1	Resistor, MF, 3.4KΩ, 1/4W, 1%, 50PPM	810229-342	
R15	1	Resistor, CF, 470KΩ, 1/4W, 5%	810125-474	
R16	1	Resistor, MF, 20KΩ, 1/4W, 1%	810229-203	
R17	1	Resistor, MF, 24.9KΩ, 1/4W, 1%	810229-2492	
R18	1	Resistor, CF, 10KΩ, 1/4W, 5%	810125-103	
R19	1	Resistor, CF, 3.9KΩ, 1/4W, 5%	810125-392	
R20	1	Resistor, MF, 2KΩ, 1/4W, 1%	810229-202	
R21	1	Resistor, MF, 15KΩ, 1/4W, 1%	810229-153	
R22	1	Resistor, CF, 1KΩ, 1/4W, 5%	810125-102	
R23	1	Resistor, CF, 12KΩ, 1/4W, 5%	810125-123	
R24,R25	2	Potentiometer, 10KΩ, 20 turn	810336-103Y	

Fig No/Item Ref Desig.	Qty	Description	Part No	Reference
R26	1	Resistor, CF, 10K Ω , 1/4W, 5%	810125-103	
R27-R29	3	Resistor, MF, 1K Ω , 1/4W, 1%	810229-102	
R30	1	Resistor, MF, 511K Ω , 1/4W, 1%	810229-5113	
R31	1	Resistor, MF, 1K Ω , 1/4W, 1%	810229-102	
R32	1	Resistor, MF, 511K Ω , 1/4W, 1%	810229-5113	
R33,R34	2	Resistor, MF, 100K Ω , 1/4W, 1%	810229-104	
R35,R36	2	Resistor, MF, 20K Ω , 1/4W, 1%	810229-203	
R37	1	Resistor, CF, 100K Ω , 1/4W, 5%	810125-104	
R38	1	Resistor, CF, 4.7K Ω , 1/4W, 5%	810125-472	
R39	1	Resistor, MF, 100K Ω , 1/4W, 1%	810229-104	
R40	1	Resistor, WW, .25 Ω , 4W, 1%	810591-R25	
R41	1	Resistor, CF, 1K Ω , 1/4W, 5%	810125-102	
R42	1	Resistor, CF, 15K Ω , 1/4W, 5%	810125-153	
R43	1	Resistor, CF, 20K Ω , 1/4W, 5%	810125-203	
R44	1	Resistor, MF, 75K Ω , 1/4W, 1%	810229-753	
R45	1	Resistor, CF, 1K Ω , 1/4W, 5%	810125-102	
R46	1	Resistor, CF, 240 Ω , 1/4W, 5%	810125-244	
R47	1	Resistor, MF, 100K Ω , 1/4W, 1%	810229-104	
R48	1	Resistor, MF, 1.47K Ω , 1/8W, 25%	810219-1471	
R49	1	Resistor, CF, 56 Ω , 1/4W, 5%	810125-560	
R50	1	Resistor, MF, 100K Ω , 1/4W, 1%	810229-104	
R51	1	Resistor, CF, 330 Ω , 1/4W, 5%	810125-331	
R52	1	Resistor, CF, 100K Ω , 1/4W, 5%	810125-104	
R53	1	Resistor, CF, 1.5K Ω , 1/4W, 5%	810125-152	
R54-R56	3	Resistor, CF, 100K Ω , 1/4W, 5%	810125-104	
R57	1	Resistor, MF, 182K Ω , 1/8W, 25%	810219-1823	
R58	1	Resistor, CF, 10 Ω , 1/4W, 5%	810125-100	
RA1	1	Resistor Array, 10K Ω , 2W, 2% SIP	810900-103J	
RA2,RA3	2	Resistor Array, 22K Ω , 2W, 2% SIP, 10 BUS	810900-223	
RA4	1	Resistor Array, 100K Ω , .2W, 2% SIP, 8 PIN	810994-104I	
RA5		NOT USED		
RA6	1	Resistor Array, 20K Ω , .2W, 2% SIP, 10 PIN	810994-203M	Ver 7.10
		Resistor Array, 20K Ω , .2W, 1% SIP, 10 BUS	810993-203M	
Transistors				
Q1	1	Transistor, FET, VN0206, 3.0 AMP, N-CH	814005	
Q2-Q5		NOT USED		
Q6	1	Transistor, FET, VN0206, 3.0 AMP, N-CH	814005	
Q7	1	Transistor, 2N4401, NPN SIL	814103	
Q8-Q11	4	Transistor, FET, VN2206, N-CH	814006	
Q12,Q13	2	Transistor, FET, VP0206N3, P-CH	814001	
Q14	1	Transistor, FET, VN0206, 3.0 AMP, N-CH	814005	
Q15-Q18	4	Transistor, FET, VN2206, N-CH	814006	
Q19	1	Transistor, FET, VP0206N3, P-CH	814001	
Connectors				
J1	1	Connector, Header, 1 x 20 Unshrouded	851069	
J2	1	Connector, Header, 5 CKT LOCK	851049	
J3	1	Connector, Header, 2 x 25	851066	
J4	1	Connector, Header, 10 CKT LOCK	851067	
J5	1	Connector, Header, 6 CKT AU LOCK	851052	
J6	1	Connector, Header, 6 CKT LOCK	851047	

PC-1

Fig No/Item Ref Desig.	Qty	Description	Part No	Reference
L101-106	6	Miscellaneous	815125	Ver 8.12
Z1	1	Ind, Bead, BLO2RN1, Ferrite	813067	Ver 8.12
Z2,3,4	3	Transorb, VA1000, 5.6 Volt	813068	Ver 8.12
Y1	1	Transorb, VA1000, 14 Volt	815061	Alt to Y1
B1	1	Crystal, 12 MHz	815023	
XU3	1	Crystal, 12 MHz	841018	
XU4	1	Battery, NICAD 4.8V	856077	
XU5	1	Socket, IC 32-pin	856052	
XU7	1	Socket, PLCC 28-pin	856066	
	1	Socket, PLCC, 44-pin	856055	
TP1-TP4	4	Socket, PLCC, 68-pin	815064	
	Ref	Test Point, YEL, .063 DIA	1310-5026	
	Ref	Schematic, Logic, Ver 7.11	1310-5038-1	
	Ref	Schematic, Logic, TUV	1310-5044-1	
	Ref	Schematic, Logic, PC-1CE		

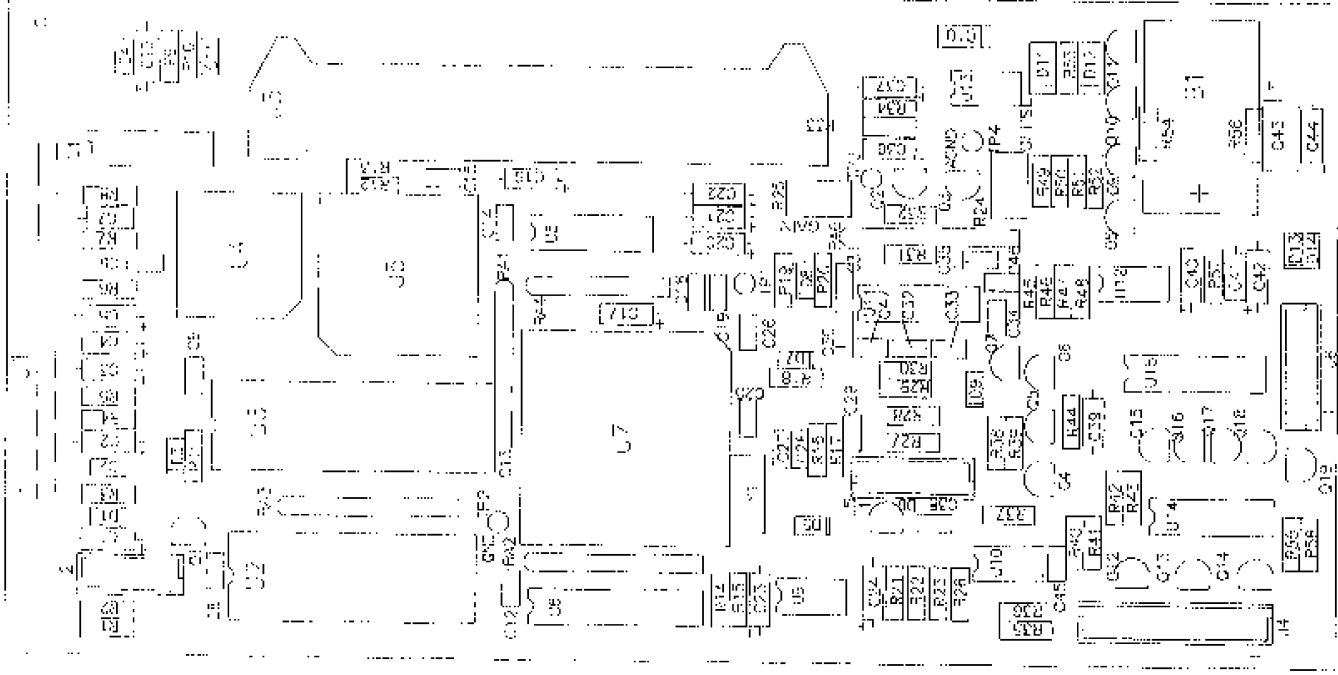

Figure 6-4. Parts Identification Logic CCA [V7.xx] PN 1310-7026-2

PC-1

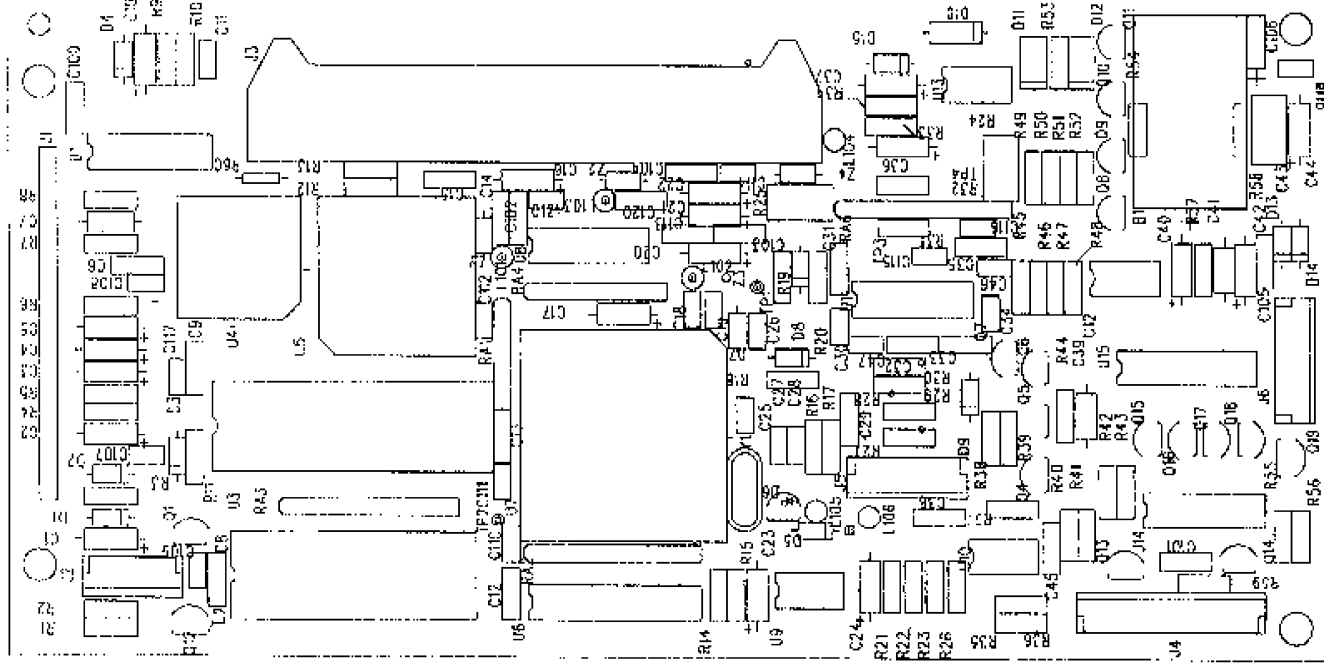

Figure 6-5. Parts Identification Logic CCA [v8.12] PN 1310-7046-1

Table 6-5. Parts List - Display Circuit Card Assembly [v7.xx & subsequent]

Fig No/Item Ref Desig.	Qty	Description	Part No	Reference
6-5	X	CCA, PC-1 Display Board	1310-7033-3	Ver 7.11
	X	CCA, PC-1 Display Board	1310-7033-1	Ver 7.10
	1	PWB, PC-1 Fract/TPN Display	1310-6013-7	
	X	CCA, PC-1T Display Board, (TUV)	1310-7041-2	Ver 8.11
	1	PWB, PC-1T Display, (TUV)	1310-6039-7	
	X	CCA, PC-1CE Display Board	1310-7044-1	Ver 8.12
	1	PWB, PC-1CE Display Board	1310-6041-7	
		Integrated Circuits		
U1	1	I.C. 74HCT4051 8 Chn Mux	812180	
U2	1	I.C. LM393 Dual Comparator	812167	
U3	1	I.C. UCN5801A Driver	812192	
U4	1	I.C. UDN2585A 8 Chn SCE Driver	812118	
U5	1	I.C. 74HCT564 Octat D Type FF	812210	
U6		NOT USED		
U7	1	I.C. 74HCT573 Latch	812070	
U8	1	I.C. 74HCT139 Decoder	812116	
U9	1	I.C. 7416 Buffer	812089	
U10	1	I.C. 74HCT32 Quad OR	812090	
U11	1	I.C. 80C31BH 8 Bit Microcontroller	812188	Ver 7.11
U12	1	I.C. Display PRGM V7.10	1310-1157-1	Ver 7.10
		I.C. Display PRGM (TUV)	1310-1110-1	Ver 8.11
		I.C. Display PRGM V8.1	1310-1155-4	Ver 8.11
U13	1	I.C. 8K x 8 CMOS 200ns	1310-1155-5	Ver 8.12
		Capacitors		
C1-C5	5	Capacitor, 1000pF, 50V, 10% CER RAD	811246-102	
C6		NOT USED		
C7-C13	7	Capacitor, 1000pF, 50V, 10% CER RAD	811246-102	
C14-C15	2	Capacitor, 15pF, 50V, 20% CER COG AX	811247-150A	
C16		NOT USED		
C17	1	Capacitor, 1000pF, 50V, 10% CER RAD	811246-102	
C18	1	Capacitor, 10µF, 10V, 10% TANT AX	811116-106A	
		Resistors		
W1	1	Resistor, CF, 0Ω, 1/4W, 5%	810125-000	
W2-W3		NOT USED		
W4	1	Resistor, CF, 0Ω, 1/4W, 5%	810125-000	
W5		NOT USED		
W6	1	Resistor, CF, 0Ω, 1/4W, 5%	810125-000	
R1	1	Resistor, CF, 0Ω, 1/4W, 5%	810125-000	
R2	1	Resistor, CF, 4.7KΩ, 1/4W, 5%	810125-472	
R3-R4	2	Resistor, MF, 2.15KΩ, 1/4W, 1%	810221-2151	
R5	1	Resistor, MF, 1.47KΩ, 1/8W, ±25%	810219-1471	
R6	1	Resistor, CF, 4.7KΩ, 1/4W, 5%	810125-472	
R7-R9	3	Resistor, CF, 1KΩ, 1/4W, 5%	810125-102	
R10	1	Resistor, CF, 10KΩ, 1/4W, 5%	810125-103	
RA1	1	Resistor Array, 39Ω, 1/4W, 2%, 16 pin	812085	
RA2-RA3	2	Resistor Array, 270Ω, .2W, 2%, 8 pin	810900-271H	

PC-1

Fig No/Item RefDesig.	Qty	Description	Part No	Reference
RA4	1	Resistor Array, 1K Ω , 1/4W, 2%, 16pin	812201	
RA5	1	Resistor Array, 10K Ω , .2W, 2%, 10 pin	810900-103	
DS1-DS2	2	LED, 4mm flat Top, Green	813305	
DS3-DS10	8	Display, 7-Seg., LED, Green, .3" high	815040	
DS11	1	Display, 8-Char, Smart 5 x 7 Dot Matrix	815057	
DS12	1	Display, A/N Programmable, 8 char, yel	815063	
DS13	1	LED, Light Bar, Green, 16 pin .35 x .75	815041	Ver 7.10
DS14-DS17	1	LED, Light Bar, Green, 8 pin .75 x .15	815038	
	4	LED, T-1 PKG, Green	813015	
Miscellaneous				
CR1	1	Transient V Suppressor, 5V, Unipol	813024	
Y1	1	Crystal 12 MHz	815023	
J1	1	Connector, 1 x 20, socket, vert PC	856069	
J2	2	Connector, 1 x 10, HDR Unshr Rt Angle	851061	
XU12	1	Socket, DIP, 28 pin, Flush Mount	856067	
XDS11	2	Spacer, 16-pin DIP .06	805036	
	2	Spacer, one piece, GEMINI	1320-3066-7	Ver 7.10
	6	Spacer, T1-LED MTG single	809077	Ver 7.10
	1	Bumper Adh Backed .23 High	809094	
AR	AR	Sealant Adh RTV 162 Wht Paste	832020	
AR	AR	Tape Mylar, Yellow	830000	
Ref	Ref	Schematic, Display Board PC-1T V7.xx	1310-5033	
Ref	Ref	Schematic, Display Board, TUV	1310-5039-1	
Ref	Ref	Schematic, Display Board, PC-1CE	1310-6041-7	

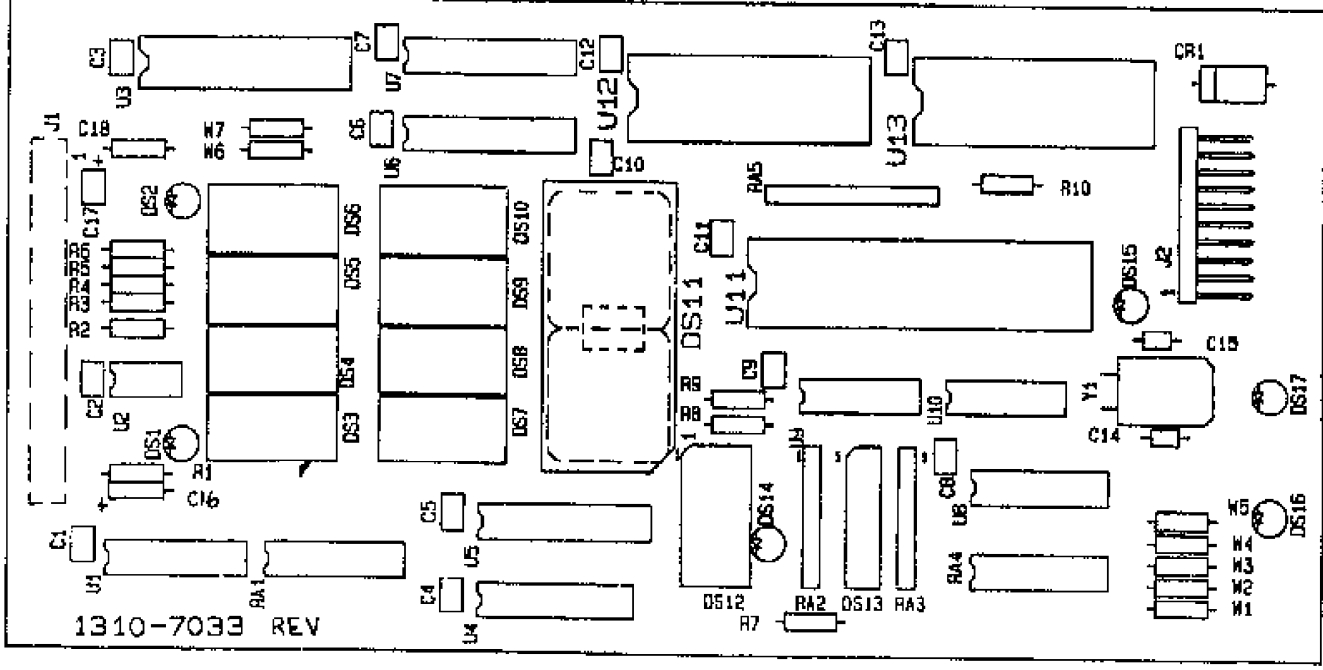

Figure 6-6. Parts Identification Display Circuit Card Assembly [v7.xx] PN 1310-7033-3

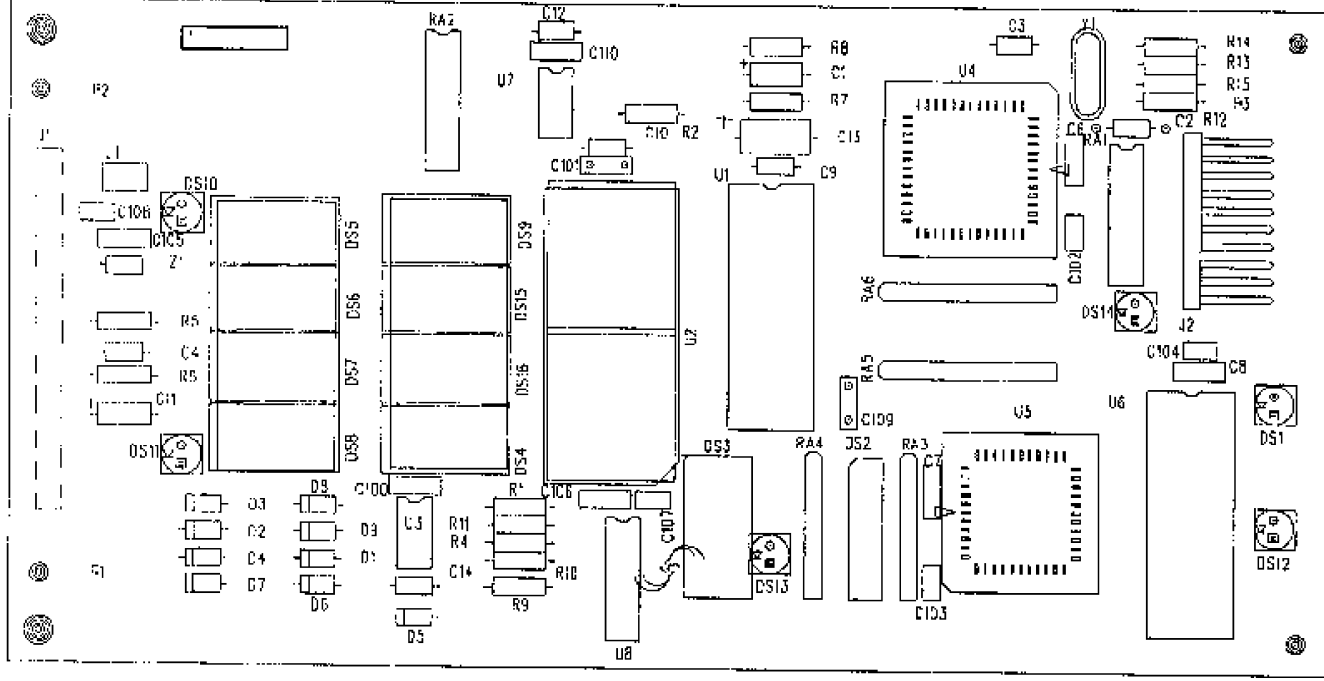

Figure 6-7. Parts Identification Display Circuit Assembly [v8.12] PN 1310-7044-1

Table 6-6. Parts List - Rear Case Assembly

Fig No/Item	Qty	Description	Part No	Reference
6-1a 35	X	Rear Case Assembly (V7.xx)	1310-1114-1	Alt to Item 35
6-1a 37	X	Rear Case w/Acme Pole Clmp Asmblly(220V)	1310-1160-1	
6-6 10	1	CCA, Power Supply	1310-7036-5	Alt To Item 10
6-6 20	1	CCA, Power Supply w/crowbar	1310-7036-3	
6-6 30	1	Transformer Harness Assembly	1310-1013-1	Alt To Item 370
6-6 40	1	AC Receptacle Assembly .5A Fuse	1320-1079-4	
6-6 50	1	Pole Clamp Assembly w/rear case	1310-1097-1	
6-6 60	1	Harness Assembly, PC-IT Audio/Switch	1310-1108-2	
6-6 100	1	Harness, Audio	1320-1209-1	Alt To Item 370
6-6 110	1	Knob Round Shaft Pole Clamp	1310-2021-7	
6-6 120	1	Label, Pole Clamp	350-2087-7	Alt To Item 370
6-6 130	1	Gasket, Seal AC Receptacle	1310-2102-7	
6-6 140	2	Gasket, Comm Board, PC-1	1310-2103-7	Alt To Item 370
6-6 150	1	Spring, A/C Locking	1310-2004-7	
6-6 160	1	Lock Washer, Intl, A/B, 3/8, cs, galv	803216	Alt To Item 370
6-6 170	1	Lock Washer, Intl, A/B, 10, c stl, galv	803204	
6-6 180	1	Washer, Shoulder #4 nylon	803612	Alt To Item 370
6-6 190	1	Washer, Flat, 3/8, steel, nkl	803017	
6-6 200	1	Nut, 3/8-32, Dress	802007	Alt To Item 370
6-6 210	1	Screw, Machine, 10-32X.25, xrec, pnh	801032	
6-6 220	2	Lock Washer, 5/16, carbon stel, galv	803210	Alt To Item 370
6-6 230	2	Washer, #6, sst	803021	
6-6 240	AR	Screw, Machine, 4-40X.50, xrec, pnh	801004	Alt To Item 370
6-6 250	4	Tubing, Heatshrink, 1/4" blk genl prp	834004	
6-6 260	1	Lock Washer, Intl, A/B, 6, c stl, galv	803201	Alt To Item 370
6-6 270	4	Screw, Machine, 5/16-18X.50, sltd, pnh	801019	
6-6 280	7	Screw, Machine, 6-32X1.0, xrec, pnh	801037	Alt To Item 370
6-6 290	1	Screw, Machine, 4-40X.25, xrec, pnh	801002	
6-6 340	AR	Heatsink, Insulated Pwr Semiconductor TO-226	847034	Alt To Item 370
6-6 350	AR	Sealant, Adhesive RTV 162 wht pasted	832020	
6-6 360	AR	Tie Cord, PVC .020-.080 Dia	834000	Alt To Item 370
6-6 370	AR	Cable Tie 4" Auto Feed	834031	
6-6 360	AR	Loctite, 242, Rem, threadlocking	832008	Alt To Item 370
6-6 370	1	Label, Mains (English & Australia) (220V)	960-2152-7	
6-6 370	1	Label, Mains (German) (220V)	960-2174-7	Alt To Item 370
6-6 370	1	Label, Mains (French) (220V)	960-2178-7	
6-6 370	1	Label, Mains (Swedish) (220V)	960-2177-7	Alt To Item 370
6-6 370	1	Label, Mains (Spanish) (220V)	960-2183-7	
6-6 370	1	Label, Mains (Italian) (220V)	960-2179-7	Alt To Item 370
6-6 370	1	Label, Mains (English & Australia) (220V)	960-2152-7	

Table 6-7. Parts List - Power Supply Circuit Card Assembly for [v7.xx & subsequent]

Fig No/Item Ref Desig.	Qty	Description	Part No	Reference
	X	CCA PC-1 Power Supply Board CCA PC-1 Power Supply Board PWB PWR/Dual State Charge CCA PC-1 Power Supply Board CCA PC-1 Power Supply Board, CE PWB PWR/Dual State Charger	1310-7036-1 1310-7032-1 1310-6030-7 1310-7036-6 1310-7036-7 1310-6036-7	Ver 7.10 Ver 7.10 Ver 7.11 Ver 8.xx
	1			
		Integrated Circuits		
U1	1	I.C. UC 2524A Regulating Pulse	812168	
U2	1	I.C. TLC393, Dual Volt Comparator	812218	
U3	1	I.C. TLC 27M2A, VIO, 5mV, OP-AMP	812219	
U4	1	I.C. CMOS RS-232/CCITT V.28	812146	
U5	1	I.C. LM5578 Switching Regulator	812191	
U6	1	I.C. TLC 27M2A, VIO, 5mV, OP-AMP	812219	
U7	1	I.C. TLC393, Dual Volt Comparator	812218	
U8	1	I.C. LM358 Dual Op Amp	812042	
U9	1	I.C. CMOS Voltage Converter	812061	
U10	1	I.C. TLC393, Dual Volt Comparator	812218	
Q2,Q6	2	I.C. TL451 Programmable PRCN	812190	
CR10,CR24, CR25	3	I.C. LM385-2.5, 1.5% Voltage Ref	812234	
		Capacitors		
C1	1	Capacitor, 0.1µF, 50V, 10%, CER RDL	811246-104-1	
C2	1	Capacitor, 1000µF, 63V 20% AL ELCTLT	811397-108	
C3	1	Capacitor, 0.01µF, 50V, 10% CER AX X7R	811246-103A	
C4	1	Capacitor, 0.1µF, 50V, 10%, CER RDL	811246-104-1	
C5	1	Capacitor, 4.7µF, SOL TANTALUM AXIAL	811137-475A	
C6	1	Capacitor, AL ELCTLT RADIAL PC MT	811317-337	
C7	1	Capacitor, 6.8µF, SOL TANTALUM AXIAL	811116-685A	
C8	1	Capacitor, 0.01µF, 50V, 10% CER AX X7R	811246-103A	
C9	1	Capacitor, 0.1µF, 50V, 10%, CER RDL	811246-104-1	
C10	1	Capacitor, AL ELCTLT RADIAL PC MT	811317-108	
C11	1	Capacitor, 10pF, 100V, CER AXIAL COG	811256-100A	
C12	1	Capacitor, 820pF, 100V, CER AXIAL X7R	811256-821A	
C13	1	Capacitor, AL ELCTLT RADIAL PC MT	811397-227	
C14	1	Capacitor, 0.1µF, 50V, 10%, CER RDL	811246-104-1	
C15,C16	2	Capacitor, 10pF, 100V, CER AXIAL COG	811256-100A	
C17,C18	2	Capacitor, 0.1µF, 50V, 10%, CER RDL	811246-104-1	
C19	1	Capacitor, AL ELCTLT RADIAL PC MT	811397-227	
C20	1	Capacitor, 0.022µF, 200VDC, ±10%, CER DIP	811246-223	
C21	1	Capacitor, 0.01µF, 50V, 10% CER AX X7R	811246-103A	
C22-C24	3	Capacitor, 0.001µF, CER AXIAL COG X7R	811247-102A	
C25	1	Capacitor, 0.1µF, 50V, 10%, CER RDL	811246-104-1	
C26	1	Capacitor, 10µF, SOL TANTALUM AXIAL	811116-106A	
C27,C28	2	Capacitor, 1µF, 20V, SOL TANT AXIAL	811136-105A	
C29	1	Capacitor, 0.1µF, 50V, 20% CER AX Z5U	811247-104A	
C30	1	Capacitor, 10µF, SOL TANTALUM AXIAL	811116-106A	
C31	1	Capacitor, 0.1µF, 50V, 20% CER AX Z5U	811247-104A	
C32	1	Capacitor, 0.022µF, 200VDC, ±10%, CER DIP	811246-223	

PC-1

Fig No/Item Ref Desig.	Qty	Description	Part No	Reference
C33	1	Capacitor, 30pF, 50V, 15%, CER AX COG	811245-300A	
C34	1	Capacitor, 0.001 μ F, GER AXIAL COG X7R	811247-102A	
C35	1	Capacitor, 100pF, 50V, 10% CER AXCOG	811246-101A	
C36	1	Capacitor, 0.1 μ F, 50V, 20% CER AX Z5U	811247-104A	
C37	1	Capacitor, 100pF, 50V, 10% CER AXCOG	811246-101A	
C38	1	Capacitor, 0.1 μ F, 50V, 10%, CER RDL	811246-104-1	
C39	1	Capacitor, 0.001 μ F, CER AXIAL COG X7R	811247-102A	
C40	1	Capacitor, 1 μ F, 20V, SOL TANT AXIAL	811136-105A	
C41,C42	1	Capacitor, 0.1 μ F, 50V, 10%, CER RDL	811246-104-1	
C43,C44	1	Capacitor, 10 μ F, SOL TANTALUM AXIAL	811116-106A	
C45	1	Capacitor, 0.1 μ F, 50V, 10%, CER RDL	811246-104-1	
C46		NOT USED		
C47,C48	1	Capacitor, 10 μ F, SOL TANTALUM AXIAL	811116-106A	Ver 7.11 only
C51	1	Capacitor, Cer, 100V, 10%, 3300PF, AX	811256-332A	
CR1-CR4	4	Diodes Diode, MBR1060 10A	813203	
CR5		NOT USED		
CR6	1	Diode, Silicone Switching 75V	813500	
CR7,CR8	2	Diode, Zener 7.5V 1W	813023	
CR9	1	Diode, MBR2060 20A (See I.C. Listing)	813204	
CR10		NOT USED		
CR11		NOT USED		
CR12	1	Diode, Silicone Switching 75V	813500	
CR13-CR15	3	Diode, 1N5819 Schottky	813505	
CR16	1	Diode, Zener 7.5V 1W	813023	
CR17,CR18	2	Diode, 1N5711 Schottky	813019	
CR19	1	Diode, Transient V Suppressor 5V	813024	
CR20,CR23	1	Diode, MBR120P Schottky Bar Rect	813503	Ver 7.10
CR20	1	Diode, 1n5711 Schottky	813019	
CR21	1	Diode, Silicone Switching 75V	813500	
CR22	1	Diode, 1N5711 Schottky	813019	
CR22,CR23	1	Diode, 1N5711 Schottky (See I.C. Listing)	813019	Ver 7.10
CR24,CR25				
R1	1	Resistors Resistor, 5.1K Ω 1/2W 5% CFR	810135-512	
R2	1	Resistor, 1K Ω 1/4W 5% CFR	810125-102	
R3	1	Resistor, 768K Ω 1/4W \pm 1% MF	810229-7683	
R4	1	Resistor, 61.9K Ω 1/4W \pm 1% MF	810229-6192	
R5	1	Resistor, 27.4K Ω 1/4W \pm 1% MF	810229-2742	
R6	1	Resistor, 47 Ω 1/4W 5% CFR	810125-470	
R7	1	Resistor, 10K Ω 1/4W 1% MF	810229-103	
R8	1	Resistor, 0.05 3W 1% WW	810563-R05	
R9	1	Resistor, 4.7K Ω 1/4W 5% CFR	810125-472	
R10	1	Resistor, 10K Ω 1/4W 1% MF	810229-103	
R11	1	Resistor, 47K Ω 1/4W 5% CFR	810125-473	
R12	1	Resistor, 4.7K Ω 1/4W 5% CFR	810125-472	
R13	1	Resistor, 43.2K Ω 1/4W \pm 1% MF	810229-4322	
R14	1	Resistor, 20K Ω 1/8W .25% MF	810219-203	
R15	1	Resistor, 20K Ω 1/4W \pm 1% MF	810229-203	Ver 7.10
R16,R17	2	Resistor, 30.1K Ω 1/4W \pm 1% MF	810229-3012	
R18	1	Resistor, 100K Ω 1/4W .1% MF	810229-104	
	1	Resistor, 110K Ω 1/4W \pm 1% MF	810229-114	

Fig No/Item Ref Desig.	Qty	Description	Part No	Reference
R19	1	Resistor, 20K Ω 1/4W 5% CFR	810125-203	
R20	1	Resistor, 10K Ω 1/4W 1% MF	810229-103	
R21	1	Resistor, 240K Ω 1/4W 5% CFR	810125-244	
R22	1	Resistor, 10K Ω Pot Cermet 20 Turn	810336-103Y	
R23	1	Resistor, 0.05 3W 1% WW	810563-R05	
R24	1	Resistor, 200 Ω 1/4W \pm 1% MF	810229-201	
R25	1	Resistor, 10K Ω 1/4W 1% MF	810229-103	
R26	1	Resistor, 47K Ω 1/4W 5% CFR	810125-473	
R27,R28	2	Resistor, 130K Ω 1/4W \pm 1% MF	810229-134	
R29	1	Resistor, 182K Ω 1/8W 25% MF	810219-1823	
R30	1	Resistor, 6.8K Ω 1/4W 5% CFR	810125-682	
R31	1	Resistor, 10K Ω 1/4W 1% MF	810229-103	
R32	1	Resistor, 0.1 Ω 4W 1% WW	810591-0R1	
R33	1	Resistor, 47K Ω 1/4W 5% CFR	810125-473	
R34	1	Resistor, 100K Ω 1/4W 1% MF	810229-104	
R35	1	Resistor, 51K Ω 1/4W 5% CFR	810125-513	
R36	1	Resistor, 47K Ω 1/4W 5% CFR	810125-473	
R37	1	Resistor, 15K Ω 1/4W 5% CFR	810125-153	
R38	1	Resistor, 2.2M Ω 1/4W 5% CFR	810125-225	
R39	1	Resistor, 6.2K Ω 1/4W 5% CFR	810125-622	
R40	1	Resistor, 100K Ω 1/4W 1% MF	810229-104	
R41	1	Resistor, 10K Ω 1/4W 1% MF	810229-103	
R42	1	Resistor, 300K Ω 1/4W 5% CFR	810125-304	
R43-R45	3	Resistor, 100K Ω 1/4W 1% MF	810229-104	
R46	1	Resistor 20K Ω 1/4W 5% CFR	810125-203	
R47	1	Resistor 1K Ω 1/4W 5% CFR	810125-102	
R48	1	Resistor, 10K Ω 1/4W 1% MF	810229-103	
R49,R50	2	Resistor, 100K Ω 1/4W 1% MF	810229-104	
R51		NOT USED		
R52	1	Resistor, 15K Ω 1/4W 5% CFR	810125-153	
R53	1	Resistor, 5.1K Ω 1/2W 5% CFR	810135-512	
R54	1	Resistor, 47K Ω 1/4W 5% CFR	810125-473	
R55	1	Resistor, 6.2M Ω 1/4W 5% CFR	810125-625	
R56	1	Resistor, 10K Ω 1/4W \pm 1% MF	810229-103	
R57	1	Resistor, 47K Ω 1/4W 5% CFR	810125-473	
R58,R59		NOT USED		
R60	1	Resistor, 357K Ω 1/4W 1% MF 50PPM	810223-3573	
R61	1	Resistor, 47K Ω 1/4W 5% CFR	810125-473	
R62	1	Resistor, 6.2M Ω 1/4W 5% CFR	810125-625	
R63	1	Resistor, 100K Ω 1/4W 1% MF	810229-104	
R64	1	Resistor, 4.7K Ω 1/4W 5% CFR	810125-472	
R65	1	Resistor, 100K Ω 1/4W 5% MF	810229-104	
R66	1	Resistor, 10K Ω 1/4W 1% MF	810229-103	
R67	1	Resistor, 120 Ω 1/4W 5% CFR	810125-121	
R68	1	Resistor, 100 Ω 1/4W 5% CFR	810125-101	
R69,R78	1	Resistor, 1K Ω 1/4W 5% CFR	810125-102	V 7, 10 R69 only
Transistors				
Q1	1	Transistor, NPN BJT 60V 10mA	814110	
Q2		(See I.C. Listing)		
Q3	1	Transistor, PNP BJT 60V 10mA	814111	
Q4	1	Transistor, Darlington MPS A13	814301	
Q5	1	Transistor, 2N4403 PNP Silicon Genl	814104	
Q6		(See I. C. Listing)		
Q7	1	Transistor, FET P-CH ENHNCEMENT PWR	814109	

PC-1

Fig No/Item Ref Desig.	Qty	Description	Part No	Reference
Q8		NOT USED	814103	
Q9	1	Transistor, 2N4401 NPN Silicon Genl	814103	Ver 7.10
Q10		NOT USED		
Q11	1	Transistor, 2N4401 NPN Silicon Genl	814112	
Q12	1	Transistor, MPS6614, NPN	814103-1	
		Transistor, MPS6513	814103	
Q13,Q14	2	Transistor, 2N4401 NPN Silicon Genl	814109	
Q15	1	Transistor, FET P-CH ENHANCEMENT PWR	814004	
Q16	1	Transistor, FET P-CH 1.6 AMP	814003	
Q17	1	Transistor, FET N-CH 2.4 AMP	814103	
Q18	1	Transistor, 2N4401 NPN Silicon Genl	814006	
Q19	1	Transistor, FET N-CH VN2206	814005	
Q20	1	Transistor, FET N-CH 3.0 AMP VN0206	814001	
Q21	1	Transistor, FET P-CH VP0206N3	814900	
Q22	1	SCR MCR68, 100V 12A	814001	
Q23	1	Transistor, FET P-CH VP0206N3		
		Connectors		
J1	1	Connector, HDR 2 x 25 Latching Str.	851062	
J2	1	Connector, 10A LKG PLZD HDR/HSG/CRP	851051	
J3	1	Connector, D-SubMIN PCB MT 9-SKT MET	856061	Ver 7.11
J4	1	Connector, 6 pin FEM DIN PC MT	856075	Alt. to J4
J5	1	Connector, 6 pin FEM DIN PC MT	856076	
J6	1	Connector, 10A LKG PLZD HDR/HSG/CRP	851051	
J7	1	Connector, 0.1" Spaced CRP-TO-W	851044	
		Connector, HDR RT ANGLE 3 CKT	851077	
		Miscellaneous		
F1	1	Fuse, Pico PC MT 5A, 125V	842001	Ver 7.10
L1	1	Fuse, Autofuse Fast Acting 5A	842002	
L2	1	Inductor, Toroid	1310-3007-7	
		Inductor, 56 MHz Q=23 Axial	815049	alt. to L2
L3	1	Inductor, 56 MHz 10% 150 Axial	815059	
TP1-TP7	1	Inductor, 250UH Toroid	1320-3080-7	
T1	8	Test Point, YEL, .063 dia	815064	Ver 7.10
RA1	7	Test Point, YEL, .063 dia	815064	
RA2	1	Transformer, PWR INV #12V	847069	Ver 7.10
XF1	1	Resistor Array, SIP 10 4.7K Ω 0.2W 2%	810900-472M	
		Resistor Array, SIP 10 10K Ω 0.2W 2%	810994-103M	
		Socket, Autofuse	856082	Ver 7.10
JPR1	2	Heatsink, PCB MT, TO-220 PKG	847088	Alt to 847088
		Heatsink, PCB MT, TO-220 PKG	847015	
		Test Pt PCB MT	815032	Alt to 815032
		Wire Discrete HKP 30 AWG WHT	820051	
		JKSCR/JKSKT Associated Hardware Kit	809083	
	2	Scr, Jack 4-40 x .50, 3/16 Hex	809090	Alt to 809083
	2	Wshr, Fl, 4, Carbon Stil, Galv	803000	Alt to 809083
	2	Nut, 4-40, Hex Mach, Scr, Carbon	802003	Alt to 809083
	2	Lk Wash, Spr, Spt, 4, Stil	803203	Alt to 809083
	3	Cable Tie, 4, Loose Pack	834047	
		Glue Hot Melt 3M3748 Elec Gr	832001	
	1	Bumper, Rubber	809002	Ver 8.12
	1	Gasket, Comm, PC-1	1310-2147-7	
	Ref	Schematic, PC-1T PWR Supply w/crowbar(Timer)	1310-5036-3	
	Ref	Schematic, PC-1T PWR Supply	1310-5032	Ver 7.10
	Ref	Schematic, PC-1 CE Pwr Supply w/crowbar (Timer)	1310-5036-4	Ver 8.12

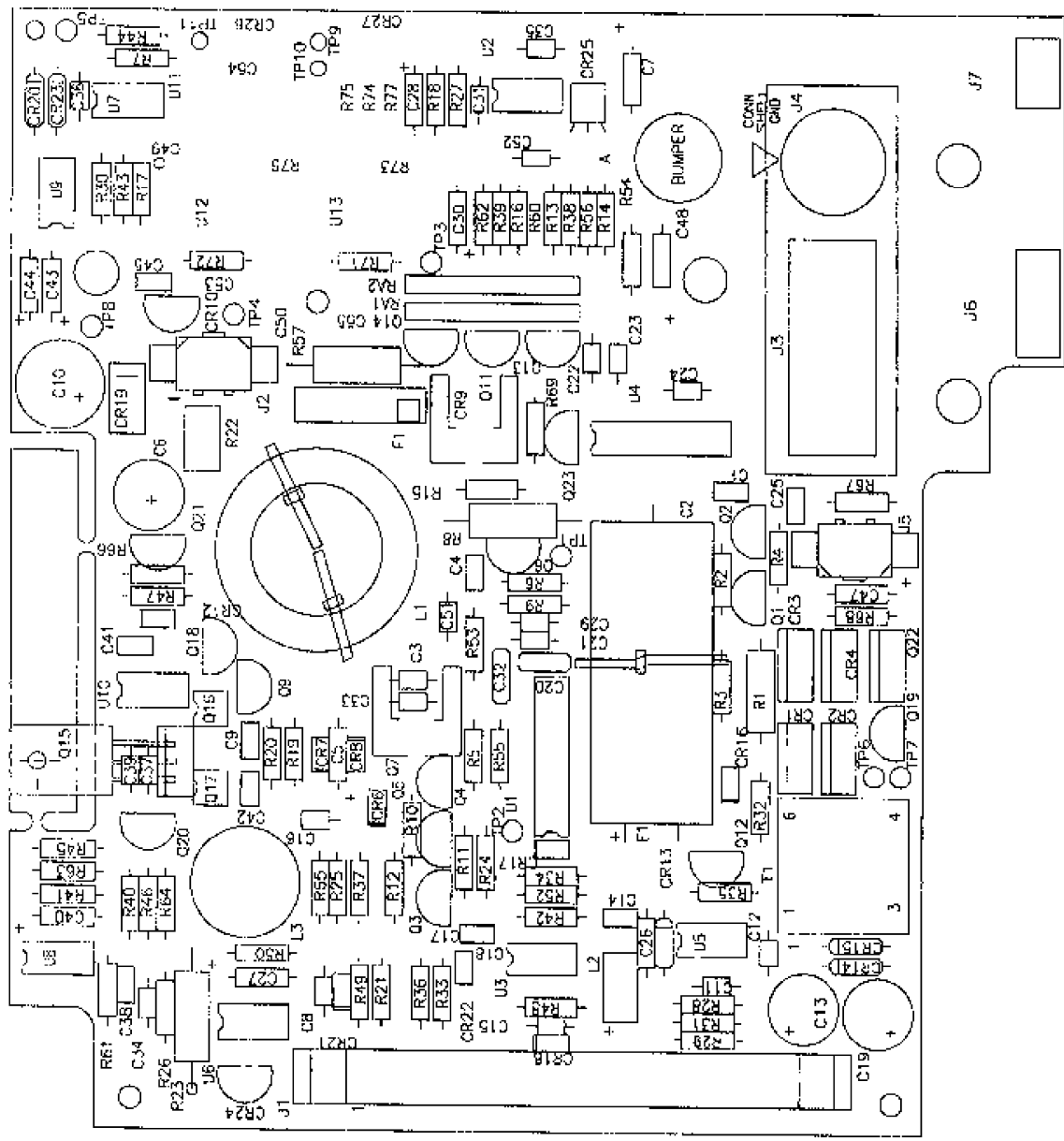

Figure 6-9. Parts Identification Power Supply CCA [v7.xx] PN 1310-5036-3

PC-1

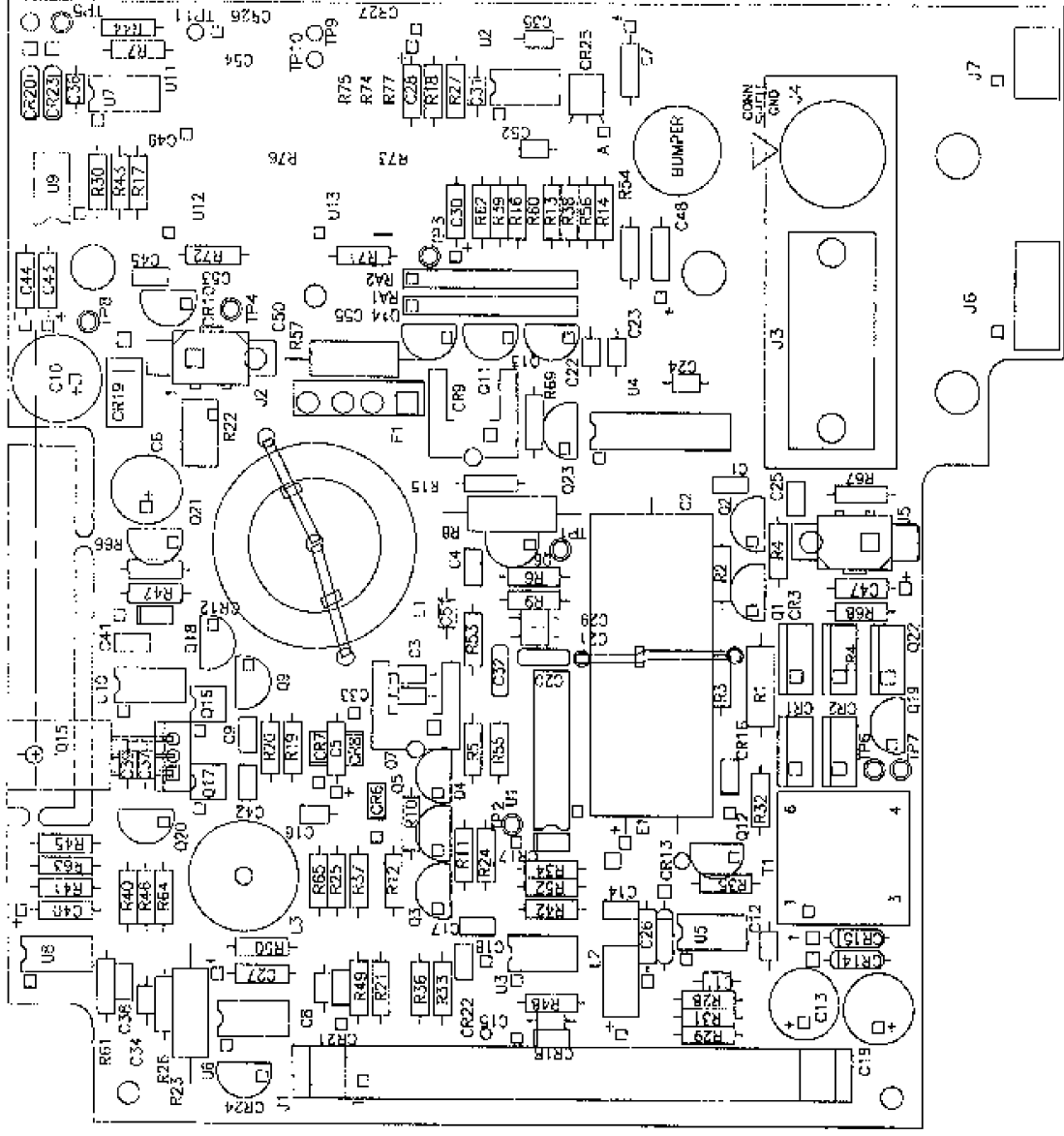

Figure 6-10. Parts Identification Power Supply CCA [v8.12] PN 1310-7036-7

WARRANTY

ALARIS Medical Systems, Inc. (hereinafter referred to as "ALARIS Medical") warrants that:

- A. Each new IMED GEMINI PC-1 volumetric Infusion Pump/Controller, excluding the battery, is free from defects in material and workmanship under normal use and service for a period of one (1) year from the date of delivery by ALARIS Medical to the original purchaser.
- b. The battery and each new accessory are free from defects in material and workmanship under normal use and service for a period of ninety (90) days from the date of delivery by ALARIS Medical to the original purchaser.

If any product requires service during the applicable warranty period, the purchaser should communicate directly with ALARIS Medical headquarters (San Diego, CA) to determine the appropriate repair facility. Except as provided otherwise in this warranty, repair or replacement will be carried out at expense. The product requiring service should be returned promptly, properly packaged and postage prepaid by purchaser. Loss or damage in return shipment to the repair facility shall be at purchaser's risk.

In no event shall ALARIS Medical be liable for any incidental, indirect or consequential damages in connection with the purchase or use of any ALARIS Medical product. This warranty shall apply solely to the original purchaser. This warranty shall not apply to any subsequent owner or holder of the product. Furthermore, this warranty shall not apply to, and ALARIS Medical shall not be responsible for, any loss or damage arising in connection with the purchase or use of any ALARIS Medical product which has been:

- (a) repaired by anyone other than an authorized ALARIS Medical service representative;
- (b) altered in any way so as to affect, in ALARIS Medical's judgement, the products stability or reliability;
- (c) subjected to misuse or negligence or accident, or which has had the product's serial or lot number altered, effaced or removed; or
- (d) improperly maintained or used in any manner other than in accordance with the written instructions furnished by a ALARIS Medical.

This warranty is in lieu of all other warranties, express or implied, and of all other obligations or liabilities of ALARIS Medical, and ALARIS Medical does not give or grant, directly or indirectly, the authority to any representative or other person to assume on behalf of ALARIS Medical any other liability in connection with the sale or use of ALARIS Medical products.

ALARIS MEDICAL DISCLAIMS ALL OTHER WARRANTIES, EXPRESS OR IMPLIED, INCLUDING ANY WARRANTY OR MERCHANTABILITY OR OF FITNESS FOR A PARTICULAR PURPOSE OR APPLICATION.

See packing inserts for international warranty, if applicable.

PC-1

NOTES

INTERNATIONAL OFFICES

If information is not available from the representative from whom you purchased this product, write or call the office nearest you.

ALARIS Medical Systems, Inc.
10221 Wateridge Circle
San Diego, CA 92121
Telephone: 619-458-7000
Facsimile: 619-458-7760

ALARIS Medical United Kingdom, Ltd.
Unit 13 Intec 2
Wade Road
Basingstoke
Hampshire, RG24 8NE
Telephone: (44) 1256 474455
Facsimile: (44) 1256 330860

ALARIS Medical Australia, Ltd.
Unit 8, 167 Prospect Hwy.
Seven Hills, N.S.W. 2147
P.O. Box 355
AUSTRALIA
Telephone: 61-2-838-0255
Facsimile: 61-2-674-4444

ALARIS Medical Canada, Ltd.
6675 Millcreek Drive, Unit 4
Mississauga, Ontario
L5N 5M4 CANADA
Telephone: 905-821-2212
Facsimile: 905-821-0886

