



Platform ANY

System Specifications for Single-Node G4 Platforms

NX-3155G-G4/NX-3175-G4/NX-8150-G4

May 12, 2021

Contents

Visio Stencils.....	iii
1. Nutanix Hardware Naming Convention.....	4
2. System Specifications.....	8
Node Naming (NX-3155G-G4).....	8
NX-3155G-G4 System Specifications.....	12
Node Naming (NX-3175-G4).....	18
NX-3175-G4 Series System Specifications.....	20
Node Naming (NX-8150-G4).....	25
NX-8150-G4 System Specifications.....	27
3. Component Specifications.....	33
LEDs and Controls for 2U1N Platforms.....	33
LED Meanings for Network Cards.....	34
Regulatory Models.....	35
Power Supply Unit (PSU) Redundancy and Node Configuration (G4 Platforms).....	36
Nutanix DMI Information.....	37
Block Connection in a Customer Environment.....	39
Connecting the Nutanix Block.....	39
4. Memory Configurations.....	41
Supported Memory Configurations (G4 Platforms).....	41
DIMM and CPU Performance.....	45
 Copyright.....	46
License.....	46
Conventions.....	46
Version.....	46

VISIO STENCILS

Visio stencils for Nutanix products are available on [VisioCafe](#).



NUTANIX HARDWARE NAMING CONVENTION

Every Nutanix block has a unique name based on the standardized naming convention followed by Nutanix.

The Nutanix hardware model name translates to the following naming convention:

Prefix-Body-Suffix or *NX-WXYZ(G/C/S)-G(4/5/6/7)*

Where:

- **NX** is the Nutanix appliance
- **W** is the product series
- **X** is the number of nodes
- **Y** is the chassis form-factor
- **Z** is the disk form-factor
- **G/C/S** indicates that a platform uses GPUs, a platform is an AHV-only node, or a platform supports only one CPU respectively
- **G(4/5/6/7)** is the CPU generation

Example: **NX-3460-G7**

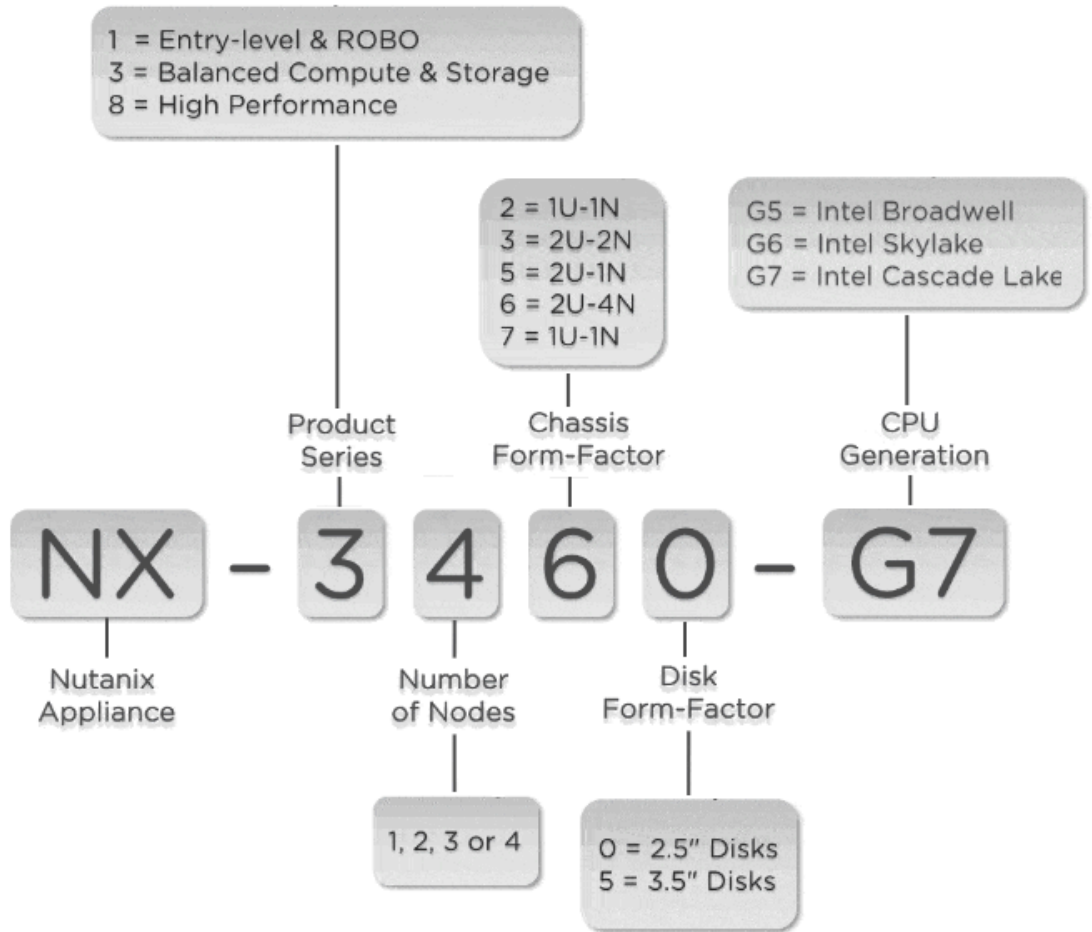

Figure 1: Nutanix Hardware Naming Convention

The following section provides a detailed description of the Nutanix hardware naming convention:

Table 1: Prefix

Prefix	Description
NX	Indicates that the platform is sold directly by Nutanix and support calls are handled by Nutanix. NX stands for <i>Nutanix</i> .

Table 2: Body

Body	Description
W	<p>Indicates the product series and have one of the following values:</p> <ul style="list-style-type: none"> • 1 is for small or Remote Office/Branch Office (ROBO) businesses • 3 is for heavy compute • 5 is for dedicated Files and Buckets • 6 is for heavy storage • 8 is for high-performance • 9 is for high performance and experimental businesses
X	<p>Indicates the number of nodes and have one of the following values:</p> <ul style="list-style-type: none"> • 1 is for single-node platforms • 2 is for multinode platforms • 3 is for multinode platforms • 4 is for multinode platforms <div style="border: 1px solid gray; padding: 5px; margin-top: 10px;"> <p>Note: Though multinode platforms can have two, three, or four nodes, the number is always mentioned as a generic zero, 0 in the documentation.</p> </div>
Y	<p>Indicates the chassis form-factor and have one of the following values:</p> <ul style="list-style-type: none"> • 2 for 1U-1N (one rack unit high with one node) • 3 for 2U-2N (two rack units high with two nodes) • 5 for 2U-1N (two rack units high with one node) • 6 for 2U-4N (two rack units high with four nodes) • 7 for 1U-1N (one rack unit high with one node)
Z	<p>Indicates the drive form-factor and have one of the following values:</p> <ul style="list-style-type: none"> • 0 for 2.5 inch drives • 5 for 3.5 inch drives



Body	Description
<ul style="list-style-type: none"> • G • C • S 	<p>Indicates one of the following:</p> <ul style="list-style-type: none"> • G at the end of the body stands for "graphics" and that the platform is optimized for using the Graphics Processing Unit (GPU) cards. For example, the NX-3155G-G7 platform. • C at the end of the body stands for "cold node" and that the platform is AHV-only. Such platforms should only be used for storage. Cold nodes cannot run VMs. Hence, cold nodes are the only exception where we allow mixing of the nodes with different hypervisors in the same cluster. For example, the NX-6035C and NX-6035C-G5 platforms. • S at the end of the body stands for "single socket" where the motherboard has only one CPU instead of the usual two that we support. For example, the NX-1175S-G7 platform.

Table 3: Suffix

Suffix	Description
G4	Indicates that the platform uses the Intel Haswell CPU
G5	Indicates that the platform uses the Intel Broadwell CPU
G6	Indicates that the platform uses the Intel Skylake CPU
G7	Indicates that the platform uses the Intel Cascade Lake CPU



SYSTEM SPECIFICATIONS

Node Naming (NX-3155G-G4)

Nutanix assigns a name to each node in a block, which varies by product type.

The NX-3155G-G4 block contains a single node named Node A.

Two SSDs contain the Controller VM and metadata. The HDDs are data-only drives. The NX-3155G-G4 supports two SSDs and four HDDs.

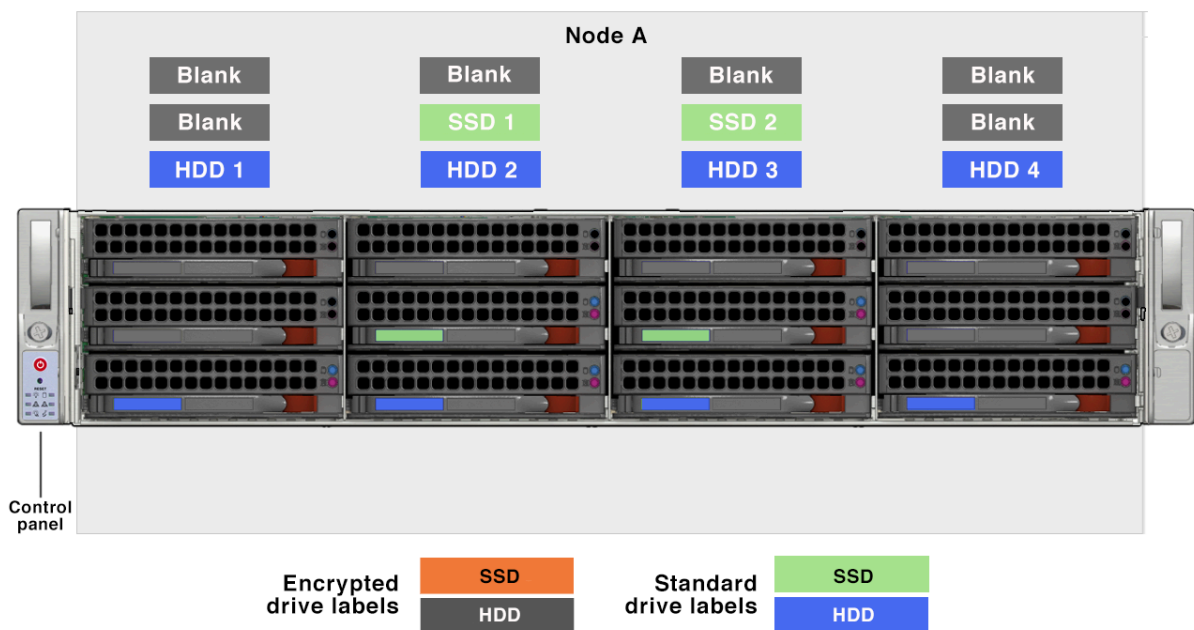

Figure 2: NX-3155G-G4 3.5-inch drive order

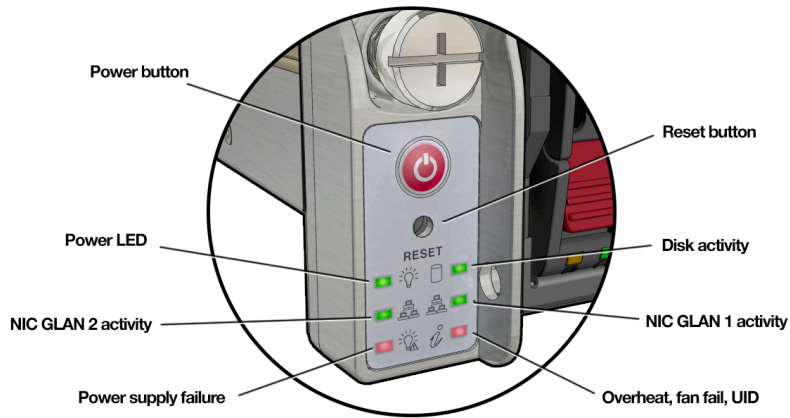

Figure 3: NX-3155G-G4 control panel

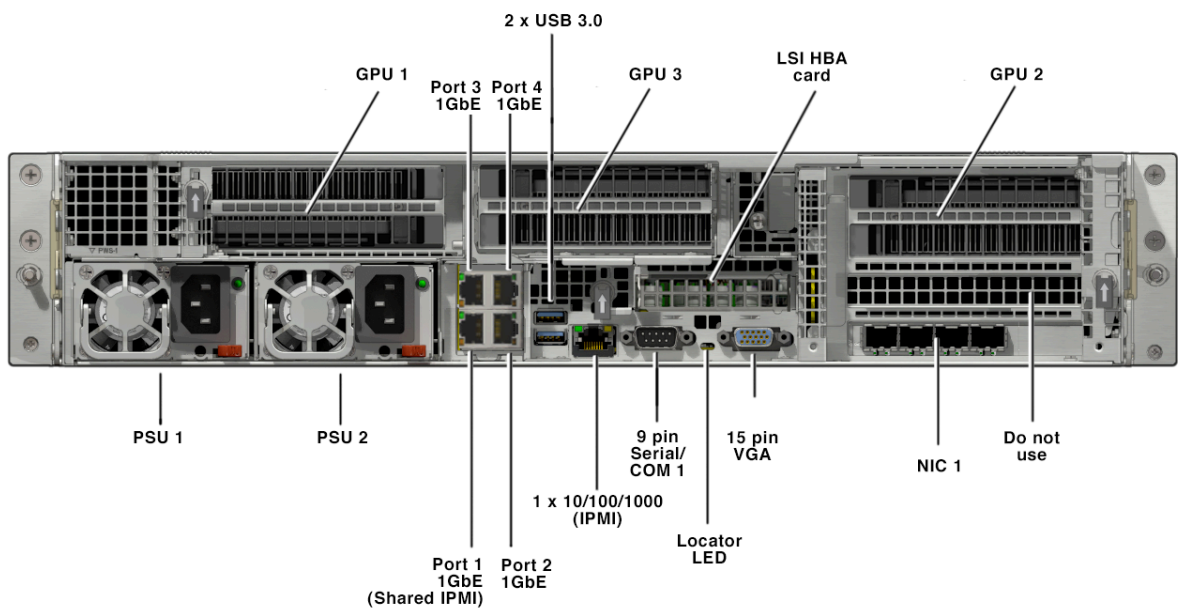

Figure 4: NX-3155G-G4 Back panel

The NX-3155G-G4 supports one NIC. The following figure shows the supported NIC options.

- Quad-port 10 GbE
- Dual-port 10 GbE
- Dual-port 10GBase-T

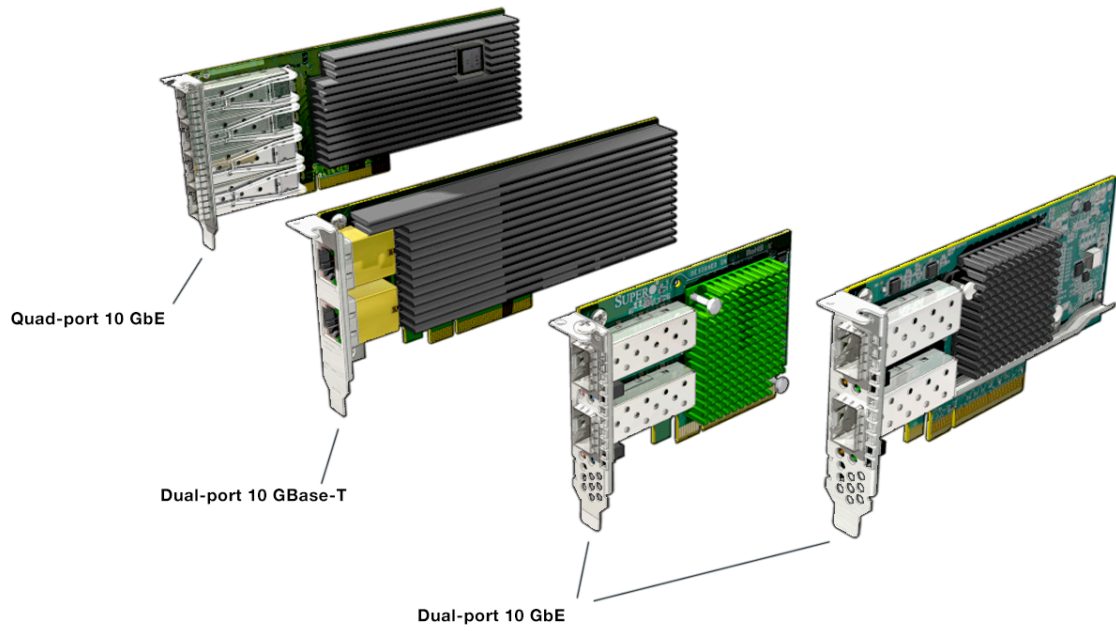

Figure 5: NIC options for the NX-3155G-G4

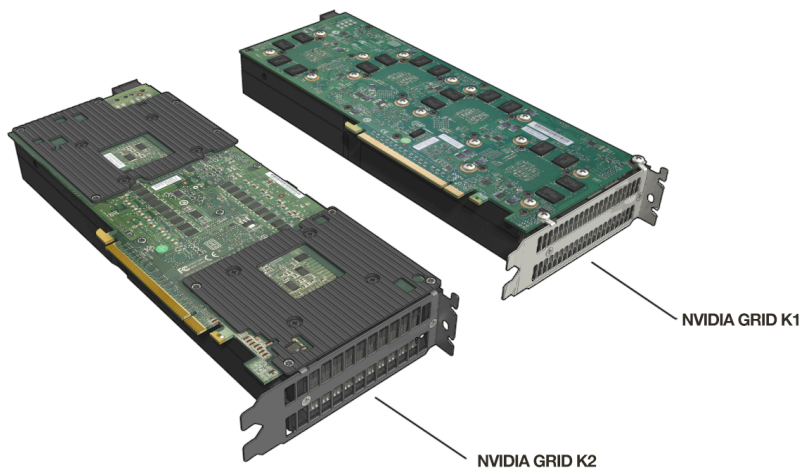

Figure 6: GPU Cards (NVIDIA K1 or K2)

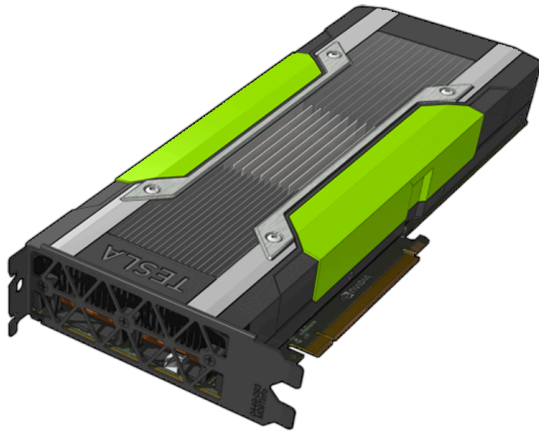

Figure 7: GPU Cards (NVIDIA M10 or M60)

CAUTION: Do not use NVIDIA Tesla M10 and M60 GPU cards on hypervisors running more than 1 TB of total memory, due to NVIDIA M-series architectural limitations.

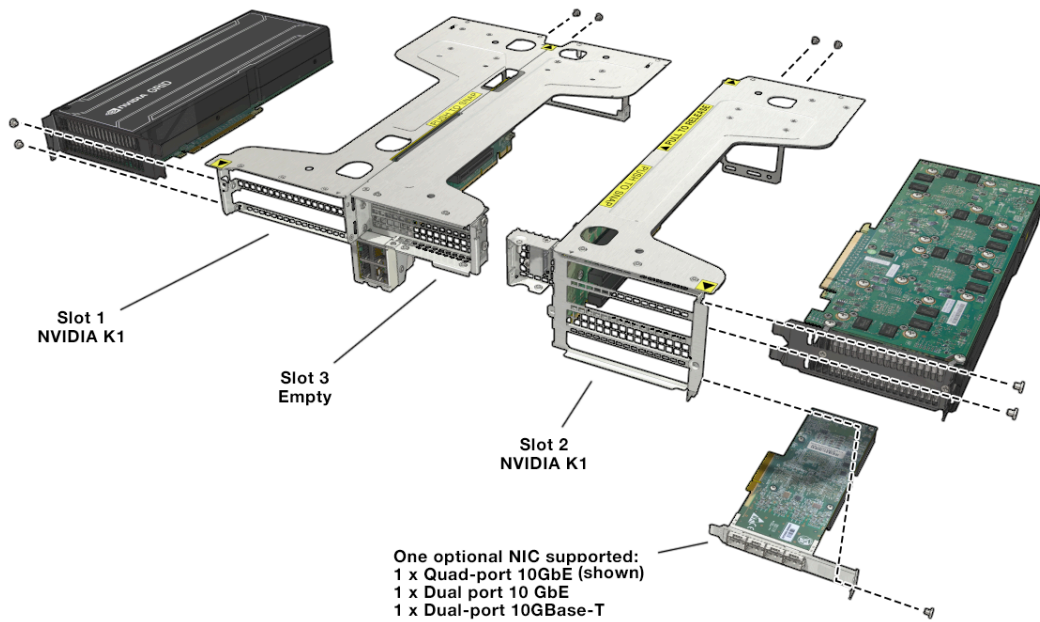

Figure 8: NVIDIA K1 GPU Card and NIC locations for the NX-3155G-G4

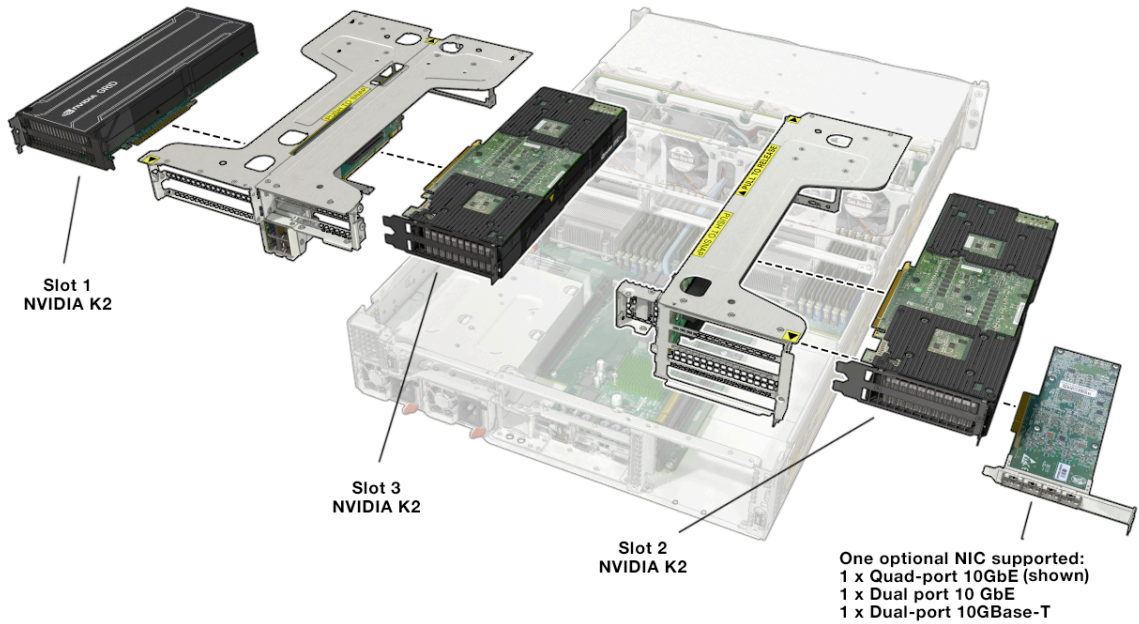

Figure 9: NVIDIA K2 GPU Card and NIC locations for the NX-3155G-G4

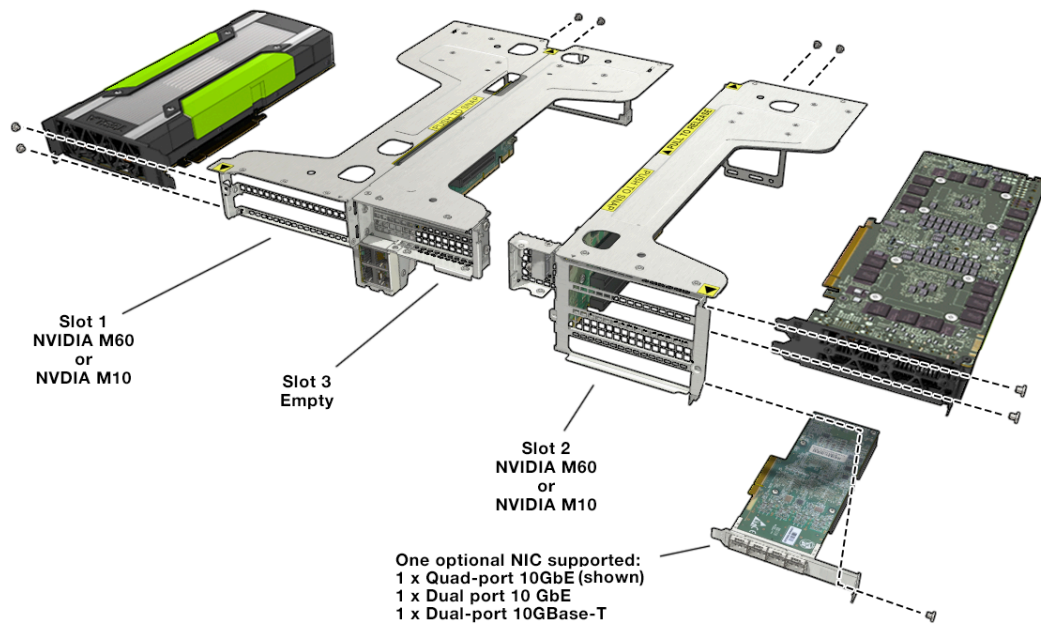

Figure 10: NVIDIA M10 or M60 GPU Card and NIC locations for the NX-3155G-G4

NX-3155G-G4 System Specifications

Table 4: Hardware Components

Nodes	1 node per block (2 rack unit height)
-------	---------------------------------------



CPU options	2 × Intel Xeon E5-2698v3 16-core Haswell @ 2.3 GHz (32 cores total per block)
	2 × Intel Xeon E5-2697v3 14-core Haswell @ 2.6 GHz (28 cores total per block)
	2 × Intel Xeon E5-2680v3 12-core Haswell @ 2.5 GHz (24 cores total per block)
	2 × Intel Xeon E5-2660v3 10-core Haswell @ 2.6 GHz (20 cores total per block)
Storage Options (Hybrid SSD and HDD) in 3.5-inch carriers	2 × solid state drives (SSD) (480 GB, 800 GB, 1.2 TB, or 1.6 TB) with 4 HDDs, either 2 TB, 4 TB, or 6 TB (all drives hot swappable)
	Encrypted SSDs: 2 × 400 GB, 480 GB, 800 GB, 960 GB, 1.6 TB, or 1.92 TB
	Encrypted HDDs: 4 × 2 TB, 4 TB, or 6 TB
Storage Options (All-SSD) in 3.5-inch carriers	4 × hot-swappable solid state drives (SSD) (480 GB, 800 GB, 1.2 TB, or 1.6 TB)
	Encrypted SSDs: 4 × 400 GB, 480 GB, 800 GB, 960 GB, 1.6 TB, or 1.92 TB
SATA DOM	1 × 64 GB SATA DOM
Memory	DDR4-2133, 1.2V, ECC, 16 GB RDIMM or 32 GB RDIMM
	12 × 16 GB = 192 GB
	8 × 32 GB = 256 GB
	12 × 32 GB = 384 GB
	16 × 32 GB = 512 GB
	20 × 32 GB = 640 GB
	24 × 32 GB = 768 GB
On-board Network connections	4 × 1 GbE ports (Port 1 is IPMI failover, or shared IPMI)
	1 × 10/100/1000 GBase-T (IPMI) (serverboard)
Network Interface Card Options (One NIC only)	1 × Dual-port 10 GbE NIC
	1 × Quad-port 10Gbe NIC
	1 × Dual-port 10GBase-T NIC
USB	2 × USB 3.0 ports per node
VGA	1 × VGA connector per node (15 pin female)
Serial RS-232	1 × 9-pin serial port (RS-232)
HBA	1 × x8 lane, PCIe 3.0, LSI Logic 3008 HBA controller card
GPU cards (Populate GPU slots in order: GPU 1, GPU 2, GPU 3).	One or two NVIDIA Grid K1 cards (operates at x16). K1 and K2 cards cannot be mixed.

Note: Each node must contain only DIMMs from the same manufacturer and of the same type, speed, and capacity.



One, two, or three K2 cards (operates at x16). K1 and K2 cards cannot be mixed.

One or two NVIDIA Tesla M10 GPU cards. Supported with ESXi 6.0 or newer only. M10 and M60 cards cannot be mixed.

One or two NVIDIA Tesla M60 GPU cards. Supported with ESXi 6.0 or newer only. M10 and M60 cards cannot be mixed.

Note: K-series and M-series cards cannot be mixed.

Note: The M10 GPU card requires Foundation 3.5 and NCC 2.3.1.

Fans	4 × 80 mm cooling fan modules
------	-------------------------------

Table 5: System Characteristics

Block weight (standalone)	1-node block, standalone: 60.63 lbs. (27.52 kg) Package with rack rails and accessories: 78 lbs (35.38 kg) (Accessory kit includes rack rail kit, bezel, power cords, networking cables.)
Block form factor	2U rack-mount chassis
Block dimensions	Height: 88 mm (3.46 in) Chassis width (chassis sheet metal at rack rail tabs) 446 mm (17.56 in) Chassis width (with ear control panels): 489 mm (19.25 in) Depth (from rear PCIe release latches to front of chassis pull rings and bezel): 793 mm (31.22 in)
Rack Rail Length	Minimum: 676 mm (26.61 in) Maximum 1520 mm (59.84 in)

Table 6: Block Power and Electrical

Power supplies	2 × 1600W redundant, hot-swappable, auto-ranging power supplies 80 PLUS Titanium Certified (100 - 240V only) 1000W Output @ 100 - 127Vac, 13 - 9A, 50 - 60Hz 1600W Output @ 200 - 240Vac, 10 - 8A, 50 - 60Hz
----------------	---



Block power consumption with two E5-2698V3 CPUs, 24 × 32 GB DIMMs (768 GB)	1492W maximum, 1350W typical Amps @ 110V 13.5 Amps @ 208V 7.1
Thermal dissipation	5092 BTU/hr maximum, 4607 BTU/hr typical
PSU Redundancy	Power supplies are redundant with 208V only

Table 7: Operating Environment

Operating temperature	50° to 95° F (10° to 35° C)
Nonoperating temperature	-40° to 140° F (-40° to 60° C)
Operating relative humidity	8% to 90% (non-condensing)
Nonoperating relative humidity	5% to 95% (non-condensing)

Table 8: Minimum Firmware and Software Versions When Using a GPU card

Firmware or Software	NVIDIA K1 or K2	NVIDIA Tesla M60	NVIDIA Tesla M10
BIOS	1.0c 5/1/2015 (G4U1-1)	G4U-1.5e	G4U-1.32
BMC	1.92	3.28	3.35
Hypervisor	ESXi or Hyper-V	<ul style="list-style-type: none"> AHV ESXi 6.0 or newer <div style="border: 1px solid gray; background-color: #f0f0f0; padding: 5px; margin-top: 5px;">CAUTION: Do not use an M60 GPU card on hypervisors running more than 1TB of total memory.</div>	<ul style="list-style-type: none"> AHV ESXi 6.0 or newer <div style="border: 1px solid gray; background-color: #f0f0f0; padding: 5px; margin-top: 5px;">CAUTION: Do not use an M10 GPU card on hypervisors running more than 1TB of total memory.</div>
Foundation	2.1.1	3.1.1 or newer	3.5
AOS	AOS 4.1.3	4.6.1	4.7.2
NCC		2.2.4	2.3.1
NVIDIA vGPU Driver	<ul style="list-style-type: none"> ESXi 5.1.0: 304.76 ESXi 5.5.0: 319.65 ESXi 6.0: 346.42 Hyper-V: 333.11 	ESXi 6.0: 352.83	ESXi 6.0: 367.43
Supported modes	vdGA, vSGA, vGPU	vGPU only	vGPU only



Table 9: Firmware and Acropolis Operating System

Component	Version
Minimum AOS	AOS 4.7 branch: 4.7 (4.7.2 if using 3.84 TB SSD)
	AOS 5.0 branch: 5.0
Super Micro BIOS and BMC IPMI firmware	BIOS G4U-1.5e and BMC 1.97
Minimum Foundation Version	3.4
Intel S3610 SAS SSD firmware (480 GB, 800 GB, 1.2 TB, 1.6 TB)	G2010140
Seagate Constellation SATA HDD firmware (2 TB, 4 TB)	SN04
Seagate Constellation SATA HDD firmware (6 TB)	SN02
HGST SATA HDD (2 TB or 6 TB)	APGNT7JO
Seagate SAS SED FIPS HDD (Constellation) firmware (2 TB, 4 TB)	0004
Seagate Enterprise Capacity SAS SED FIPS HDD firmware (6 TB drives)	EF01
HGST SED FIPS SSD (400 GB, 800 GB, 1.6 TB)	HGST SSC+: D2C0
New Silicom Quad-port 10 GbE SFP+ NIC driver and firmware (with Intel 82559 chip)	Driver: ixgbe 3.15.1-k, Firmware: 0x800006d1
Silicom Dual-port 10 GbE SFP+ NIC driver and firmware	Driver: ixgbe 3.15.1-k, Firmware: 0x800000cb
Supermicro 10 GbE NIC driver and firmware	Driver: ixgbe 3.15.1-k, Firmware: 0x800006da
Supermicro Riser card (4-port onboard 10GBaseT NIC)	Driver: igb 5.0.5-k, Firmware 1.63, 0x800009fa
Silicom Dual-port 10GBase-T NIC driver and firmware	Driver: ixgbe 3.15.1-k, Firmware: 0x80000528
Super Micro LSI HBA card firmware	MPTFW-06.00.00.00-IT, MPT3BIOS-8.13.00.00, EFI BIOS: 07.00.00.00
Innodisk SATA DOM	S140714
Innodisk SATA DOM SL-3IE3 V2	S560301N



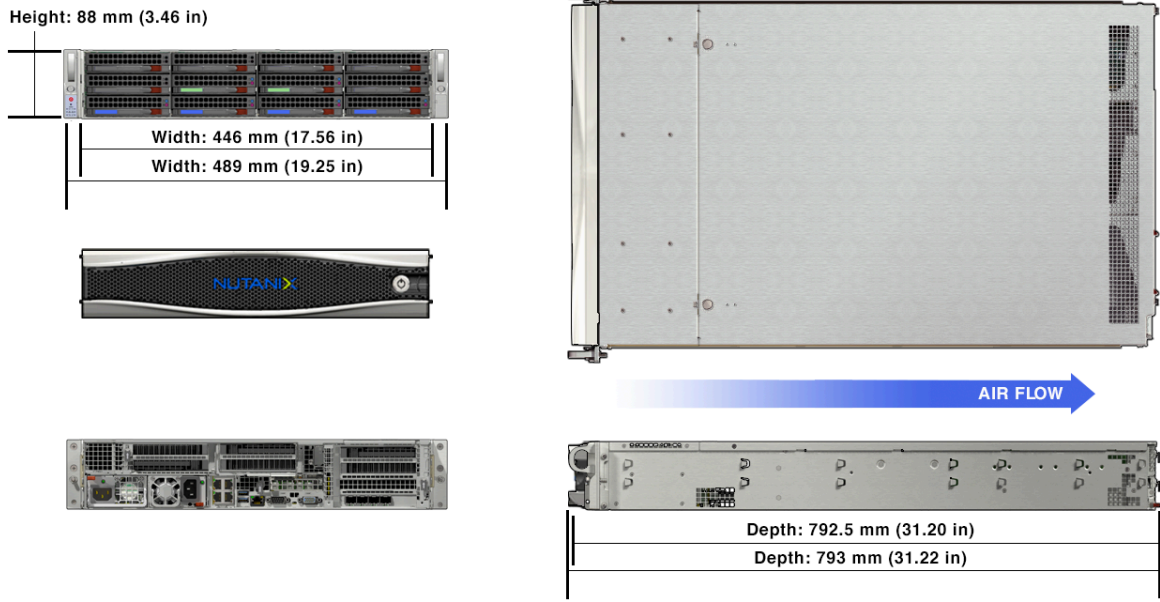

Figure 11: NX-3155G-G4 chassis dimensions

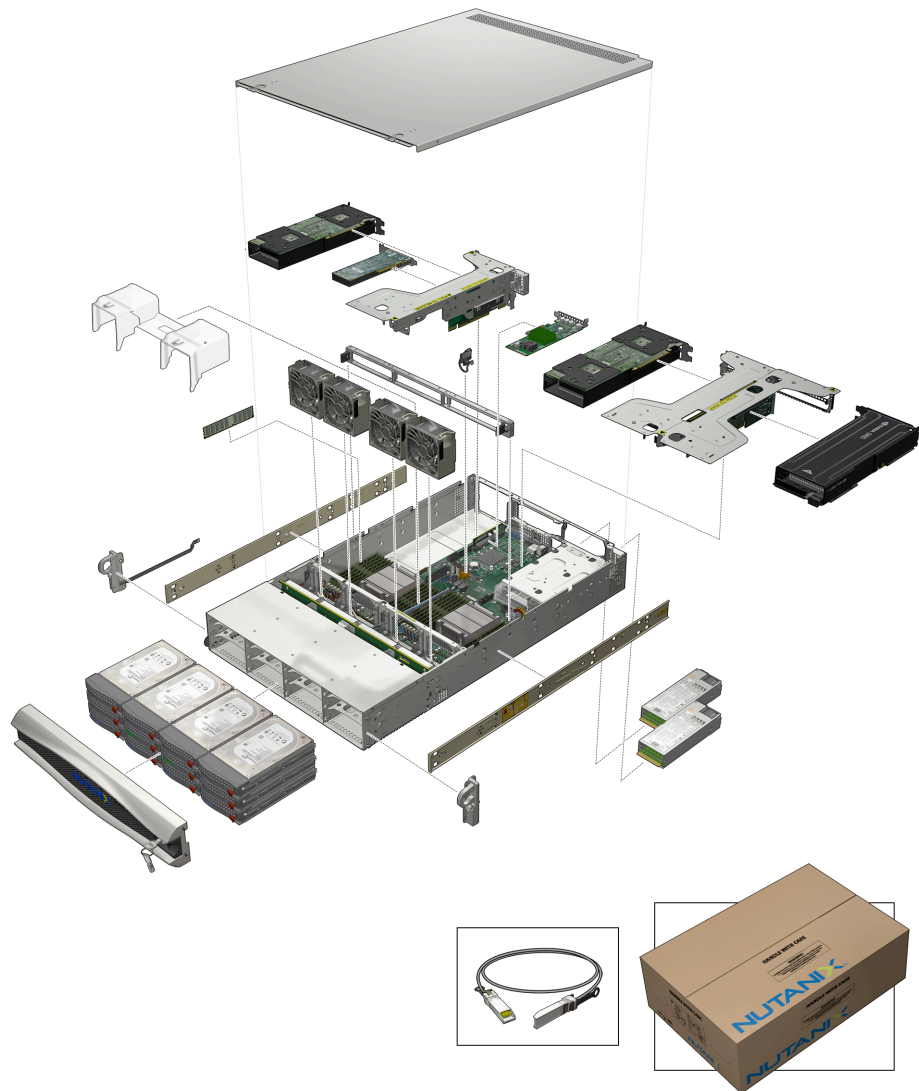

Figure 12: NX-3155G-G4 components

Node Naming (NX-3175-G4)

Nutanix assigns a name to each node in a block, which varies by product type.

The NX-3175-G4 block contains a single node named Node A.

Two SSDs contain the Controller VM and metadata. Two HDDs (if used) are data-only drives.

Node A

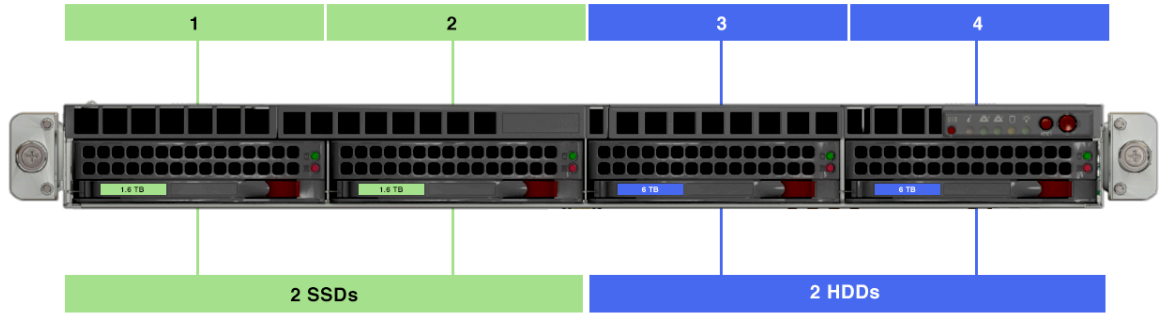

Figure 13: NX-3175-G4 3.5-inch drive order

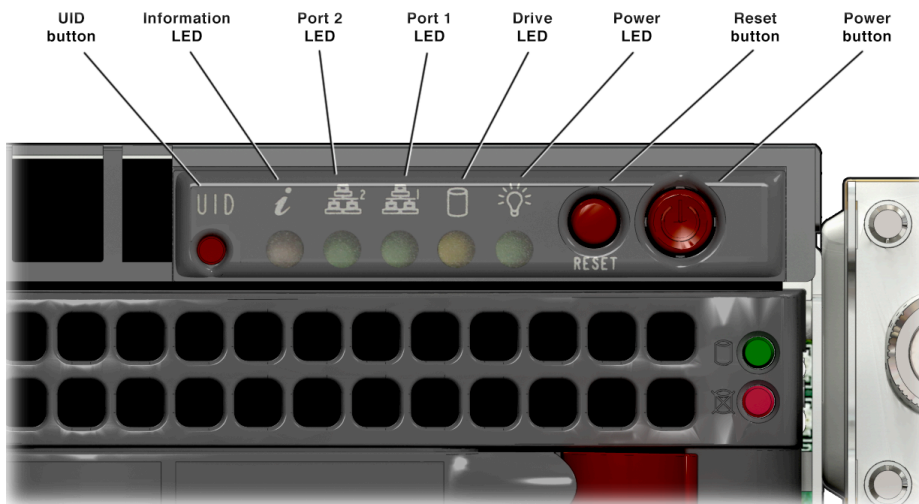

Figure 14: NX-3175-G4 control panel

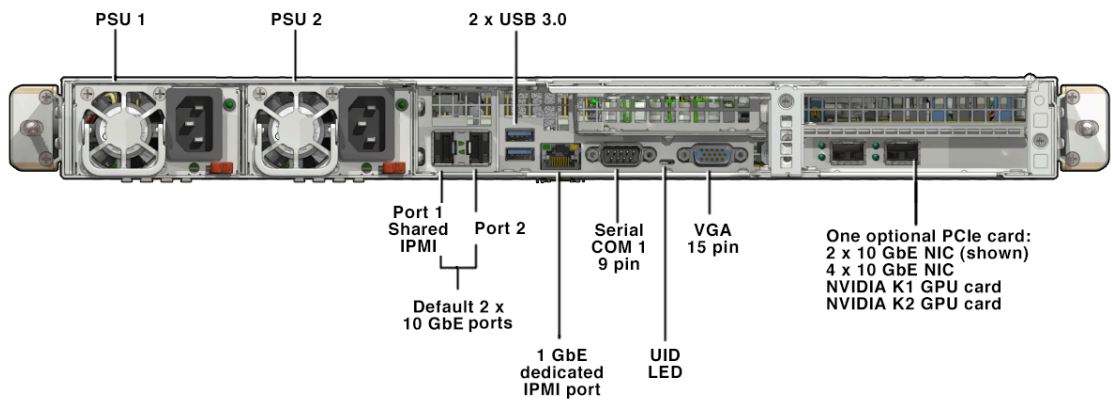

Figure 15: NX-3175-G4 Back panel

The NX-3175-G4 always contains one LSI HBA card in the left slot. You can choose either one NIC or one NVIDIA GPU card in the right PCIe slot.

CAUTION: NVIDIA M10 and M60 GPU cards should not be used on hypervisors running more than 1TB of total memory, due to NVIDIA M-series architectural limitations.

See the *System Specifications* for LED information.

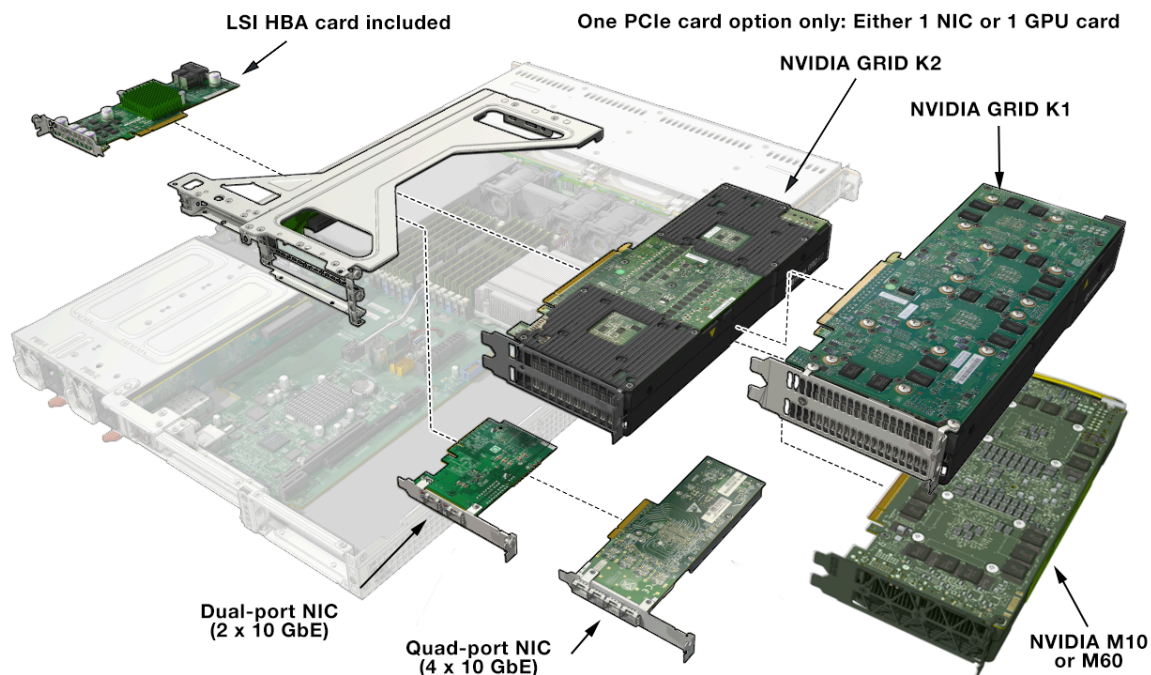

Figure 16: PCIe Card Locations

NX-3175-G4 Series System Specifications

Table 10: Hardware Components

Nodes	1 node per block (1 rack unit height)
CPU options	2 × Intel Xeon E5-2699v3 18-core Haswell @ 2.3 GHz (36 cores total per block)
	2 × Intel Xeon E5-2697v3 14-core Haswell @ 2.6 GHz (28 cores total per block)
	2 × Intel Xeon E5-2680v3 12-core Haswell @ 2.5 GHz (24 cores total per block)
	2 × Intel Xeon E5-2660v3 10-core Haswell @ 2.6 GHz (20 cores total per block)
Storage (Hybrid SSD and HDD) in 3.5-inch carriers	2 × hot-swappable solid state drives (SSD) (480 GB, 800 GB, 1.2 TB, or 1.6 TB)
	2 × hot-swappable hard disk drives (HDD) (2 TB, 4 TB, or 6 TB)



	Encrypted SSDs: 2 × hot-swappable SED SSD (400 GB, 800 GB)
	Encrypted HDDs: 2 × hot-swappable SED HDD, 2 TB
Storage (All-SSD) in 3.5-inch carriers	4 × hot-swappable solid state drives (SSD) (480 GB, 800 GB, 1.2 TB, or 1.6 TB)
	Encrypted drives: 4 × hot-swappable SED SSD (400 GB, 480 GB, 800 GB, 960 GB, 1.92 TB)
SATA DOM	1 × 64 GB SATA DOM
Memory	DDR4-2133, 1.2V, ECC, 16 GB RDIMM, 32 GB RDIMM, or 32 GB LRDIMM
	12 × 16 GB = 192 GB
	16 × 16 GB = 256 DIMM
	24 × 16 GB = 384 GB
	8 × 32 GB = 256 GB
	12 × 32 GB = 384 GB
	16 × 32 GB = 512 GB
	20 × 32 GB = 640 GB
	24 × 32 GB = 768 GB
On-board Network connections	2 × 10 GbE SFP+ (riser card on serverboard) 1 × 1 GbE BASE-T (IPMI) (serverboard)
Network Interface Card Options (One NIC only)	1 × Dual-port 10 GbE NIC, or 1 × Quad-port 10GbE NIC
USB	2 × USB 3.0 ports per node
VGA	1 × VGA connector per node (15 pin female)
Serial RS-232	1 × 9-pin serial port (RS-232)
HBA	1 × 8 lane, PCIe 3.0, LSI Logic 3008 HBA controller card
Supported graphics cards	1 × NVIDIA Grid K1 or K2 card (operates at x16.) (One card per block.) Graphics cards are supported for ESXi and Hyper-V hypervisors only.
	1 × NVIDIA Tesla M10 or M60 GPU card. (One card per block.) vGPU Mode only. Supported with ESXi 6.0 or newer only.
	Note: The M10 GPU card requires Foundation 3.5 and NCC 2.3.1.
Fans	8 × 40 mm × 56 mm cooling fan modules



Table 11: System Characteristics

Block weight (standalone)	1-node block, standalone: 33 lbs. (14.9 kg)
	Package with rack rails and accessories: 46 lbs (20.9 kg)
Block form factor	1U rack-mount chassis
Block dimensions	Height: 43 mm (1.70 in)
	Chassis width (rack mounting ear to ear) 485 mm (19.09 in)
	Chassis width (sheet metal): 442 mm (17.40 in)
	Depth (From rear sheet metal to front rack mount nut): 754 mm (29.69 in)
	Depth (From rear sheet metal to front of bezel): 782 mm (30.79 in)

Table 12: Block Power and Electrical

Power supplies	2 × 1000W redundant, hot-swappable, auto-ranging power supplies
	80 PLUS Titanium Certified (100 - 240V only)
	800W Output @ 100 - 120Vac, 9.8 - 7A, 50 - 60Hz
	1,000W Output @ 200 - 240Vac, 7A - 5A, 50 - 60Hz
Block power consumption	770W maximum, 690W typical. A GPU card adds up to 220W.
Thermal dissipation	2627 BTU/hr maximum, 2354 BTU/hr typical

Table 13: Operating Environment

Operating temperature	50° to 95° F (10° to 35° C)
Nonoperating temperature	-40° to 140° F (-40° to 60° C)
Operating relative humidity	8% to 90% (non-condensing)
Nonoperating relative humidity	5% to 95% (non-condensing)

Table 14: Minimum Firmware and Software Versions When Using a GPU card

Firmware or Software	NVIDIA K1 or K2	NVIDIA Tesla M60	NVIDIA Tesla M10
BIOS	1.0c 5/1/2015 (G4U1-1)	G4U-1.5e	G5U-1.32
BMC	1.92	3.28	3.35



Firmware or Software	NVIDIA K1 or K2	NVIDIA Tesla M60	NVIDIA Tesla M10
Hypervisor	ESXi or Hyper-V	<ul style="list-style-type: none"> AHV ESXi 6.0 or newer 	<ul style="list-style-type: none"> AHV ESXi 6.0 or newer
Foundation	2.1.1	3.1.1 or newer	3.5
AOS	AOS 4.1.3	4.6.1	4.7.2
NCC		2.2.4	2.3.1
NVIDIA vGPU Driver	<ul style="list-style-type: none"> ESXi 5.1.0: 304.76 ESXi 5.5.0: 319.65 ESXi 6.0: 346.42 Hyper-V: 333.11 	ESXi 6.0: 352.83 CAUTION: Do not use the M60 GPU card on hypervisors running more than 1TB of total memory.	ESXi 6.0: 367.43 CAUTION: Do not use the M10 GPU card on hypervisors running more than 1TB of total memory.
Supported modes	vdGA, vSGA, vGPU	vGPU only	vGPU only

Table 15: Minimum Firmware and Software Versions When Not Using a GPU Card

Component	Version
This table shows minimum firmware without a GPU card installed. See the GPU card table above for more information.	
Minimum Acropolis Operating System	AOS 4.7 branch: 4.7 AOS 5.0 branch: 5.0
Minimum Foundation Version	
Intel S3610 SATA-SSD firmware (480 GB, 800 GB, 1.2 TB, 1.6 TB)	G2010110
Seagate SATA HDD firmware (2 TB, 4 TB)	SN04
Seagate SATA HDD firmware (6 TB drives)	SN02
HGST SATA HDD firmware (2 TB, 6 TB)	APGNT517
Seagate SAS SED FIPS HDD firmware (2 TB and 4 TB)	0004
Seagate SAS SED FIPS HDD firmware (6 TB drives)	EF01
HGST SED FIPS SSD (400 GB, 800 GB)	HGST SSC+:D218
Super Micro 10 GbE NIC driver (on-board riser card, LAN 1 and LAN 2)	ixgbe 3.15.1-k
Super Micro 1 GbE NIC firmware (on-board riser card, LAN 1 and LAN 2)	0x800004e0



Component	Version
Super Micro 10 GbE NIC driver (optional NIC)	ixgbe 3.15.1-k
Super Micro 10 GbE NIC firmware (optional NIC)	0x80000208
Silicom dual-port 10 GbE SFP+ NIC firmware	0x800000cb
Silicom dual-port 10 GbE SFP+ NIC driver	ixgbe 3.15.1-k
Silicom quad-port 10 GbE SFP+ NIC firmware	f4.22 a1.2 n04.26 e800014ab
Silicom quad-port 10 GbE SFP+ NIC driver	i40e 1.2.38
Super Micro LSI HBA card firmware	MPTFW-06.00.00.00-IT, MPT3BIOS-8.13.00.00
Super Micro BIOS and BMC IPMI firmware	BIOS 1.0c (Nutanix G4U-1.1) and BMC 1.92
Innodisk SATA DOM	S140714
Innodisk SATA DOM SL-3IE3 V2	S560301N

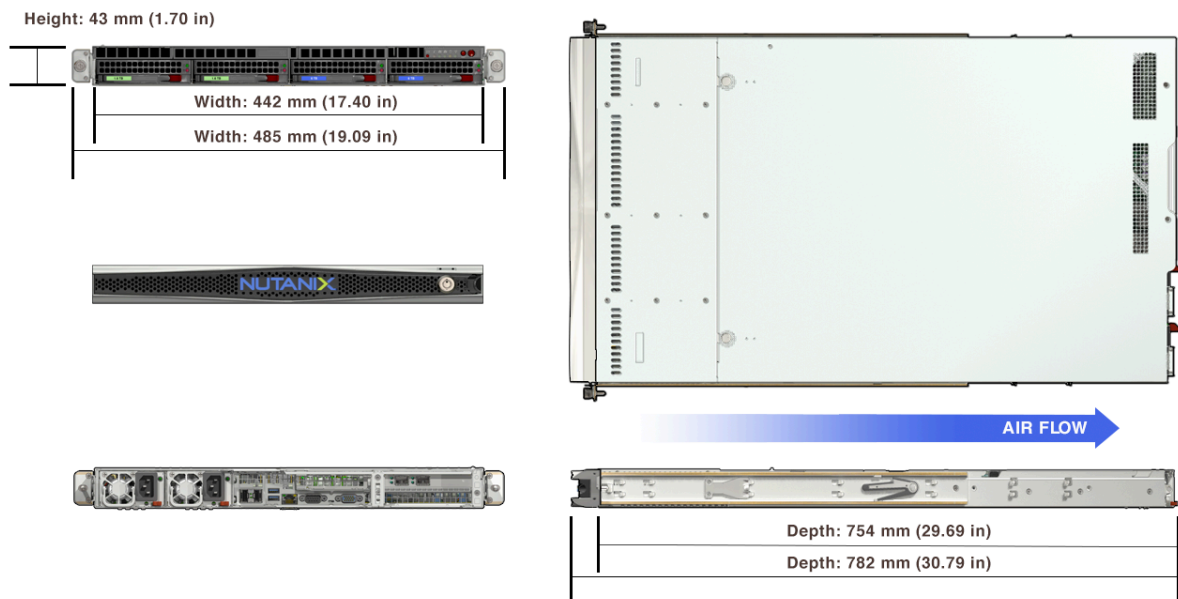

Figure 17: NX-3175-G4 chassis dimensions

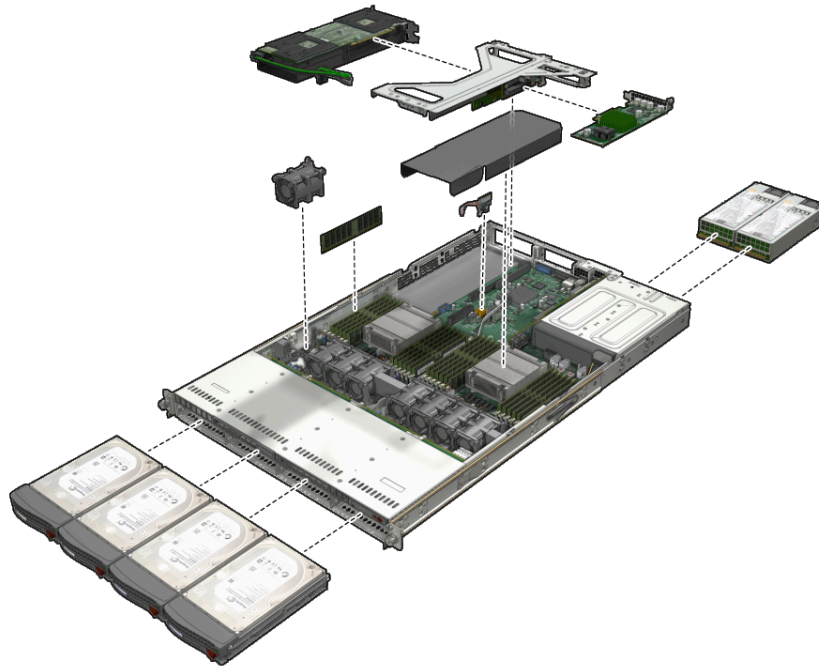

Figure 18: NX-3175-G4 replaceable components

Node Naming (NX-8150-G4)

Nutanix assigns a name to each node in a block, which varies by product type.

The NX-8150-G4 block contains a single node named Node A.

The NX-8150-G4 supports 4 SSDs and 20 HDDs. Two SSDs contain the Controller VM and metadata. All HDDs (if used) are data-only drives.

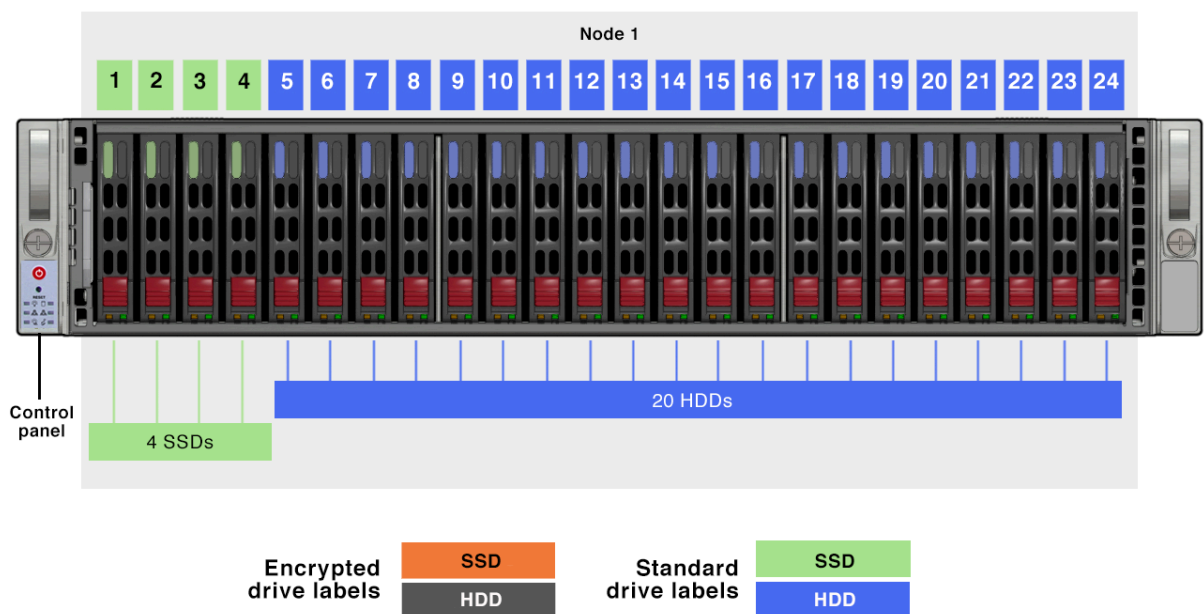

Figure 19: 2.5-inch drive order

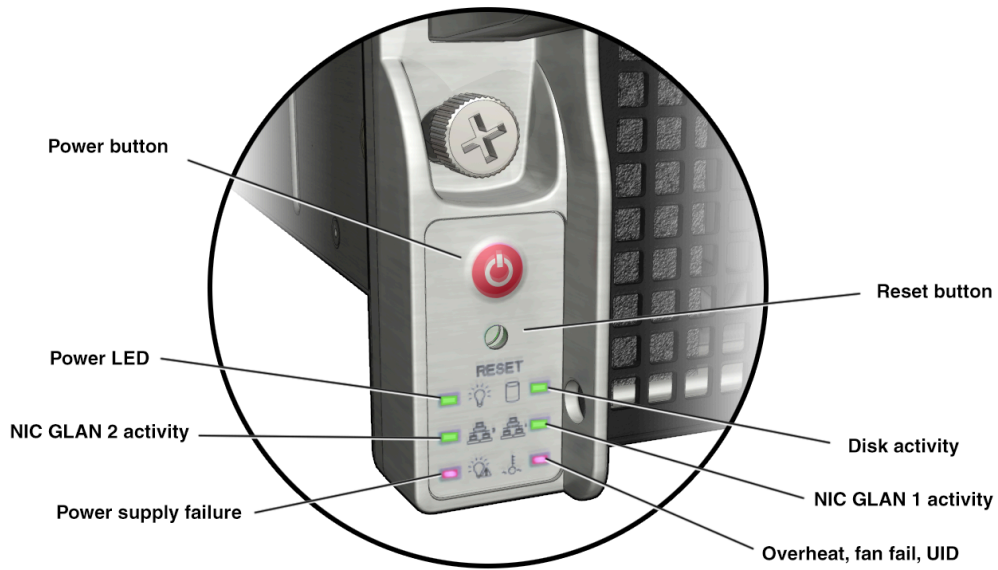

Figure 20: Control panel

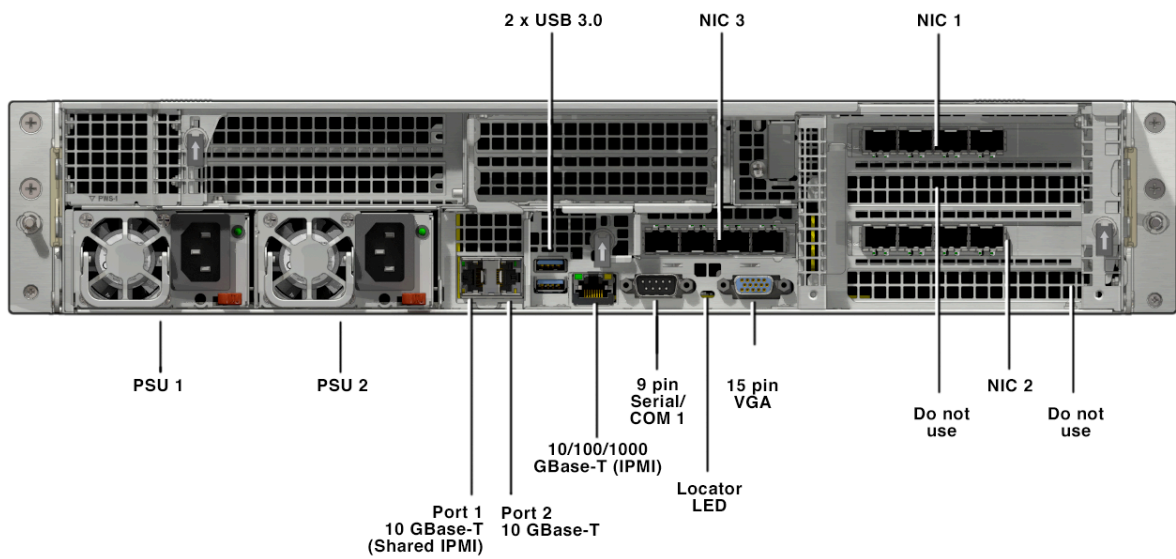

Figure 21: NX-8150-G4 Back panel

You can install one to three NICs. All installed NICs must be identical. Always populate the NIC slots in order: NIC1, NIC2, NIC3.

- Quad-port 10 GbE (one to three NICs)
- Dual-port 10 GbE (one to three NICs)
- Dual-port 10GBase-T (one or two NICs)

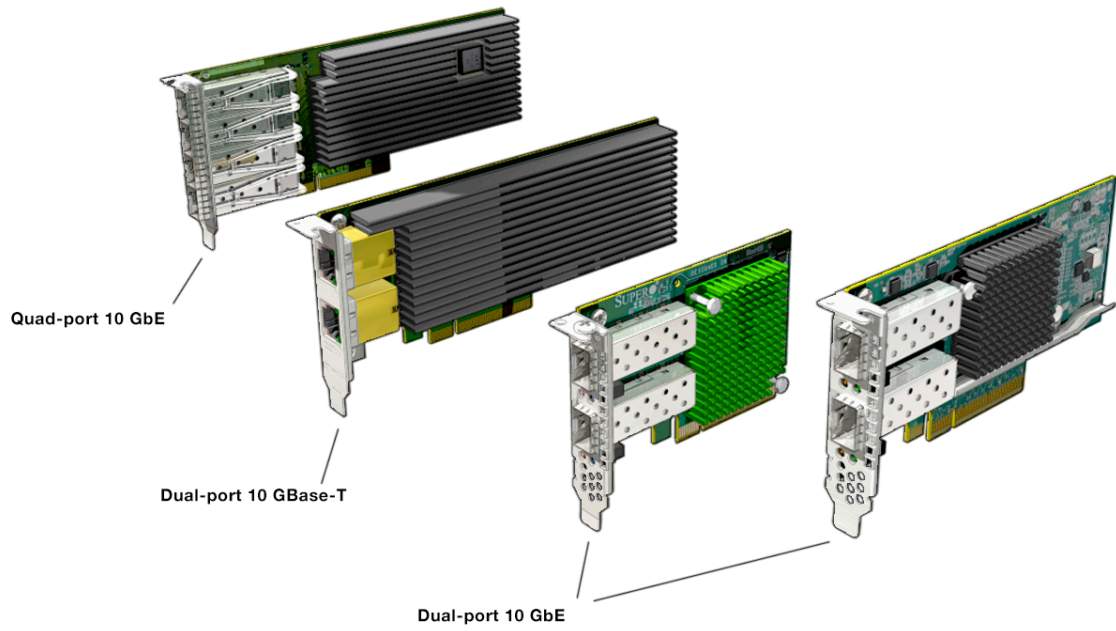

Figure 22: NIC options

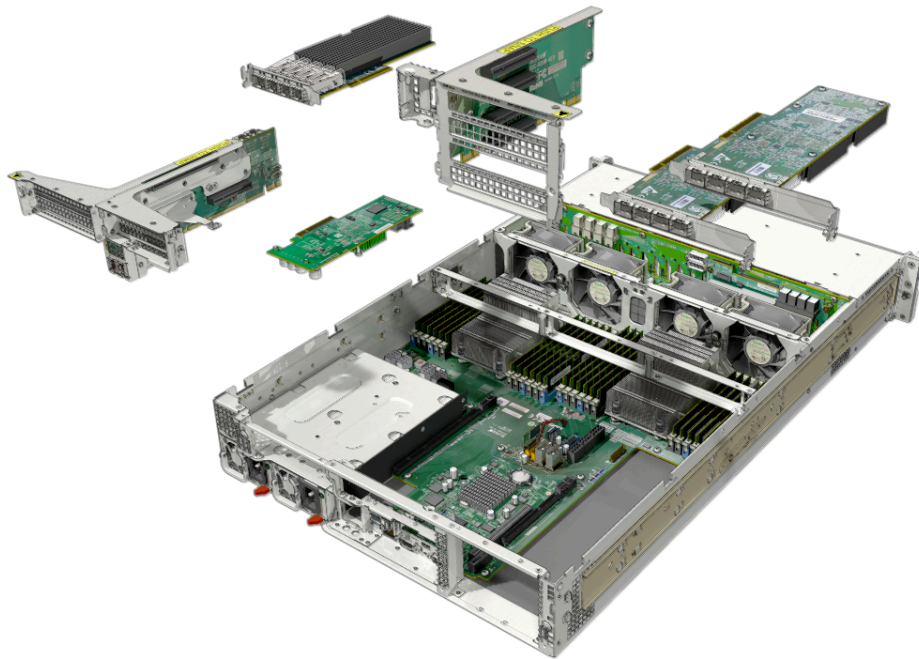

Figure 23: NX-8150-G4 LSI HBA card and NIC locations

NX-8150-G4 System Specifications

Note:



- Encrypted drives (SED) can be mixed with unencrypted (non-SED) drives in the same node, if encryption has never been enabled.
Encrypted nodes can be mixed with unencrypted nodes in the same cluster if encryption was never enabled and remains disabled.

Table 16: Hardware Components

Nodes	1 node per block (2 rack unit height)
CPU options	2 × Intel Xeon E5-2699v3 18-core Haswell @ 2.3 GHz (36 cores total per block)
	2 × Intel Xeon E5-2697v3 14-core Haswell @ 2.6 GHz (28 cores total per block)
	2 × Intel Xeon E5-2680v3 12-core Haswell @ 2.5 GHz (24 cores total per block)
	2 × Intel Xeon E5-2667v3 8-core Haswell @ 3.2 GHz (16 cores total per block)
Storage Options (drives in 2.5-inch carriers)	Supported drive combinations are shown below.
	4 × solid state drives (SSD) (480 GB, 800 GB, 1.2 TB, or 1.6 TB) with 20 HDDs, either 1 TB or 2 TB (all drives hot swappable)
	Encrypted drives: 4 × solid state drives (SED SSD) (400 GB, 480 GB, 800 GB, 960 GB, 1.6 TB, or 1.92 TB) with 20 HDDs, either 1 TB or 2 TB (all drives hot swappable)
	<ul style="list-style-type: none"> • Encrypted drives (SED) can be mixed with unencrypted (non-SED) drives in the same node, if encryption has never been enabled. Encrypted nodes can be mixed with unencrypted nodes in the same cluster if encryption was never enabled and remains disabled.
SATA DOM	1 × 64 GB SATA DOM
Memory	DDR4-2133, 1.2V, ECC, 16 GB RDIMM or 32 GB RDIMM
	8 × 16 GB = 128 GB
	12 × 16 GB = 192 GB
	8 × 32 GB = 256 GB
	12 × 32 GB = 384 GB
	16 × 32 GB = 512 GB
	20 × 32 GB = 640 GB
	24 × 32 GB = 768 GB
On-board Network connections	2 × 10 GBase-T ports (Port 1 is IPMI failover)

Note: Each node must contain only DIMMs from the same manufacturer and of the same type, speed, and capacity.



	1 × 10/100/1000 GbaseT (IPMI port)
Network Interface Card Options (All installed NICs must be the same type.)	1 to 3 Dual-port 10 GbE NICs 1 to 3 Quad-port 10Gbe NIC 1 or 2 Dual-port 10GBase-T NICs
USB	2 × USB 3.0 ports per node
VGA	1 × VGA connector per node (15 pin female)
Serial RS-232	1 × 9-pin serial port (RS-232)
HBA	1 × x8 lane, PCIe 3.0, LSI Logic 3008 HBA controller card
Fans	4 × 80 mm cooling fan modules

Table 17: System Characteristics

Block weight and package information (standalone)	1-node block, standalone: 47.5 lbs. (21.54 kg)
	Package with rack rails and accessories: 74 lbs (33.56 kg) (Accessory kit includes rack rail kit, bezel, power cords, networking cables.)
	Package dimensions: 38" × 25.5" × 12" (965 mm × 648 mm × 305 mm)
Block form factor	2U rack-mount chassis
Block dimensions	Height: 88 mm (3.46 in)
	Chassis width (chassis sheet metal at rack rail tabs) 446 mm (17.56 in)
	Chassis width (with ear control panels): 484 mm (19.56 in)
	Depth (from rear PCIe release latches to front of chassis pull rings): 763 mm (30.04 in)
Rack Rail Length	Depth (from rear PCIe release latches to bezel): 764 mm (30.08 in)
	Minimum: 676 mm (26.61 in) Maximum: 1520 mm (59.84 in)

Table 18: Block Power and Electrical

Power supplies	2 × 1000W redundant, hot-swappable, auto-ranging power supplies
	80 PLUS Titanium Certified (100 - 240V only)
	800W Output @ 100 - 120Vac, 9.8 - 7A, 50 - 60Hz
	1,000W Output @ 200 - 240Vac, 7A - 5A, 50 - 60Hz



Block power consumption with 2 × E5-2699V3 CPUs, and 24 × 16 GB DIMMs (384 GB)	650W maximum, 400W typical Amps @ 110V 6.30 Amps @ 208V 3.125
Thermal dissipation	2217 BTU/hr maximum, 1364 BTU/hr average
PSU Redundancy	Power supplies are redundant at both 110V and 208V

Table 19: Operating Environment

Operating temperature	50° to 95° F (10° to 35° C)
Nonoperating temperature	-40° to 158° F (-40° to 70° C)
Operating relative humidity	8% to 95% (non-condensing)
Nonoperating relative humidity	5% to 95% (non-condensing)

Table 20: Firmware and AOS

Component	Version
Minimum AOS	4.5.0.2
Super Micro BIOS and BMC IPMI firmware	BIOS: G4U-1.5e and BMC 1.97
Minimum Foundation Version	3.0.2
Intel S3610 SATA SSD firmware (480 GB, 800 GB, 1.2 TB, 1.6 TB)	G2010140
Seagate SAS STD HDD firmware (1 TB, 2 TB)	E002
Seagate SAS SED FIPS HDD firmware (1 TB)	0004
Seagate SAS SED FIPS HDD firmware (2 TB drives)	EF02
HGST SED FIPS SSD (400 GB, 800 GB, 1.6 TB)	HGST SSC+: D2C0
New Silicom Quad-port 10 GbE SFP+ NIC (with Intel 82559 chip) driver and firmware	Driver: ixgbe 3.15.1-k, Firmware: 0x800006d1
Silicom Dual-port 10GBase-T NIC driver and firmware	Driver: ixgbe 3.15.1-k, Firmware: 0x80000313, 0x80000528
Silicom Dual-port 10 GbE SFP+ NIC driver and firmware	Driver: ixgbe 3.15.1-k, Firmware: 0x800000cb
Supermicro 10 GbE NIC driver and firmware	Driver: ixgbe 3.15.1-k, Firmware: 0x80000208
Super Micro LSI HBA card firmware	MPTFW-06.00.00.00-IT, MPT3BIOS-8.13.00.00, EFI BIOS: 07.00.00.00
Innodisk SATA DOM	S140714



Component	Version
Innodisk SATA DOM SL-3IE3 V2	S560301N

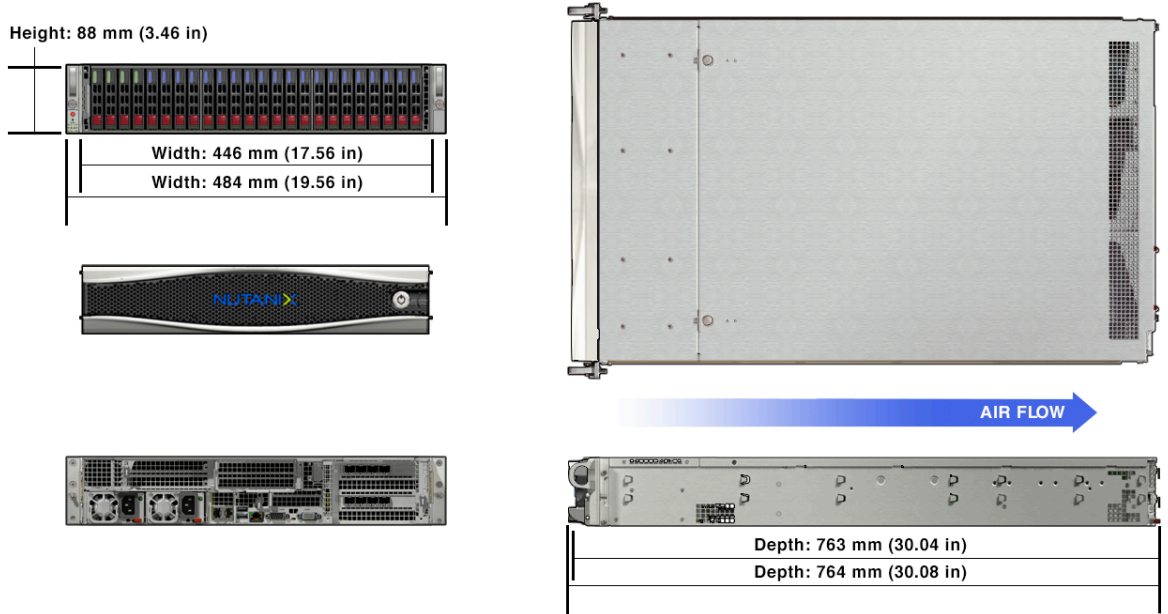

Figure 24: NX-8150-G4 chassis dimensions

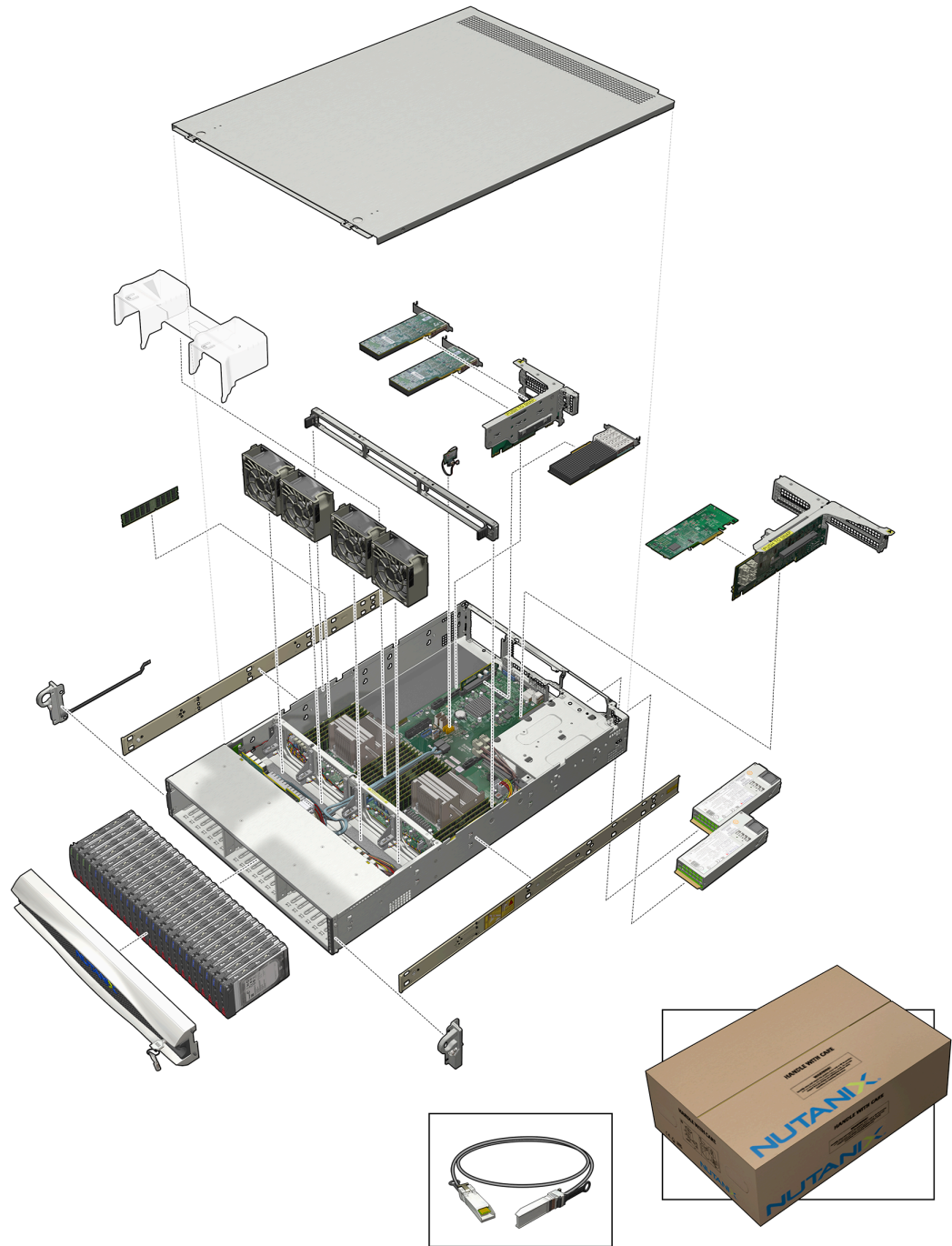

Figure 25: NX-8150-G4 components

COMPONENT SPECIFICATIONS

LEDs and Controls for 2U1N Platforms

Table 21: Front Panel Controls and Indicators

LED or Button	Function
Power button	System on/off (Press and hold 4 seconds to power off.)
Reset button	System reset
Power LED	Solid green when block is powered on
Disk Activity LED	Activity = green flashing
NIC LAN 1 Activity	Activity = green flashing
Multiple Function LEDs	
<i>i</i> Unit identification	Solid blue
<i>i</i> Overheat, fan fail, unit identification	System Overheat: Solid red , Fan fail = flashing red at 1Hz, Power failure = flashing red at .25 Hz, Blinking blue = UUID has been activated.

Table 22: Drive LEDs

Top LED: Activity	Blue or green: Blinking = I/O activity, off = idle
Bottom LED: Status	Solid red = failed drive, On five seconds after boot = power on

Table 23: Back Panel Controls and Indicators

LED	Function
PSU1 and PSU2 LED	Green = OK (PSU normal) Yellow = no node power or PSU is not inserted completely Red for Fail
1 GbE LAN LEDs	Activity = green flashing, Link = solid green

LED	Function
1 GbE dedicated IPMI	Left LED green for 100 Mbps, Left amber for 1 Gbps, Right yellow flashing for activity
<i>i</i> Unit identification LED	Blinking blue = UUID has been activated.

For LED states for add-on NICs, see [LED Meanings for Network Cards](#) on page 34.

LED Meanings for Network Cards

Descriptions of LEDs for supported NICs.

Different NIC manufacturers use different LED colors and blink states. Not all NICs are supported for every Nutanix platform. See the System Specifications for your platform to verify which NICs are supported.

Table 24: On-Board Ports

NIC	Link (LNK) LED	Activity (ACT) LED
1 GbE dedicated IPMI	Green: 100 Mbps Yellow: 1 Gbps	Blinking yellow: activity
1 GbE shared IPMI	Green: 1 Gbps Yellow: 100 Mbps	Blinking yellow: activity
<i>i</i> Unit identification LED	Blinking blue: UUID has been activated.	

Table 25: SuperMicro NICs

NIC	Link (LNK) LED	Activity (ACT) LED
Dual-port 1 GbE	Green: 100 Mbps Yellow: 1Gb/s OFF: 10Mb/s or No Connection	Blinking yellow: activity
Dual-port 10G SFP+	Green: 10 Gb Yellow: 1 Gb	Blinking green: activity

Table 26: Silicom NICs

NIC	Link (LNK) LED	Activity (ACT) LED
Dual-port 10G SFP+	Green: all speeds	Solid green: idle Blinking green: activity



NIC	Link (LNK) LED	Activity (ACT) LED
Quad-port 10G SFP+	Blue: 10 Gb Yellow: 1 Gb	Solid green: idle Blinking green: activity
Dual-port 10G BaseT	Yellow: 1Gb/s Green: 10Gb/s	Blinking green: activity

Table 27: Mellanox NICs

NIC	Link (LNK) LED	Activity (ACT) LED
Dual-port 10G SFP+ ConnectX-3 Pro	Green: 10Gb speed with no traffic Blinking yellow: 10Gb speed with traffic Not illuminated: no connection	Blinking yellow and green: activity
Dual-port 40G SFP+ ConnectX-3 Pro	Solid green: good link	Blinking yellow: activity Not illuminated: no activity
Dual-port 10G SFP28 ConnectX-4 Lx	Solid yellow: good link Blinking yellow: physical problem with link	Solid green: valid link with no traffic Blinking green: valid link with active traffic
Dual-port 25G SFP28 ConnectX-4 Lx	Solid yellow: good link Blinking yellow: physical problem with link	Solid green: valid link with no traffic Blinking green: valid link with active traffic

Regulatory Models

Regulatory model number	Includes SKUs
NX-1020	NX-1320, NX-1420, NX-1x65S
NX-2x00	
NX-2x50	
NX-3x00	
NX-3x50	NX-3x51, NX-1x50, NX-3x60, NX-3x61
NX-4170	
NX-6000	NX-6x50, NX-6x70, NX-6x20, NX-6x35C, NX-6x60, NX-6x80, NX-9x40



Regulatory model number	Includes SKUs
NX-7110	
NX-8150	
NXS2U4NS24G400	NX-3x60-G4, NX-9x60-G4
NXS2U2NL12G400	NX-6x35-G4, NX-8x35-G4
NXS1U1NLO4G410	NX-3175-G4
NXS2U4NL12G400	NX-1x65-G4
NXS2U1NS24G400	NX-8150-G4
NXS2U1NLO6G410	NX-3155G-G4

x stands for number of nodes

Part Number: 760-0004-0001 Rev. A

Publication Date: 2021-05-12T23:51:10+05:30

Power Supply Unit (PSU) Redundancy and Node Configuration (G4 Platforms)

Note: Nutanix recommends that you carefully plan your AC power source needs, especially in cases where the cluster consists of mixed models.

Nutanix recommends that you use 180-240V AC power source to secure PSU redundancy. However, according to the table below and depending on the number of nodes in the chassis, some NX Series platforms can work with redundant 100-210V AC power supply units.

NX-1175S-G5 platforms that shipped before June 2018 contain only one power supply and so are never redundant. NX-1175S-G5 platforms that shipped in or after June 2018 contain two power supplies and are redundant.

Table 28: PSU Redundancy and Node Configuration

Nutanix Model	DIMM or GPU Configuration per Node	Number of Nodes	Redundancy at 110V	Redundancy at 208v
NX-1065-G4	256GB	1 to 2	YES	YES
		3 to 4	NO	YES
NX-3060-G4	256GB	1 to 2	YES	YES
		3 to 4	NO	YES
NX-3155G-G4	1 GPU	1	NO	YES
	2 GPU	1	NO	YES
	3 GPU	1	NO	YES



Nutanix Model	DIMM or GPU Configuration per Node	Number of Nodes	Redundancy at 110V	Redundancy at 208v
NX-3175-G4	No GPU	1	YES	YES
	1 GPU	1	NO	YES
NX-6035-G4	256GB	1 to 2	YES	YES
NX-8035-G4	256GB	1 to 2	YES	YES
NX-8150-G4	384 GB	1	YES	YES
NX-9060-G4	256GB	1 to 2	YES	YES
		3 to 4	NO	YES

Nutanix DMI Information

Format for Nutanix DMI strings.

VMware reads model information from the direct media interface (DMI) table.

For platforms with Intel Broadwell CPUs, Nutanix provides model information to the DMI table in the following format:

NX-motherboard_idNIC_id-HBA_id-G5

motherboard-id has the following options:

Table 29:

Argument	Option
T	X10DRT motherboard
U	X10DRU motherboard
W	X10-SRW-F motherboard

NIC_id has the following options:

Table 30:

Argument	Option
00	uses on-board NIC
D1	dual-port 1G NIC
Q1	quad-port 1G NIC
DT	dual-port 10GBaseT NIC
QT	quad-port 10GBaseT NIC
DS	dual-port SFP+ NIC
QS	quad-port SFP+ NIC



HBA_id specifies the number of nodes and type of HBA controller. For example:

Table 31:

Argument	Option
1NL3	Single-node LSI3008
2NL3	2-node LSI3008
4NL3	4-node LSI3008

Table 32: Examples

DMI string	Explanation	Nutanix model
NX-T00-4NL3-G5	X10DRT motherboard with on-board NIC, 4 nodes with LSI3008 HBA controllers	<ul style="list-style-type: none"> • NX-1065-G5 • NX-1065S-G5 • NX-3060-G5 • SX-1065-G5
NX-T00-2NL3-G5	X10DRT motherboard with on-board NIC, 2 nodes with LSI3008 HBA controllers	<ul style="list-style-type: none"> • NX-6035-G5 • NX-6035C-G5 • NX-8035-G5 • NX-9030-G5
NX-UDS-1NL3-G5	X10DRU motherboard, add-on dual-port SFP+ NIC, single-node with LSI3008 HBA controller	NX-3175-G5
NX-UDT-1NL3-G5	X10DRU motherboard, add-on dual-port 10GBaseT NIC, single-node with LSI3008 HBA controller	NX-8150-G5
NX-UQ1-1NL3-G5	X10DRU motherboard, add-on quad-port 1G NIC, single-node with LSI3008 HBA controller	<ul style="list-style-type: none"> • NX-1155-G5 • NX-3155G-G5 • NX-6155-G5
NX-W00-1NL3-G5	X10-SRW-F motherboard with on-board NIC, single-node with LSI3008 HBA controller	NX-1175S-G5



Block Connection in a Customer Environment

After physically installing the Nutanix block in the datacenter, you can connect the network ports to the customer's network.

- A switch that can auto-negotiate to 100 Mbps is required for the IPMI ports on all platforms.
- A 10 GbE switch that accepts SFP+ copper cables is required for most blocks.
- Nutanix recommends 10GbE connectivity for all nodes except NX-10xx. The NX-1050, NX-1065S, and NX-1065S-G5 can use a 1 GbE switch if you have eight or fewer nodes. A 10 GbE switch is required if the NX-1050 or NX-1065S is in a mixed cluster with any NX-3050, NX-3060, NX-3060-G4, NX-3175-G4, NX-6000, NX-7000, NX-8000, or NX-9000 series. (The NX-1065S must have both a 10 GbE NIC and the Intel Xeon E5-2680v2 10-core Ivy Bridge CPU @ 2.8 GHz.) (The NX-1065S-G5 does not support 10 GbE NICs.)
- The NX-1020 requires a 1 GbE switch that accepts RJ45 cables. The NX-1020 can not be connected in a mixed cluster with other Nutanix blocks.
- Nutanix supports 10GbE over twisted-pair (10G-Base-T) for the NX-8000 platform only. If you require full speed connections for 10 GBase-T, you must use Cat 6 cables.
- The 10GbE NIC ports used on Nutanix nodes are passive. The maximum supported Twinax cable length is 5 meters, per SFP+ specifications. For longer runs fiber cabling is required.
- Nutanix offers an SFP-10G-SR adapter to convert from SFP+ Twinax to optical. This allows a switch with a 10GbE optical port to maintain the 10GbE link speed on an optical cable.
- Nutanix does not recommend the use of Fabric Extenders (FEX) or similar technologies for production use cases. While initial, low-load implementations might run smoothly with such technologies, poor performance, VM lockups, and other issues might occur as implementations scale upward (see Knowledge Base article [KB1612](#)). Nutanix recommends the use of 10Gbps, line-rate, non-blocking switches with larger buffers for production workloads.

Tip: If you are configuring a cluster with multiple blocks, perform the following procedure on all blocks before moving on to cluster configuration.

Connecting the Nutanix Block

Before you begin

This procedure requires the following components:

- One Nutanix block (installed in a rack but not yet connected to a power source)
- Customer networking hardware, including 10 GbE ports (SFP+ copper) and 1 GbE ports
- One 10 GbE SFP+ cable for each node (provided). (For NX-1020, you must provide your own RJ45 cables)
- One to three RJ45 cables for each node (customer provided)
- Two power cables (provided)

CAUTION: Note the orientation of the ports on the Nutanix block when you are cabling the ports.



Procedure

1. Connect the 10/100 or 10/100/1000 IPMI port of each node onto the customer switch with RJ45 cables.
The switch that the IPMI ports connect to must be capable of auto-negotiation to 100 Mbps.
2. Connect one or more 10 GbE ports of each node to the customer switch with the SFP+ cables. If you are using 10GBase-T, optimal resiliency and performance require CAT 6 cables. (If you are connecting an NX-1000 series that only has 1 Gbe, you only require a 1 GbE switch.)
3. (Optional) Connect one or more 1 GbE or 10 GBaseT ports of each node to the customer switch with RJ45 cables. (For optimal 10GBaseT resiliency and performance use Cat 6 cables). (For the NX-1020, both ports must be connected using a 1 GbE switch.)
4. Connect both power supplies to a grounded, 208V power source (208V to 240V).

Tip: If you are configuring the block in a temporary location before installing it on a rack, the input can be 120V. After moving the block into the datacenter, make sure that the block is connected to a 208V to 240V power source, which is required for power supply redundancy.

5. Confirm that the link indicator light next to each IPMI port is illuminated.
6. Turn on all nodes by pressing the power button on the front of each node (the top button).
The top power LED illuminates and the fans are noticeably louder for approximately 2 minutes.

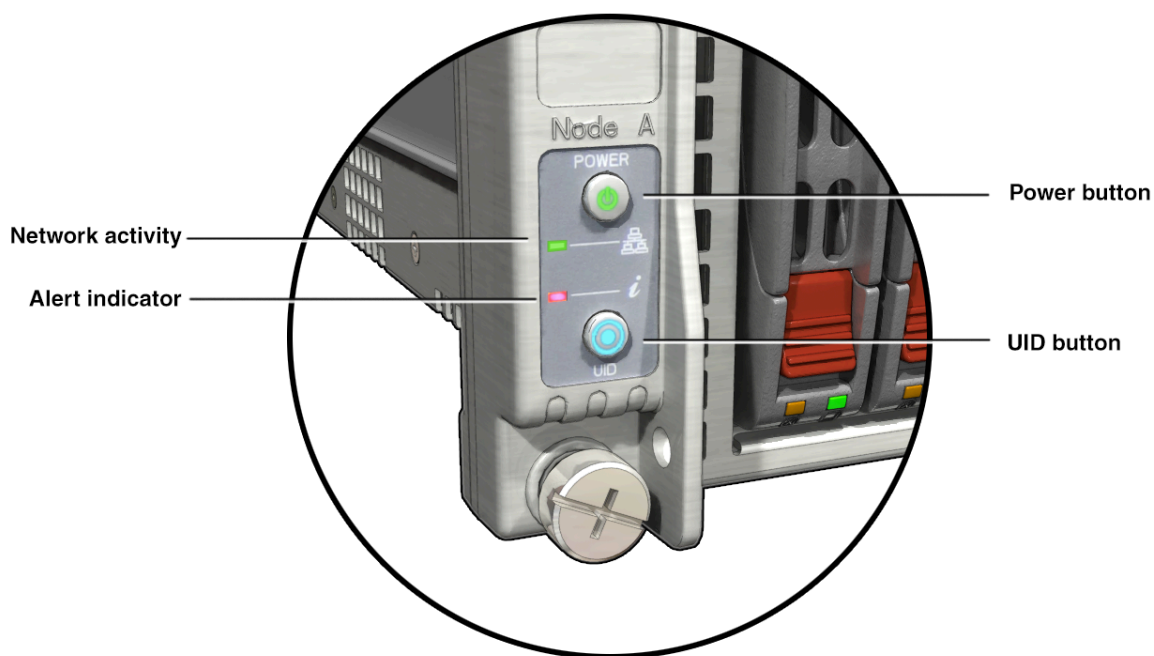

Figure 26: Control panel with power button

MEMORY CONFIGURATIONS

Supported Memory Configurations (G4 Platforms)

DIMM installation order for all Nutanix G4 platforms. When removing, replacing, or adding memory, use the rules and guidelines in this topic.

DIMM Restrictions for G4 Platforms

Each G4 node must contain only DIMMs from the same manufacturer and of the same type, speed, and capacity.

DIMM Performance

Memory performance is most efficient with a configuration where every memory channel contains the same number of DIMMs. Nutanix supports other configurations, but be aware that these configurations result in lower performance.

Memory Installation Order for All Platforms

A memory channel is a group of DIMM slots.

Each CPU is associated with four memory channels. Memory channels contain either two or three DIMM slots, depending on the motherboard.

Two DIMMs per channel (2DPC) memory channels have one blue slot and one black slot each, as shown in the following figure.

Table 33: Platforms with Two DIMMs per Channel (2DPC)

NX-1065-G4	NX-8035-G4
NX-3060-G4	NX-9060-G4
NX-6035-G4	

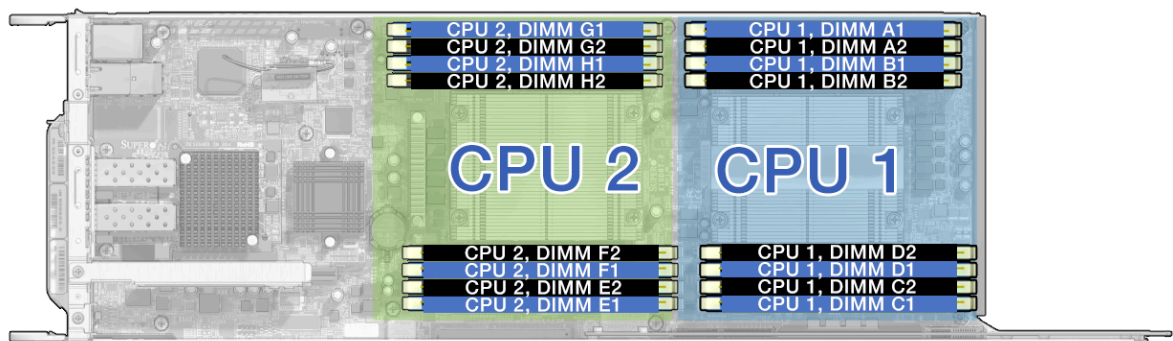

Figure 27: Multi-node Motherboard with 2DPC Memory Channels

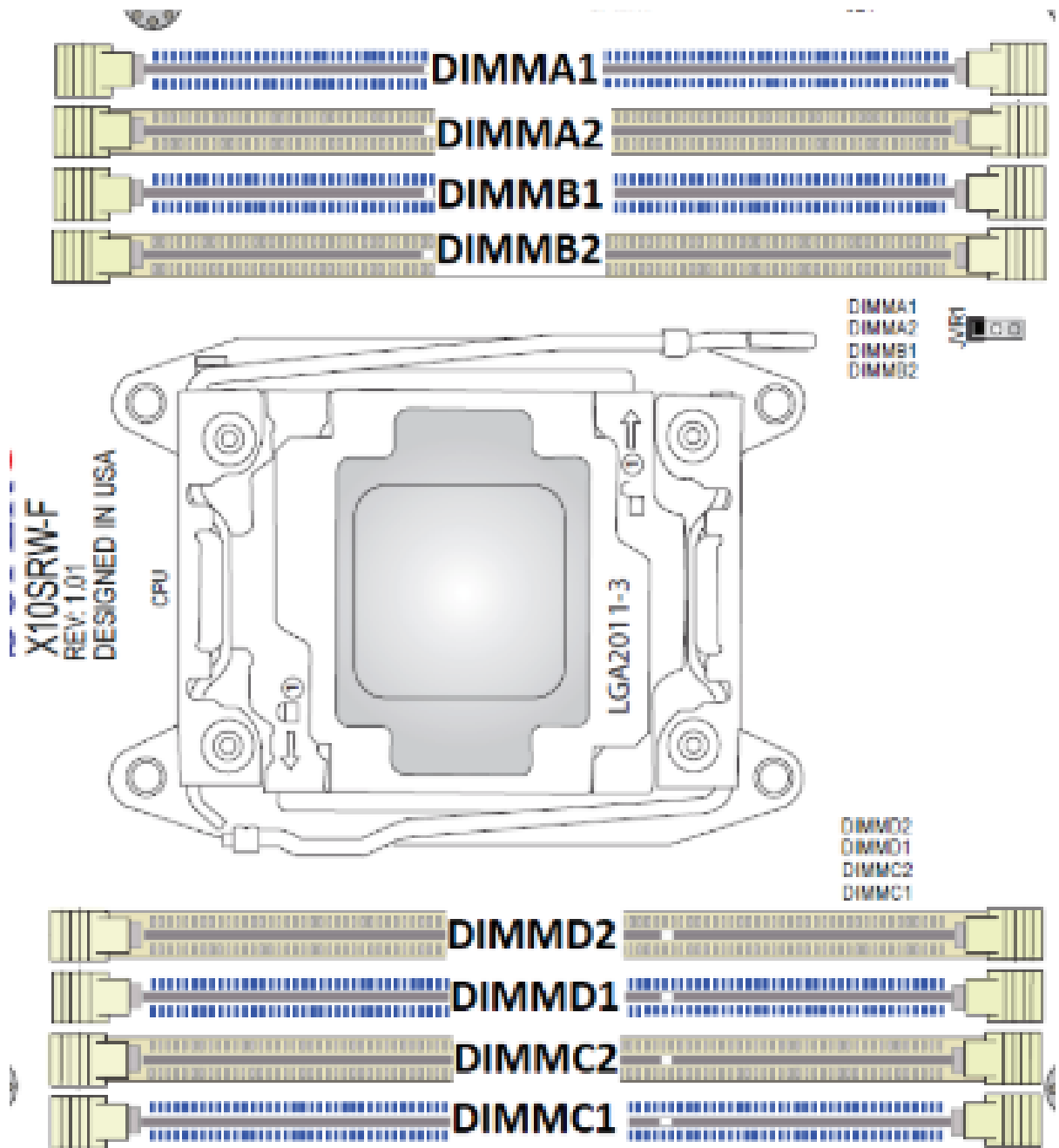

Figure 28: Single-socket Motherboard with 2DPC Memory Channels

Table 34: Platforms with Three DIMMs Per Channel (3DPC)

NX-3155G-G4	NX-8150-G4
NX-3175-G4	

Three DIMMs per channel (3DPC) memory channels have one blue slot and two black slots each, as shown in the following figure.

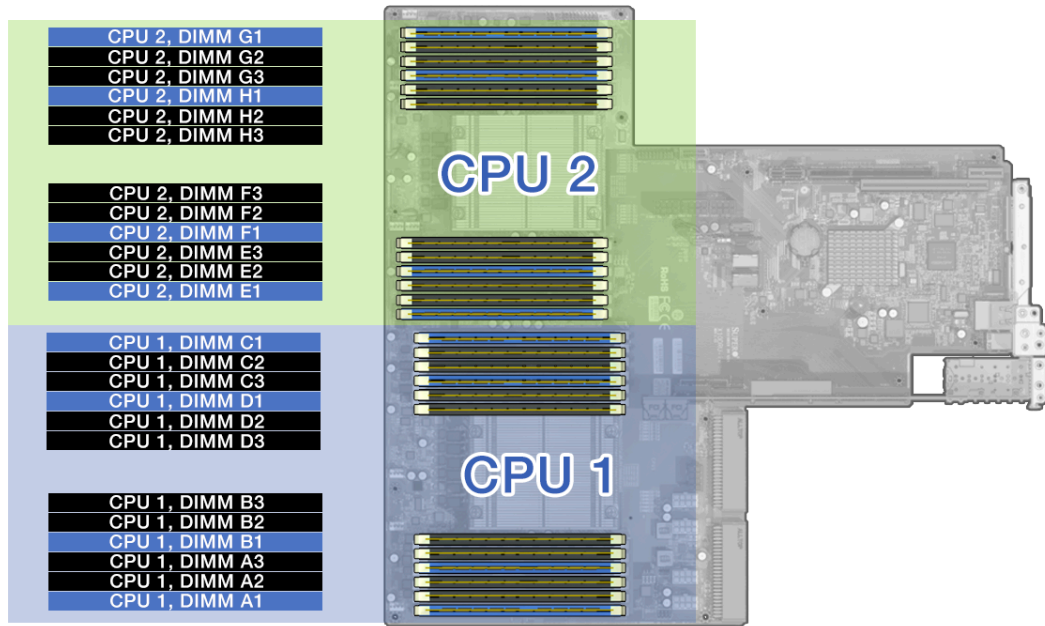

Figure 29: Motherboard with 3DPC Memory Channels

Note: DIMM slots on the motherboard are most commonly labeled as A1, A2, and so on. However, some software tools report DIMM slot labels in a different format, such as 1A, 2A, or CPU1, CPU2, or DIMM1, DIMM2.

Number of CPUs	Number of DIMMs	Slots to use
1	3 (unbalanced)	A1, B1, C1 (blue slots)
1	4	A1, B1, C1, D1 (blue slots)
1	6 (unbalanced)	A1, B1, C1, D1 (blue slots) A2, B2 (black slots)
1	8	Fill all slots.
2	4 (unbalanced)	A1, B1, E1, F1 (blue slots)
2	6 (unbalanced)	A1, B1, C1, E1, F1, G1 (blue slots)
2	8	A1, B1, C1, D1, E1, F1, G1, H1 (blue slots)
2	12 (unbalanced)	A1, B1, C1, D1, E1, F1, G1, H1 (blue slots) A2, B2, E2, F2 (black slots)
2	16	A1, B1, C1, D1, E1, F1, G1, H1 (blue slots) A2, B2, C2, D2, E2, F2, G2, H2 (black slots)

Number of CPUs	Number of DIMMs	Slots to use
2	20 (unbalanced)	A1, B1, C1, D1, E1, F1, G1, H1 (blue slots) A2, B2, C2, D2, E2, F2, G2, H2 (black slots) A3, B3, E3, F3 (black slots)
2	24	Fill all slots.

DIMM Slot Examples

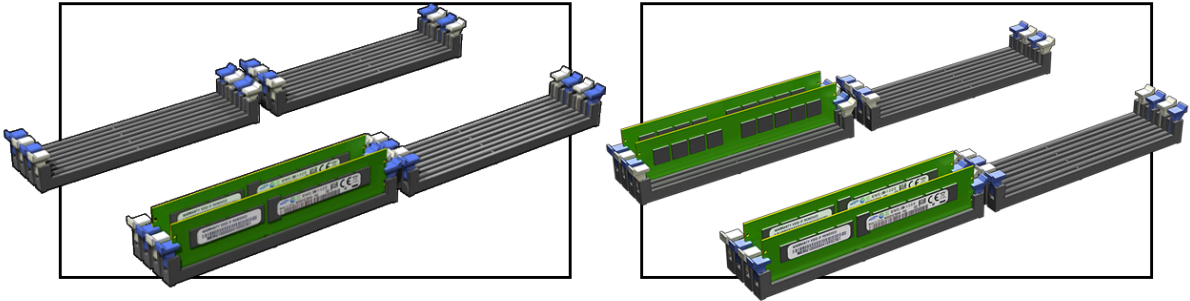

Figure 30: Single-Socket CPU DIMM Configurations

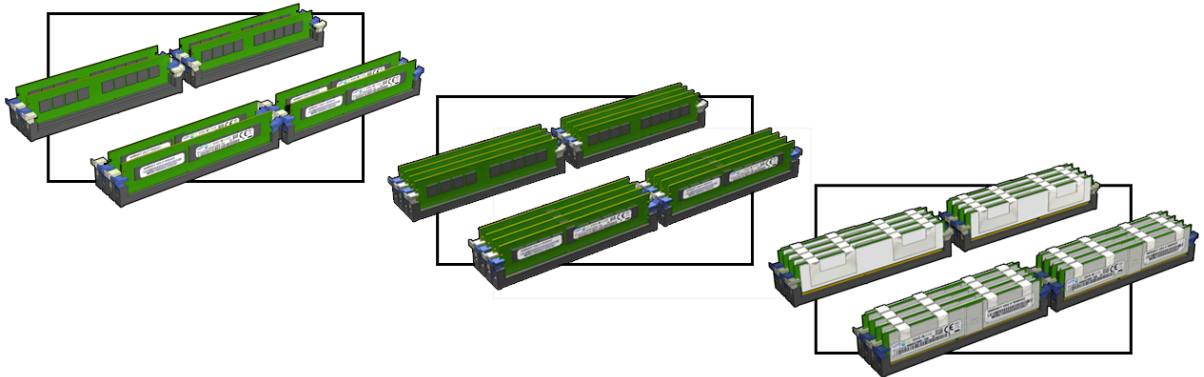

Figure 31: Balanced 2DPC DIMM Configurations

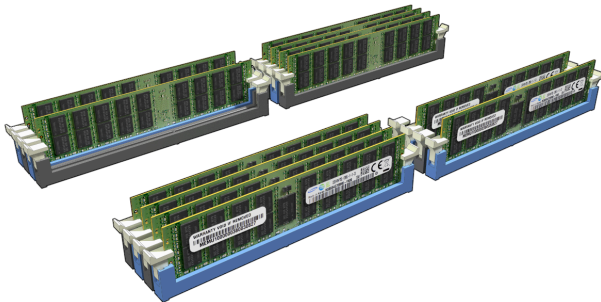

Figure 32: Unbalanced 2DPC DIMM Configurations

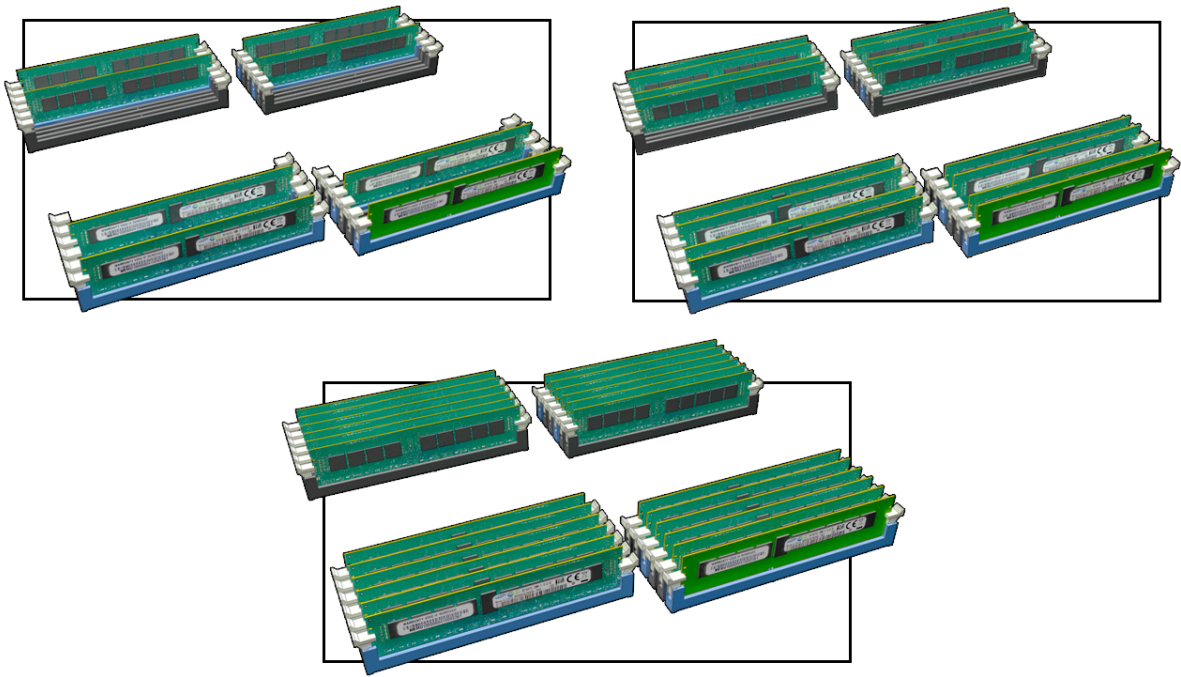

Figure 33: 3DPC DIMM Configurations

DIMM and CPU Performance

Table 35: CPU and DIMM Performance for Intel Haswell CPUs with BIOS 1.0c (G4U-1.0)

DIMM Information	DIMM Speed with Low Speed CPUs: E5-2620v3			DIMM speed with High Speed CPUs: E5-2660v3, E5-2680v3,		
	Number of DIMMs per channel					
	1	2	3	1	2	3
16 GB RDIMM	1866	1866	1866	2133	2133	1866
32 GB LRDIMM	1866	1866	1866	2133	2133	1866



COPYRIGHT

Copyright 2021 Nutanix, Inc.

Nutanix, Inc.
1740 Technology Drive, Suite 150
San Jose, CA 95110

All rights reserved. This product is protected by U.S. and international copyright and intellectual property laws. Nutanix and the Nutanix logo are registered trademarks of Nutanix, Inc. in the United States and/or other jurisdictions. All other brand and product names mentioned herein are for identification purposes only and may be trademarks of their respective holders.

License

The provision of this software to you does not grant any licenses or other rights under any Microsoft patents with respect to anything other than the file server implementation portion of the binaries for this software, including no licenses or any other rights in any hardware or any devices or software that are used to communicate with or in connection with this software.

Conventions

Convention	Description
<i>variable_value</i>	The action depends on a value that is unique to your environment.
<code>ncli> command</code>	The commands are executed in the Nutanix nCLI.
<code>user@host\$ command</code>	The commands are executed as a non-privileged user (such as nutanix) in the system shell.
<code>root@host# command</code>	The commands are executed as the root user in the vSphere or Acropolis host shell.
<code>> command</code>	The commands are executed in the Hyper-V host shell.
<code>output</code>	The information is displayed as output from a command or in a log file.

Version

Last modified: May 12, 2021 (2021-05-12T23:51:10+05:30)