

---

PageWriter XL Cardiographs  
M1700A, M1701A, and M1702A  
Mobile Cart M1705A  
Telecommunications Package M1706A

## **Service Manual**

Including information on: M1754A Signal  
Averaged ECG (SAECG), M1755A A.02.00, and  
A.03.00 Software, M1756A FAX Modem, and  
M1790A Vectorcardiography (VCG)



HP Part No. M1700-91909  
Printed in USA November 1992

Edition 6  
E1192

---

## Notice

The information in this document may change without notice.

Hewlett-Packard makes no warranty of any kind with regard to this material, including, but not limited to, the implied warranties of merchantability and fitness for a particular purpose. Hewlett-Packard shall not be liable for errors herein or for incidental or consequential damages in connection with the furnishing, performance or use of this material.

This document contains or refers to proprietary information which is protected by copyright. All rights are reserved. Copying or other reproduction of this document without prior written permission of Hewlett-Packard Company is prohibited.

## Responsibility of the Manufacturer

Hewlett-Packard only considers itself responsible for any effects on safety, reliability and performance of the equipment if all the following are true:

- Assembly operations, extensions, re-adjustments, modifications or repairs are done by persons authorized by Hewlett-Packard.
- The electrical installation of the relevant room complies with the IEC requirements (IEC regulated countries only).
- The instrument is used according to the instructions for use presented in this manual.

## Warranty

Hewlett-Packard warrants this medical product against defects in materials and workmanship for a period of:

1. One year on instrument.
2. *Lifetime on M1700A and M1701A patient module (remote front end). Lifetime is defined as the end of the product's support life. This is ten years after the cardiograph is removed from Hewlett-Packard's price list.*
3. One year on M1702A patient module (remote front end).
4. All other accessories including cables, battery, and consumables are under standard, 90-day warranty.

If Hewlett-Packard receives notice of such defects during the warranty period, Hewlett-Packard shall, at its option, either repair or replace hardware products which prove to be defective.

Hewlett-Packard software and firmware products that are designated by Hewlett-Packard for use with a hardware product, when properly installed on that hardware product, are warranted not to fail to execute their programming instructions due to defects during the warranty period. Hewlett-Packard shall repair or replace software media and firmware that do not execute their programming instructions due to such defects. Hewlett-Packard does not warrant that the operation of the software, firmware, or hardware shall be uninterrupted or error free.

If Hewlett-Packard is unable, within a reasonable time, to repair or replace any product to a condition as warranted, Buyer shall be entitled to a refund of the purchase upon return of the product to Hewlett-Packard.

### **Limitation of Warranty**

The foregoing warranty shall not apply to defects resulting from any of the following:

1. Improper or inadequate maintenance by Buyer.
2. Buyer-supplied software or interfacing.
3. Unauthorized modification or misuse.
4. Operation outside of the environmental specifications for the product.
5. Improper site preparation and maintenance.

THE WARRANTY SET FORTH ABOVE IS EXCLUSIVE AND NO OTHER WARRANTY, WHETHER WRITTEN OR ORAL, IS EXPRESSED OR IMPLIED. HEWLETT-PACKARD SPECIFICALLY DISCLAIMS THE IMPLIED WARRANTIES OF MERCHANTABILITY AND FITNESS FOR A PARTICULAR PURPOSE.

---

## Printing History





May 1990	Edition 1
May 1991	Edition 2
July 1991	Edition 3
February 1992	Edition 4
March 1992	Edition 5
November 1992	Edition 6

---

## Safety Summary

### Safety Symbols Marked on the Cardiograph

The following symbols are used on the cardiograph or the cart.

-  Caution - See operating instructions.
-  Type CF, external defibrillation protected.
-  Alternating current.
-  Equipotential (this is on the ground lug).
-  The maximum weight that the cart can hold.

Please see chapter 4, "Performance Verification and Maintenance," for safety requirements that apply to the cardiograph.

### Conventions Used in This Manual

Warning



---

Warning statements describe conditions or actions that can result in personal injury or loss of life.

---

Caution



---

Caution statements describe conditions or actions that can result in damage to the equipment or software.

---

Note



---

Notes contain additional information on cardiograph usage.

---

Softkey

represents the temporary key labels that appear on the display.



represents keys on the front panel.

---

## Preface

This manual contains service information for the Hewlett-Packard M1700A PageWriter XLi, M1701A PageWriter XLs, and M1702A PageWriter XLe cardiographs. The information and procedures in this manual apply to all models unless otherwise specified.

This manual is organized as follows:

**Chapter 1—Introduction.** Contains a general description of the cardiographs, lists of technical specifications, and lists of accessories and options.

**Chapter 2—Installation and Configuration.** Summarizes the cardiograph installation and explains how to configure the cardiograph for specific customer requirements.

**Chapter 3—Operation.** Summarizes how to operate the cardiograph.

**Chapter 4—Performance Verification and Maintenance.** Explains how to check the cardiograph's performance using built-in self-tests, and lists maintenance procedures and safety requirements that apply to the cardiograph.

**Chapter 5—Theory of Operation.** Provides an overview of how the cardiograph works and describes the operation of the major subassemblies.

**Chapter 6—Troubleshooting.** Contains procedures and error codes to aid the service person in localizing faults to a replaceable subassembly.

**Chapter 7—Removal and Replacement.** Contains procedures for removing and replacing each of the cardiograph's major subassemblies.

**Chapter 8—Parts List.** Lists part numbers for the cardiograph's replaceable parts, and provides assembly drawings.

**Appendix A—Connector Pin Assignments.** Identifies and defines the signals assigned to the subassembly interconnections.

**Index.**

# Contents

---

1. Introduction	
PageWriter XL Cardiographs . . . . .	1-1
M1705A Cart . . . . .	1-3
M1706A Telecommunications Package . . . . .	1-4
M1755A A.03.XX Software . . . . .	1-4
A.02.XX Software . . . . .	1-4
A.01.XX Software . . . . .	1-4
Inquiries . . . . .	1-4
Specification Data . . . . .	1-5
Options and Accessories . . . . .	1-9
PageWriter XLi, XLs and XLe Cardiographs . . . . .	1-9
Country Options . . . . .	1-9
Delete Options . . . . .	1-9
Cable Options . . . . .	1-9
Supplies/Accessories Options . . . . .	1-10
Substitute Options . . . . .	1-10
Documentation Options . . . . .	1-10
Standard Accessories Supplied . . . . .	1-10
M1703A PageWriter XLi Upgrade Kits . . . . .	1-11
Options . . . . .	1-11
M1704A PageWriter XLs Upgrade Kits . . . . .	1-11
Options . . . . .	1-11
M1706A Telecommunications Package . . . . .	1-11
Options . . . . .	1-11
M1753A PageWriter XLe Upgrade Kit . . . . .	1-12
Options . . . . .	1-12
M1754A PageWriter XLi Signal Averaged ECG System . . . . .	1-12
Documentation Options . . . . .	1-12
M1755A PageWriter XLi Upgrade Kit . . . . .	1-12
M1756A PageWriter XLi Direct Digital ECG Fax Modems . . . . .	1-12
Options . . . . .	1-12
M1788A Extra Patient Module . . . . .	1-13
Options . . . . .	1-13
Substitute Options . . . . .	1-13
M1790A PageWriter XLi Vectorcardiography . . . . .	1-13
Country Option Configurations . . . . .	1-14

2. Installation and Configuration	
Installation	2-1
Installing the Cardiograph and Modems on the Cart	2-2
Installing the M1756A Fax Modem	2-2
Printing an ECG on an HP LaserJet Printer	2-4
Setting up the LaserJet Printer	2-5
Configuring the Cardiograph to Print ECGs on the HP LaserJet	2-6
Connecting the Patient Module	2-7
Changing the Line Voltage Setting	2-8
Changing the Line Fuses	2-10
Installing the Battery	2-11
Installing the Software on the M1700 & M1701A	2-13
Installing the Software on the M1702A	2-14
Loading the Paper	2-14
Setting the Date and Time	2-16
Configuration	2-17
Configuring the M1700A and M1701A	2-17
Configuring the M1702A	2-18
Selecting Configuration Parameters	2-19
Global Configuration	2-20
Interpretation Parameters	2-24
Power-on Application (M1755A A.02.XX and Higher Software Only)	2-24
Line Frequency	2-24
Custom Lead Groups	2-25
AutoCopy	2-25
ECG Management Parameters	2-26
Battery Timeout	2-26
Password	2-26
ID Configuration	2-27
Transmit Configuration	2-28
Transmit	2-28
Entering the Phone Number	2-29
Receive	2-30
AutoDial	2-30
LaserJet Printer Configuration (A.03.XX Software Only)	2-31
Configuration Files	2-31
Store	2-31
Print	2-32

<b>3. Operation</b>	
The Keyboard and Front Panel . . . . .	3-2
Other Operating Controls . . . . .	3-3
Choosing a Report Format . . . . .	3-4
Main Functions . . . . .	3-9
Transmit (M1700A Only) . . . . .	3-10
Store (M1700A & M1701A only) . . . . .	3-11
Config . . . . .	3-11
CheckDisk (M1700A & M1701A only) . . . . .	3-11
A.01.XX Software . . . . .	3-11
A.02.XX and Higher Software . . . . .	3-11
Files (M1700A & M1701A only) . . . . .	3-12
The Selection Display (M1700A & M1701A only) . . . . .	3-14
Selection Display Menu, Part 1 . . . . .	3-14
Selection Display Menu, Part 2 . . . . .	3-14
Recording an ECG . . . . .	3-15
Using the Patient Module Start Button . . . . .	3-16
Preview Plus (A.02.XX and Higher Software Only) . . . . .	3-16
Using Preview Plus . . . . .	3-16
<b>4. Performance Verification and Maintenance</b>	
Introduction . . . . .	4-1
Performance Verification . . . . .	4-1
Visual Inspection . . . . .	4-1
Extended Self-test . . . . .	4-2
Patient Module and Cable Test . . . . .	4-3
CPU Assembly Test . . . . .	4-3
Printer Test . . . . .	4-4
Disk Drive Test (M1700A and M1701A only) . . . . .	4-4
Preview Display Test (M1700A Only) . . . . .	4-5
Keyboard Display Test . . . . .	4-6
Modem Test (M1700A Only) . . . . .	4-6
All Tests . . . . .	4-7
Printing the Error Log . . . . .	4-7
ECG Simulation . . . . .	4-8
Preventive Maintenance . . . . .	4-9
Care and Cleaning . . . . .	4-10
Cleaning the Cardiograph and Patient Module . . . . .	4-10
Cleaning the Keyboard . . . . .	4-10
Cleaning the Printhead and Paper Sensor . . . . .	4-11
Maintaining the Flexible Disk Drive . . . . .	4-12
Cleaning the Electrodes, Leadwires, and Patient Data Cable . . . . .	4-13
Safety Tests . . . . .	4-13
PageWriter XL Performance Verification Checklist . . . . .	4-14
Visual Inspection . . . . .	4-14
Extended Self-test . . . . .	4-14
ECG Simulation . . . . .	4-15
Comments: . . . . .	4-15

5. Theory of Operation	
Operational Overview	5-1
ECG Data Path	5-1
Power-on and Power-off Sequences	5-2
Power-on	5-2
Power-off	5-2
Circuit Descriptions	5-4
The Standard Patient Module	5-6
CPU Assembly	5-8
CPU	5-8
System Memory	5-10
ROM	5-10
I/O Control	5-12
The FGA	5-12
Serial Communications	5-14
Digital Signal Processor	5-14
System Expansion Connector	5-15
Disk Drive (M1700A and M1701A only)	5-15
Power Supply	5-16
VMAIN and VIN	5-16
Battery Charger and Battery Sensor	5-18
Battery Operation and Condition	5-18
5 Volt Regulator	5-19
+5 Overvoltage/ Undervoltage Sensor	5-19
Printer Switch	5-20
Battery Switch	5-20
ACON Detector	5-20
+5 Backup Supply and Low Battery Disconnect	5-21
+5 to Backup Switchover	5-21
Patient Module Voltage Regulator	5-21
The Keyboard and Keyboard Display	5-22
Printer	5-22
Printer Gate Array	5-22
Printer RAM	5-22
Motor Driver	5-22
ADC (Analog-to-Digital Converter)	5-23
Thermal Printhead	5-23
The Preview Display	5-24
Preview Logic Board	5-25
Preview Display Power Supply Board	5-26
VLCD Supply	5-27
VCFL Supply	5-27
Preview Screen	5-27

<b>6. Troubleshooting</b>	
Introduction . . . . .	6-1
Maintenance Philosophy . . . . .	6-1
Test Equipment . . . . .	6-1
The Error Log . . . . .	6-2
Clearing the Log . . . . .	6-2
Errors . . . . .	6-3
Using Extended Self-test in Troubleshooting . . . . .	6-4
Troubleshooting Tables . . . . .	6-5
Testing the Power Supply . . . . .	6-22
<b>7. Removal and Replacement</b>	
Introduction . . . . .	7-1
Tool Requirements . . . . .	7-2
The Battery . . . . .	7-2
Removing the Battery . . . . .	7-2
Replacing the Battery . . . . .	7-4
The Keyboard and the User Interface Assembly . . . . .	7-5
The Keyboard . . . . .	7-5
The User Interface Assembly . . . . .	7-5
Removing the User Interface Assembly . . . . .	7-5
Replacing the User Interface Assembly . . . . .	7-6
The Printer Drive Assembly . . . . .	7-7
Removing the Printer Drive Assembly . . . . .	7-7
PageWriters with Serial Number Prefix 3208A or Later . . . . .	7-7
PageWriters with Serial Number Prefix Prior to 3208A . . . . .	7-9
Replacing the Printer Drive Assembly . . . . .	7-11
The Preview Screen Assembly . . . . .	7-12
Removing the Preview Screen Assembly . . . . .	7-12
PageWriters with Serial Number Prefix 3208A or Later . . . . .	7-12
Removing the Entire Preview Screen Assembly . . . . .	7-12
Disassembling the Preview Screen Assembly . . . . .	7-13
PageWriters with Serial Number Prefix Prior to 3208A . . . . .	7-15
Removing the Entire Preview Screen Assembly . . . . .	7-15
Disassembling the Preview Screen Assembly . . . . .	7-15
Replacing the Preview Screen Assembly . . . . .	7-17
The Top Cover Assembly . . . . .	7-17
Opening and Removing the Top Cover Assembly . . . . .	7-17
PageWriters with Serial Number Prefix 3208A or Later . . . . .	7-17
PageWriters with Serial Number Prefix Prior to 3208A . . . . .	7-19
Reinstalling the Top Cover Assembly . . . . .	7-20
The Printhead Assembly . . . . .	7-20
Removing the Printhead Assembly . . . . .	7-20
PageWriters with Serial Number Prefix 3208A or Later . . . . .	7-20

PageWriters with Serial Number Prefix Prior to 3208A . . . . .	7-21
Removing the Optical Paper Sensor . . . . .	7-23
Replacing the Printhead Assembly . . . . .	7-23
The Preview Logic Board . . . . .	7-25
Removing the Preview Logic Board . . . . .	7-25
PageWriters with Serial Number Prefix 3208A or Later . . . . .	7-25
PageWriters with Serial Number Prefix Prior to 3208A . . . . .	7-27
Replacing the Preview Logic Board . . . . .	7-28
The CPU Assembly . . . . .	7-29
Removing the CPU Assembly . . . . .	7-29
Replacing the CPU Assembly . . . . .	7-31
The Disk Drive (M1700A and M1701A only) . . . . .	7-31
Replacing the Disk Drive . . . . .	7-32
<b>8. Parts Lists</b>	
Introduction . . . . .	8-1
Ordering Information . . . . .	8-1
Calling for Assistance . . . . .	8-1
United States of America . . . . .	8-1
Canada . . . . .	8-1
<b>A. Connector Pin Assignments</b>	
CPU Assembly Connectors . . . . .	A-1
Preview Display Connectors . . . . .	A-11
<b>B. M1754A Signal Averaged ECG (SAECG) System</b>	
Introduction . . . . .	B-1
Installation and Configuration . . . . .	B-2
Connecting the Patient Module . . . . .	B-2
Installing the SAECG Software . . . . .	B-3
SAECG Configuration (A.02.XX and higher Software Only) . . . . .	B-4
Acquisition Fields . . . . .	B-4
Measurement Fields . . . . .	B-5
Operation . . . . .	B-6
SAECG (M1754A Only) . . . . .	B-6
Using SAECG . . . . .	B-7
Editing and Printing a Stored SAECG . . . . .	B-10
Deleting a Stored SAECG . . . . .	B-10
Performance Verification and Maintenance . . . . .	B-11
Extended Self-test . . . . .	B-11
Patient Module and Cable Test . . . . .	B-12
Theory of Operation . . . . .	B-13
The SAECG Patient Module . . . . .	B-13
Troubleshooting . . . . .	B-15
Parts List . . . . .	B-16

<b>C. M1756A Direct Digital ECG Fax</b>	
Introduction . . . . .	C-1
Installation and Configuration . . . . .	C-2
Operation . . . . .	C-3
Transmitting ECGs by Fax . . . . .	C-3
Transmitting More than One ECG . . . . .	C-4
Receiving ECGs . . . . .	C-4
Performance Verification and Maintenance . . . . .	C-5
Extended Self-test . . . . .	C-5
Fax Modem Test (M1700A Only) . . . . .	C-6
Troubleshooting . . . . .	C-7
Parts List . . . . .	C-8
<b>D. Vectorcardiography M1790A</b>	
Introduction . . . . .	D-1
Installation and Configuration . . . . .	D-2
Setting Up the Patient Module . . . . .	D-2
Software Installation . . . . .	D-3
VCG Configuration (A.03.XX Software Only) . . . . .	D-3
Disabling VCG Reports . . . . .	D-4
Operation . . . . .	D-4
Recording a VCG . . . . .	D-4
Printing a Stored VCG . . . . .	D-5
Preventing the VCG Report from Printing . . . . .	D-5
The VCG Report . . . . .	D-6
VCG Report Formats . . . . .	D-7
Formats . . . . .	D-7
Manual Report Formats . . . . .	D-10
Troubleshooting . . . . .	D-10
Parts List . . . . .	D-12

**Index**

## Figures

---

1-1. M1700A PageWriter XLi Cardiograph with Preview Display. . . . .	1-2
2-1. Installing the Hayes® Modem. . . . .	2-2
2-2. Connecting the Fax Modem Cables. . . . .	2-3
2-3. Connecting the Printer Cable. . . . .	2-4
2-4. Connecting the Patient Module. . . . .	2-7
2-5. The Line Module and AC Switch. . . . .	2-8
2-6. Installing the Battery. . . . .	2-11
2-7. Fitting the Battery Holder Tab Into the Battery Slot.	2-12
2-8. Loading the Paper. . . . .	2-15
3-1. The Keyboard and Front Panel. . . . .	3-2
3-2. An Auto 3x4 ECG (3x4). . . . .	3-6
3-3. An Auto 3x4 ECG With Three Rhythm Strips (3x4, 3R). . . . .	3-7
3-4. A Manual 6-Lead ECG. . . . .	3-8
4-1. 12-Lead ECG from ECG Simulator. . . . .	4-8
4-2. Cleaning the Digital Array Printhead. . . . .	4-11
5-1. CPU Initialization Flow Chart. . . . .	5-3
5-2. Simplified System Block Diagram. . . . .	5-5
5-3. Patient Module Block Diagram. . . . .	5-7
5-4. CPU Assembly Block Diagram. . . . .	5-9
5-5. System Memory Block Diagram. . . . .	5-11
5-6. I/O Control Block Diagram. . . . .	5-13
5-7. Serial Communications Circuitry. . . . .	5-14
5-8. Digital Signal Processor Block Diagram. . . . .	5-15
5-9. The Disk Drive and its Control Circuit. . . . .	5-15
5-10. Power Supply Block Diagram. . . . .	5-17
5-11. Printer Block Diagram. . . . .	5-23
5-12. Preview Display Subassembly Connections. . . . .	5-24
5-13. Preview Logic Board Block Diagram. . . . .	5-25
5-14. Preview Display Power Supply Block Diagram. . . . .	5-27
6-1. Sample Error Log Printout. . . . .	6-3
6-2. Troubleshooting Flowchart. . . . .	6-6
6-3. Voltage Test Locations. . . . .	6-24
7-1. Opening the Battery Compartment. . . . .	7-3
7-2. Fitting the Battery Holder Tab Into the Battery Slot.	7-1
7-3. Removing the Keyboard. . . . .	7-5
7-4. User Interface Screw Locations. . . . .	7-6
7-5. Removing the Printhead Cover. . . . .	7-7
7-6. Printer Drive and Keyboard Ground Plane Screw Locations. . . . .	7-8
7-7. Removing the Printhead Cover. . . . .	7-9

7-8. Printer Drive and Keyboard Ground Plane Screw Locations. . . . .	7-10
7-9. The Printer Drive Gears. . . . .	7-11
7-10. Opening and Removing the Top Cover Assembly. . . . .	7-13
7-11. Removing the Preview Screen Assembly. . . . .	7-14
7-12. Removing the Preview Screen Assembly. . . . .	7-16
7-13. Opening and Removing the Top Cover Assembly. . . . .	7-18
7-14. Opening and Removing the Top Cover Assembly. . . . .	7-19
7-15. Removing the Printhead Cover and Printhead. . . . .	7-21
7-16. Removing the Printhead Cover and Printhead. . . . .	7-22
7-17. Printhead Resistance Selector. . . . .	7-24
7-18. Preview Logic Board Removal (Serial Number Prefix 3208A or Later). . . . .	7-26
7-19. Preview Logic Board Assembly Screw Locations. . . . .	7-28
7-20. Screw and Connector Locations on the CPU Assembly. . . . .	7-30
7-21. Disk Drive Mounting Screws. . . . .	7-32
8-1. Patient Module Diagram. . . . .	8-2
8-2. Main Assembly Exploded Diagram (Serial Number Prefix 3208A or Later). . . . .	8-4
8-3. Main Assembly Exploded Diagram (Serial Number Prefix Prior to 3208A). . . . .	8-9
8-4. Printer Assembly Diagram. . . . .	8-15
8-5. Preview Display Assembly Diagram. . . . .	8-17
8-6. Cart Exploded Diagram. . . . .	8-19
8-7. Data Communications Package Diagram. . . . .	8-21
8-8. Connections for Direct-Connect Transmission . . . . .	8-22
8-9. Cabling for Hayes Modem Transmission Only . . . . .	8-23
8-10. Cabling for Hayes Modem and Direct Connect (Quick Connect) Transmission . . . . .	8-24
8-11. Cabling for LaserJet Printing . . . . .	8-25
B-1. Connecting the Patient Module. . . . .	B-2
B-2. An SAECG Report. . . . .	B-6
B-3. A Template Screen. . . . .	B-8
B-4. SAECG Patient Module Block Diagram. . . . .	B-14
C-1. Cabling for FAX Modem Transmission Only . . . . .	C-9
C-2. Cabling for FAX Modem and Direct Connect (Quick Connect) Transmission . . . . .	C-10
D-1. The VCG Report . . . . .	D-6
D-2. VCG1: Right Sagittal, 0° to 360°. . . . .	D-7
D-3. VCG2: Left Sagittal, 0° to 360°. . . . .	D-8
D-4. VCG3: Right Sagittal, -180° to +180°. . . . .	D-8
D-5. VCG4: Left Sagittal, -180° to +180°. . . . .	D-9

## Tables

---

1-1. Physical Specifications . . . . .	1-5
1-2. Patient Module Specifications . . . . .	1-5
1-3. SAECG Patient Module Specifications . . . . .	1-6
1-4. ECG to Paper Specifications . . . . .	1-6
1-5. Power Supply and Battery Specifications . . . . .	1-7
1-6. Environmental Specifications . . . . .	1-8
1-7. Miscellaneous Specifications . . . . .	1-8
1-8. Country Option Configurations . . . . .	1-14
2-1. Line Voltage Settings . . . . .	2-9
2-2. Line Fuse Ratings for Voltage Settings . . . . .	2-9
2-3. Global Configuration Parameters . . . . .	2-20
2-4. Site Transmission Configuration . . . . .	2-29
2-5. Site Receive Configuration . . . . .	2-30
2-6. LaserJet Printer Configuration . . . . .	2-31
6-1. Power-on Errors . . . . .	6-8
6-2. Power Supply and Battery . . . . .	6-9
6-3. Patient Module and Patient Data Cable . . . . .	6-12
6-4. CPU Assembly (CPU, FGA, ROM, RAM) . . . . .	6-14
6-5. Printer . . . . .	6-15
6-6. Disk Drive (M1700A and M1701A only) . . . . .	6-17
6-7. Preview Display and Logic (M1700A) . . . . .	6-19
6-8. Keyboard and Keyboard Display (LCD) . . . . .	6-20
6-9. Transmit and Modem . . . . .	6-21
7-1. Printhead Resistance Codes . . . . .	7-23
8-1. Patient Module Parts List . . . . .	8-3
8-2. Main Assembly Parts List (Serial Number Prefix 3208A or Later) . . . . .	8-5
8-3. Main Assembly Parts List (Serial Number Prefix Prior to 3208A) . . . . .	8-10
8-4. Fastener List . . . . .	8-14
8-5. Printer Parts List . . . . .	8-16
8-6. Preview Display Assembly Parts List . . . . .	8-18
8-7. Cart Parts List . . . . .	8-20
8-8. Cart Fastener List . . . . .	8-20
8-9. Data Communications Package Parts List . . . . .	8-21
8-10. Direct Connect Cable Parts List . . . . .	8-22
8-11. Hayes Modem Cable Parts List . . . . .	8-23
8-12. Hayes Modem and Direct Connect Cables Parts List . . . . .	8-24
8-13. LaserJet Cable Parts List . . . . .	8-25
A-1. Keyboard and Keyboard Display (LCD) Connector J1 . . . . .	A-2
A-2. Printhead Logic Connector J2 . . . . .	A-3
A-3. Printer Motor and Sensor Connector J3 . . . . .	A-4

A-4. Battery Connector J4 . . . . .	A-5
A-5. Printhead Power Connector J5 . . . . .	A-5
A-6. Patient Module Connector J9 . . . . .	A-6
A-7. RS-232 Connector J10 . . . . .	A-7
A-8. System Expansion Connector J12 . . . . .	A-8
A-9. Disk Power Connector J14 . . . . .	A-9
A-10. Disk Drive Logic Connector J15 . . . . .	A-10
A-11. Preview Display Logic Board, J1, to Preview Display Power Supply Board, J2 . . . . .	A-11
A-12. Power Supply to LCD Module, J1 . . . . .	A-12
A-13. Power Supply to LCD Module, J2 . . . . .	A-12
B-1. Acquisition Configuration Fields . . . . .	B-4
B-2. Measurement/Processing Configuration Fields . . . . .	B-5
B-3. SAECG Testing Problems . . . . .	B-15
B-4. Patient Module and Patient Data Cable . . . . .	B-15
B-5. SAECG Parts List . . . . .	B-16
C-1. Transmit and Fax . . . . .	C-7
C-2. Fax Modem Parts List . . . . .	C-8
C-3. Fax Modem Cable Parts List . . . . .	C-9
C-4. Fax Modem and Quick Connect Cable Parts List . . . . .	C-10
D-1. AHA Lead Set and Patient Module Configurations . . . . .	D-2
D-2. IEC Lead Set and Patient Module . . . . .	D-2
D-3. Global Configuration Fields . . . . .	D-4
D-4. VCG Report Formats . . . . .	D-7
D-5. Troubleshooting . . . . .	D-10
D-6. VCG Parts List . . . . .	D-12



## Introduction

---

This chapter introduces you to the M1700A PageWriter XLi, M1701A PageWriter XLs, and M1702A PageWriter XLe cardiographs and lists their technical specifications.

### Warning



**These cardiographs are only to be serviced by qualified personnel.**

---

### Note



**Safe and effective use of medical instrumentation requires periodic inspection and preventive maintenance.** Perform the preventive maintenance procedures in Chapter 4 of this manual at required intervals to ensure satisfactory instrument performance.

The cardiographs use a thermal printhead to record waveforms and label the ECG report. The paper supplied with the cardiographs is a special thermal paper designed specifically to work with the thermal printhead and the photo detector used to advance the paper.

The cardiograph's disk drive (M1700A & M1701A only) is a critical part. Disks of substandard quality can damage the drive or destroy patient data.

Hewlett-Packard guarantees the performance of the cardiographs only when used with paper and disks that meet or exceed Hewlett-Packard specifications.

---

---

## PageWriter XL Cardiographs

The M1700A PageWriter XLi is Hewlett-Packard's full-featured, interpretive cardiograph. The M1701A PageWriter XLs is the standard, non-interpretive cardiograph. The M1702A PageWriter XLe is the basic, non-interpretive cardiograph. Each cardiograph uses a patient module, which is a remote "front end" that acquires and digitizes data. The M1700A and M1701A patient modules feature a start button and an LCD display that indicates signal quality. The M1702A patient module does not feature a display or start button. The cardiograph main unit has the user controls, the disk drive (M1700A and M1701A only), the printer, and all the processing circuitry. All models use the same enclosure, except when the M1700A is equipped with preview display. The models fit onto the M1705A cart designed for these cardiographs. Figure 1-1 shows the M1700A with preview display mounted on the cart.

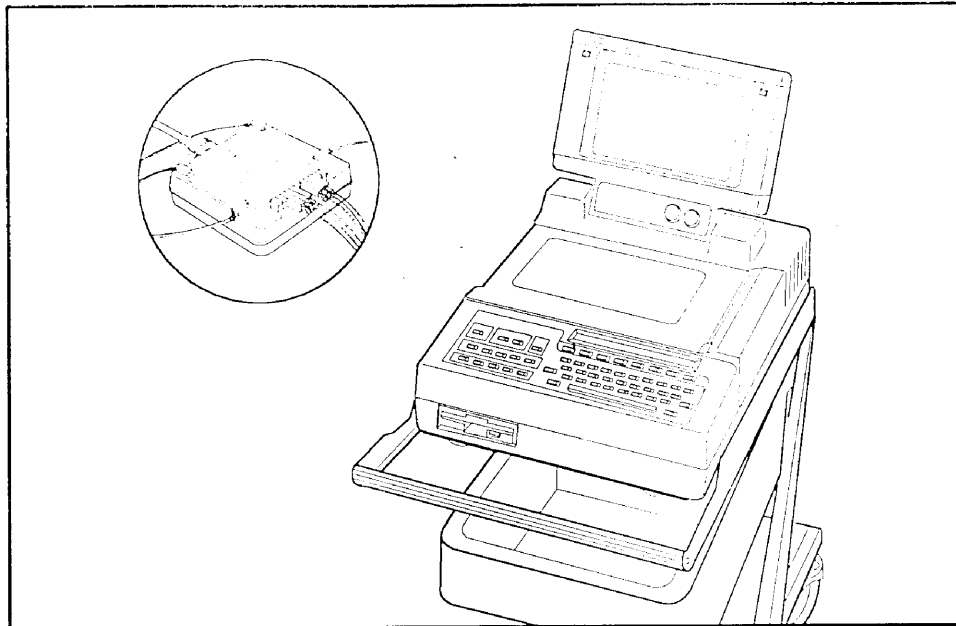

Figure 1-1. M1700A PageWriter XLI Cardiograph with Preview Display.

The PageWriter XL family of cardiographs can print ECGs in Auto and Manual formats for different clinical tests or applications. Both cardiographs print all traces with a continuous feed, high-resolution, digital array printer. This produces electrocardiograms on standard page lengths that require no cutting or mounting. Records are clearly annotated with ECG data and patient information. The M1700A also labels records with automatic ECG measurements and ECG interpretation for both adult and pediatric patients.

The M1700 and M1701A cardiographs use flexible disks for storing ECGs. Exact ECG copies can be made at the bedside or later. Each ECG is automatically logged and can be automatically stored by the cardiograph. A list of all stored ECGs can be printed, facilitating administrative reporting and billing. Typically, 50-150 ECGs can be stored per flexible disk, although the actual quantity depends on usage.

From a service standpoint, the PageWriter XL cardiographs are similar except for five major hardware differences:

- The M1700A preview display allows you to view the ECG prior to recording.
- The M1700A CPU assembly has extra memory to accommodate the measurement and interpretation software, but uses the same ROM as the M1701A.
- Each PageWriter has a unique CPU assembly.

- The M1700A and M1701A load software from, and store ECGs to, the disk drive. The M1702A software is in ROM, and does not store ECGs.
- The M1700A and M1701A patient modules feature a display that indicates signal quality and a start button. The M1702A patient module does not offer these features.

All other model differences are found in the cardiograph's software. The M1700A and M1701A software is installed in the cardiograph from flexible disk, while the M1702A software is installed from ROM. After installation, the software is stored in dynamic RAM (DRAM). Re-installation is required only when a user desires a different configuration, or if DRAM loses its contents due to a low battery.

The PageWriter XL family of cardiographs is designed for long-term reliability. The modular design makes extensive use of VLSI and gate array technology, resulting in a minimum number of major subassemblies. The modular approach means less down-time for the user, since replacing subassemblies allows quicker field repairs. The extended self-test efficiently identifies faulty subassemblies, further speeding the repair process.

**Note**



---

As of February 1992, all new PageWriter XL cardiographs are manufactured to a revised mechanical design specification. All units having a serial number prefix of 3208A or later conform to this revised specification. This manual describes all specific differences.

---

The following paragraphs describe some of the significant options available for the PageWriter XL cardiographs.

**M1705A Cart**

The M1705A Cart provides mobility for the PageWriter XL family of cardiographs. The large wheels make the cart easy to move, yet steady when in use. Slots in the cardiograph's feet and a thumbscrew secure the cardiograph to the cart rails. The tray directly below the cardiograph provides storage for acquired ECGs, the user's guide, and several flexible disks. The tray also has molded fittings that accommodate the modem in the M1706A Telecommunications Package. Storage for the power cable is built in, and other built-in cable retainers hold the patient data cable out of the way. Two compartmented trays provide storage for the patient module, spare patient electrodes and leadwires, additional thermal paper, consumable supplies, and miscellaneous items. An optional paper management tray is also available for the M1705A.

**M1706A  
Telecommunications  
Package**

With the addition of the M1706A Telecommunications Package, the M1700A can transmit ECGs over telephone lines to another site. The receiver at the other site can be a Hewlett-Packard ECG Management system or another M1700A. This feature is not available for the M1701A.

The M1706A Telecommunications Package consists of a Hayes<sup>®</sup> modem, a bracket that attaches the modem to the cart, a power cable that connects to the modem power outlet on the cardiograph, and data cables that connect the modem to the cardiograph and the telephone system. Local laws, regulations, and phone system standards determine the specific type of modem and accessories included and the types of cables included in the M1706A Telecommunications Package.

**M1755A A.03.XX  
Software**

This software is shipped with PageWriter XLi on a standard basis. This revision provides the PageWriter XLi with severity-only analysis, LaserJet printing option, and extended configurable transmission phone numbers. This revision includes all A.02.XX enhancements and also provides fax transmission, SAECG, and VCG capabilities. The software is shipped with all new PageWriter XLi cardiographs in late 1992.

**A.02.XX Software**

This software revision provides the PageWriter XLi with enhanced preview displays, interactive query, and FAA transmission. The software also gives the XLi fax transmission and SAECG capabilities. This revision is only available for support purposes.

**A.01.XX Software**

The original software for PageWriter XLi provides all basic features with preview display. This revision is only available for support purposes.

---

## **Inquiries**

Refer any questions or comments regarding these instruments to the nearest Hewlett-Packard Sales/Service Office or to one of Hewlett-Packard's Service Dispatch Centers. They can provide you with additional information about service training, special applications, and schematics. Always identify the instrument by model number and serial number in all correspondence. Hewlett-Packard sales and service offices are listed at the end of this manual. Toll-free numbers for Service Dispatch Centers are listed in Chapter 8, "Parts List."

## Specification Data

The following tables list the technical specifications for the cardiographs and the mobile cart. Specifications are the same for all models except as noted.

**Table 1-1. Physical Specifications**

Parameter	Specification
Dimensions (l x w x h)	
patient module	4 in x 5 in x 1.5 in (10.11 cm x 12.7 cm x 3.81 cm)
cardiograph	15.5 in x 22.25 in x 5.5 in (39.37 cm x 56.5 cm x 14 cm)
cart	33.37 in x 17.12 in x 36.0 in (84.76 cm x 43.48 cm x 91.44 cm)
Weight	
patient module	15 oz. (425.25 g) or less
cardiograph	46 lbs. (20.87 kg) or less (includes battery and preview display)
cart	38 lbs. (17.24 kg) or less
Connector life	
patient module	350 cycles (insertions)
RS-232	350 cycles (insertions)
Chemical resistance, cleaners	Withstands the following: isopropyl alcohol (except leadwires and patient data cable), mild soap and water, chlorine bleach and water (30 ml/l of water).

**Table 1-2. Patient Module Specifications**

Parameter	Specification
Resolution	5 $\mu$ V after processing
Input impedance	25 M $\Omega$ @ 10 Hz, typically 100M $\Omega$ @ DC
Gain accuracy	$\pm$ 3% of input signal +10 $\mu$ V
Input bias	40 nA or less for electrode wire input, less than 500 nA for Right Leg
Common mode rejection	110 dB or greater with AAMI load
Patient isolation, risk currents	10 $\mu$ A RMS or less @ 240 V AC 50 Hz, or 120 V AC 60 Hz
Defibrillator protection	System recovery 5 seconds after 400 joule discharge, no damage
Crosstalk rejection	50 dB or greater with 10 mV p-p on other channels
Calibration signal	1 mV $\pm$ 2% after processing
Sample rate	4 kHz
DC offset tolerance	$\pm$ 300 mV

Table 1-3. SAECC Patient Module Specifications

Parameter	Specification
Resolution	1.22 $\mu$ V after processing in high-resolution mode 5 $\mu$ V after processing in standard mode
Input impedance	25 M $\Omega$ @ 10 Hz, typically 100M $\Omega$ @ DC
Gain accuracy	$\pm$ 2% of input signal
Input bias	40 nA or less for electrode wire input, less than 500 nA for Right Leg
Common mode rejection	120 dB or greater with AAMI test load
Patient isolation, risk currents	10 $\mu$ A RMS or less @ 240 V AC 50 Hz, or 120 V AC 60 Hz
Defibrillator protection	System recovery 5 seconds after 400 joule discharge, no damage
Crosstalk rejection	50 dB or greater with 10 mV p-p on other channels in standard mode
Calibration signal	1 mV $\pm$ 2% after processing
Sample rate	8 kHz
DC offset tolerance	$\pm$ 55 mV

Table 1-4. ECG to Paper Specifications

Parameter	Specification
Frequency response	
Auto ECG	3 dB down at (user selectable): 0.05-150 Hz, 0.15-150 Hz, 0.5-150 Hz, 0.05-100 Hz, 0.15-100 Hz, or 0.5-100 Hz, 0.15-40 Hz, 0.5-40 Hz
Manual ECG	3 dB down at (user selectable): 0.05-40 Hz, 0.05-150 Hz, 0.5-40 Hz, 0.5-100 Hz, 0.05-100 Hz
SAECC	3 dB down at (user selectable): 25-300 Hz, 40-300 Hz, 80-300 Hz
power line	115 dB rejection at 50 or 60 Hz with less than 300 mV DC offset
ECG resolution on paper	
voltage axis	200 dots/in (8 dots/mm)
time axis	500 dots/in (20 dots/mm) at 25 mm/s and slower 250 dots/in (10 dots/mm) at 50 mm/s

Table 1-5. Power Supply and Battery Specifications

Parameter	Specification
AC line frequency	50 and 60 Hz
100 V setting	100 V AC nominal
120 V setting	120 V AC nominal
220 V setting	220 and 230 V AC nominal
240 V setting	240 V AC nominal
Battery voltage	18 V DC, 6.5 Ahr
Battery recharge time (from 70% down) to 90% capacity	8 hours typical
to full capacity	16 hours typical
Battery capacity, M1700A with preview without storage	30 ECGs (40 typical)
with storage	30 ECGs (40 typical)
continuous rhythm (Manual mode)	20 minutes (30 typical)
continuous idle	2 hours (3 typical)
Battery capacity, M1700A without preview without storage	50 ECGs (70 typical)
with storage	45 ECGs (60 typical)
continuous rhythm (Manual mode)	30 minutes (40 typical)
continuous idle	4 hours (6 typical)
Battery capacity, M1701A without storage	55 ECGs (75 typical)
with storage	50 ECGs (70 typical)
continuous rhythm (Manual mode)	30 minutes (40 typical)
continuous idle	4 hours (6 typical)
Battery capacity, M1702A continuous rhythm (Manual mode)	55 ECGs (75 typical) 30 minutes (40 typical)
continuous idle	4 hours (6 typical)
Battery life AC and battery operation	Typically 24 months
battery only operation	Typically 12–18 months
Memory data retention time with fully charged battery	Typically 1 month
after “Low battery shutdown”	Typically 5 days
Modem power	9 V AC for Hayes® modem 9 V DC for Worldport 2496™ Fax/Data modem
Ground leakage current at 120 V	Less than 100 $\mu$ A
at 220 V	Less than 500 $\mu$ A
Dielectric withstand voltage	1.5 kV RMS across line/neutral to Earth for 1 min.

Table 1-6. Environmental Specifications

Parameter	Specification
Temperature	
operating	41°-115° F (5°-45° C)
storage	14°-122° F (-10°-50° C)
Humidity	
operating	20-80% RH, non-condensing
storage	10-85% RH, non-condensing
Pressure (altitude)	
operating	To 15,000 ft (4600 m)
storage	To 50,000 ft (15000 m)

Table 1-7. Miscellaneous Specifications

Parameter	Specification
Real time clock accuracy	
25° C	1.5 minutes per month
5°-45° C	5 minutes per month
RS-232 bit transmission rates	300, 1200, 4800, 9600, 19200 baud
Printhead life	Typically 100,000 pages

---

## Options and Accessories

### PageWriter XLi, XLs and XLe Cardiographs

These tables list the options and accessories available for Page-Writer XL cardiographs.

#### Country Options

Each country option includes appropriate power cord, voltage, printer, patient module, and language. See Table 1-8, which shows the configuration of each country option.

ABA	North American Version
ABB	European English Version
ABC	French Canadian Version
ABD	German Version
ABE	Spanish Version
ABF	French Version
ABG	Australian Version
ABH	Dutch Version
ABK	Intercon English Version
ABM	Latin American Version
ABS	Swedish Version
ABU	U.K. Version
ABZ	Italian Version
AB4	Singapore Version
ACF	Japanese Version
ACQ	South African Version
AKM	Chinese Version
AKV	South American Version

#### Delete Options

D01	Delete preview display (M1700A only)
D02	Delete cart (M1700A, M1701A only; the M1702A is shipped without a cart)
D03	Delete standard AHA patient module
D04	Delete standard IEC patient module
D05	Delete analysis from the M1700A
D06	Delete analysis and preview from the M1700A

#### Cable Options

Cable options are applicable to the M1700A only.

J01	Direct transmission cable (24542M)
J02	ECG WorkStation adapter (92224F)

### Supplies/Accessories Options

A01	Add paper tray to M1705A cart (M1705-89500)
K01	Extra leads kit (Frank, pediatric, research leads) (M1717B)
K02	9-meter patient data cable (M1720A)
K03	Extra paper (8.5×11, 1 case/1600 sheets) (M1707A)
K04	Extra A4 paper (1 case/1600 sheets) (M1709A)
K05	Dust cover (M1700-87600)
K06	Extra disposable electrodes (6 boxes each of 13943B, 1000/box; 1 set 13946A electrode adapters included)
K07	LaserJet printer cable
906	Swiss power cord

### Substitute Options

S01	Substitute inch size (1/8in post) reusables
S02	Substitute metric size (4mm post) reusables

M1702A only:

S03	Substitute standard AHA patient module
S04	Substitute standard IEC patient module

### Documentation Options

0B3	PageWriter XL Series Service Manual (English only) (M1700-91909)
0BP	User Training Video (VHS-NTSC) (M1700-89000)
0BQ	User Training Video (VHS-PAL) (M1700-89001)

### Standard Accessories Supplied

- 2.5-meter patient data cable—M1719A
- 200 sheets z-fold paper—A size: M1707A; A4 size: M1709A
- 10 universal adapters—13946A
- 300 solid gel tab electrodes—13943B
- Disposable electrodes and adapters are standard supplies. Use S01 and S02 options to obtain reusables.

#### S01:

- 6 Welsh bulb electrodes—40421A (1/8in post)
- 4 limb electrodes—40424A (1/8in post)
- 4 limb straps—14030A
- 1 tube Redux<sup>®</sup> creme—651-1021-050

#### S02:

- 6 Welsh bulb electrodes—40490E (4mm banana)
- 4 limb electrodes—40491E (4mm banana)
- 4 limb straps—14030A

- Tube Redux<sup>®</sup> creme—651-1021-050
- *PageWriter XLi Operating Guide* (M1700A only)
- *PageWriter XLi Cardiograph User's Reference Guide* (M1700A only)
- *PageWriter XLi Cardiograph Physician's Guide* (M1700A only)
- *PageWriter XLs User's Guide* (M1701A only)
- *PageWriter XLe User's Guide* (M1702A only)
- *Signal Averaged ECG User's Guide* (M1754A only)
- *Vectorcardiography (VCG) User's Reference Guide* (M1790A only)
- Two blank, 1.44-Mb high-density disks (reorder M1700-89004, box of 10 disks)
- System software version A.03.XX (M1755A)—M1700-17720 (M1700 only)
- System software version A.01.01 (M1701A) —M1701-17700 (M1701 only)
- D06 system software version A.01.01 (M1700A)—M1700-17711 (M1700A option D05 and D06 only)

**M1703A PageWriter XLi  
Upgrade Kits**

**Options**

A01            Add Preview Display

**M1704A PageWriter XLs  
Upgrade Kits**

Country option must also be ordered.

**Options**

A01            Upgrade XLs to XLi

**M1706A  
Telecommunications  
Package**

M1706A includes bracket and cable. Country option must also be ordered.

**Options**

ABA            U.S. Modem (Hayes<sup>®</sup> 2400)  
 ABC            Canada Modem (Hayes<sup>®</sup> 2400)  
 ABE            Spain Modem (Hayes<sup>®</sup> 1200)  
 ABF            France Modem (Hayes<sup>®</sup> 2400)  
 ABH            Netherlands Modem (Hayes<sup>®</sup> 1200)  
 ABU            U.K. Modem (Hayes<sup>®</sup> 2400)

ABZ Italy Modem (Hayes® 1200)  
K01 Quick Connect cables for Hayes® modem  
(M1706-61636 and M1706-61637)

**M1753A PageWriter XLi  
Upgrade Kit**

Country option must also be ordered.

**Options**

A01 Upgrade XLi to XLs

**M1754A PageWriter XLi  
Signal Averaged ECG  
System**

Includes M1754-17700 A.01.00 SAECG software set, SAECG patient module, and operator's guide. Country option must also be ordered.

**Note**



The M1754A option requires the M1755A (A.02.XX, A.03.0X or higher) software. The M1754A option will not function with A.03.1X software.

**Documentation Options**

0BP SAECG User Training Video VHS/NTSC  
(M1754-89504)

0BQ SAECG User Training Video VHS/PAL  
(M1754-89505)

**M1755A PageWriter XLi  
Upgrade Kit**

Upgrade to version A.03.XX operating software. Includes two system disks and two blank disks. Specify country option.

**Note**



This software revision is the standard software that ships with all XLi cardiographs as of late 1992.

**M1756A PageWriter XLi  
Direct Digital ECG Fax  
Modems**

Includes M1756-07300 fax modem bracket and M1756-61600 fax modem cable.

**Note**



The M1756A option requires the M1755A (A.02.XX or higher) software.

**Options**

ABA U.S. fax modem (Worldport® 2400) (M1756-89501)

ABC Canada fax modem (Worldport® 2400)  
(M1756-89502)

ABD Germany fax modem (Worldport® 1200)  
(M1756-89507)

ABF	France fax modem (Worldport® 2400) (M1756-89503)
ABH	Netherlands fax modem (Worldport® 1200) (M1756-89504)
ABU	U.K. fax modem (Worldport® 2400) (M1756-89505)
ABX	Italy fax modem (Worldport® 1200) (M1756-89506)
K01	Quick Connect cables for fax modem (M1756-61601 and M1706-61636)

**M1788A Extra Patient  
Module**

Includes patient module, lead set, and disposable electrodes kit.

**Options**

A01	Standard AHA patient module
A02	Low cost AHA patient module
A03	Standard IEC patient module
A04	Low cost IEC patient module

**Substitute Options**

S01	Substitute inch size (1/8in post) reusables
S02	Substitute metric size (4mm post) reusables

**M1790A PageWriter XLi  
Vectorcardiography**

Includes M1790-17700 A.01.00 VCG software set, VCG leadwires, and manuals. Country option must also be ordered. The part number for replacement leadwires is M1717B.

**Note**



The M1790A option requires the M1755A (A.03.1X) software version. The M1790A option will not function with the A.03.0X software.

**Country Option Configurations**

The following table gives the configuration of each country option.

**Table 1-8. Country Option Configurations**

Option	Country	Labels	Manuals	Printer	AHA/IEC	Volts	Power Cord
ABA	North American	English	English	A	AHA	120	US
ABB	European English	English	English	A4	IEC	220	Europe
ABC	French Canadian	French	French	A	AHA	120	US
ABD	German	German	German	A4	IEC	220	Europe
ABE	Spanish	Spanish	Spanish	A4	IEC	220	Europe
ABF	French	French	French	A4	IEC	220	Europe
ABG	Australian	English	English	A4	AHA	240	Australia
ABH	Dutch	Dutch	Dutch	A4	IEC	220	Europe
ABK	Intercon English	English	English	A	AHA	220	Europe
ABM	Latin American	Spanish	Spanish	A	AHA	120	US
ABS	Swedish	Swedish	Swedish	A4	IEC	220	Europe
ABU	United Kingdom	English	English	A4	IEC	240	UK
ABZ	Italian	Italian	Italian	A4	IEC	220	Europe
AB4	Singapore	English	English	A4	AHA	240	UK
ACF	Japanese	English	English	A4	IEC	100	US
ACQ	South African	English	English	A4	IEC	220	SA
AKM	Chinese	English	English	A4	IEC	220	Australia
AKV	South American	Spanish	Spanish	A	AHA	220	Europe

**Note**



In Table 1-8 an “A” in the **Printer** column refers to 8.5 × 11-in paper; “A4” refers to 210 × 297-mm paper.

## Installation and Configuration

---

This chapter describes how to install and configure the PageWriter XL M1700A, M1701A, and M1702A cardiographs. This information provides you with a factory-recommended process to use when assisting customers. The configuration information guides you through the configuration menu structure, and describes the configuration choices.

---

### Installation

The cardiograph is ready for operation when the following tasks have been properly performed:

- Patient data cable connected.
- Patient electrodes and leadwires installed on patient module.
- Voltage setting and fuse checked.
- Battery installed.
- Software installed (M1701A & M1700A only).
- Language and line frequency chosen.
- Paper installed.
- Clock set (time and date).
- Configuration parameters chosen.
- Configuration saved to disk (M1701A & M1700A only).

In addition to these tasks, the cardiograph should be mounted on the cart if you are using a cart, and the modem attached to the cart if you are using a modem.

## Installing the Cardiograph and Modems on the Cart

To install the cardiograph on the cart:

1. Set the cardiograph on the top rails so that the cardiograph's rear feet drop into the notches on the horizontal rail edges. The operator panel must face the cart handle.
2. Slide the cardiograph away from the handle, making sure that the slots on the feet engage the rail edges.
3. Lock the cardiograph in place by installing the locking screw. The locking screw passes through the hole in the left cart rail and screws into the threaded hole on the left underside of the cardiograph.

Attach the Hayes® modem to the cart as shown in Figure 2-1:

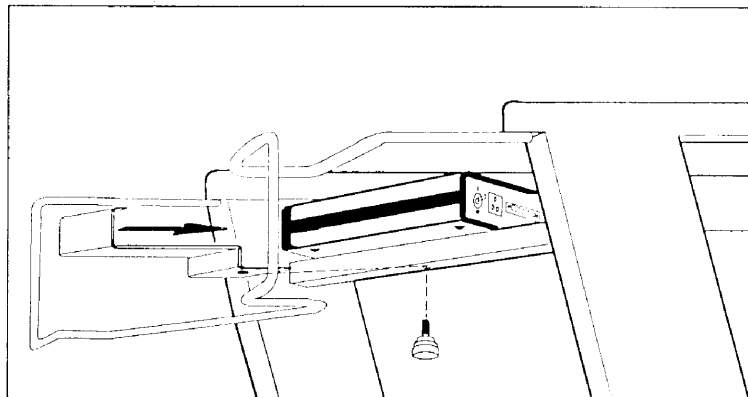

Figure 2-1. Installing the Hayes® Modem.

### Installing the M1756A Fax Modem

To install the fax modem, perform the following steps (see Figure 2-2):

1. Press the **On-Standby** switch to turn the cardiograph to Standby.
2. Turn the cardiograph AC switch off.
3. Insert the larger connector end of the fax/modem cable (M1752-61600) into the RS-232C plug on the fax/modem, as shown in Figure 2-2.
4. Place the fax/modem flat into the bracket so that its data cable is retained by the two upright tabs at the narrow end of the bracket. The battery compartment should be accessible through the cutout at the wide end of the bracket.

#### Note



A 9-volt battery is not essential for fax/modem operation.

5. From the rear of the cart, with the data cable away from you, pass the modem under the horizontal square bar.

6. Pull the modem towards you, so that the clip on the bracket is securely over the horizontal bar.
7. Align the hole in the bracket with the tapped hole on the underside of the bar and secure the modem with the knurled screw.
8. Bring the fax/modem cables up over the square bar and insert the smaller end of the fax/modem cable into the plug on the back of the cardiograph marked Data Comm. Tighten the retaining screws.
9. Plug the round end of the fax modem cable into the cardiograph's modem power connector. Secure the retaining screws.
10. Insert the telephone cable into either phone connector on the side of the fax modem.

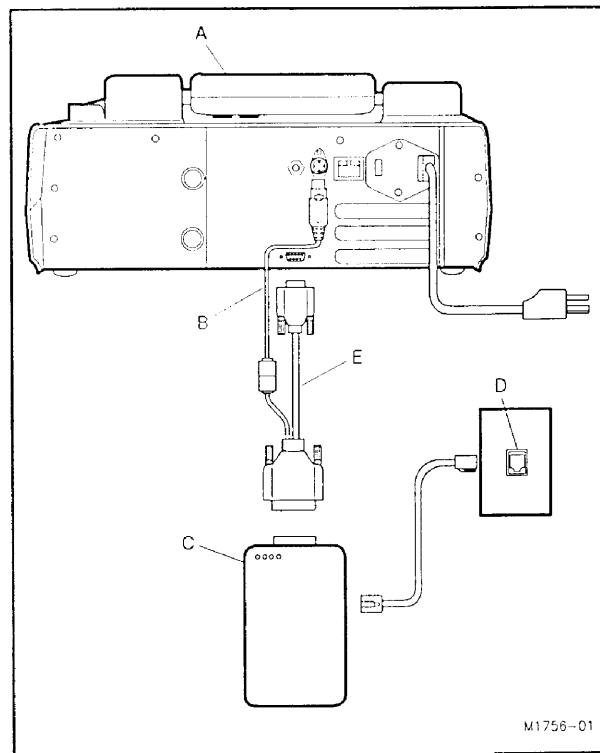

**Figure 2-2. Connecting the Fax Modem Cables.**

- A. PageWriter XLi Cardiograph
- B. Fax Modem Power Cable
- C. Fax Modem
- D. Phone Line Connector
- E. Fax Modem Data Cable

Note



For modem cabling variations see Chapter 8, Parts Lists.

## Printing an ECG on an HP LaserJet Printer

You can print stored ECGs on an HP PCL5 LaserJet printer. Figure 2-3 shows how to connect the cables between the cardiograph and the printer.

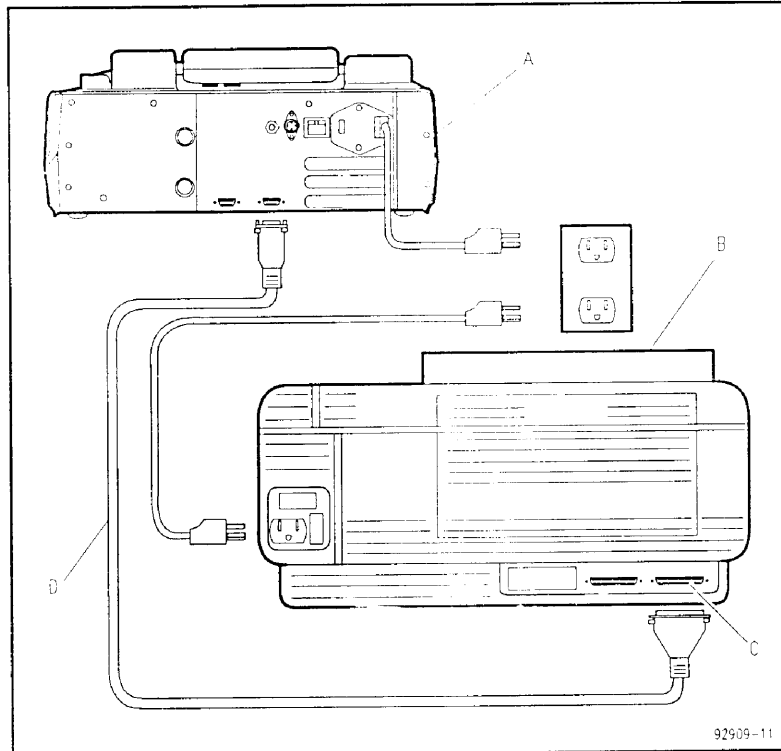

Figure 2-3. Connecting the Printer Cable.

- A. PageWriter XLi Cardiograph
- B. LaserJet Cable (HP 24542G)
- C. HP LaserJet Printer Serial Interface Port

---

## Setting up the LaserJet Printer

You must set up the LaserJet printer for serial printing before using it to print stored ECGs from the cardiograph. To configure the printer for serial printing, perform the following steps.

1. With the printer on, press the ON LINE key until the light is off.
2. Press the MENU key on the printer to step through the settings until I/O=PARALLEL\* appears.  
If I/O=SERIAL\* appears, the printer is already set for serial printing.
3. Press the + key until I/O=SERIAL appears.
4. Press the ENTER key on the printer. An asterisk will appear on the display: I/O=SERIAL\*.
5. Press the MENU key and the BAUDRATE setting will appear.
6. Press the + key until BAUDRATE=19200 appears.
7. Press the ENTER key on the printer. An asterisk will appear on the display: BAUDRATE=19200\*.
8. Press the ON LINE key.  
The printer is ready to use with your cardiograph.

**Configuring the  
Cardiograph to Print  
ECGs on the HP  
LaserJet**

After connecting the cables, you must configure the cardiograph for printing on the HP LaserJet.

1. Press **Menu** until the following display appears:

```
Transmit Store   Config CheckDisk Files
```

2. Press **Config**. The main configuration menu will appear:

```
Configuration  
Global   ID   Transmit Files   Exit
```

3. Press **Transmit** and the Transmit Configuration menu appears in the display.

```
Configuration  
Transmit Receive AutoDial      Exit
```

1. Press **Transmit** to configure any of four transmission sites. The Configure Site menu will appear:

```
Configure Site  
1       2       3       4       Exit
```

5. Select a site number and the following display appears.

```
Connection? None  
Enter   Choose      Exit
```

6. Press **Choose** until you see the choice **LaserJet**, then press **Enter**. The baud rate display will appear.
7. Press **Choose** until you see the baud rate **19200**, then press **Enter**.
8. Select whether to print a grid.  
If you have unlined paper in the printer, this selection will print the grid with the ECG.

Your cardiograph is now set up to print to an HP LaserJet when you select the configured site from the **Transmit** menu. See the *PageWriter XLi Operating Guide* for information about transmitting ECGs.

### Connecting the Patient Module

1. Connect the patient data cable to the ECG input jack on the back of the cardiograph.
2. Connect the other end of the patient data cable to the patient module as shown in Figure 2-4.
3. Connect the leadwires to the patient module. Match the color coding on the leadwires to the color coding on the patient module. (M1702A only: Match the labels on the leadwires to the labels on the patient module.)
4. Install shorting plugs in the patient module in those positions without leadwires.

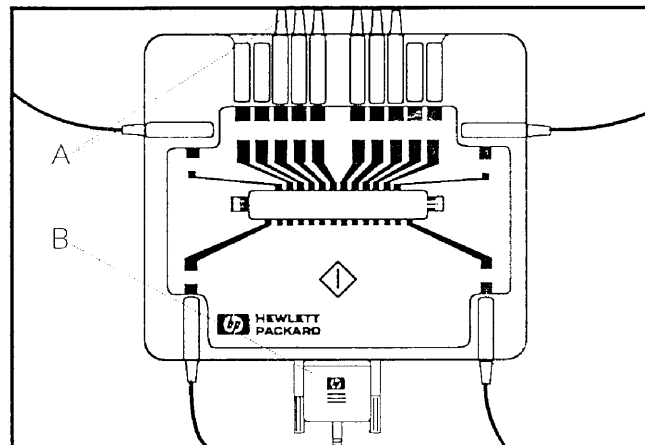

Figure 2-4. Connecting the Patient Module.

- A. Leadwires
- B. Patient Data Cable

Note



The M1702A patient module does not feature a signal quality display or a start button.

Note



The M1754A SAECC patient module can acquire both SAECC and standard ECGs. To get the best results for SAECC, remove the LL and LA leadwires and install shorting plugs in the LL and LA inputs.

### Changing the Line Voltage Setting

The cardiograph can be set to operate at nominal line voltages of 100, 120, 220, 230, or 240 Volts. It was set at the factory to the line voltage in your area. Nevertheless, it is a good idea to check the setting, especially if the cardiograph was brought from an area with a different line voltage.

Caution



The cardiograph can be damaged if plugged into the incorrect voltage or if fused incorrectly.

The voltage setting appears in the line module window. The line module is located on the rear panel immediately to the right of the AC switch (see Figure 2-5). If the voltage setting is incorrect, change it to the correct setting for your area using the procedure that follows. If you need to change the voltage setting, be sure to also check the line fuses.

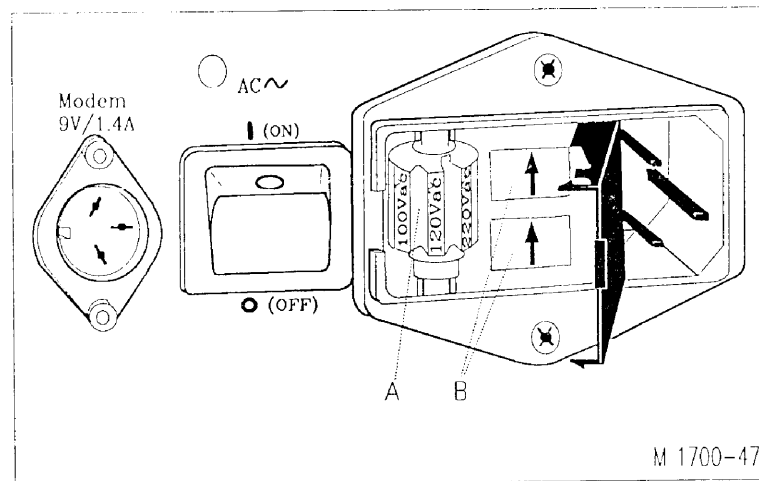

Figure 2-5. The Line Module and AC Switch.

- A. Voltage selection drum
- B. Fuse holders

To change the voltage setting:

1. Unplug the power cord from the line module.
2. Open the line module door with a small bit screwdriver.
3. Remove the voltage selector drum from the line module. The voltage selections (marked on the selector drum) are 100, 120, 220, or 240.

**Caution**



Do not rotate the voltage selector drum while it is installed. Doing so will damage the drum and the line module assembly.

4. Rotate the drum so that the correct voltage will appear in the window when the line module door is closed, then reinstall the drum. Table 2-1 shows the correct settings for each nominal line voltage.

**Table 2-1. Line Voltage Settings**

Nominal Line Voltage	Voltage Setting
100	100
120	120
220, 230	220
240	240

5. Pull out the fuse holders and check that the line fuses are the correct rating for the selected voltage (see Table 2-2). If the fuses are correct, reinstall the fuse holders and proceed to the next step. If the fuses are incorrect, proceed to the next procedure, "Changing the Line Fuses."
6. Close the line module door. Check again that the correct voltage setting for your area appears in the window.

**Table 2-2. Line Fuse Ratings for Voltage Settings**

Voltage Settings	Line Fuse Required
100, 120	2.5 A, 250 V, 3AG style time delay fuse (HP part number 2110-0015)
220, 240	1.6 A, 250 V, 5 x 20 mm time delay fuse (HP part number 2110-0773)

## Changing the Line Fuses

The cardiograph uses two line fuses. Table 2-2 lists the fuse rating requirements for the line voltages. The correct fuse must be installed in the cardiograph before you turn it on. Fuse rating requirements are also printed on the product rating label on the back of the cardiograph.

1. Unplug the power cord from the line module.
2. Open the line module door with a small bit screwdriver.
3. Pull out the fuse holders and check that the line fuses are the correct rating for the selected voltage. Refer to Table 2-2. If you need to install line fuses with a different rating, you will also need different fuse holders. Fuses for lower voltages require fuse holder part number 2110-0686; fuses for higher voltages require fuse holder part number 2110-0687.
4. Place the fuses in the fuse holders and push each fuse holder back into the line module. Make sure that the arrows on the fuse holders point in the same direction as the arrows on the line module door.
5. Close the line module door.

## Installing the Battery

This procedure describes installing the battery for the first time. If you are replacing a battery, refer to the battery replacement procedure in Chapter 7, "Removal and Replacement."

### Note



The cardiograph is primarily a battery-powered instrument. It will not operate without the battery, even if it is plugged into AC power. Use only HP battery assembly M1721A.

### Warning



The battery is relatively heavy for its size. Support the battery from underneath as you install it to prevent it slipping and possibly causing injury.

To install the battery:

1. Open the cardiograph's battery compartment by loosening the two thumbscrews on the back of the cardiograph (as shown in Figure 2-6), and pulling the battery holder out.

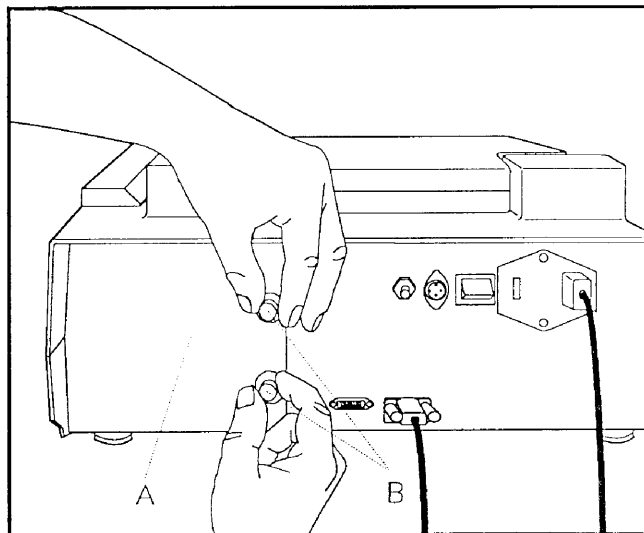

Figure 2-6. Installing the Battery.

- A. Battery door
- B. Thumbscrews

### Note



Figure 2-6 shows the M1700A; other models are similar.

2. Install the battery on the battery holder. Make sure the tab on the door fits into the slot on the battery (refer to Figure 2-7).

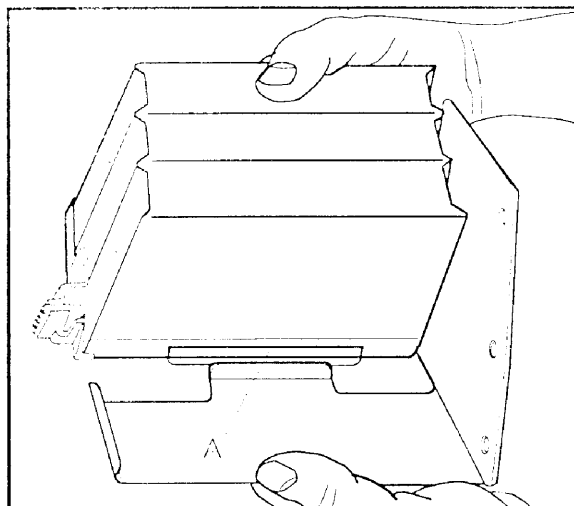

Figure 2-7. Fitting the Battery Holder Tab Into the Battery Slot.

- A. Battery slot
3. Gently slide the battery and holder into the battery compartment until completely seated.
  4. Finger-tighten the thumbscrews on the battery holder.
  5. Connect the power cord to the cardiograph, then plug the cord into an AC outlet.
  6. Turn on the AC switch on the back of the cardiograph. The green AC indicator on the front panel should light up.
  7. Press the **On-Standby** switch to turn on the cardiograph. The cardiograph will begin its power-on sequence. The M1700A and M1701A cardiographs will briefly display PageWriter XLi or PageWriter XLs in the keyboard display, then display the code 6503 (this code indicates that the software is not yet installed and there is no System disk in the disk drive). At the same time, all of the control panel indicators will light up, including the red low-battery indicator and the green charge indicators. The M1702A cardiograph will display a line of asterisks for about two minutes as it loads software from its built-in ROM. During this time, it may prompt for language and line frequency.
  8. Press **On-Standby** again to place the cardiograph in Standby. When the cardiograph is in Standby, it is not operational, but it is powered.

Note



---

To ensure full battery capacity, charge the battery for 24 hours following its installation in the cardiograph.

---

**Caution**



If the cardiograph will be stored for longer than one month, remove the battery from the unit.

**Installing the Software on the M1700 & M1701A**

The software for the M1700 is provided on two disks and the software for the M1701A is provided on one disk. The software is loaded into memory when the disk is in the drive when the cardiograph is turned on.

To install the software:

1. Press the **On-Standby** switch to place the cardiograph in **Standby**.
2. Insert the appropriate system disk in the disk drive.
  - If you have no other applications to install, install the A.03.00 system disk (M1700-17920).
  - If you want to install M1754A SAECG software later, install the A.03.00 system disk (M1700-17920).
  - If you want to install M1790A VCG software later, install the A.03.10 option disk (M1700-17921).
  - If you have an M1701 PageWriter XLs cardiograph, install the M1701 system disk (M1701-17900).
3. Press **On-Standby** to turn the cardiograph **On**.
  - If no software is installed in the cardiograph, the cardiograph will begin immediately to load the software from the disk.
  - If software is already installed in the cardiograph, the prompt **Load configuration:** followed by the name of the configuration disk appears on the display.

**Note**



If you do not want to load the configuration shown, remove the disk and place the cardiograph in **Standby**. Find the correct disk and restart this procedure at step 2.

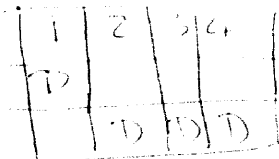

**Note**



If you load the software from a configuration disk, the language and line frequency prompts will not appear because these selections are part of the stored configuration. See "Configuration Files," later in this chapter.

5. When the software installation is complete, the main menu appears on the display. Remove the disk and store it in a cool, dry, dust-free location, away from magnetic fields.
6. Check the battery level and AC indicator lights. The AC indicator and one or more of the green battery level indicators should be lit. The red "low battery" indicator should be off, though if the battery is low the green indicators will be off and the red indicator will be on.

**Note**

---

The battery level indicators function only after software is installed. To verify battery capacity, turn on the unit while the cardiograph is connected to AC power and the AC switch is on. The cardiograph must be connected to AC power when verifying battery capacity.

---

Once the software is installed, it does not need to be reinstalled unless the cardiograph loses battery power or has a system failure, or if you want to load upgraded or custom-configured software.

**Installing the Software  
on the M1702A**

The software for the M1702A is stored in ROM and loaded into memory automatically when the cardiograph is turned on for the first time, or after the battery has been replaced. This process takes about two minutes. During this time, you will be prompted for language and line frequency.

**Loading the Paper**

The cardiograph uses continuous-feed thermal paper, HP part number M1707A (A size) or M1709A (A4 size). To load the paper:

1. Release the printer door latch on the left side of the cardiograph and slide the printer door to the left.
2. Remove the paper from its packaging but do not remove or discard the cardboard backing.
3. Slide the paper stack (cardboard down) into the compartment. The paper should feed grid-side up over the top panel of the printer door.
4. Pull the free end of the paper back to the far end (latch end) of the top panel (see Figure 2-8).
5. Slide the printer door back into place making sure that it latches.
6. Press **Page Advance** to advance the paper to the beginning of the next page.

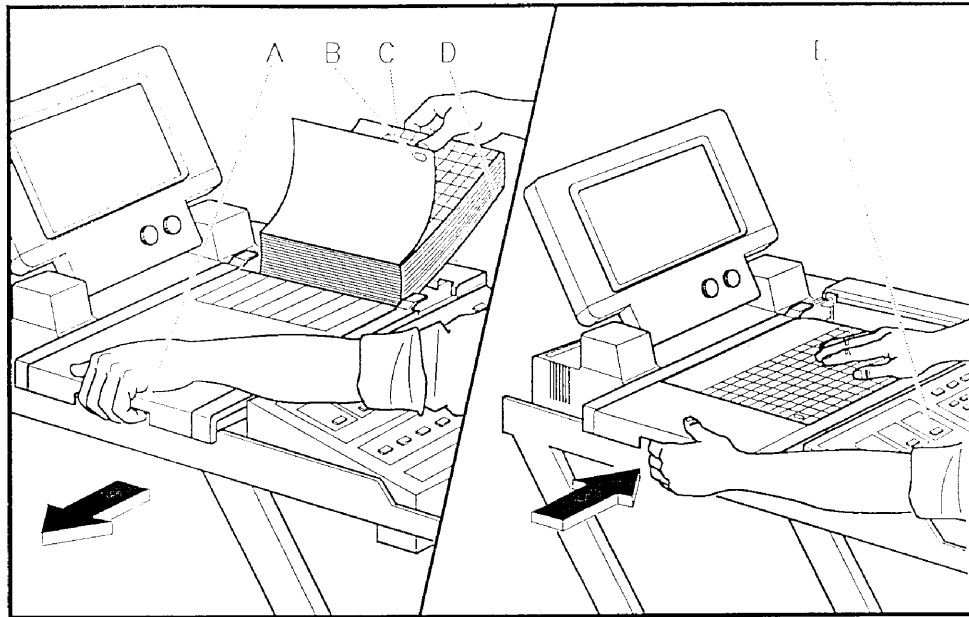

Figure 2-8. Loading the Paper.

- A. Paper Door Latch
- B. Paper Sensing Hole
- C. Paper
- D. Cardboard Backing
- E. Page Advance Key

## Setting the Date and Time

The main menu, shown here, allows you to set the date and the time.

```
Auto 3x4,3R I,II,III
Report Format Leads 04/01/1990 02:23:34PM
```

### Note



The date format, date separators, time format, and time separators are global configuration parameters. Changing the global configuration is explained later in this chapter.



To set the date, press the softkey directly below the date. The date change display appears:

```
Date? 04/01/1990 (MM/DD/YYYY)
Enter          Clear          Exit
```

To set the time, press the softkey below the time. The time change display appears:

```
Time? 02:23:34 PM (HH:MM:SS)
Enter    AM/PM    Clear    Exit
```

- |              |   |
|--------------|---|
| <b>Enter</b> | Stores an entry after checking its validity, then returns you to the main menu.                                 |
| <b>AM/PM</b> | Appears only for the time change display and only when the cardiograph is configured for the AM/PM time format. |
| <b>Clear</b> | Clears erroneous entries and returns the currently stored date or time to the display.                          |
| <b>Exit</b>  | Same as <b>Enter</b> .  |

When the change display appears, the cursor highlights the first (leftmost) digit of the date or time. To change the date or time, simply type in the new numbers. For example, to change the time to 03:45:12 PM, simply type the digits 034512. The system automatically inserts the separators in the proper places. To change a single digit, use the left and right arrow keys,  and , to move the cursor over the digit you want to change. Then type the new digit. When you are satisfied the new date or time is correct, press **Enter** or **Exit** to store it as the cardiograph's current date or time.

---

## Configuration

The cardiograph is designed to provide custom operation. The configuration parameters allow you to program the cardiograph for the most useful and efficient operation. Typically the cardiograph is configured only during initial installation.

### Note



Software revision A.02.00 (M1755A) allows you to select either XLI, Preview Plus, or SAECG as the default configuration. Set the **Power on application** global parameter to the application you want the cardiograph to start up in.

This section describes the menu structure that enables you to configure the cardiograph's operating parameters. Each menu choice is described briefly in a list, then in more detail in the narrative section that follows the list.

### Configuring the M1700A and M1701A

Press **Menu** until the following display appears:

Transmit	Store	Config	CheckDisk	Files
----------	-------	--------	-----------	-------

### Note



The **Transmit** key appears only on the M1700A. Only the M1700A has transmission capability.

Press the **Config** softkey to display the main configuration menu:

Configuration				
Global	ID	Transmit	Files	Exit

### Note



If this is not the initial configuration, you must type in the cardiograph's password (if one has been set) before you can make any changes to the configuration.

The softkeys function as follows:

Global	Allows you to set the operating parameters of the cardiograph. The Global configuration affects all cardiograph operations.
ID	Allows you to choose which patient identification entries are requested before recording an ECG.
Transmit	Allows you to set the communication parameters for transmitting and receiving ECGs. This key appears only on the M1700A because only the M1700A has ECG transmission capability.
Files	Allows you to store a configured copy of the cardiograph software to disk, or to print the configuration settings.
Exit	Returns you to the previous menu.

**Note**



When you make extensive changes to the system configuration, it is recommended that you print the configuration and save it on disk (the procedure for storing the system configuration is described under “Configuration Files” later in this chapter). If the software is lost due to loss of battery power, or if different configurations are used regularly on the same cardiograph, restoring a custom configuration is much quicker and easier from disk than by manually entering the changes.

**Configuring the M1702A**

Press **Menu** until the following display appears:

Configuration			
Global	ID	Print	Exit

Global	Provides access to the cardiograph’s operating parameters. Refer to Chapter 2.
ID	Provides access to the cardiograph’s operating parameters. Refer to Chapter 2.
Print	Prints the cardiograph configuration.
Exit	Returns to the main menu.

**Note**



You cannot save the M1702A configuration. You should print the M1702’s configuration, so that you can restore it if the battery is removed, or if changes are made to the configuration.



## Global Configuration

Pressing **Global** (from the configuration menu) brings up the parameter selection display. The first parameter in the Global list appears. Table 2-3 lists each Global parameter and its setting choices. The factory default settings are shown in **boldface** type. There are explanations following the table for those parameters that cannot be adequately explained in the table's Comments column.

**Table 2-3. Global Configuration Parameters**

Parameter	Setting Choices	Comments
Initial Interpretation? †	<b>Reasons</b> None Measure Interpret Severity only††	See "Interpretation Parameters" section following this table.
Copy Interpretation? †	<b>Reasons</b> Extend Measure None Severity only†† Choice Measure Interpret	See explanations following this table.
AutoStore?#	<b>Yes</b> No	Determines whether an Auto ECG is automatically stored without operator intervention.
Patient ID required?	<b>Yes</b> No	Appears only if AutoStore is "No." Determines whether the cardiograph will require patient ID information before recording an Auto ECG. If AutoStore is "Yes," this parameter is "Yes."

Table 2-3. Global Configuration Parameters (continued)

Parameter	Setting Choices	Comments
Auto Frequency Response?	.15-150 Hz .05-150 Hz .5-150 Hz W .15-40 Hz .5-40 Hz W .05-100 Hz .15-100 Hz .5-100 Hz W	W = Baseline Wander filter. See <i>PageWriter XLi Physician's Guide</i> for more information.
Manual Frequency Response?	.05-40 Hz .5-100 Hz W .05-100 Hz .5-150 Hz W .05-150 Hz .5-40 Hz W	W = Baseline Wander filter. See <i>PageWriter XLi Physician's Guide</i> for more information.
Line Power Filter?	Off On	A software filter that removes power line (AC) interference.
Line Power Frequency?	60 Hz 50 Hz	No default—selected during software installation.
Filter Key?	BaselineWander & Artifact BaselineWander Artifact	Determines which filter combinations are active when <b>Filter</b> key is on.
Auto print speed?	25 mm/sec 50 mm/sec	Default Auto ECG print speed; can be overridden from the front panel.
Default Auto?	3×4 3×4,1R I 3×4,3R I, II, III 6×2	Default format for Auto ECGs. Determines row & column notation for ECG. Rhythm strip leads also selected here ("R" means rhythm strip).
Default Manual?	3 6 12	Default format for Manual ECGs. Selects number of leads on Manual ECG.

Table 2-3. Global Configuration Parameters (continued)

Parameter	Setting Choices	Comments
Leads?	AHA IEC	Selects between two lead standards. Affects lead labels on report.
Custom 3-lead group?	I aVF V2	You can set any combination of the available leads for routine usage. See explanations following this table.
Custom Manual 6?	II aVF V1 V2 V4 V6	You can set any combination of the available leads for routine usage. See explanations following this table.
Units of Measure?	English (lbs/ins) Metric (kg/cm)	Used for height and weight entry. Determines Patient ID units on the ECG.
Print Interpretation? †	Reasons Extend Measure None Severity only†† Choice Measure Interpret	See "Interpretation Parameters" section following this table.
Time format?	AM/PM 24 Hr	
Time separator?	HH:MM:SS HH.MM.SS	
Date format?	MM/DD/YYYY DD/MM/YYYY YYYY/MM/DD	
Date separator?	MM/DD/YYYY MM.DD.YYYY MM-DD-YYYY MM DD YYYY	
Decimal format?	XXX,XXX.XX XXX.XXX,XX	
Paper size?	A (8.5 × 11 in) A4 (210 × 297 mm)	Selects between "A" (8.5×11 in) and metric "A4" (210×297 mm).
Auto Print?	Yes No	Allows or suppresses printing of Auto ECGs (A.02.XX and higher software only).
AutoCopy?	No Yes	See explanation following this table.

Table 2-3. Global Configuration Parameters (continued)

Parameter	Setting Choices	Comments
Copies? (1-5)	Type number between 1 and 5.	If AutoCopy is "Yes," selects number of automatic copies after original recording.
Location code?	Type a 5-character code.	See explanations following this table.
Cart ID?	Type a 4-character code.	See explanations following this table.
Institution Name?	Type name (up to 40 characters).	See explanations following this table.
Confirmation †	<b>PRELIMINARY - MD MUST REVIEW.</b> Type a label up to 30 characters.	
User A label?	Type a label, up to 8 characters.	See explanations following this table.
User B label?	Type a label, up to 8 characters.	See explanations following this table.
Battery timeout?	Type minutes between 3 and 999.	See explanations following this table.
Set keyboard?	lower UPPER	
Special applications?	No Yes	Allows configuration of research leads, ECG storage mode, and lead system. See the <i>PageWriter XLi Physician's Guide</i> for more information.
Research leads? *	No Yes	Allows 4 additional unipolar leads of user's choice.
Default Adult Criteria? *†	08 P4	08 is the adult analysis criteria; P4 is the pediatric analysis criteria.
Default Pediatric Criteria? *†	P4 08	
ID criteria version entry? *#	No Yes	Yes causes "Criteria Version?" prompt to appear during patient ID entry. Allows use of criteria residing on ECG Management System.
Default ID criteria version?#	User-defined - 2 characters.	Appears only if "ID criteria version entry?" is yes.
ECG storage mode?# *	Standard (250 samples/sec) Special (500 samples/sec)	Special allows ECGs to be measured and interpreted on an M1700A.
Lead system? *	Standard Cabrera	If available.
Power-on application?	XLi Prev+ SAECG	Allows your cardiograph to start up in the selected application (appears with A.02.XX and higher software only).
Password?	User-defined (up to 8 characters).	

\* This parameter appears only if "Special Applications" is set to "yes."

† This parameter appears only on the M1700A cardiograph.

- # This parameter does not appear on the M1702A cardiograph.
- † This parameter appears on A.03.XX software only.

### Interpretation Parameters

These parameters determine the amount of information included in an Auto ECG report.

- **Initial Interpretation** controls the information that appears on the ECG when it is first taken.
- **Copy Interpretation** controls the information that appears on subsequent copies of the ECG.
- **Print Interpretation** controls the information that appears on a printout of a stored ECG.

Each setting choice adds another piece of information to the printed ECG. The settings' definitions are:

None	Prints waveform and patient ID.
Severity only	(A.03.XX only) Prints waveform, ID, and severity.
Measure	Prints waveform, ID, and measurements summary.
Interpret	Prints waveform, ID, measurements summary, and computer-generated interpretation.
Reasons	Prints waveform, ID, measurements summary, computer-generated interpretation, and interpretive reason statements.
Extend Measure	Prints a tabular summary of all measurements performed on ECG data. An alternative report.
Choice	Allows you to select the level of information included when an ECG is copied or printed from disk without having to change the overall instrument configuration.

### Power-on Application (M1755A A.02.XX and Higher Software Only)

To select which application (XLI, Preview Plus, or SAECG) the PageWriter will start up with, set the "Power on application" parameter to that application.

### Line Frequency

This parameter selects the frequency of the filter enabled by the line power filter. The user usually selects the frequency in response to a prompt from the system during initial installation. However, the system will not prompt for a frequency selection when a custom configuration is loaded. Including this parameter in Global configuration allows the user to change the frequency selection after initial software installation.

### Custom Lead Groups

Besides the pre-defined lead groups, you can configure one group of three leads and one group of six leads that may be selected for Auto 3×4,3R, Manual 3 or Manual 6 reports. These lead groups will appear and be recorded when you select Custom 3-lead group and Manual 6-lead reports from the main display.

1. Configure custom lead groups from global configuration when the display as shown below appears.

Custom 3 lead group	I aVF V2
Enter      Choose      Tab	Previous      Exit

2. Press **Choose** to change the lead from I.
3. Use **Tab** to move to the next lead field. In this case, the next lead field is aVF.
4. Press **Choose** in each field to change the lead setting.
5. Press **Enter** to save the selections.

### AutoCopy

When AutoCopy is set to Yes, the cardiograph automatically prints one or more copies (depending on "Copies" parameter setting) of the Auto ECG after the original is recorded. When AutoCopy is set to No, you must press **Copy** to receive an additional printed copy.

### ECG Management Parameters

These parameters trigger processing protocols on the ECG management system, and provide information for ECG tracking. These parameters include:

Location code	A user-defined numeric code limited to five digits. The first three digits represent the institution and the last two characters represent the department. It can be used to identify the origin of the ECG, such as ER, ICU, CCU, or the department number.
Cart ID	A user-defined code limited to four digits. Identifies the cardiograph to the ECG management system.
Institution Name	Identifies the institution, such as "Sharon General Hospital." Limited to 40 characters.
Confirmation	A label that appears on ECGs. Can be the default label (see table) or user-defined, such as "MD signature X_____." Limited to 30 characters. Available only on the M1700A.
User A label User B label	Enter user-defined label such as "Smoker?" or "Apnea?" that appears in ID entry process. Limited to eight characters.

### Battery Timeout

To lengthen battery life, the cardiograph turns off after the period of time specified by this parameter. The time is measured in minutes from the completion of the last operation, the last key press, or disconnection of patient leads. The time-out function is disabled when the cardiograph is plugged into AC and the AC switch is on.

### Password

To protect your configuration settings from casual changes, you can require password entry to access the configuration. This password is set in Global configuration.

### Caution



---

If the password is set and forgotten, you will be unable to change the cardiograph configuration without reinstalling the factory software.

---

## ID Configuration

When you press **ID** from the configuration menu a parameter selection display appears. The following list presents each ID configuration option. You choose either **Yes** to include or **No** to exclude that item from the patient ID information prompted for while entering patient ID. **Yes** is the default choice for all except the last three items.

- Allow NAME entry?
- Allow AGE entry?
- Allow SEX entry?
- Allow HEIGHT entry?
- Allow WEIGHT entry?
- Allow BP entry?
- Allow RACE entry?
- Allow DX entry?
- Allow RX entry?
- Allow OPERATOR entry?
- Allow DEPARTMENT entry?
- Allow ROOM entry?
- Allow REQUESTED BY entry?
- Allow USER A entry? (“USER A” is replaced by the label defined in global configuration.)
- Allow USER B entry? (“USER B” is replaced by the label defined in global configuration.)
- Allow STAT ECG entry? (Instructs ECG Management System to process this ECG first. M1700A only.)

## Transmit Configuration

When you press **Transmit**, the "Configure" menu for transmit appears in the display.

### Note



The transmit information in this section applies only to the M1700A cardiograph.

```
          Configure
Transmit  Receive  AutoDial          Exit
```

The following list briefly describes the function of each menu selection. A detailed discussion of each selection follows the list.

- Transmit**      Use this key to configure the cardiograph for four transmission sites.
- Receive**      Use this key to select the receive connection type and its baud rate.
- AutoDial**     Use this key to select a site to which the cardiograph automatically sends an ECG when you transmit.
- Exit**         Returns you to the previous menu.

### Transmit

The **Transmit** key brings the Configure Site menu to the display:

```
          Configure Site
          1          2          3          4          Exit
```

When you select a site number, a parameter selection display appears. Table 2-4 lists each parameter and the settings available. The default setting for each parameter is shown in **boldface type**.

Table 2-4. Site Transmission Configuration

Parameter	Setting Choices	Comments
Connection?	None Direct Programmable Modem Hardware Modem Fax programmable modem LaserJet	Hard wire connection to receiver. The Hayes® M1700A modem. Not supported. A.02.XX and higher software only. A.03.XX software only.
Baud Rate?	9600 19200 300 1200 2400	Defaults: 9600 for Direct, 2400 for Programmable Modem and Fax Programmable Modem, 1200 for Hardware Modem, and 19200 for LaserJet. This parameter does not appear if you select <b>None</b> as the connection type.
Phone number? *	(Blank field)	Type phone number, 36 characters max. See explanation following this table.
Dial Type? *	Tone Pulse	Tone is for audio tone dialing, pulse is for rotary dial system.
Pause Length? Seconds *	2, 4, 6, 8, 10 (secs)	See explanation following this table.
Print grid on report?†	Yes No	A.03.XX software only

\* This parameter appears only when the Programmable Modem is selected as the connection type.

† This parameter appears only when Fax Programmable Modem or LaserJet is selected as connection type.

**Entering the Phone Number.** When you advance to the phone number parameter, the Phone number? prompt appears on the display followed by an underscore cursor. Two additional softkey labels, **Pause(,)** and **Tone(W)**, also appear. To enter the phone number, type the numerals on the keyboard. The number will appear on the display at the "Phone number?" prompt. The phone number is limited to 36 characters, including tone and pause characters.

The **Pause(,)** softkey inserts pauses (which appear as commas in the display) into the dialing sequence. The pause avoids dialing errors that can occur if the number is sent too rapidly. An example would be 1,234,567,8900. The length of the pause is selected with the pause length parameter.

The **Tone(W)** softkey inserts a tone wait (which appears as a W in the display) into the dialing sequence. The W in the number instructs the modem to wait for a dial tone before completing the dialing sequence. For example, 9W1,234,567,8900 instructs the modem to dial the 9 (for an outside line), then wait for a dial tone before it dials the rest of the number.

If you want to change one of the characters, use the left and right arrow keys, **◀** and **▶**, to move the cursor to the digit you want to change, and type the new number. The new character will replace the old one. Or you can use the backspace key to erase back to the character you want to change, then retype the erased part with any changes you want to make.

### Receive

When you select **Receive**, the parameter selection display appears. The following table lists each parameter and the settings available. The default setting for each parameter is shown in **boldface** type.

**Table 2-5. Site Receive Configuration**

Parameter	Setting Choices	Comments
Connection?	<b>None</b> Direct Programmable Modem Hardware Modem Fax/programmable modem	Hard wire connection to receiver. The Hayes® M1706A modem. Not supported. A.02.XX and higher software only.
Baud Rate?	<b>9600</b> 19200 300 1200 2400	Defaults: 9600 for Direct, 2400 for Programmable Modem and Fax/programmable modem, 1200 for Hardware Modem. This parameter does not appear if you select "None" as the connection type.

### AutoDial

When you select **AutoDial** from the "Configure" menu, the **AutoDial site?** prompt appears in the display. Use the **Choose** softkey to select the site (1, 2, 3, 4, or **None**) that the cardiograph will automatically dial when the operator issues a transmit command.

## LaserJet Printer Configuration (A.03.XX Software Only)

The following table lists the settings to choose to configure the cardiograph to print on a LaserJet printer.

Note



Only ECGs (not SAECGs, VCGs, Store log reports, or configuration reports) can be printed on a LaserJet printer. Only PCL5 LaserJet printers are able to print from a cardiograph.

Table 2-6. LaserJet Printer Configuration

Parameter	Setting Choice
Connection?	LaserJet
Baud Rate?	19200
Print grid on report?	Yes

## Configuration Files

When you press Files (from the main Configuration menu) the following menu appears on the display:

Configuration file jobs		
Store	Print	Exit

- Store** Stores the configured software on disk.
- Print** Prints a copy of the cardiograph configuration.
- Exit** Returns you to the main configuration menu.

Note



Store the configured software each time it is changed. Print a copy of the cardiograph configuration and keep it with the configuration disk. If the software is lost due to loss of battery power, you will be able to easily restore the cardiograph to its latest configuration.

Note



The M1702A can only print its configuration.

### Store

Storing the configured software creates a disk that contains the software, language option, and (on the M1700A only) criteria version as well as the configuration. The disk can then be loaded at power-on to initialize the cardiograph with a known configuration.

When you press **Store**, the prompt "Enter disk label?" appears followed by a blank field. This label, which is optional, can be up to 16 characters long, and is displayed during installation of the software. Examples of labels are "11/90 Config." or "Dr. Jones Disk."

After you type in the name and press **Enter**, the prompt "Insert disk, then press Continue." appears. When you do so, the cardiograph displays "Storing cardiograph configuration..." until the storage is complete. Then "Disk (your label) created." is displayed. Press **Exit** to get back to the main configuration menu.

**Note**



---

With the A.02.XX and higher software and SAECG application installed and configured, both software configurations can be stored on a single flexible disk. This disk can then be used to re-install the A.02.XX or A.03.XX software and SAECG application together.

---

**Note**



---

With the A.03.XX software and VCG application installed and configured, both software configurations can be stored on a single flexible disk. This disk can then be used to re-install the A.03.XX software and VCG application together.

---

#### **Print**

When you press **Print** the cardiograph prints a copy of its configuration settings. The message **Printing cardiograph configuration...** appears on the display until the printout is complete; then you return to the "Configuration file jobs" menu.

## Operation

---

This chapter briefly summarizes the cardiograph's operation. This information is intended for the service person and is not a substitute for the information in the operator's manuals. Refer to one of these manuals for more comprehensive and detailed operating instructions.

- *PageWriter XLi Operating Guide*
- *PageWriter XLi Cardiograph User's Reference*
- *PageWriter XLi Cardiograph Physician's Guide*
- *PageWriter XLs User's Guide*
- *PageWriter XLe User's Guide*

### Note



---

Refer to the appendixes for information on using the SAECG application, the fax modem, and the VCG application. Refer to the end of this chapter for information on using Preview Plus.

---

## The Keyboard and Front Panel

Figure 3-1 shows the keyboard and front panel. Controls and indicators shown are described on the following page.

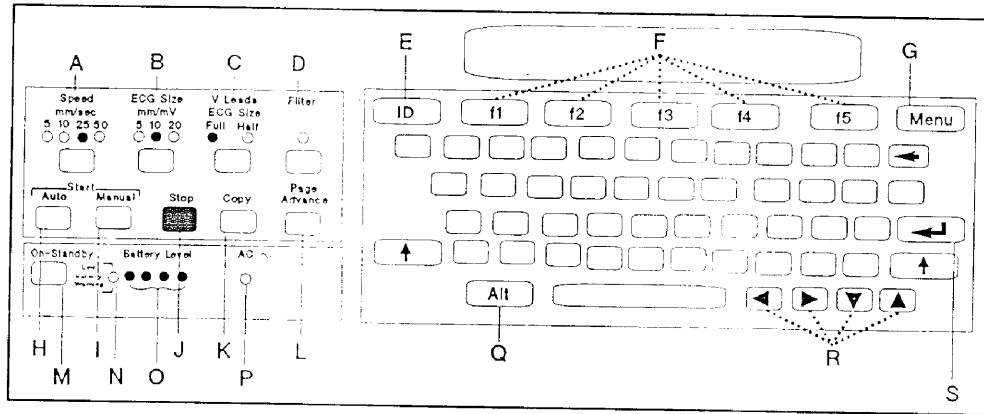











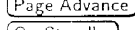
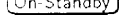









Figure 3-1. The Keyboard and Front Panel.

## 3-2 Operation

A		Changes the paper speed. It switches between 5, 10, 25, and 50 mm/sec for Manual ECGs, and between 25 and 50 mm/sec for Auto ECGs.
B		Changes the limb and chest lead sensitivity between 5, 10, and 20 mm/mV.
C		Changes the chest lead sensitivity between full and half size with respect to the value set by the  key.
D		Turns artifact and baseline wander filters on and off depending on which filter or filters are set in configuration.
E		Allows patient identification entry, review, and edit.
F	softkeys	These five keys (f1 - f5), called "softkeys," appear directly beneath the display window and perform different functions at different times. When a particular f key is active, a label describing its function appears above it in the display window.
G		Changes the softkey selection between two displays.
H		Starts an Auto ECG recording.
I		Starts a Manual ECG recording.
J		Halts any cardiograph function.
K		Prints a copy of an ECG which has just been acquired.
L		Advances the paper to the beginning of the next page.
M		Switches the cardiograph between <b>On</b> and <b>Standby</b> . The cardiograph is not operational when in standby, but it is powered.
N	Low Battery	Light indicates that the cardiograph must be plugged in and recharged.
O	Battery Level	Lights indicate the remaining capacity level of the battery. When the battery is fully charged, all the lights are on. <b>Always check the battery level lights before disconnecting AC power.</b>
P	AC ~	Light will be on when the power cord is plugged into a wall outlet and the AC switch is on. This indicates that the battery is charging. The AC switch is on the back of the cardiograph.
Q		Pressed with  at power on for cardiograph self-test.
R	   	The left and right arrows move the cursor when typing information in data entry fields on the keyboard display. The down and up arrows select leads on Preview Screen.
S		The Enter key.









### Other Operating Controls

There are other operating controls that are not part of the keyboard. The knobs that control preview screen contrast and brightness are on the preview screen front panel (M1700A only). The remote start button, , is located on the patient module (M1700A & M1701A only). The contrast controls for the keyboard display (above the keyboard) and the patient module display are key combinations entered at the keyboard.

### Note



The M1702A patient module does not have a display or a remote start button.

To increase contrast on the keyboard display, press  and ; to decrease contrast, press the  and . To increase contrast on the patient module display, press  and ; to decrease contrast, press  and . You may need to press the arrow keys multiple times to achieve the contrast desired.

## Choosing a Report Format

You can record two types of ECGs:

- Auto ECGs are 1-page, 12-lead ECGs with or without rhythm strips.
- Manual ECGs are continuous tracings of 3, 6, or 12 leads.

In addition, if you have the M1754A SAECG option you can record signal-averaged ECGs. Examples of a few of the ECG types are shown in the figures on the following pages.

To choose a report format, use the softkeys shown in the menu display below. This menu also allows you to set the date and the time (the procedure for setting date and time is described in Chapter 2). If you do not have this or a similar menu in the display, press **Menu** or **Stop** until you do.

### Note



The information displayed in the message line (upper line of the display) depends on the format last chosen. For this reason, your display may be different than the example shown here.

Auto	3x4,3R	I,II,III		
Report	Format	Leads	04/01/1990	02:23:34PM

**Report** Selects between the Auto or Manual report menus.

**Format** Selects the number of leads and the report presentation. The selections are:

Auto Formats	Manual Formats
3x4, 3R	6
6x2	12
3x4	3
3x4, 1R	

### Note



The Auto Formats are in “row by column” format. “R” means rhythm strips.

## Leads

For an Auto report (3×4, 3R and 3×4, 1R only), this key selects the set of leads used for rhythm strips. For a single rhythm strip (1R) you select any one of the twelve leads; the default lead is I. For three rhythm strips (3R), the lead sets available are:

- I, II, III
- aVR, aVL, aVF
- V1, V2, V3
- V4, V5, V6
- Custom (Default = I,aVF,V2)

For a 3- or 6-lead Manual report, this key selects the set of leads used (12-lead reports automatically use all 12 leads). The selections for the 3-lead set are the same as for the 3R sets listed above. The selections for 6-lead sets are:

- I, II, III, aVR, aVL, aVF
- V1, V2, V3, V4, V5, V6
- Custom (Default = II,aVF,V1,V2,V4,V6)

## Note



---

You can change power-on default leads in Global Configuration.

The lead selections listed above are for the Standard configuration. If the cardiograph is configured for Cabrera leads, the lead selections that appear will be different. Also, if pediatric, Frank, or research leads are connected in place of standard leads, the cardiograph detects their presence and alters the displayed lead sets accordingly.

---

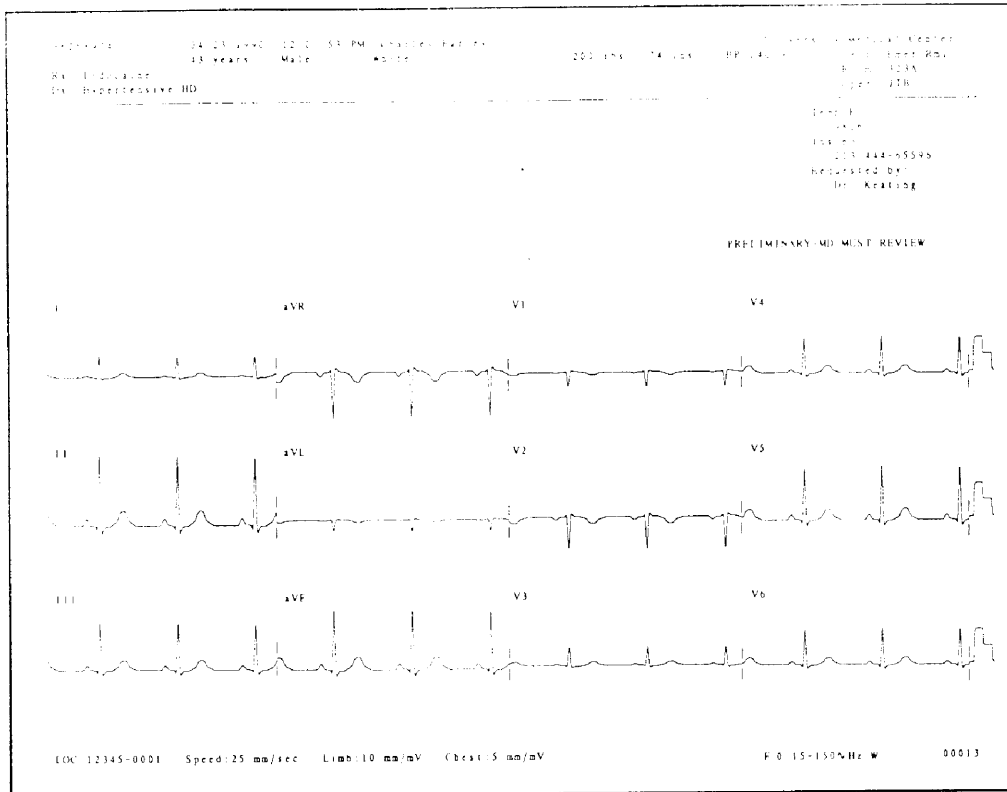

Figure 3-2. An Auto 3x4 ECG (3x4).



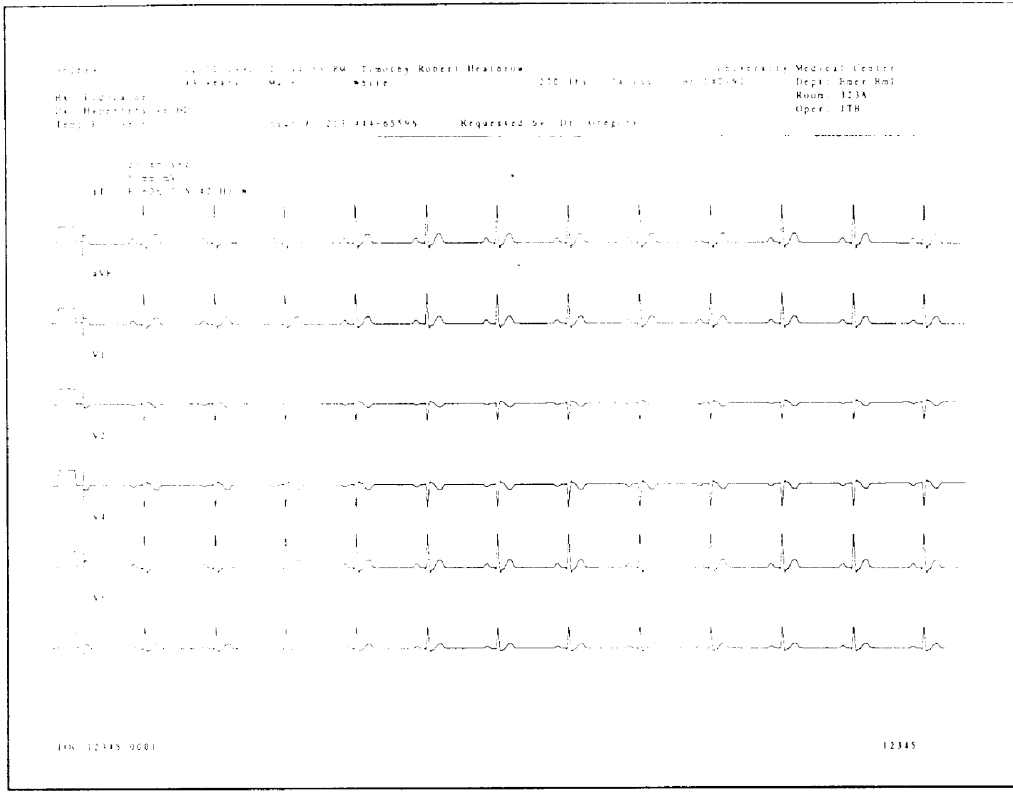

Figure 3-4. A Manual 6-Lead ECG.

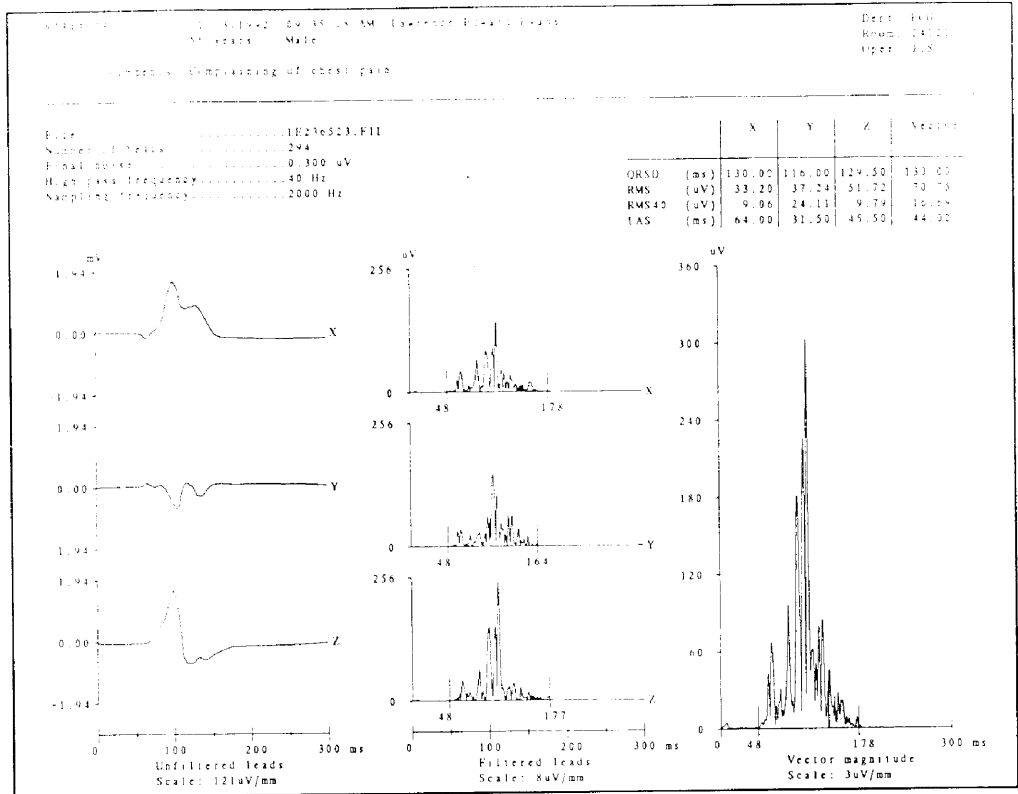

Figure 3-5. An SAECG Report.

---

## Main Functions

This section discusses the cardiograph features and functions that you access from the alternate main menu selected by the **Menu** key.

Note



If you have the A.02.00 software, these functions appear in the XLI application.

To begin, press **Menu** until the following display appears:

```
Transmit   Store   Config   CheckDisk   Files
```

Transmit	Selects stored ECGs for transmission to another site.
Store	Stores the last recorded Auto ECG on disk.
Config	Provides access to the cardiograph's operating parameters. Refer to Chapter 2.
CheckDisk	Checks the disk and reports how much storage capacity is in use.
Files	Provides access to the stored files for ID editing, printing, analyzing (M1700A only), or deleting.

These functions are described in the following pages.

Note



The **Transmit** softkey appears only on the M1700A.

Note



The M1702A **Menu** key brings up the following menu:

```
Configuration
Global   ID           Print   Exit
```

Global	Provides access to the cardiograph's operating parameters. Refer to Chapter 2.
ID	Provides access to the cardiograph's operating parameters. Refer to Chapter 2.
Print	Prints the cardiograph configuration.
Exit	Returns to the main menu.

Transmit (M1700A Only) When you press **Transmit**, the following menu is displayed:

Transmit				
Selected	All	NewGroup	Query	Exit

**Selected** Presents the selection display (the selection display is described at the end of this section). Allows you to select one or more stored ECGs for transmission. If AutoDial is enabled, the cardiograph automatically dials and transmits the selected ECG(s) to the chosen site when you press **Transmit** in the selection display.

**All** Transmits all the stored ECGs. If AutoDial is enabled, the cardiograph dials and transmits immediately. If AutoDial is not enabled, the following display appears:

Choose Site				
1	2	3	4	Manual

Selecting one of the numbers initiates transmitting to the site assigned to that number. If you select **Manual**, the display prompts you to enter configuration information. Refer to Chapter 2 for details about configuring autodial sites.

**NewGroup** Transmits only those ECGs that have not previously been transmitted.

**Query** Calls a site to receive ECG information. Query is used only with an ECG management system. The PageWriter can receive ECGs from an ECG management system on request by using the Query function. PageWriters with A.01.XX software can only receive text information this way, and cannot receive ECG traces.

**Note**



The PageWriter provides two types of Query: standard and interactive (interactive query is only available with A.02.XX software).

In standard query text reports (analysis only) are queued at the system for output to the cardiograph. Only diagnostic and extended measurement reports can be sent in standard query.

In interactive query, the cardiograph user selects the ECG to receive. A single patient's ECG (report and waveform) can be retrieved from the system this way by answering yes to the question **Select an on-line report**.

Note



---

Revision A.02.XX software enables the M1700A to transmit Auto ECGs to the F.A.A. ECG management system.

---

Exit Returns you to the previous menu.

**Store**  
(M1700A & M1701A only)

This key stores the current Auto ECG on the disk (Manual ECGs cannot be stored). An ECG must have a patient ID number before it can be stored. If the ECG to be stored has no patient ID when you attempt to store it, the cardiograph asks if you want to give it one. If your answer is "No," the cardiograph aborts the store attempt and returns you to the alternate main menu. If your answer is "Yes," the cardiograph takes you through the patient ID entry process as if you pressed the **ID** key on the front panel.

Once you enter a patient ID and exit the patient ID entry process, the cardiograph stores the ECG on the disk. The message **Storing ECG** appears while the ECG is being stored. Then the display returns to the main menu.

If the disk you inserted in the drive is new and unformatted, the cardiograph will ask if you want the disk formatted. Press **Yes** if you do (formatting takes about 90 seconds), or insert a formatted disk in the drive at this time. A disk must be formatted for storage to take place.

Note



---

The A.02.XX software allows you to erase (reformat) flexible disks by using **CheckDisk** (see below).

---

**Config**

This function allows you to configure the PageWriter. See Chapter 2 for details.

**CheckDisk**  
(M1700A & M1701A only)

#### **A.01.XX Software**

With the A.01.XX software, CheckDisk allows you to determine how much storage capacity remains on the disk. When you press **CheckDisk**, a message similar to the following appears in the display:

Disk 25% full

#### **A.02.XX Software**

The A.02.XX software enables CheckDisk to reformat flexible disks as well as determine how much storage space is available on the disk.

When you press **CheckDisk**, the message **Reading the disk...** appears, followed by a second message that shows the percentage of storage space available on the flexible disk. For example, you may see a message such as:

```
Disk 25% full.
      Erase           Exit
```

If you want to reformat the disk, press **Erase**.

**Files**  
**(M1700A & M1701A only)**

This key gives you access to several functions that allow you to manipulate the stored ECGs in a variety of ways. When you press this key, this menu appears:

```
Delete   Log     Edit   Print   Analyze
```

**Delete** Allows you to delete stored ECGs. This key brings up the selection display (the selection display is described at the end of this section). After you select the patient ID numbers for the ECGs that you want to delete, press the **Delete** softkey in the selection display. The cardiograph displays the question **Start Deleting 1 ECG(s)?** (The number "1" will vary in all messages depending on how many ECGs were selected.) Press **Yes** if you want to continue. The message **Deleting 1 of 1 ECG(s)** appears and the ECG is removed from the disk. The following display appears to confirm that the ECG is deleted. Press **Exit** to continue.

```
1 ECG(s) deleted
                               Exit
```

**Log** Prints the ECG-Log or Store-Log. The cardiograph prompts you to select before printing.

The ECG-Log is a list of the last 60 Auto and Manual ECGs recorded on the cardiograph. It shows the time and date the ECGs were recorded and if they were stored. The Store-Log lists all Auto ECGs stored on the flexible disk currently in the disk drive. It shows if ECGs on the disk were transmitted, analyzed, or edited.

**Edit** Enables you to edit the patient ID information on stored ECGs when you press the **Edit** key on the selection display. The cardiograph displays the patient ID information for editing just as it does when you press the **(ID)** key on the front panel.

When you finish editing, the cardiograph offers to store the ECG on the disk. When the storage is complete or if you press **No**, the alternate main menu returns to the display.

**Note**



---

On the M1700A only: when you finish editing, the cardiograph offers to analyze the ECG again. When this analysis is complete (or if you decline analysis), *then* the cardiograph offers to store the ECG.

---

**Print** Prints the selected ECG(s) when you press **Print** on the selection display menu (the selection display menu is described at the end of this section). While the ECG is printing this message is displayed:

**Printing 1 of 1 ECG(s).**

When the printout is done, this message is displayed:

**Printed 1 ECG(s).**

**Analyze** **This function is available only on the M1700A.** Analyzes the selected ECGs when you press **Analyze** on the selection display menu. Also provides the option of printing the analyzed ECG(s). While the cardiograph analyzes the ECG(s), these messages appear:

**Reading 1 of 1 ECG(s).**  
**Analyzing 1 of 1 ECG(s).**  
**Storing 1 of 1 ECG(s).**

When complete, the cardiograph displays

**Analyzed 1 ECG(s).**

Choose **Exit** to return to the alternate main menu.

## The Selection Display (M1700A & M1701A only)

The selection display is a two-part menu that allows you to select patient ID numbers of stored ECGs for operations such as transmitting, editing, deleting, printing, and analyzing.

### Selection Display Menu, Part 1

The first part is a display similar to the menu shown here.

123456			04-01-90	11:25:51AM
Select	<i>Function</i>	Next	Previous	More

- Select** Selects the patient ID number displayed in the message line. An asterisk (\*) appears before the entry to indicate its selection. If the number is already selected, pressing this key de-selects the number. As you move through the list of stored ECGs, you can select any number of ECGs (except in the edit function, which allows only one selection).
- Function** Starts the function for which you are selecting an ECG. This key has one of the following function names:
- Transmit (appears only on the M1700A)
  - Delete
  - Analyze (appears only on the M1700A)
  - Edit (allows only a single ECG selection)
  - Print
- Next** Steps forward through the list of stored ECGs.
- Previous** Steps backward through the list of stored ECGs.
- More** Displays the second part of the selection display menu, shown in the next section.

### Selection Display Menu, Part 2

The second part of the selection display menu is similar to this one.

123456			04-01-90	11:25:51AM
	<i>Function</i>	All	Find	More

- Function** The function label appears in both menu parts for convenience. You can initiate the function without toggling to the other part of the menu.
- All** Selects all stored ECGs. (Not available with Edit.)
- Find** Selects a specific ECG—you enter the number.
- More** Switches to the first part of the menu.

---

## Recording an ECG

To record an Auto ECG:

1. Press **Auto** on the front panel.

Note



Your cardiograph may be configured to automatically request patient ID each time you start an ECG. To override the request for patient ID, press **Auto** again.

---

- If you entered the current patient's ID before you pushed the **Auto** key, the ECG will be recorded without further prompts.
  - If you have not recorded an ECG since turning on the cardiograph, the message **No ID# entered. Continue?** will appear. Press **Yes** to record the ECG without ID. Press **No** to start entering patient ID.
  - If you have recorded an ECG since the cardiograph was turned on, the question **Continue using ID#?** appears.
    - Press **Yes** if you have entered a patient identification number and want to take more ECGs from the same patient.
    - Press **No** if you are recording an ECG from another patient.
2. The status messages **Acquiring ECG**, a signal quality message (M1700A only), and **Printing Auto Report** appear. If you have not yet entered the patient ID yet and AutoStore has been turned on during configuration, the message **ID required to store. Store ECG?** appears. Pressing **Yes** takes you through ID entry before storing the ECG; pressing **No** aborts the storage.

Note



ECG interpretation is a feature of the M1700A only, and depending on the configuration, electronic interpretive information may be prevented from appearing on the printed copy. Refer to the configuration information in Chapter 2 (see Initial, Copy, and Print Interpretation).

---

To record a Manual ECG, press **Manual** on the front panel. The status message **Printing Manual Report** appears. The cardiograph will print the ECG continuously until you press the **Stop** key or the  on the patient module.

You cannot store a Manual report.

---

Note



Your cardiograph may be configured to request patient ID automatically each time you start an ECG. To override the request for patient ID, press **Manual** again.

---

- Reformat** Reformats a stored 500 sample/second ECG for printing using a format and features you select. To reformat a stored ECG, insert the ECG storage disk in the cardiograph and press **Reformat**. A selection display appears, and you can select an ECG to reformat. Once you select the ECG, a screen appears that allows you to select the format and features you want. Press **Print** to print the reformatted ECG. You cannot store a reformatted ECG. It will be stored in the format in which it was originally recorded.
- Timed** Enables you to record an ECG automatically at regular intervals. To do this, press **Timed**. The message **Interval in minutes? (1 - 20)** appears. Enter the interval at which you wish the cardiograph to record Auto ECGs, then press **Enter**. Press **(Alt)** and **(F2)** to begin the series of Auto ECGs. An ECG will be recorded immediately and at each interval thereafter. Press **(Stop)** when you want to stop recording ECGs.
- ContPrev** Lets you monitor a patient's ECG continuously on the preview screen, even when printing an ECG. To turn on the Continuous Preview application, press **ContPrev**. The message **Continuous Preview On?** appears. Press **Yes**. To turn off Continuous Preview, press **ContPrev** again. When the message **Continuous Preview On?** appears, press **No**.
- Delayed** Prints ECG information six seconds after the PageWriter receives it. This allows you to capture waveform information currently displayed on the preview screen. To set your cardiograph for recording a delayed Manual ECG, press **Delayed**. The message **6-Second Delayed Manual?** appears. Press **Yes** and the cardiograph will begin to save ECG information. When you see an ECG sample that you wish to print, press **(Manual)**. Press **(Stop)** to stop the printing. To return to non-delayed ECG mode, press **Delayed** again. When the message **6-Second Delay Manual?** appears, press **No**.

**Note**



---

You can also configure the PageWriter to use Preview PLUS as its Power-On application. See "Power-On Application" in Chapter 2 for more information.

---



## Performance Verification and Maintenance

---

### Introduction

This chapter describes how you verify the cardiograph's performance, explains preventive maintenance, presents patient safety information, and provides a performance verification checklist.

---

### Performance Verification

Three procedures make up performance verification: visual inspection of the cardiograph exterior, execution of Extended Self-test, and visual examination of an ECG recorded from an ECG patient simulator.

The performance verification checklist at the end of this chapter summarizes the steps you should follow to verify the cardiograph's performance. These are some suggested uses for this checklist:

- Make copies of the blank checklist, then fill out a copy each time the cardiograph is tested.
- Attach the printer test output, simulator ECG trace, and error log printout to the completed checklist and file with the cardiograph's permanent maintenance record.

### Visual Inspection

Before beginning the inspection, press the **On-Standby** key to put the cardiograph in **Standby**, and unplug the power cord from the wall outlet. Then inspect the cardiograph for the following:

- Worn or damaged power cord
- Loose or missing hardware
- Mechanical damage
- Evidence of liquid spill
- Worn printer drive gear
- Worn printer roller
- Corroded or damaged electrodes
- Worn or damaged patient module cable
- Dirt on the thermal printhead

Replace any damaged or missing items, and clean the printhead and patient electrodes as necessary. Cleaning instructions are listed under "Preventive Maintenance" later in this chapter. Connect the cardiograph to AC power and turn on the AC switch. Observe that the AC indicator comes on. Turn the cardiograph **On** and observe that one or more of the battery indicators light.

## Extended Self-test

The cardiograph's Extended Self-test, loaded as part of the system software, tests each major subassembly. The display tests and the printer test require visual verification of displayed or printed output.

In most cases, a test failure halts the test and a message indicating the failure appears on the keyboard display. In the case of the tests that require visual verification, visible failure symptoms appear in the printed or displayed test pattern. See Chapter 6, "Troubleshooting," for a list of self-test failure messages and failure symptoms.

To begin the Extended Self-test, press **On-Standby** to turn on the cardiograph, then quickly press and release the **Alt** and **x** keys simultaneously. The following display will appear:

```
Test: All
Select   Test   Next   Previous  ErrorLog
```

The upper line displays the test choice, while the lower line displays the softkey labels. With the softkeys you step through the test menu, select tests, and initiate testing.

Select	Selects the test displayed in the message line. Asterisks (*) appear around the test name to indicate its selection. If the test is already selected, pressing this key de-selects the test (the asterisks disappear). You can select one or more tests in any combination, but the sequence is fixed.
Test	Begins running the selected test(s).
Next	Steps forward through the test menu.
Previous	Steps backward through the test menu.
ErrorLog	Prints out the stored error log.

To stop or exit Extended Self-test, you must press **On-Standby** to place the cardiograph in **Standby**.

These are the tests available in Extended Self-test:

- Patient module and cable
- CPU assembly
- Printer
- Disk drive (M1700A and M1701A only)
- Preview display (M1700A only)
- Keyboard display
- Modem and cable (M1700A only)
- All

Each test in this list is described in more detail in the discussions that follow.

To begin running the tests you press **Test**. The test or tests that you selected then run continuously until you stop the Extended Self-test. After each successful pass through the tests, the number in the message **Selected tests passed *nnn* times.** increases by one. To stop the Extended Self-test, you must place the cardiograph in Standby.

#### **Patient Module and Cable Test**

This test looks for failures in the patient module and patient data cable, and generates a test pattern in the patient module display.

If the patient module fails the test, the message **Patient module test failed.** appears on the keyboard display. If the cable fails the test, the message **Patient module cable test failed.** appears.

#### **Note**



The patient module test does not test the patient electrodes or leadwires. Test the patient electrodes and leadwires by recording an ECG from a patient or ECG simulator as described later in this section.

#### **Note**



The M1702A patient module does not have a display.

The test patterns displayed on the patient module consist of (in this order):

- all white cells
- checkerboard cells
- all black cells
- inverse checkerboard cells
- 80 characters (displayed in 5 successive groups of 16)
- all white cells

You must observe the patient module display while the test pattern is running to ensure:

- accurate rendition of all patterns and characters
- no random lines or dots are displayed

Before and after the tests, asterisks appear in the display.

#### **CPU Assembly Test**

This test looks for failures in the following CPU assembly subsystems:

- Real-time Clock
- Printer Controller
- Read-Only Memory (ROM)
- Random Access Memory (RAM)
- Digital Signal Processor (DSP)
- DSP RAM

If the CPU assembly fails the test, the message `CPU assembly test failed.` appears on the keyboard display.

**Note**



The printer door must be closed to properly test the CPU assembly.

**Printer Test**

The printer test exercises the printhead and paper drive mechanism by printing a test pattern on the page four times, once for each printer speed. The pattern consists of a rectangular box that contains the entire character font, a column of numbers, and a black & white pattern. While the test patterns are printing, the message `Printing test pattern ...` appears in the keyboard display.

When the printout is complete, inspect it for:

- straight diagonal lines
- consistent print quality for all four patterns
- constant width for all four patterns
- visible separation between the close parallel lines
- accurate rendition of all characters
- clean black bars with no dropout in black areas
- perforation aligned with tear bar

If the printer assembly fails the test (not including the visual verification of the printout), the message `Printer test failed.` appears on the keyboard display.

**Disk Drive Test (M1700A and M1701A only)**

**Caution**



This test destroys any data previously recorded on the disk. Be sure that any data on the disk is expendable, or use a blank disk.

The disk drive test formats, writes to, and reads from a disk installed in the drive. When you select the disk drive test, the following display appears requesting confirmation of the selection:

Disk test destroys disk data. Select?	
Yes	No

Yes                      Allows the test to be selected.

No                        Prevents the test from being selected.

**Suggestion**



Clearly label and set aside a test disk to help avoid the possibility of accidentally destroying valuable data.

If the disk drive fails the test, the message `Disk drive test failed.` appears on the keyboard display.

Note



---

The disk drive test will fail if the disk is write protected, or if the test is started when there is no disk in the drive.

---

**Preview Display Test (M1700A Only)**

The preview display test checks the preview logic board by writing data to and reading data from the board. This test also displays test patterns on the preview screen. Each of the following patterns appears on the screen for several seconds and in this order:

- checkerboard pattern
- inverse checkerboard pattern
- all black screen
- vertical white bar moving left to right
- horizontal white bar moving top to bottom
- all white screen
- horizontal black bar moving bottom to top
- vertical black bar moving right to left
- all black screen
- text characters in a white box on the black screen

The message `Displaying test pattern ...` appears on the keyboard display during the time the test pattern is on the preview screen.

You must observe the preview screen while the test pattern is running to ensure:

- accurate rendition of all characters and patterns
- no random lines or dots in the display
- no permanent patterns visible at normal contrast. Patterns may be visible at low contrast (darker screen); this is normal.
- no LCD flickering

If the preview display fails the test or if the test is run when a preview display is not installed on the M1700A, the message `Preview test failed.` appears on the keyboard display.

Note



---

If the M1700A is not equipped with a preview display, selecting the preview display test results in a test failure. If you have selected the "All" test choice, remove the preview display test from the selected tests to avoid an erroneous test failure.

---

### Keyboard Display Test

The keyboard display test exercises each cell in the LCD by displaying the following patterns:

- checkerboard cells
- all black cells
- inverse checkerboard cells
- all white cells
- text characters

You must observe the keyboard display while the test pattern is running to ensure:

- accurate rendition of all characters and patterns
- no random lines or dots in the display
- no permanent patterns visible at normal contrast. Patterns may be visible at low contrast (darker screen); this is normal.
- no LCD flickering

This test relies on the visual inspection of the test patterns for detecting failures. There is no failure message for the keyboard display test.

### Modem Test (M1700A Only)

The modem test checks the operation of the Hayes® modem and its connecting cable.

#### Note



---

The cardiograph must be connected to AC power to operate the Hayes® modem.

---

If the modem passes the test, the message **Modem firmware checksum: xxx.** appears. If the modem fails the test, or if the test is run when a modem is not installed on the M1700A, the message **Modem test failed.** appears on the keyboard display.

#### Note



---

If the M1700A is not equipped with a modem, selecting the modem test results in a test failure. If you have selected the “All” test choice, remove the modem test from the selected tests to avoid an erroneous test failure.

---

### All Tests

The "All" test choice allows you to select all the tests with one keystroke. Then when you press **Test**, Extended Self-test continuously runs all of the individual tests in sequence. At the end of each successful pass through the test sequence, the number in the message **Selected tests passed *mmn* times.** is increased by one. If one of the selected tests fails, testing stops and the failure message for the failed test is displayed until the cardiograph is placed in **Standby** or shuts off due to a low battery.

Before you press **Test** to start the "All" selection, delete any tests that would cause a false failure indication. The tests that fall into this category are:

- the disk drive test (M1700A and M1701A only)—delete if you do not have a disk suitable for testing. Testing the disk drive with a write protected disk or without a disk installed will cause the test to fail.
- the preview display test (M1700A only)—delete if the M1700A does not have a preview display installed. The test will fail if a preview display is not installed.
- the modem test (M1700A only)—delete if the M1700A does not have a modem installed. The test will fail if a modem is not installed.

If you want to delete one or more of these tests after selecting "All," you can move through the list and press **Select** to remove any test from those selected. When you delete a test, the asterisks disappear from around the test name in the display.

### Printing the Error Log

As errors occur, they are stored in memory in the error log. Pressing the **ErrorLog** softkey prints the stored error log. While the error log is printing, the message **Printing error log ...** appears on the keyboard display. When the printout is complete, you can select another test from the Extended Self-test menu.

To understand the error printout, refer to the error lists in Chapter 6, "Troubleshooting." Store the error log printout with the cardiograph's permanent maintenance record.

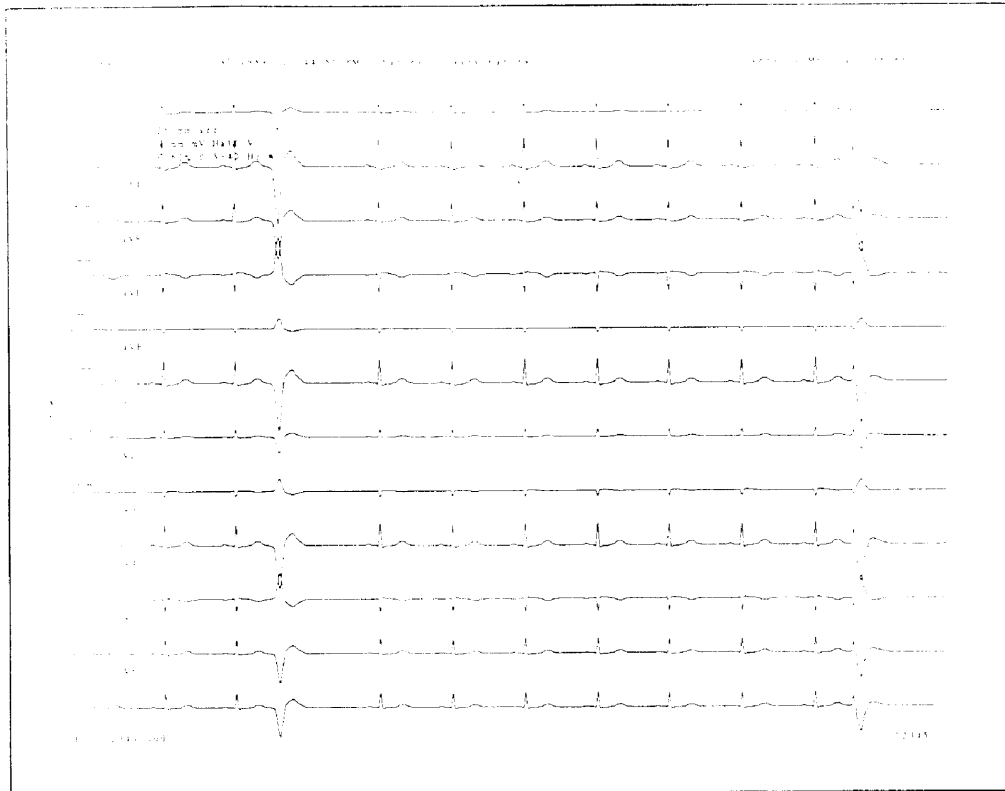

**Figure 4-1. 12-Lead ECG from ECG Simulator.**

**ECG Simulation** Taking an ECG using a 12-lead ECG simulator allows you to verify areas of operation that Extended Self-test cannot test:

- the integrity of the patient module leadwires
- the accuracy of the paper speed
- the accuracy of the gain settings

The recorded ECG trace should look similar to the one shown in Figure 4-1, although there will probably be differences in the trace you record. The trace differences result from differences in simulators, simulator settings, and, more importantly, from differences in configuration and control settings on the cardiograph. To make a recording similar to the one in Figure 4-1:

1. Connect the patient module leadwires to the simulator. Check the display on the patient module to verify that all leadwires are connected and signal quality is adequate. Gently pull each leadwire taut and look for excessive noise on the patient module display.
2. On an M1700A with preview display, check that all twelve leads are displayed. The leads will be displayed in groups of three.

3. Select a Manual format on the front panel display (preferably 12 leads).
4. Press **Manual** on the cardiograph front panel (or press  on the patient module) to start the recording.

When the recording is complete:

- Verify trace activity for all 12 leads. This assures integrity of all patient electrodes and leadwires. Noise should measure less than 1 mm, and there should be no baseline wander.
- Verify no gross distortion of complexes or calibration pulses (no overshoot, etc.).
- Verify that calibration pulses are of proper duration. This assures the correct paper speed. With the cardiograph set to record at 25 mm/sec, the calibration pulse should measure 5 mm (calibration pulse duration is 200 ms).
- Verify that calibration pulse amplitude is correct. This assures the correct gain. With the cardiograph gain set at 10 mm/mV, the calibration pulse should measure 10 mm (calibration pulse amplitude is 1 mV).

**Note**



An arrhythmia simulator is not an acceptable tool for verifying computerized ECG analysis. The analysis software is biased to process human ECG data.

**Note**



SAECG verification should not be required in addition to standard ECG simulation. However, you can use an ECG simulator to determine that the SAECG is functional. All leadwires should be connected to the simulator (though you do not need to connect specific leadwires to specific outputs). See Chapter 3 for more information.

## Preventive Maintenance

Routine maintenance for the cardiograph consists mainly of cleaning and inspection.

**Caution**



The cardiograph does not require any kind of lubrication. Lubricating any part of the cardiograph could damage it or diminish its performance.

## Care and Cleaning

The cardiograph and its accessories are chemically resistant to common cleaning solutions and non-caustic detergents. The following are some approved cleaning solutions for all of the outside surfaces of the cardiograph, the patient module, and the cart.

- Mild soap and water
- Chlorine Bleach (30ml/l water)
- 90% Isopropyl Alcohol

If the keyboard requires cleaning, you can remove it from the cardiograph and immerse it in lukewarm water.

### Cleaning the Cardiograph and Patient Module

1. Unplug the power cord and ensure that the cardiograph is set to Standby at the front panel.
2. Wipe the external surfaces of the cardiograph, the patient module, and reusable electrodes with a soft cloth dampened in any of the approved cleaning solutions listed above. Avoid the leadwire inputs and cable connections.

## Caution



---

Do not use any strong solvents or abrasive cleaning materials.

Do not spill any liquids on the surface of the cardiograph.

Do not immerse the patient module.

Do not use any of the following to clean the cardiograph:

- Ammonia-based cleaners
  - Acetone
  - Iodine-based cleaners
  - Phenol-based cleaners
  - Ethylene oxide sterilization (ETO)
  - Autoclave
- 

### Cleaning the Keyboard

1. Carefully insert a small flat-bladed screwdriver into the notches at the top or bottom edge of the keyboard and pry the keyboard up.
2. Rinse off the keyboard and thoroughly dry it.
3. Snap it back into the cardiograph.

## Caution



---

Do not wash the keyboard in hot water. Do not attempt to clean the keyboard in a dishwasher.

---

### Cleaning the Printhead and Paper Sensor

If you use Hewlett-Packard recording paper, you should not have to clean the printhead for the life of the product. Should you decide to do so, this is the procedure to follow. These are the materials required:

- Foam swabs—Hewlett-Packard part number 9310-0468 or 9300-0767
- 90% Isopropyl Alcohol—Hewlett-Packard part number 8500-0559 or equivalent
- Dry, lint-free tissue—Kinwipes® or Hewlett-Packard lint-free wipes (Hewlett-Packard part number 92193W)

To clean the printhead:

1. From the front of the cardiograph, unlatch and open the paper door. The printhead is to the right under the paper blade, behind the ESD brush (see Figure 4-2).
2. Scrub the printhead with a foam swab moistened with isopropyl alcohol.
3. Dry the printhead with a lint-free tissue.

To clean the paper sensor lens:

1. From the front of the cardiograph, unlatch and open the paper door. The paper sensor lens is to the right under the printhead (see Figure 4-2).
2. Lightly wipe the paper dust off of the paper sensor lens with a dry foam swab.

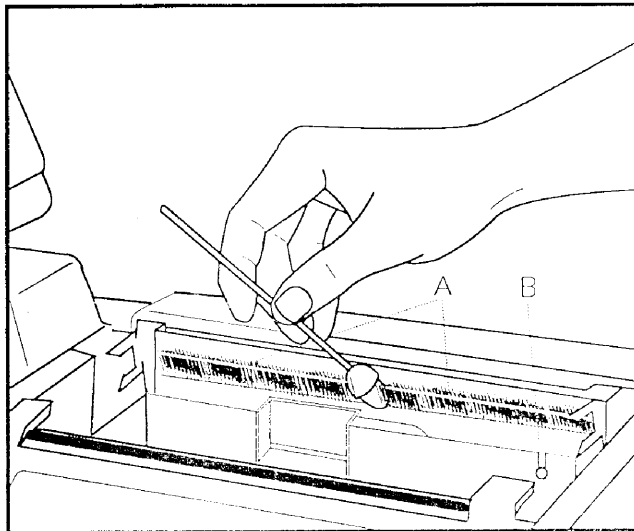

Figure 4-2. Cleaning the Digital Array Printhead.

- A. Printhead
- B. Paper Sensor

### Maintaining the Flexible Disk Drive

Follow these rules to keep your flexible disks and their stored files in good condition.

- Never manually open the silver shutter on the disk.
- Do not expose the disk to direct sunlight, extremes of temperature or humidity, magnetic fields, or dust.
- Place the disk in a protective cover when the disk is not inside the drive.
- Store disks in a clean, dry place.
- Clean the disk drive with a wet-dry cleaning kit regularly. Wet-dry cleaning kits are available from local computer stores.
  - Clean the disk drive every six months unless the working environment is particularly dusty or dirty. Clean the drive more often in dusty or dirty environments.
  - TraceMaster ECG Management System users:  
If you transfer ECGs to the TraceMaster System by disk, clean the TraceMaster drive every six months unless the working environment is particularly dusty or dirty. Clean the drive more often in dusty or dirty environments.
- Replace disks regularly. The recommended replacement interval is every three months. If the disks are used for more than 50 ECGs per day, replace the disks more frequently.
- For best results, use only Hewlett-Packard recommended disks. (HP part number M1700-89004)
- For more information, contact your Hewlett-Packard service representative.

### Cleaning the Electrodes, Leadwires, and Patient Data Cable

Clean the electrodes, leadwires, and patient data cable with a soft cloth moistened with soapy water. You also can use a disinfectant or cleaning agent such as Cetylde® , Cidex® , Lysol® , Wescodyne® , or Ves-phene® . Wring any excess moisture from the cloth before cleaning.

Caution



- Do not autoclave cable or use ultrasonic cleaners.
- The leadwires and patient module cable are not immersible.
- Do not use abrasive materials to clean metal surfaces—scratches on electrodes cause artifacts.

---

## Safety Tests

The safety tests listed below are performed at the time of manufacture to assure compliance with these standards: IEC 601-1, IEC 62D (CO)17, UL 544, and CSA 22.2 No. 125.

- Chassis-to-ground resistance
- Ground wire leakage current
- Enclosure leakage current
- Patient lead leakage current (source leakage) to ground
- Leakage current between patient leads
- Patient lead leakage current (sink current) with line voltage applied

Perform these tests as part of your preventive maintenance program, and after any corrective maintenance to assure compliance with the named standards.

To perform these tests, use a safety tester or analyzer designed specifically for this purpose. Follow the manufacturer's operating instructions.

**PageWriter XL  
Performance  
Verification  
Checklist**

Model number: \_\_\_\_\_  
Serial number: \_\_\_\_\_  
Test date: \_\_\_\_\_  
Test technician: \_\_\_\_\_

**Visual Inspection**

Disconnect the cardiograph from AC power and inspect for the following:

- Loose or missing hardware
- Frayed or damaged wiring
- Mechanical damage
- Evidence of liquid spill
- Printer drive gear wear
- Printer roller wear
- Wear or damage to power cord and associated strain relief
- Corroded or damaged electrodes
- Damaged leadwires or patient module cable
- Dirt on the thermal printhead

Connect the cardiograph to AC power and turn on the AC switch. Verify the following:

- The AC indicator is lit.
- One or more green battery indicators are lit when **On-Standby** is pressed to turn on the cardiograph.

**Extended Self-test**

Run Extended Self-test, select "All" menu choice, and verify that each test passes with no errors.

- Patient module and cable
- CPU assembly
- Printer
- Disk drive (writable disk must be in drive, M1700A and M1701A only)
- Preview display (M1700A only—de-select test if not installed)
- Keyboard display
- Modem (M1700A only—de-select test if not installed)

Print out the error log. Store the printout with the cardiograph's permanent maintenance record.





## Theory of Operation

---

This chapter contains an overview of the cardiograph operation, and circuit descriptions of the major subassemblies. Except as noted, the information in this chapter applies to the M1700A PageWriter XLi, the M1701A PageWriter XLs, and the M1702A PageWriter XLe.

---

### Operational Overview

This overview covers two areas of cardiograph operation: the path that ECG data follows from collection to display, and the cardiograph's power-on/power-off sequence.

#### ECG Data Path

ECG data is collected at the patient module. There, the data from as many as 13 patient electrodes is sampled after the multiplexors at a 4 kHz rate. The cardiograph software determines the number of electrodes sampled and the order in which they are sampled. Following the multiplexors is the analog-to-digital converter (ADC). The ADC, by the process of successive approximation, converts the multiplexed analog signals to digital words. The patient module controller performs a parallel-to-serial conversion, then sends the data to the cardiograph. In the cardiograph, the digital signal processor (DSP) receives the ECG data, processes it, and sends it to the system RAM where it is stored.

The data stored in memory is then available for analysis (M1700A only), printing, display, or storage to disk (M1700A and M1701A only).

## Power-on and Power-off Sequences

When the cardiograph is turned on or off, it follows a sequence of events in applying power to or removing power from its circuits. The gate array that controls dynamic RAM (DRAM) also controls this sequence because the DRAM gate array remains powered up even when the cardiograph is in Standby.

### Power-on

When the **On-Standby** key is pressed to power up the cardiograph, the DRAM gate array asserts the processor reset signal and sends the UNITON signal to the +5 V regulator to turn it on. When +5 V is in regulation, the power supply signals the DRAM gate array, which releases the processor reset.

When the reset is released, the processor begins execution at its reset vector, FFFFF0h. This location is in ROM, which contains initialization routines and tables. The flow chart in Figure 5-1 shows the sequence that the CPU executes to initialize the cardiograph and begin cardiograph operation. Cardiograph operation begins after the CPU has begun executing the software stored in RAM.

### Power-off

The power-off sequence is software controlled. The power-off sequence is initiated when the **On-Standby** key is pressed, battery timeout occurs, or the battery is too low to continue. At power-off, the software sees a keycode and begins housekeeping tasks such as completing disk I/O requests, turning off the printer, disabling the keyboard, turning off the keyboard display, and turning off the preview display if present. When the housekeeping is complete, the software instructs the DRAM and FGA gate arrays to stop the processor and shut down the power supply. The details of how the power supply shuts down are described later in this chapter in the power supply description.

Another method of shutting down the power supply is provided by the watchdog timer. The watchdog timer, part of the DRAM gate array, shuts down the power supply if the CPU is disrupted beyond recovery and fails to reset the timer before a specified time elapses. The timer is programmable and can be set by software for two, four, six, or eight seconds; the time depends on the operation currently being executed.

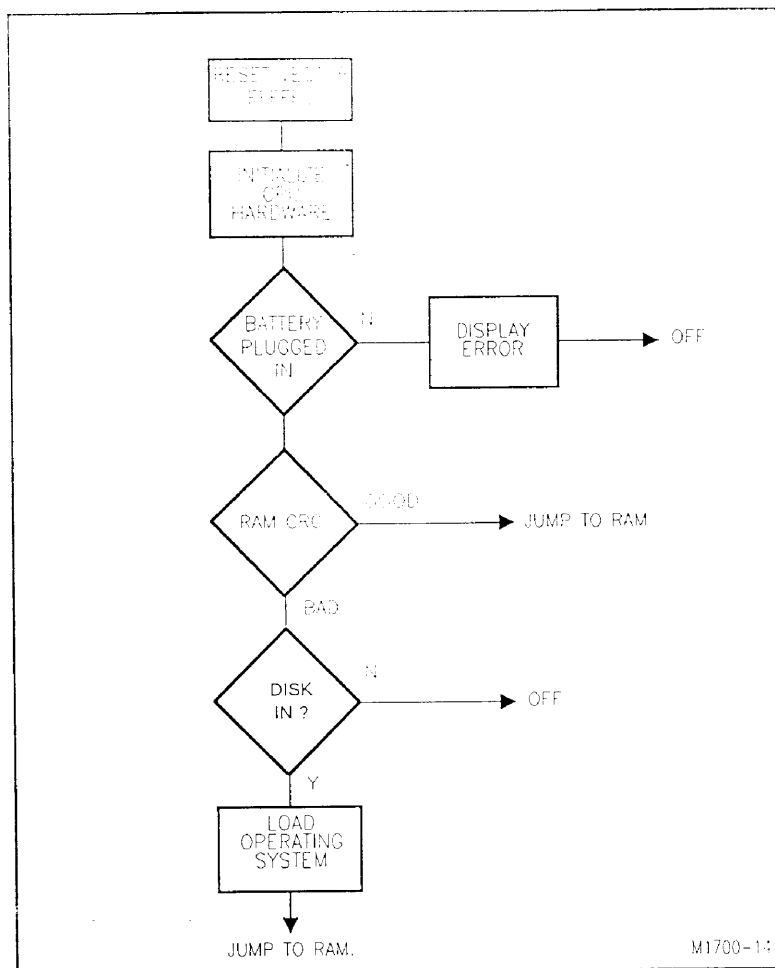

Figure 5-1. CPU Initialization Flow Chart.

Note



The M1702A cardiograph loads software from ROM, not disk.

---

## Circuit Descriptions

The major subassemblies for both cardiograph models are the patient module, the CPU assembly (which includes the power supply), the keyboard and LCD display, the printer, and the disk drive (M1700A and M1701A only). The M1700A also has an optional display that the operator can use to preview the ECG.

The CPU assembly is the same for both cardiographs except that the M1700A CPU assembly has extra RAM to accommodate the ECG interpretation and analysis software. The M1701A and M1702A CPU Assemblies are identical, except for the ROM. The subassemblies, including the CPU assembly and its major circuit groups, are shown in Figure 5-2.

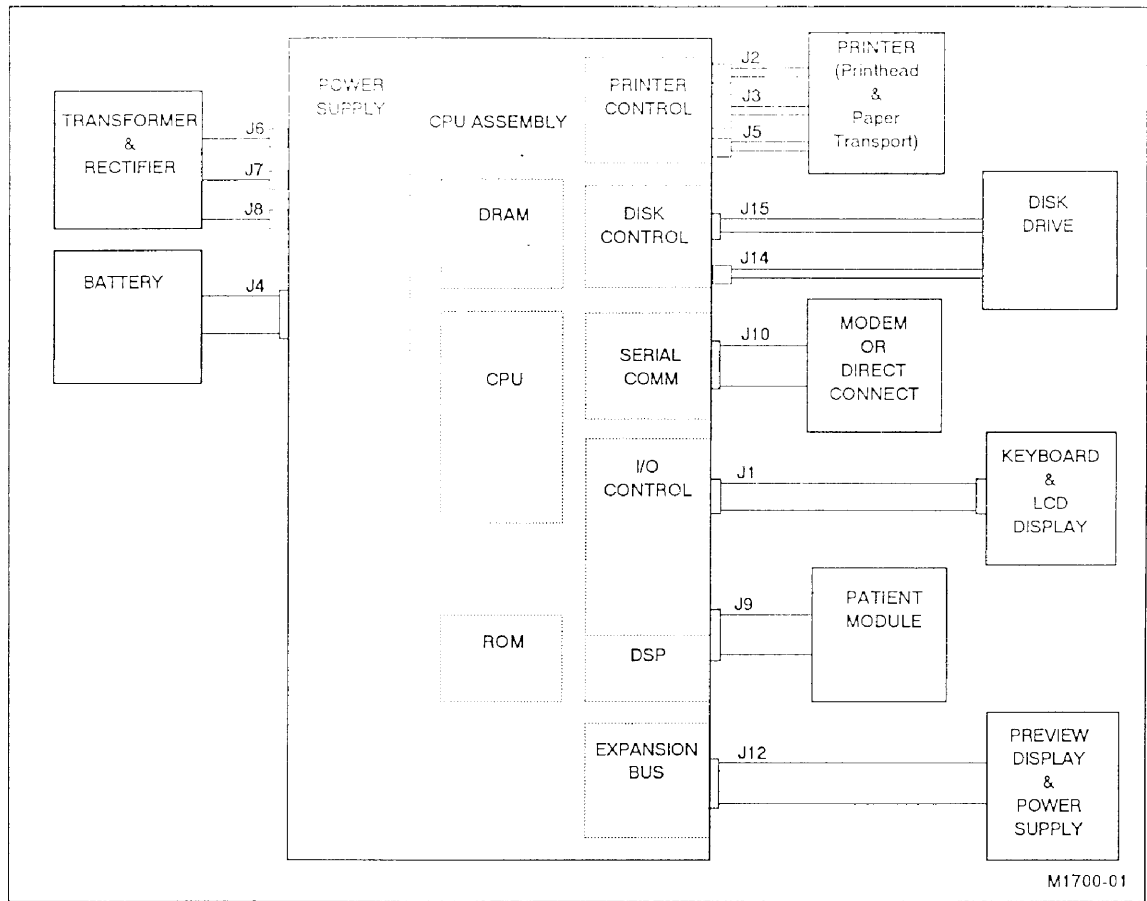

Figure 5-2. Simplified System Block Diagram.

Note



M1702A does not have a disk drive.

---

## The Standard Patient Module

The patient module collects data from up to 13 electrodes. The multiplexers sample the data and a calibration voltage at a 4 kHz rate, and a successive approximation analog-to-digital converter (ADC) digitizes the data. The patient module controller arranges the serial data from the ADC into 24-bit serial words that it sends to the cardiograph. The patient module electrically isolates the electrodes from the cardiograph with opto-isolators for the data and a transformer for the power.

The patient module receives leadwire status data from the cardiograph for presentation on the patient module's LCD display. A push button, , on the patient module allows the cardiograph operator to remotely start a recording. Figure 5-3 is a simplified block diagram of the patient module's circuitry.

---

### Note



PageWriter XLe, M1702A, does not have an LCD display or a push button.

---

The patient module connects to the cardiograph by a cable that plugs into the cardiograph at J9. The pin assignments for the patient module connector are described in Appendix A.

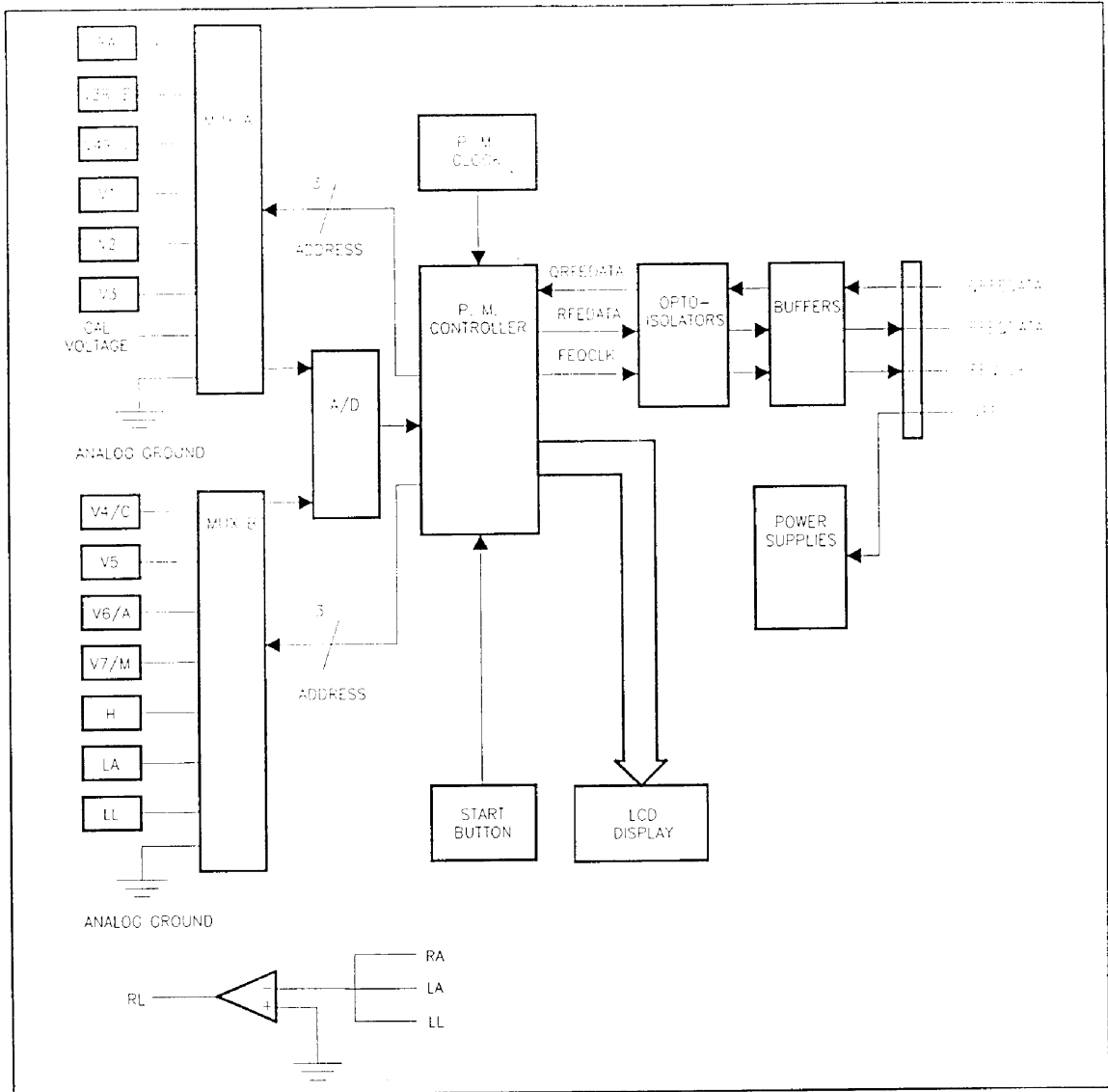

Figure 5-3. Patient Module Block Diagram.

---

## CPU Assembly

This discussion of the CPU assembly covers the following circuits:

- CPU
- System Memory
- ROM
- I/O Control
- Digital Signal Processor
- Flexible Disk Drive (M1700A and M1701A only)
- System Expansion Connector

The block diagram in Figure 5-4 shows these circuits and how they interconnect.

### CPU

The microprocessor used in the CPU is the Intel 80376<sup>®</sup>, a 32-bit processor with a 16-bit data bus and 24-bit address bus. The CPU address and data buses go to the DRAM block, the system expansion connector, and to latches and buffers, as shown in Figure 5-4. Address latches buffer the address signals in order to drive a larger number of devices and latch the addresses. Data buffers (transceivers) allow the CPU to communicate with a larger number of devices, and ensure that the CPU data bus is driven at the proper times. The programmable interrupt controller (PIC) accepts and prioritizes interrupt requests and generates the interrupt signal to the microprocessor.

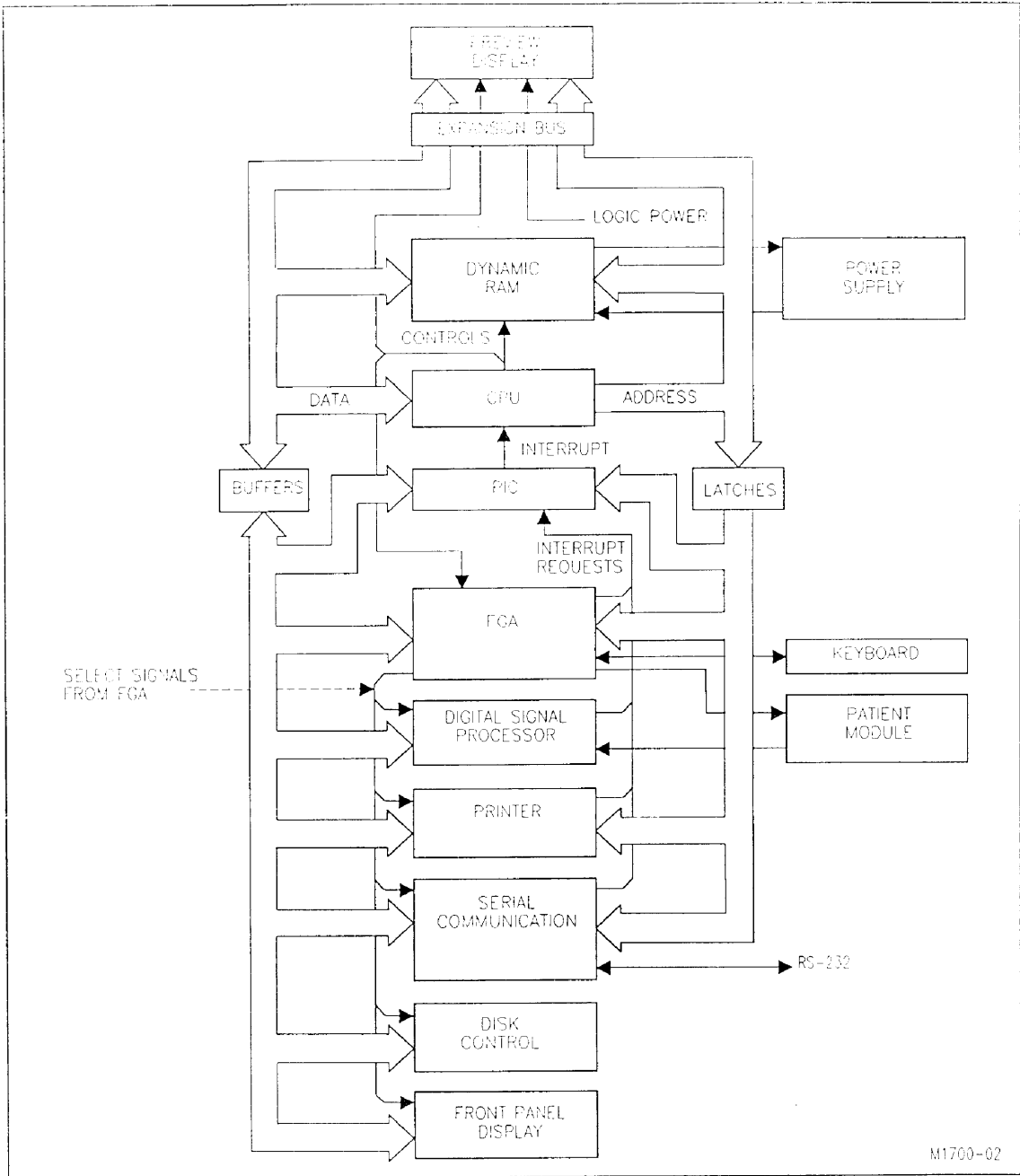

Figure 5-4. CPU Assembly Block Diagram.

## System Memory

The system memory circuitry consists of the DRAM array, the DRAM gate array, and two data transceivers, as shown in Figure 5-5.

The system memory provides storage for ECG data, printer image construction, signal processing needs, and system software.

The DRAM gate array controls RAM operations, including read, write, and refresh cycles. The refresh cycle continues when the cardiograph is in **Standby**. The DRAM gate array also provides the following:

- A watchdog timer—shuts off the system after a software selected delay if not reset by software.
- A real-time counter (RTC)—keeps track of elapsed time since the last RTC reset.
- Power supply support—manages the power-on and power-off event sequences.

The data transceivers buffer the data on the CPU data bus to provide adequate drive for the RAM array.

The system memory circuitry remains energized regardless of whether the cardiograph is **On** or in **Standby**. The only times that power is lost to system memory are when:

- The battery is not installed *and* the cardiograph is disconnected from AC power.
- The cardiograph enters the low battery shutdown condition.

When all power is lost to system memory, its stored data is lost including the configured software. This makes it necessary to reload the software from disk.

## ROM

The read-only memory consists of a 64K×16 EPROM (M1700A and M1701A), which stores the code that starts the system. The M1702A read-only memory consists of a 128k x 16 EPROM, which stores the cardiograph software.

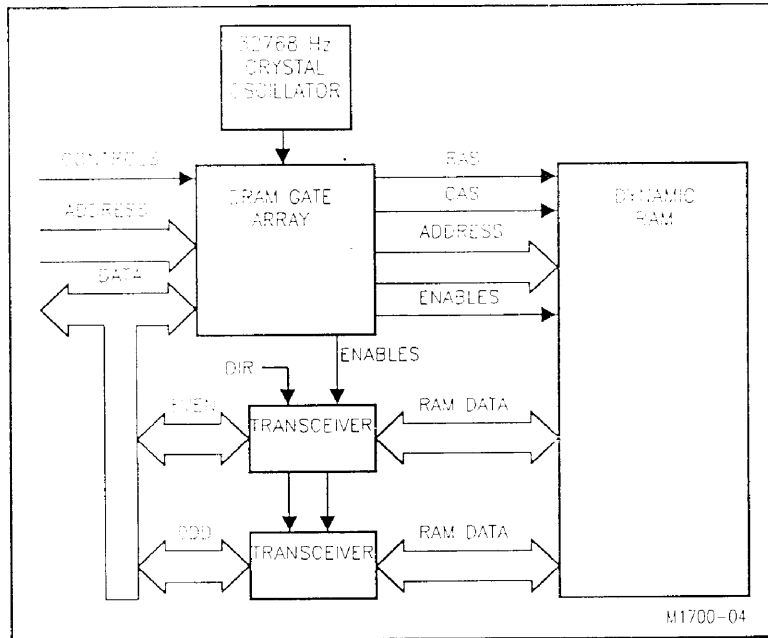

Figure 5-5. System Memory Block Diagram.

)

**I/O Control** The I/O control circuitry handles the system input and output. The block diagram in Figure 5-6 shows the major elements.

**The FGA**

The primary element in the I/O control is the “Foundation” gate array (FGA). It provides the following functions:

- Keyboard interface
- Data bus arbitration
- Transmit portion of the patient module interface
- Enable and Select generation
- System clock generation
- Baud rate generation

The FGA, in its role as keyboard interface, sends and receives data directly to and from the keyboard through a 1200 baud serial interface.

As data bus arbitrator, the FGA enables and controls the direction of the data transceivers that buffer system data. The FGA also generates the read and write enable signals and the chip select signals for all I/O devices.

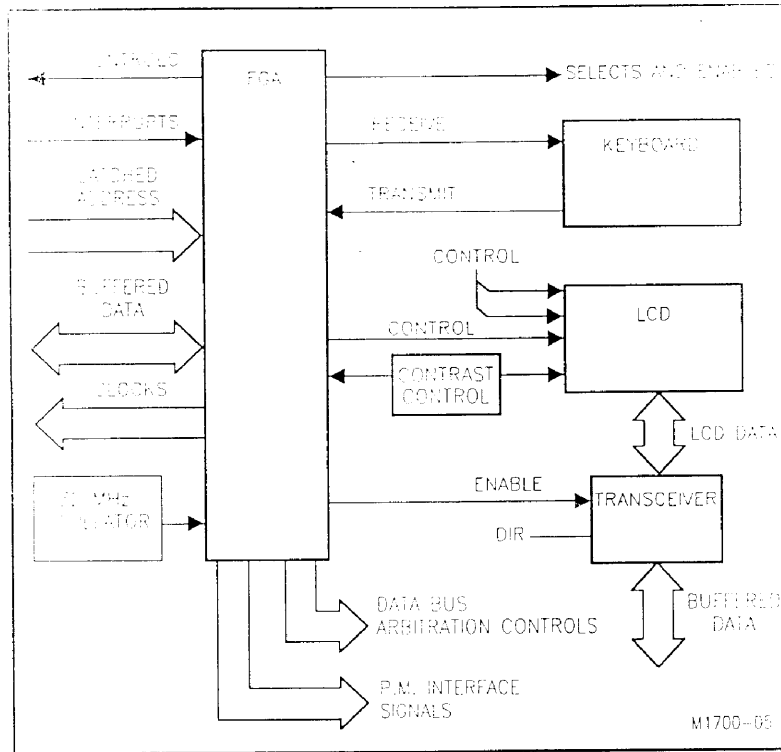

Figure 5-6. I/O Control Block Diagram.

### Serial Communications

The other important element in the I/O control circuitry is the serial communications block (shown in Figure 5-7), which provides asynchronous serial communication for direct connect or modem. The universal asynchronous receiver/transmitter (UART) circuit provides buffering, parity, handshake logic, interrupt capabilities, and parallel-to-serial conversions for sending and receiving RS-232 data. The driver/receiver circuit converts serial signals between RS-232 voltage levels and TTL levels.

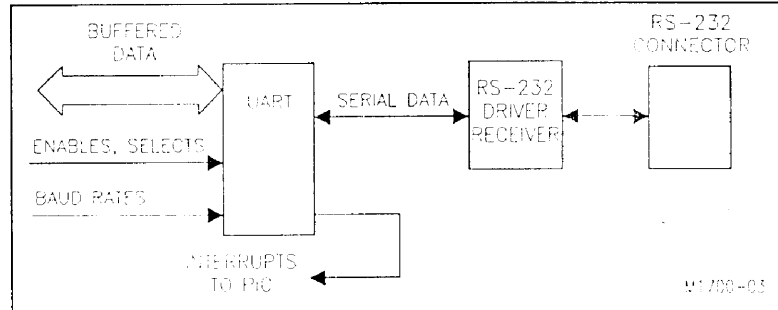

Figure 5-7. Serial Communications Circuitry.

### Digital Signal Processor

The digital signal processor (DSP) assembly consists of a Motorola 56001<sup>®</sup> digital signal processor and three static RAMs that provide 32K words (24 bits-per-word) of memory. Refer to Figure 5-8.

The DSP provides a high-speed, synchronous interface for 24-bit serial data from the patient module, and digital filters for ECG data.

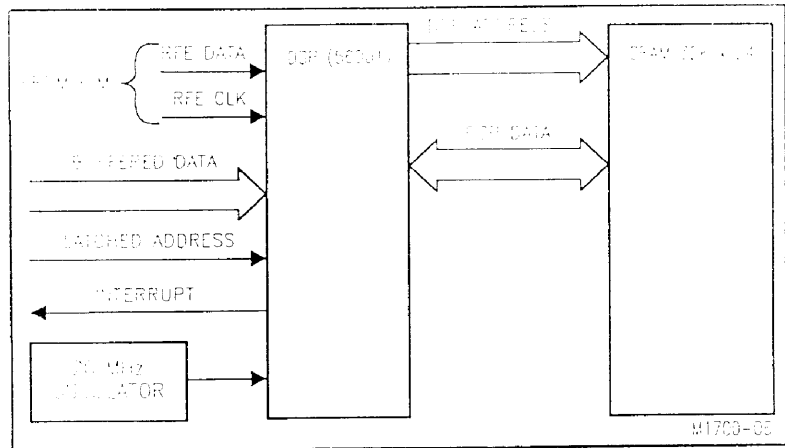

Figure 5-8. Digital Signal Processor Block Diagram.

**System Expansion Connector**

The system expansion connector, J12, provides the CPU signals and power sources required by the preview display assembly. The pin assignments for this connector are listed in Appendix A.

**Disk Drive (M1700A and M1701A only)**

The disk controller on the CPU assembly (see Figure 5-9) provides the interface to the system data bus for the 3.5-inch disk drive. The disk drive connects to the CPU assembly through two connectors, J14 (disk power) and J15 (data and control signals). Pin assignments for these connectors are described in Appendix A.

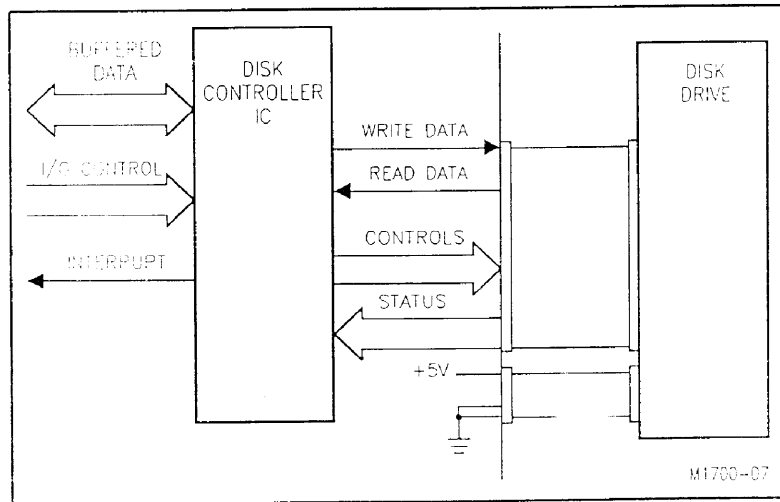

Figure 5-9. The Disk Drive and its Control Circuit.

---

## Power Supply

The power supply's basic tasks are to charge the battery when the cardiograph is connected to AC power, provide +5 volts to the system logic, provide power to the printer, and provide operating voltage to the patient module. These are the circuits that make up the power supply:

- Battery Charger and Battery Sensor
- 5 Volt Regulator
- +5 Overvoltage/Undervoltage Sensor
- Printer Switch
- Battery Switch
- ACON Detector
- +5 Backup Supply and Low Battery Disconnect
- +5-to-Backup Switchover
- Patient Module Voltage Regulator

### Note



Although the power supply circuits are discussed separately from the CPU assembly, they are all physically located on the CPU assembly except for the battery, the transformer, and the diode assembly cable, which includes the rectifier and filter capacitors.

Figure 5-10 shows how these circuits connect to each other and to other parts of the system.

### VMAIN and VIN

VMAIN connects to the CPU assembly at J6 and J7. It is the unregulated, rectified AC that comes from the main transformer and bridge rectifier assembly. After passing through a fuse, VMAIN becomes VIN, which supplies power to the +5 volt regulator, the patient module regulator, and the preview display assembly.

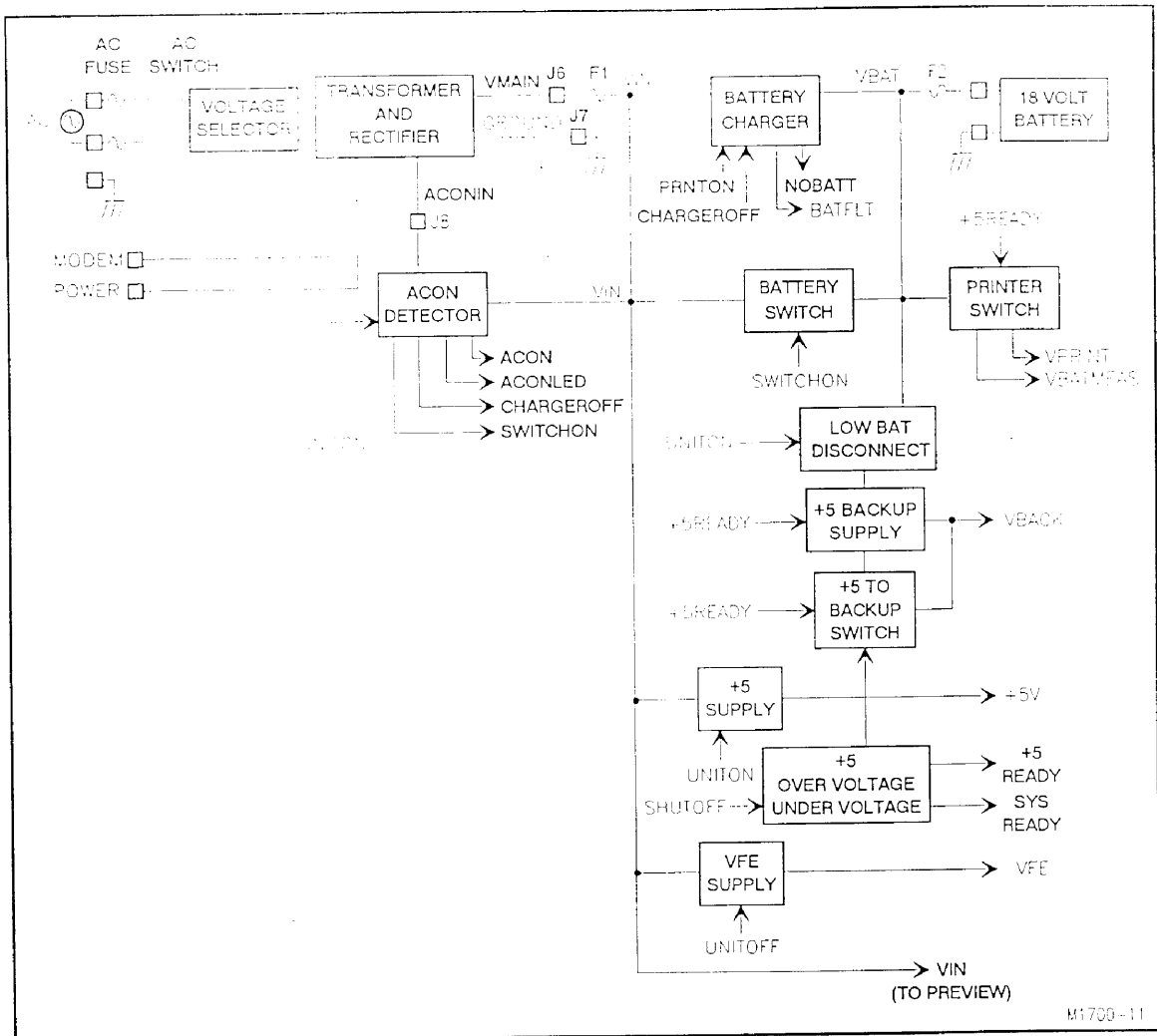

Figure 5-10. Power Supply Block Diagram.

## Battery Charger and Battery Sensor

The battery charger converts VIN (15 to 31 volts) to VBAT (20 to 22 volts). VBAT connects to the + terminal of the battery through a fuse, which is located on the CPU assembly. The battery connects to the CPU assembly at J4. Pin assignments for the battery connector are listed in Appendix A, "Pin Assignments." The converter is of the "buck-boost" type. It is actually a "buck" rectifier connected to a "boost" (step-up) regulator so that the output voltage can be higher or lower than the input voltage.

Two circuits provide current limiting. One limits charging current to the battery to 1.7 amps average. The other current limit circuit limits the charger output current to a peak 5 amps. This has two purposes:

- To limit peak current during power-on and power-off.
- To limit peak current from the battery charger during printer power-on. When the printer turns on, it can draw peaks of current as high as 20 amps. The battery and battery charger provide this current. This current limit circuit helps prevent overstressing the switching FETs.

There are two output voltage modes, cycle and float. The charger enters cycle mode when the charging current exceeds 400 to 700 mA. In cycle mode, the output voltage is fixed at approximately 21 to 22 volts. The charger enters float mode when charging current is less than 400 to 700 mA. In float mode, the output voltage varies inversely with battery temperature. The charger determines temperature by measuring a voltage across a thermistor in the battery.

### Battery Operation and Condition

When operating on battery power, the cardiograph software monitors the battery and displays the amount of charge remaining on the front panel battery indicator. When the low battery indicator on the front panel illuminates, the battery has discharged to the low battery warning point. The cardiograph can continue to operate in this condition until it reaches the low battery shutdown point.

The low battery shutdown point occurs when the battery is approximately 70% discharged. The low battery indicator begins flashing and the message "Low battery, plug cardiograph into AC." is displayed. After one minute, the cardiograph will go to **Standby** unless it is connected to AC before the minute expires. If the battery is not allowed to recharge, it will continue to discharge until it reaches the low battery disconnect point.

Low battery disconnect occurs when the battery is approximately 80% to 90% discharged. When this occurs, the battery is completely disconnected from the system, and memory and clocks are lost. The disconnect circuit is described later in this section.

### 5 Volt Regulator

The 5 volt regulator provides logic power to the cardiograph. This regulator converts VIN to +5 volts  $\pm 5\%$  with a "buck" (step-down) converter. The UNITON signal from the DRAM gate array turns the regulator on and off, and soft-start circuitry prevents voltage overshoot at start-up. Maximum rated output current is 3 amps.

### +5 Overvoltage/ Undervoltage Sensor

This circuit monitors the +5 volt supply to sense an overvoltage or undervoltage condition.

When the **On-Standby** key is pressed to turn the cardiograph **On**, +5READY goes high as soon as +5 volts is within regulation. +5READY enables the printer switch and preview display, and disables the backup supply. After about 100 ms SYSRDY goes high. This delay allows the VBACK supply to equalize voltage with the +5 volt supply.

When the **On-Standby** key is pressed to place the cardiograph in **Standby**, the system software enters the power-off sequence described earlier in this chapter. The DRAM gate array asserts the SHUTOFF signal, which causes +5READY and SYSRDY to go low. When +5READY goes low, it disconnects the printer switch and enables the backup supply, which provides power to the DRAM. After 30 to 60 ms, the UNITON signal goes low and turns off the +5 regulator.

As long as the supply remains within tolerance, the +5READY and SYSRDY signals remain high. When the +5 volt supply exceeds the tolerance in either direction, +5READY goes low.

**Printer Switch** This block consists of two separate circuits: the printer switch and the voltage reference.

The printer switch provides battery power, VBAT, to the printhead and printer motor. The signal name for the switched power is VPRINT. The switch, which consists of three power FETs, closes when +5READY goes high. A voltage divider scales down VPRINT to produce VBATMEAS. The print circuitry uses VBATMEAS to update the front panel battery level indicator, to initiate low battery shutdown if necessary, and to provide printhead voltage to the printer gate array.

**Battery Switch** This circuit connects the battery (VBAT) to VIN when the cardiograph is not connected to AC power. This provides power to the +5 and patient module voltage regulators and to the preview power supply. The switch, which consists of three FETs, closes when SWITCHON (from the ACON circuit) is high.

A diode in the circuit isolates VIN from the battery during printer current surges.

**ACON Detector** This circuit generates the SWITCHON signal that controls the battery switch, and the CHARGEROFF signal that controls the battery charger. When the cardiograph is running on battery power, the CHARGEROFF and SWITCHON signals are high, which disables the battery charger and enables the battery switch, respectively. When running on AC power, CHARGEROFF and SWITCHON are low, enabling the battery charger and disabling the battery switch. The ACON circuit samples AC voltage directly off of the main transformer secondary, rectifies it, and compares it to a reference voltage from the backup supply. ACON is high when AC power is on.

ACONLED drives the AC indicator LED on the front panel.

**+5 Backup Supply and  
Low Battery Disconnect**

The +5 backup supply (VBACK) provides power for DRAM and associated logic when the cardiograph is in Standby. When the cardiograph is **On** and the +5 supply is in operation, the backup supply is disabled and the +5 supply is connected to VBACK.

The low battery disconnect circuit will disconnect the battery from the backup supply when the battery is approximately 80% discharged. This will occur only when the cardiograph is in Standby *and* is disconnected from AC power. The disconnect circuit is disabled when UNITON is high. This avoids tripping the disconnect circuit when battery voltage dips momentarily due to load.

**Note**



When this circuit disconnects the battery, power to DRAM is lost, resulting in the loss of system software and configuration data. The software and configuration data must be reloaded from disk before the cardiograph can be used.

**+5 to Backup  
Switchover**

At power-on, this circuit connects the +5 V supply to VBACK as soon as +5 V comes into regulation (+5READY goes high). At power-off, this circuit disconnects +5 V from VBACK.

**Patient Module Voltage  
Regulator**

This circuit provides power (VFE) to the patient module. The regulator is enabled when UNITOFF (from the DRAM gate array) goes low, and is disabled when UNITOFF goes high. Output voltage is between 10.0 and 11.5 volts at 0 to 220 mA load. In the disabled state, output voltage is about 1.3 volts while running off of AC, and 0 volts while running off of the battery.

---

## The Keyboard and Keyboard Display

The keyboard and the keyboard display constitute the front panel controls and indicators. They share a connector that plugs into the CPU assembly at J1 (refer back to Figure 5-2). Pin assignments for J1 are listed in Appendix A.

The keyboard consists of the control switches, the alphanumeric keyboard, and the LED indicators. The keyboard communicates with the CPU assembly over serial transmit and receive lines. The system reads keycode information on the transmit line, and writes LED indicator information on the receive line. While the cardiograph is in **Standby**, the **On-Standby** key is connected to the system by a separate signal line; when the cardiograph is **On**, the **On-Standby** key is also encoded like the other keys. The AC indicator is driven by the system through a separate signal line.

The keyboard display is a 40-character, 2-line, alphanumeric LCD. It receives 8-bit data from the system, and control signals from the FGA.

---

## Printer

The cardiograph's printer consists of the control and drive circuitry on the main circuit board, the thermal printhead, and the paper transport mechanism. The block diagram in Figure 5-11 shows how these parts connect to each other and to the rest of the cardiograph.

### Printer Gate Array

The printer gate array is the principal component of the printer control circuitry. It buffers print data coming from the system and status data going to the system, controls printer timing, controls the printer RAM, regulates motor speed, monitors printhead temperature and resistance, monitors the battery condition, and provides the interface between the printer and the system CPU.

### Printer RAM

The printer RAM consists of 32 kilobytes of static RAM used to store printer data and the printer look-up table data. The look-up table data is used to compensate the motor drive signals and the printer enable pulses for variations in the operating environment. The look-up table data also includes the motor settings and the motor ramp-up profile.

### Motor Driver

The phase signals from the printer gate array enable the motor driver circuit, which switches current through the stepper motor in the paper transport.

ADC (Analog-to-Digital Converter)

This is an 8-bit parallel A/D converter used to measure printhead temperature, battery voltage, and motor supply voltage.

Thermal Printhead

The thermal printhead is a line of 1728 printing elements. Each printing element is a resistive heater. Heat from these elements blackens the thermoreactive paper, creating an image. A 1728-bit shift register (on the printhead) contains the dot data for the print line. Data is serially loaded into the shift register, then latched so that data for the next line may be shifted into the head while the present line prints. A strobe signal enables printing. The pulse width of the strobe is adjusted to compensate for different recording speeds and variations in supply voltage, average heater resistance, and temperature, which is sensed by a thermistor on the printhead heat sink.

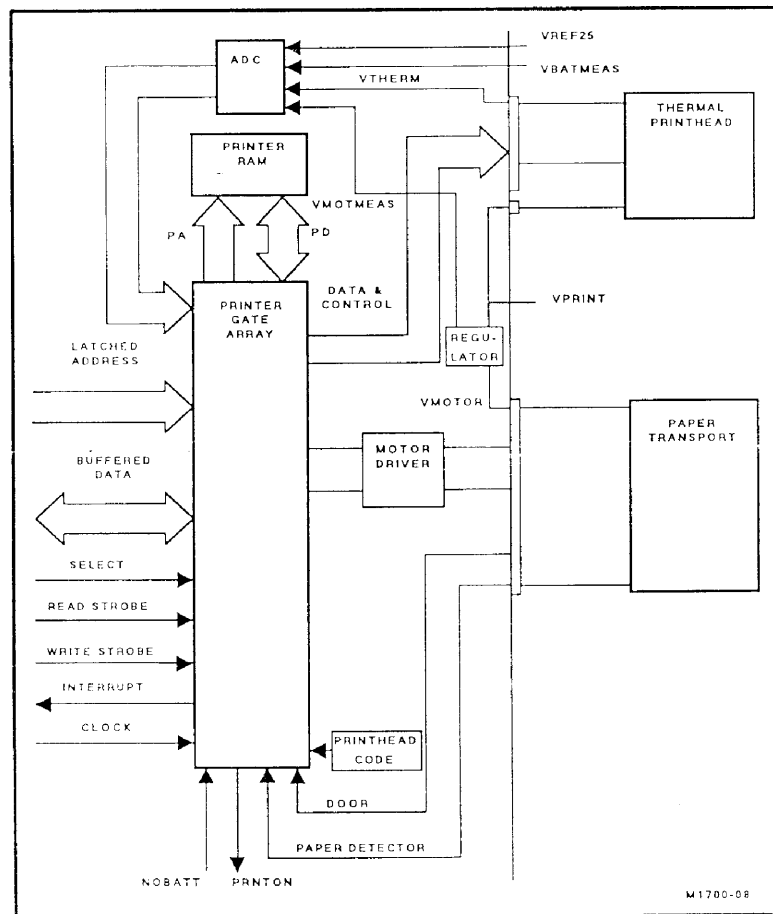

Figure 5-11. Printer Block Diagram.

## The Preview Display

Note



The preview display is available only on the M1700A.

The preview display consists of three subassemblies:

- The preview logic board
- The preview power supply board
- The preview LCD

The preview logic board connects to the system expansion connector on the CPU assembly. The three subassemblies then connect to each other as shown in Figure 5-12. Pin assignments for the preview display connectors are listed in Appendix A.

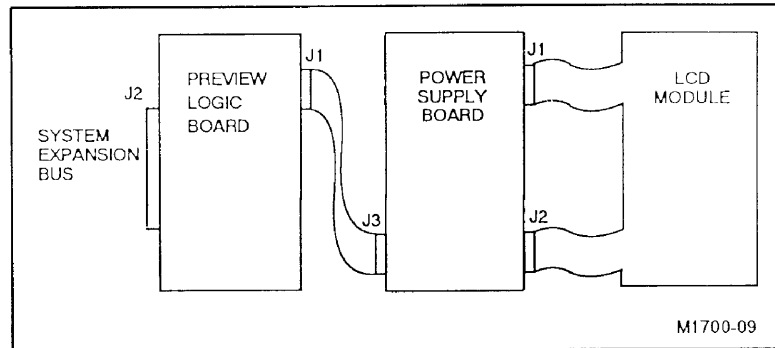

Figure 5-12. Preview Display Subassembly Connections.

## Preview Logic Board

The preview logic assembly is diagrammed in Figure 5-13. The buffers reduce loading on the CPU address, data, and system control lines and ensure proper logic levels and transitions for the preview logic circuitry.

The address decoder determines whether the system has access to the LCD static RAM (SRAM) or the LCD controller. Upon recognition of the proper addresses, the decoder generates control signals that provide the following:

- read/write access to the LCD bit map stored in static RAM (SRAM) for display data reads and writes.
- write-only access to the LCD controller's internal control registers for I/O register writes (usually done at system initialization).

The SRAM address bus can be driven by the CPU or by the LCD controller. The address multiplexers, under the control of the LCD controller, select between these two address sources. In the event of contention, the LCD controller forces the CPU to wait for access to the RAM.

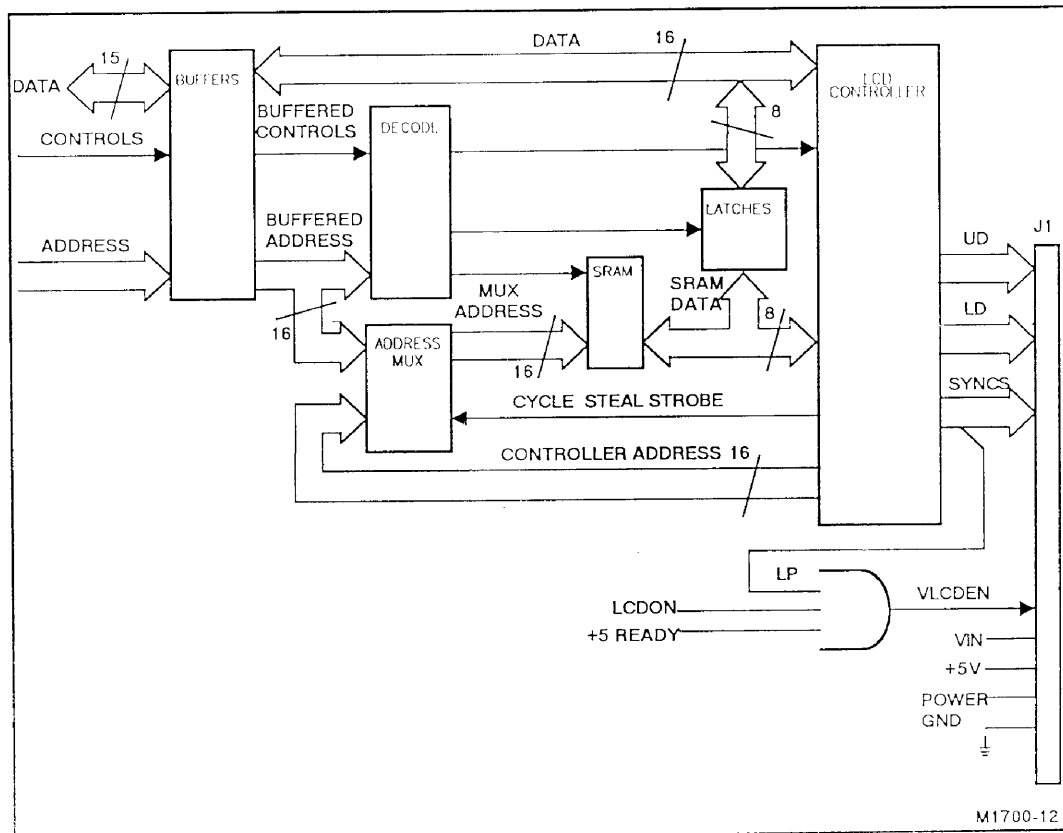

Figure 5-13. Preview Logic Board Block Diagram.

The SRAM is a CMOS 32Kx8 static RAM that contains a complete graphics bit map of the LCD. Display data is written to or read from SRAM.

The LCD controller reads the display data from SRAM and outputs it on the upper and lower screen data lines (UD and LD). The controller also generates synchronization signals that send the data to the LCD.

The LCD enable circuitry generates the VLCDEN signal that allows the system to turn the LCD (and backlight) on and off. Functionally, this circuit is an AND gate that generates VLCDEN when +5 volts is stable (+5READY) *and* the system has turned on the LCD (LCDON). The latch pulse signal (LP) must also be present before the LCD can be turned on, thus preventing damage to the LCD.

The upper screen and lower screen data lines (UD and LD), sync signals (FP, LP, and SCP), VLCDEN, VIN, +5 volts (VCC), and GROUND leave the preview logic board and connect to the preview display power supply board.

### Preview Display Power Supply Board

The preview display power supply board, shown in Figure 5-14, provides three sources of power to the LCD module:

- VCC (+5 V DC)
- VLCD (-6 to -23.5 V DC)
- VCFL (about 400 V RMS @ 30 kHz)

#### Note



---

The upper and lower screen data signals (UD and LD), and the sync signals (LP, FP, and SCP) pass unaffected through this board to the LCD module.

---

VCC, which is obtained from the main system +5V power supply, provides basic power to the LCD and its associated driver ICs. VLCD controls the LCD contrast (the optical characteristic of the LCD), and VCFL controls the LCD brightness (the intensity of the cold cathode fluorescent backlighting).

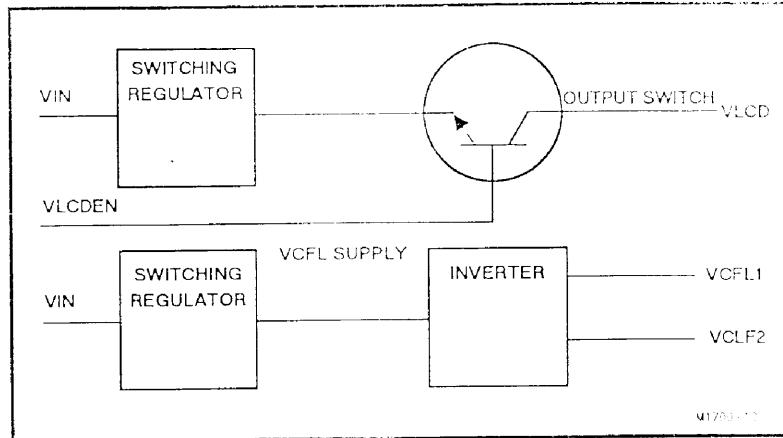

Figure 5-14. Preview Display Power Supply Block Diagram.

#### VLCD Supply

The VLCD (contrast) supply is a buck-boost type DC-DC converter that derives VLCD from VIN. The contrast potentiometer controls VLCD voltage level.

The series transistor in the output is a switch that is controlled by the VLCDEN signal. It prevents application of VLCD to the LCD module before VCC is stable at power-on, and switches off VLCD prior to VCC at power-off. This prevents damage to the LCD driver ICs.

The VLCDEN signal may be controlled by the CPU software, providing a software-controlled means of blanking the LCD.

#### VCFL Supply

The VCFL (brightness) supply consists of two stages. The first stage is a switching regulator that converts VIN into a voltage that is varied by the brightness potentiometer. The second stage is a high voltage inverter module that generates the high voltage AC signal necessary to operate the fluorescent lamps used for display backlighting.

#### Preview Screen

The preview screen is a 640×400 dot LCD with cold cathode fluorescent backlighting. The LCD driver circuitry receives control and data signals that originate from the preview logic board. The latch pulse (LP), frame pulse (FP), and shift clock pulse (SCP) control signals synchronize the LCD. The UD and LD lines provide display data to the LCD.



## Troubleshooting

---

### Introduction

This chapter provides information for localizing cardiograph problems to the subassembly level. This information is designed for use with the cardiograph's Extended Self-test to help you efficiently repair the cardiograph with a minimum of equipment.

---

### Maintenance Philosophy

The maintenance philosophy for the cardiograph is subassembly replacement. Replaceable subassemblies are identified in Chapter 8, "Parts List".

#### Caution



Individual component replacement should not be attempted outside of an authorized Hewlett-Packard repair facility. Component level repair is extremely difficult due to the extensive use of surface mount technology and the high parts density on the circuit boards. Unauthorized component replacement can impair cardiograph performance and jeopardize credit towards a replacement assembly.

---

---

### Test Equipment

The following test equipment is required to troubleshoot the cardiograph as described in this chapter:

- A digital voltmeter such as the Hewlett-Packard E2373A hand-held multimeter.
- A 12-lead ECG simulator.
- A blank 1.44-Mb disk (not needed with M1702A).

---

## The Error Log

All events that produce displayed errors place those errors into the error log (this does not include power-on errors, or operator error messages such as an out of paper message). The error log can be printed by entering Extended Self-test and selecting the ErrorLog key as explained in Chapter 4. The printed error log includes four fields for each logged error (see Figure 6-1):

Error	The error code. Useful in diagnosing what is happening in the cardiograph. Frequent errors of the same type are indications of a problem, especially if they are logged close together in time.
Date	The date the error occurred (as set on the cardiograph).
Time	The time the error occurred (as set on the cardiograph).
Status	This field is reserved for factory use. It may help factory personnel assist on very difficult problems. The error log lists the 100 most recent events.

### Clearing the Log

The stored error log is cleared each time the software is reloaded, whether from the System disk that comes with the cardiograph, or from a user's configuration disk.

If you are troubleshooting a problem, you should print the error log before you reload the software. This can assist in determining the cause of the failure. If the failure disappears after reloading the software, the loaded software may have been corrupt. If the failure continues after reloading the software and produces the same error code, a hardware problem is likely.

ERROR LOG				LOC 00000 - 0000				04/01/1990 02:42:09 PM	
Error	Date	Time	Status	Error	Date	Time	Status		
05007	01/01/1989	00:01:16	0000000	05007	04/01/1990	14:39:24	0000000		
03510	03/30/1990	15:00:20	0000005	05007	04/01/1990	14:39:33	0000000		
04007	03/30/1990	15:04:00	0006002	05007	04/01/1990	14:40:42	0000000		
04007	03/30/1990	15:04:46	0006002	05007	04/01/1990	14:40:57	0000000		
04007	03/31/1990	08:18:08	0006002	05007	04/01/1990	14:39:24	0000000		
04007	03/31/1990	08:20:15	0006002						
05007	03/31/1990	08:20:52	0000000						
03510	03/31/1990	08:22:40	0000005						
03510	03/31/1990	08:23:55	0000005						
03510	03/31/1990	08:24:01	0000005						
03510	03/31/1990	08:25:16	0000005						
04003	03/31/1990	08:26:43	0000005						
04003	03/31/1990	08:26:43	0000011						
05007	03/31/1990	08:27:50	0000000						
05007	03/31/1990	08:31:51	0000000						
05007	03/31/1990	09:00:31	0000000						
03510	03/31/1990	09:04:24	0000005						
03510	03/31/1990	09:04:44	0000005						
03510	03/31/1990	09:06:07	0000005						
05007	03/31/1990	09:07:39	0000000						
05007	03/31/1990	09:07:51	0000000						
03510	03/31/1990	09:08:03	0000005						
03510	03/31/1990	09:08:35	0000005						
03510	03/31/1990	09:09:23	0000005						
03510	03/31/1990	09:12:37	0000005						
03510	03/31/1990	09:13:29	0000005						
03510	03/31/1990	09:14:57	0000005						
05007	04/01/1990	11:24:30	0000000						
05007	04/01/1990	11:24:35	0000000						
03510	04/01/1990	11:25:49	0000005						
03510	04/01/1990	11:28:07	0000005						
03510	04/01/1990	11:28:13	0000005						
05007	04/01/1990	11:29:47	0000000						
05007	04/01/1990	11:30:38	0000000						
05007	04/01/1990	12:42:01	0000000						
05007	04/01/1990	12:43:18	0000000						
03510	04/01/1990	12:45:30	0000005						
05007	04/01/1990	14:37:16	0000000						
05007	04/01/1990	14:37:40	0000000						
05007	04/01/1990	14:38:34	0000000						

HP-001

Figure 6-1. Sample Error Log Printout.

**Errors** The following list describes the errors that can appear in the error log.

Error	Description
1499	This error occurs when the software detects an error that cannot be corrected. Set the cardiograph to Standby then back to On and check if the error repeats.  If the error repeats, use Extended Self-test to help locate the failure. Extended Self-test is explained in Chapter 4.  If Extended Self-test does not locate the problem, print out the error log, then reload the software from the System Disk that came with the cardiograph.  If the failure persists, replace the CPU assembly.

1540	This error is logged when the message <code>Data transmission abnormal termination.</code> appears. The error is received from the remote system, and the Status field on the printout shows the error passed by that system.
1541	This error is logged when the message <code>Data transmission abnormal termination.</code> appears and indicates a transmission problem at the local cardiograph. Try each of these possible remedies: <ol style="list-style-type: none"> <li>1. Check cabling</li> <li>2. Retry the operation</li> <li>3. Use a different phone line</li> <li>4. Check with the system operator to find out if abnormalities exist at the other end</li> </ol>
9000-9499	Errors in this range indicate a communication problem between the cardiograph and the patient module. The problem can be caused by hardware or software, and can occur in the cabling, the CPU assembly, or the patient module. To locate and correct the problem, use these actions: <ol style="list-style-type: none"> <li>1. Check all cables</li> <li>2. Cycle the power</li> <li>3. Run Extended Self-test</li> <li>4. Reload the software</li> <li>5. Refer to the troubleshooting table for the patient module and cable</li> </ol>

---

## Using Extended Self-test in Troubleshooting

The cardiograph's Extended Self-test is a simple-to-use, looping test that gives you pass/fail status for each of these major subassemblies:

- Patient module and cable
- CPU assembly
- Printer
- Disk drive (M1700A and M1701A only)
- Preview display (M1700A only)
- Keyboard display
- Modem and cable (M1700A only)
- Fax modem (M1756A only)

Instructions for entering and using Extended Self-test are found in Chapter 4, "Performance Verification and Maintenance."

The messages in the following list are Extended Self-test's failure messages. If a subassembly test fails, the failure message for that subassembly appears in the keyboard display. The message remains there until you set the cardiograph to **Standby** (or it shuts itself off to preserve the battery). Because the keyboard display is tested entirely with a test pattern, there is no failure message for the keyboard display test. Test pattern errors must be visually detected while the test patterns are displayed. This is also true for the test patterns displayed on the preview screen, the patient module display, and the printer:

- Patient module test failed.
- Patient module cable test failed.
- CPU assembly test failed.
- Printer test failed.
- Disk drive test failed.
- Preview test failed.
- Modem test failed.

---

## Troubleshooting Tables

The troubleshooting tables in this section help you to localize a fault and correct it. The troubleshooting flowchart in Figure 6-2 guides you to the troubleshooting table that covers a particular functional area of the cardiograph.

Table 6-1 lists errors that can occur only during the power-on routine and will appear only as numbers on the display. The table defines and explains each error, and suggests one or more corrective actions for each. All the other tables list failure symptoms, possible causes, and suggested remedies.

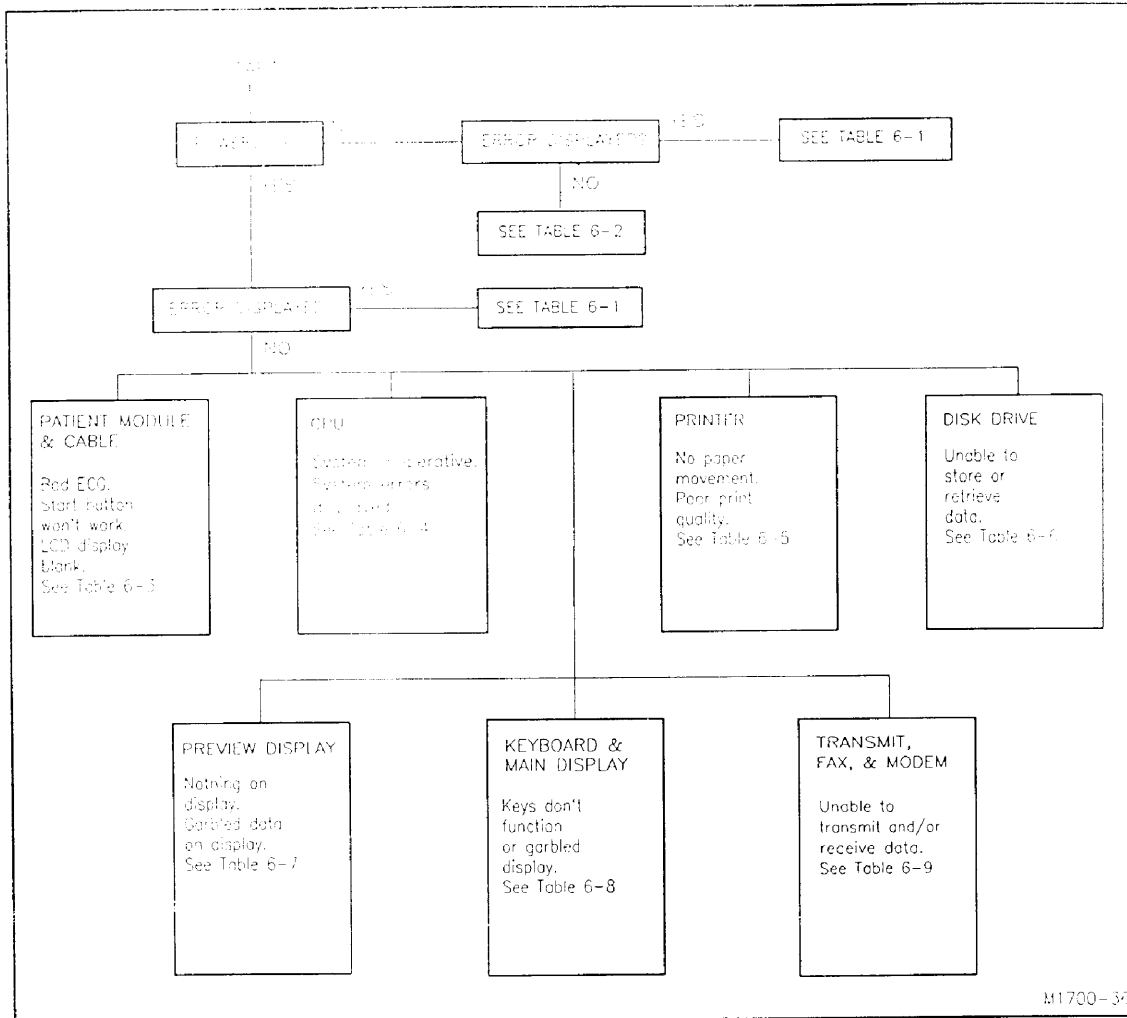

Figure 6-2. Troubleshooting Flowchart.

**Caution**



Before removing or inserting any board or connector, make sure AC power is off, the battery is removed, and the rectifier assembly capacitors are discharged.

Note



---

In Table 6-1, the corrective action “Cycle power” means to press the **On-Standby** key repeatedly to turn the cardiograph to Standby and back to On.

---

Tip



---

If the cardiograph will not turn on or operate and displays an error code, the preview logic board may be defective and causing these symptoms. Try disconnecting the preview logic board to eliminate it as the source of the power-on problems.

---

Table 6-1. Power-on Errors

Error #	Definition	Corrective Action
6500	Defective ROMs or other related hardware problem on CPU assembly.	Replace CPU assembly.
6501	Failed to initialize disk controller. Disk drive connecting cable bad, disk drive bad, or CPU assembly bad.	1. Replace cable. 2. Replace disk drive. 3. Replace CPU assembly.
6502	Failed to complete loading of software.	Reload software.
6503	No RAM code found in machine. A.01.00 software defect.	1. Reload software. 2. Load software version A.01.01 or later. 3. Replace CPU assembly.
6504	RAM cyclic redundancy check (CRC) failed--RAM code corrupt after loading code.	Reload software.
6505, 6506	Insufficient memory. M1700A software loaded into an M1701A.	1. Load proper software. 2. Replace CPU assembly.
6600, 6601	Catastrophic software failure.	Reload software.
6602	Failures in power-on routine.	1. Cycle power. 2. Reload software. 3. Replace CPU assembly.
6605, 6609, 6610	Missing message table. Disk could be bad.	Reload software.
6606, 6607	Failures in power-on routine.	1. Cycle power. 2. Reload software. 3. Replace CPU assembly.
6612	Wrong message table version.	Reload software.
6613, 6614, 6615, 6616	Software failure.	Reload software.
<del>6990</del> , 6991	Software corrupt.	Reload software.

**Note**



To reload the software on the M1702A XLe, remove the battery, then reinstall the battery and reconfigure the unit.

Table 6-2. Power Supply and Battery

Symptom	Cause	Corrective Action
Message: No battery. Load battery. Cardiograph won't turn on.	Battery not installed.	Install the battery, then try turning on the cardiograph.
One or more power supply voltages missing (see "Testing the Power Supply" at the end of this chapter).	Defective regulator circuit(s).	Replace CPU assembly.
AC indicator not lit.	Power cord unplugged. AC switch is off. AC fuse is blown. ACON connector not plugged in. Bad user interface cable. Bad keyboard circuit board. VMAIN connector (J6) not plugged in on CPU assembly. VBACK or VBAT regulator defective. VMAIN or VIN not present.	Plug in power cord. Turn on AC switch. Replace AC fuse. Plug in ACON connector. Replace cable. Replace user interface assembly. Plug in VMAIN connector.  Replace CPU assembly.  Check for VMAIN and VIN on CPU assembly (see "Testing the Power Supply" at the end of this chapter). If only VIN missing, replace CPU assembly. If both missing, replace rectifier assembly.
Cardiograph doesn't run on battery, but runs on AC.	Low battery or defective battery.  Battery fuse (F2) is blown.  Battery charger is defective. Battery switch is defective.	Charge or replace battery.  Check for VBAT and VBAT+ on CPU assembly. Replace fuse if VBAT is not present. Replace CPU assembly. Check for VIN when the <b>On-Standby</b> key is pressed. Replace CPU assembly if VIN is not present.

Table 6-2. Power Supply and Battery (continued)

Symptom	Cause	Corrective Action
Cardiograph doesn't run on AC, but runs on battery.	Voltage selector switch set to wrong voltage. AC fuse is blown. ACON connector (J8) not plugged in. Rectifier assembly, transformer, AC switch, power line module, or power cord defective. VIN fuse (F1) is blown. Input protection transistor is defective.	Set switch to correct voltage. Replace AC fuse. Plug in ACON connector. Check for VMAIN and replace appropriate assembly to restore VMAIN. Check for VMAIN and VIN. If VIN is not present, replace CPU assembly. Check for VMAIN. If not present, replace CPU assembly.
Cardiograph won't power up on AC or battery.	User interface cable is defective. Keyboard circuit board is defective. VBACK regulator is defective. +5 volt regulator is defective.	Replace the user interface cable. Replace the user interface assembly. Replace CPU assembly. Replace CPU assembly.
Battery charge level indicator never indicates full capacity.	Battery not fully charged.  Battery is defective. Keyboard circuit board is defective. Battery fuse (F2) or VIN fuse (F1) (or both) defective. Battery charger is defective. CPU assembly is defective. Indicator is not updated.	With unit plugged into AC power, turn on unit and observe battery level indicator. If all green lights are on, battery is fully charged. If some green lights are not on, battery needs further charging. Replace battery. Replace the user interface assembly. Replace fuse(s). Replace CPU assembly. Replace CPU assembly. Connect to AC power and power on.
Battery charge level indicator always indicates full capacity on AC power with battery.	Keyboard circuit board is defective.  Battery is defective. Battery fuse (F2) is open. CPU assembly is defective.	Replace user interface assembly if Extended Self-test keyboard test shows LED is out. Replace battery. Replace fuse. Replace CPU assembly.

**Note**



Only the M1700A and M1701A patient modules feature a display and a start button.

Note



---

When dealing with noise problems, remember that most noise is the result of faulty operator technique or poor quality electrodes. If noise persists after checking the electrode placement and other elements of operator technique, the noise may be the result of faulty leadwires. Only when you eliminate technique and leadwires as the causes of the noise should you consider replacing the patient module.

---

Tip



---

The leadwire status indicators on the patient module and the leadwire shorting plugs can be used as a troubleshooting aid. With the SAECG patient module, these indicators are only active until the **Start** key is pressed.

---

Table 6-3. Patient Module and Patient Data Cable

Symptom	Cause	Corrective Action
No display on patient module LCD M1700A & M1701A only.	Incorrect contrast adjustment. Patient data cable or cable connectors. Defective patient module. Defective part on CPU assembly.	Adjust contrast. Tighten if loose, replace if damaged or defective. Replace patient module. Replace CPU assembly.
"Leads off" displayed on preview screen, but patient module appears blank or shows stars, blanks, and boxes.	Loose or defective patient data cable, cable connectors. Defective patient module. Defective part on CPU assembly. Averaging in SAECG.	Check cable and connectors for damage. Tighten connectors as necessary. Replace damaged cable. Replace patient module. Replace CPU assembly. None (stars normally appear during averaging).
"Leads off" not indicated when wire is off.	Dirty contacts on patient module for leadwires. Defective patient module. Defective or dirty leadwire.	Ensure the contacts on the patient module are clean and dry. Replace patient module. Clean and switch to isolate defective leadwire. Replace defective leadwire.
"Leads off" indicated when wire is not off.	Poor electrode contact. Defective leadwire.	Improve patient preparation. Remove leadwire and install shorting plug. If "leads off" isn't indicated, replace leadwire; if "leads off" is indicated, replace the patient module.
No response to start button (M1700A & M1701A only).	Cardiograph busy. Insufficient pressure on start button. Defective patient module. Suspect patient module if cardiograph starts from front panel but not from patient module button. Cardiograph is in SAECG mode (start button is not active in this mode).	Verify cardiograph is not in configuration mode or busy. Push harder. Replace patient module. None.
All "Leads Off" printed on a copy of M1702A ECG. (M1702A only)	ROM Software Defect. A.01.00 Patient was disconnected before copy button was pressed.	Install A.01.01 (or later) Revision ROM.

Table 6-3. Patient Module and Patient Data Cable (continued)

Symptom	Cause	Corrective Action
Bad ECG: Good calibration pulse in channel(s) where trace(s) is(are) not good.	Faulty operator technique; poor electrode contact.	Refer to Table 6-1 in user's manual.
	Defective leadwires. Defective patient module.	Isolate defective leadwires and replace. Replace patient module.
A lead is missing—dotted line on trace.	Faulty operator technique; poor electrode contact.	Refer to Table 6-1 in user's manual.
	Defective leadwires. Defective patient module.	Isolate defective leadwires and replace. Replace patient module.
Noisy lead(s): "AC" (regular pattern)—for 60 Hz, 12 peaks/5 mm at 25 mm/sec; for 50 Hz, 10 peaks/5 mm.	Faulty operator technique; poor electrode contact.	Refer to Table 6-1 in user's manual.
	Patient or patient module cable near AC power.	Reposition patient module cable. Try plugging cardiograph into AC outlet.
Noisy lead(s): Muscle artifact.	Patient is not relaxed or skin has been irritated.	Refer to Table 6-1 in user's manual.
	Low quality disposable electrodes, leadwire adapters.	Replace disposable electrodes or leadwire adapters. Test with ECG simulator. Replace defective leadwire(s). If none defective, replace patient module.
Noisy lead(s): I, III, aVL	LA leadwire defective.	Replace LA leadwire.
Noisy lead(s): II, III, aVF	LL leadwire defective.	Replace LL leadwire.
Noisy lead(s): I, II, aVR	RA leadwire defective.	Replace RA leadwire.
Noise in only one V lead.	Faulty operator technique; poor electrode contact.	Refer to Table 6-1 in user's manual.
	Defective leadwires.	Isolate defective leadwires and replace.
Noise in general.	Faulty operator technique; poor electrode contact.	Refer to Table 6-1 in user's manual.
	Defective leadwires.	Isolate defective leadwires and replace.

**Table 6-4. CPU Assembly (CPU, FGA, ROM, RAM)**

Symptom	Cause	Corrective Action
System won't turn on, battery installed and OK.	Defective CPU assembly.	Replace CPU assembly.
System turns on but won't run. Power supplies OK.	Stored software corrupt. Defective CPU assembly.	Reinstall software. Replace CPU assembly.

Table 6-5. Printer

Symptom	Cause	Corrective Action
Paper doesn't move; printer error message displayed Check paper supply.	Paper out or jammed.  Defective motor/sensor cable assembly. Defective motor assembly. Defective motor drive assembly. Defective roller.	Replace paper or clear paper jam.  Replace motor/sensor cable assembly. Replace motor assembly. Replace CPU assembly. Replace printer door assembly.
Paper moves then stops and displays an error message. Check paper supply.	Paper loaded incorrectly.  Dirty sensor lens. Defective sensor. Defective motor/sensor cable assembly. Defective sensor circuit. Defective roller.	Make sure cardiograph is loaded properly with approved thermal paper.  Clean sensor lens. Replace sensor assembly. Replace motor/sensor cable assembly. Replace CPU assembly. Replace printer door assembly.
Paper stops in the wrong place after pressing <b>Page Advance</b> or <b>Auto</b> . No error message.	Wrong type of paper.  Dirty sensor lens. Defective sensor. Defective motor/sensor cable assembly. Defective sensor circuit.	Make sure cardiograph is loaded properly with approved thermal paper.  Clean sensor lens. Replace sensor assembly. Replace motor/sensor cable assembly. Replace CPU assembly.
Wavy diagonal lines in printer self-test or distortion of printouts in the time axis.	Improper meshing of gears in motor assembly or door assembly.	Replace motor or door assembly.
Message: Printer door open.	Door is ajar.  Printhead bail or leaf spring touching contact post. Defective sensor assembly. Defective motor/sensor cable assembly. Defective door-detect circuit.	Close door.  Check leaf spring behind printhead and contact post. Replace sensor assembly. Replace motor/sensor cable assembly. Replace CPU assembly.

Table 6-5. Printer (continued)

Symptom	Cause	Corrective Action
Paper moves but nothing prints.	Paper loaded incorrectly, or non-approved or non-thermal paper installed.	Make sure cardiograph is properly loaded with approved thermal paper.
Printer moves but printing is faint.	Door improperly latched. Paper loaded incorrectly, or non-approved or non-thermal paper installed. Insufficient leaf spring tension or printhead out of position. Defective printhead or printhead cables. Defective component in printer circuitry. Selector S1 on CPU set incorrectly.	Check door latch. Make sure cardiograph is properly loaded with approved thermal paper. Check leaf spring for printhead platen pressure, door latch. Check for proper paper. Replace printhead assembly. Replace CPU assembly. Set selector S1 correctly (refer to Chapter 7).
Printed data is garbled.	Defective printhead. Defective component in data path.	Replace printhead assembly. 1. Check printhead cables. 2. Replace CPU assembly.
Poor print quality or some dots not printing.	Dirty printhead. Loose ESD brush fibers. Incorrect printhead or sensor cable dress. Defective printhead or printhead cables. Defective component in printer circuitry.	Clean printhead. Remove loose brush fibers and clean printhead. Correct cable dress so that printhead assembly moves properly. Replace printhead assembly. Replace CPU assembly.
Some dots always on.	Defective printhead.	Replace printhead assembly.
Printing is dark on one side of page but faint on the other side.	Printhead is not free to float and provide even (uniform) pressure distribution across platen roller.	Correct binding condition. Replace printer door. Replace printhead assembly.

Table 6-6. Disk Drive (M1700A and M1701A only)

Symptom	Cause	Corrective Action
Disk drive inoperative.	Power problems.	Check power supply. Check disk drive power cable and plugs.
Error message Try new disk appears.	Defective cables, plugs.  Defective disk. Defective drive. Hardware problems on CPU assembly. Unit is jarred while storing to disk.	Check cables, plugs.  Try known good disk. Replace. Replace CPU assembly.  Do not move unit during disk operations (while yellow disk drive light is on).
Fails Extended Self-test disk drive test.	Defective disk used for test.  No disk in drive. Disk write protected. Wrong disk density. Defective cable. Defective disk drive. Defective CPU assembly.	Replace disk and retry.  Insert disk in drive and retry. Change write protection on disk. Use 1.44 MB disk. Replace cable and retry. Replace disk drive. Replace CPU assembly.

Note



---

Follow these rules to keep your flexible disks and their stored files in good condition.

- Never manually open the silver shutter on the disk.
- Do not expose the disk to direct sunlight, extremes of temperature or humidity, magnetic fields, or dust.
- Place the disk in a protective cover when the disk is not inside the drive.
- Store disks in a clean, dry place.
- Clean the disk drive with a wet-dry cleaning kit regularly. Wet-dry cleaning kits are available from local computer stores.

Clean the disk drive every six months unless the working environment is particularly dusty or dirty. Clean the drive more often in dusty or dirty environments.

TraceMaster ECG Management System users:

If you transfer ECGs to the TraceMaster System by disk, clean the TraceMaster drive every six months unless the working environment is particularly dusty or dirty. Clean the drive more often in dusty or dirty environments.

- Replace disks regularly. The recommended replacement interval is every three months. If the disks are used for more than 50 ECGs per day, replace the disks more frequently.
  - For best results, use only Hewlett-Packard recommended disks. (HP part number M1700-89004)
  - For more information, contact your Hewlett-Packard service representative.
-

Table 6-7. Preview Display and Logic (M1700A)

Symptom	Cause	Corrective Action
Washed out display.	Improper brightness or contrast adjustment or both.	Adjust brightness and contrast controls for best display appearance.
All white screen, backlights on.	Contrast or brightness or both misadjusted. Interconnect cable between preview logic and display unplugged or defective. Defective preview logic board. Defective preview power supply board. Defective LCD module. Missing supply voltages to power supply and LCD module.	Adjust contrast or brightness or both. Check that plug is fully connected. Replace cable if defective. Replace board. Replace board. Replace LCD module. Verify presence of VCC and VIN at input to power supply board. Refer to Appendix A for pin assignments. Verify presence of VCC, VLCD, VCFL at power supply board output.
No brightness adjust.	Defective brightness potentiometer or defective power supply board.	Replace power supply board.
No contrast adjust.	Defective contrast potentiometer or defective power supply board.	Replace power supply board.
All black screen.	Contrast or brightness misadjusted. Defective preview logic board. Defective LCD module. Defective CPU assembly.	Adjust contrast. Replace board. Replace display assembly. Replace CPU assembly.
All blue screen.	Defective preview logic board. Defective preview power supply board.	Replace board. Replace board.
Screen is blank.	M1701A software loaded on an M1700A.	Load correct software.

**Table 6-7. Preview Display and Logic (M1700A) (continued)**

Symptom	Cause	Corrective Action
Backlight flickers. Half screen lit. No backlight but characters present.	Brightness misadjusted.	Adjust brightness knob for proper brightness level.
	Bad connection at preview power supply board J1.	Check that backlight cable is securely connected.
	Burned out or weak backlight bulb(s). Defective power supply board.	Replace LCD module. Replace board.
Garbled data on display.	Interconnect cable between preview logic and display unplugged or defective.	Ensure that plug is fully connected. Replace cable if defective.
	Defective preview logic board.	Replace board.
	Defective CPU assembly.	Replace CPU assembly.

**Table 6-8. Keyboard and Keyboard Display (LCD)**

Symptom	Cause	Corrective Action
Display stays blank.	Contrast or brightness misadjusted.	Adjust contrast or brightness.
	No +5 volts due to defective interconnect cable.	Replace cable assembly. Test power supply.
	Defective LCD assembly Defective 5 volt regulator in main power supply.	Replace user interface assembly. Replace CPU assembly.
Keys won't work. Unable to enter data or operate controls.	Interconnect cable unplugged or defective.	Reconnect or replace cable.
	Keyboard circuit board defective.	Replace user interface assembly.
	CPU assembly defective.	Replace CPU assembly.

Table 6-9. Transmit and Modem

Symptom	Cause	Corrective Action
Message: Data transmission abnormal termination.	Error 1540	See "Errors" earlier in this chapter.
	Error 1541	See "Errors" earlier in this chapter.
Message: ERROR 153x: Remote site failure.	Covers errors 1532, 1533, 1534, 1536, and 1537. The remote site is terminating the link and has sent the message to inform the local user.	None
Message: No answer at site.	Cabling problems between modem and cardiograph. Telephone line or telephone cable defective.	Perform Extended Self-test modem test. Substitute normal telephone for modem and dial number. Ensure that modem answers with high-pitched tone.
Extended Self-test modem test failure	RS-232 cable not plugged in or defective. Power cable not plugged in or defective, or cardiograph AC off. Modem not turned on.  Defective modem. Defective CPU assembly.	Plug in to cardiograph; if defective, replace. Plug in to cardiograph and turn on AC; if defective, replace. Turn on modem. If modem is turned on, or if unit is a fax modem, check for unplugged or defective power cable. Replace modem. Replace CPU assembly.
Unable to transmit or receive. Modem passes Extended Self-test.	Phone cable unplugged or defective.  Defective modem. Defective CPU assembly.	Plug in phone cable; if defective, replace.  Replace modem. Replace CPU assembly.

## Testing the Power Supply

Use this procedure to check the voltages produced by the power supply. The cardiograph must be connected to AC power to test all the power supply voltages. All the voltage measurements are taken with respect to ground. Refer to Figure 6-3 for voltage test point locations.

### Warning



When the cardiograph is connected to AC power, there are dangerous voltages on the line module terminals, even when the AC switch is off. When the AC switch is on, there are also dangerous voltages on the terminals of the mains transformer. If you must have the AC power connected while the cardiograph is open, do not touch any of the exposed connectors.

The rectifier assembly capacitors store hazardous amounts of energy during AC and battery operation. Be careful not to touch any of the exposed capacitor connections.

1. Open the top cover assembly as described in Chapter 7, "Removal and Replacement."
2. Make sure the cardiograph is connected to AC and that the AC switch is on. Then pull out the battery enough to disconnect it.

### Caution



Be very careful to not short VIN to ground or to other pins. This will result in cardiograph failure.

3. Measure VIN. It should read approximately 24 V DC. The presence of this voltage confirms the proper operation of the mains transformer and the rectifier assembly under light load.
4. Measure VBAT+. It should read approximately 21 to 22 volts. This voltage confirms the proper operation of the battery charger.
5. Measure VBACK through the opening in the shield at the tab on transistor Q5 (see Figure 6-3). It should read +5 V DC. Its presence confirms the proper operation of the backup 5 volt supply.

**Note**

---

The battery voltage can be read on the keyboard display using the following sequence, starting from Standby:

- a. Press the **On-Standby** key (to turn on the cardiograph).
- b. Immediately press and hold the **Alt** key.
- c. Press the **V** key (for "Voltage").
- d. Release the **Alt** and **V** keys simultaneously.

The battery voltage will be displayed briefly in the center of the keyboard display. The battery voltage should be slightly higher when the cardiograph is operating on AC (AC LED is on), indicating that the battery is charging.

---

6. Install the battery and turn off the AC switch.
7. Measure VBAT+ again. If the battery is fully charged, the voltage should measure 19 to 20 volts.
8. Press the **On-Standby** switch to turn the cardiograph On.
9. Measure +5V. It should read +5 V DC. Its presence confirms the proper operation of the +5 volt supply.
10. Measure VFE at pin 5 of the ECG Input connector, J9. It should read approximately 11 volts. Its presence confirms the proper operation of the VFE regulator circuit that supplies power to the patient module.
11. Measure VPRINT. It should read approximately the same as VBAT+. Its presence confirms the proper operation of the printer switch circuit.
12. Measure VMOTOR. It should measure 15.6 to 17.9 V DC. Its presence confirms the proper operation of the regulator that supplies power to the motor.
13. Carefully measure VIN (see the CAUTION at step 3). VIN should read approximately one volt less than VBAT+. Its presence confirms the proper operation of the battery switch circuit.
14. Turn on the AC switch.
15. Measure VBAT+. It should read between 19 and 22 volts for a fully charged battery.
16. Carefully measure VIN again. It should read between 17 and 31 V DC. This confirms the operation of the mains transformer and the rectifier assembly under full load.
17. Close the top cover assembly.

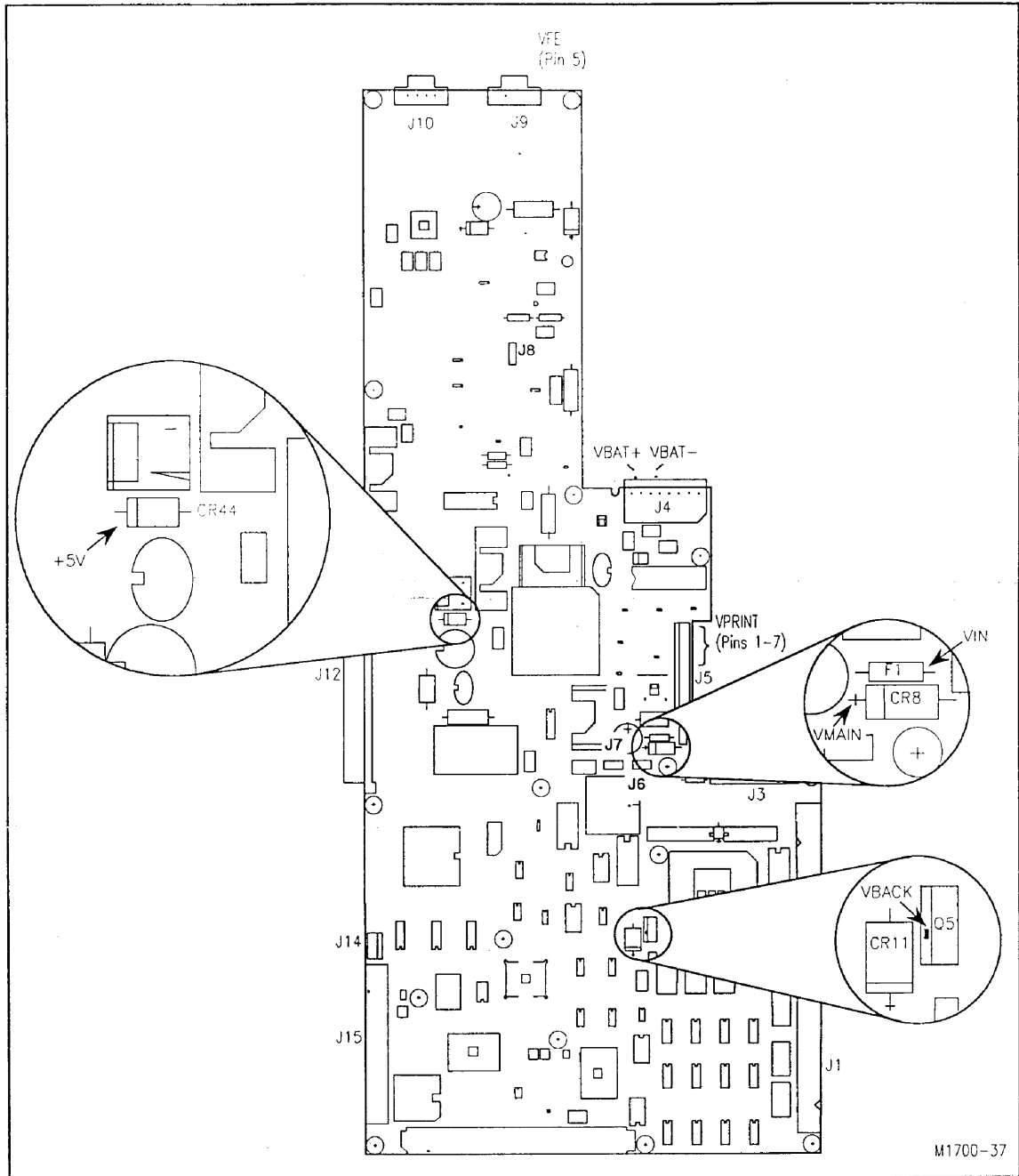

Figure 6-3. Voltage Test Locations.

## Removal and Replacement

---

### Introduction

This chapter contains procedures for removing and replacing these cardiograph subassemblies:

- The battery
- The keyboard and the user interface assembly
- The printer drive assembly
- The preview screen assembly (M1700A only)
- The top cover assembly
- The printhead assembly
- The preview logic board (M1700A only)
- The CPU assembly
- The disk drive (M1700A and M1701A only)

### Note



As of February 1992, all new PageWriter XL cardiographs are manufactured to a revised mechanical design specification. All units having a serial number prefix of 3208A or later conform to this revised specification.

This chapter contains procedures for all PageWriter XL cardiographs. The particular procedure you will use depends on the serial number prefix of the PageWriter you are servicing. Make sure you use the correct procedure for your particular cardiograph.

### Note



The way in which wires and cables are routed and dressed inside the main chassis plays an important part in reducing electromagnetic and radio frequency interference emitted by the cardiograph. When you disassemble any part of the cardiograph, pay special attention to the way cables and wires are routed and dressed. When you reassemble the cardiograph, be sure to route and dress all cables and wires as they were originally.

## Tool Requirements

These are the tools you need to remove and replace the cardiograph's subassemblies:

- 7/32-inch nut driver
- Small flat-bladed screwdriver
- T10 and T15 Torx drivers (or Torx driver kit, HP part number 5181-1933)
- Long-nose pliers (recommended, but not necessary)

## Note



The directions in this chapter generally assume you are facing the front of the cardiograph as you work. Thus, for example, the "left side of the cardiograph" means "the left side as you face the front of the unit."

---

## The Battery

This section explains how to remove and replace the battery. These procedures apply to all units.

### Removing the Battery

To remove the battery:

## Caution



To prevent the loss of data (including the configuration and software) stored in system memory, the cardiograph must be connected to AC with the AC switch turned on when the battery is removed.

If you are servicing an M1700A or M1701A PageWriter, store the configured software on disk as described in "Configuration Files" in Chapter 2. If you are servicing an M1702A PageWriter, print a copy of the cardiograph configuration (see Chapter 2). Doing this will help you reconfigure the PageWriter when power is reapplied.

1. Connect the power cord to the cardiograph, then plug the cord into an AC outlet.
2. Turn on the AC switch on the back of the cardiograph and check that the AC indicator on the front panel is lit.
3. Open the battery compartment by loosening the two captive thumbscrews on the back of the cardiograph as shown in Figure 7-1 (the figure shows the M1700A).

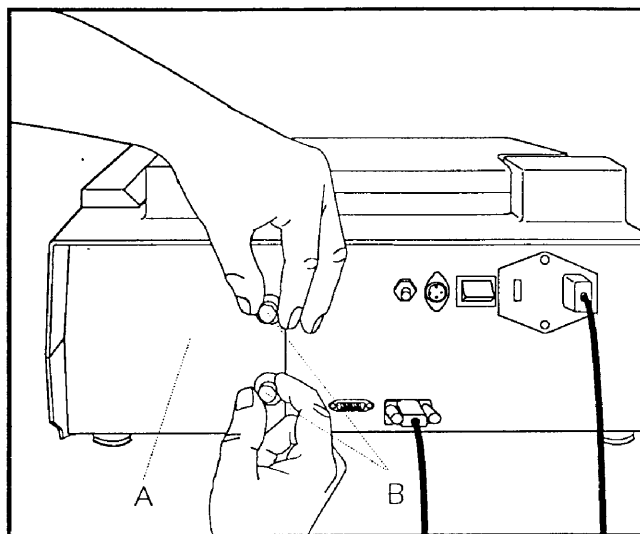

Figure 7-1. Opening the Battery Compartment.

- A. Battery door
- B. Thumbscrews

Warning



The battery is relatively heavy for its size. Support the battery from underneath as you remove it to prevent it from slipping and possibly causing injury.

4. Slide the battery and battery holder out of the cardiograph.
5. Separate the battery holder from the battery and set the battery aside for storage or proper disposal.

Warning



Dispose of or recycle depleted batteries according to local regulations. Do not disassemble, puncture, or incinerate the battery assembly.

## Replacing the Battery

To replace the battery:

1. Install the battery in the battery holder. Make sure the tab on the holder fits into the slot on the battery as shown in Figure 7-2.

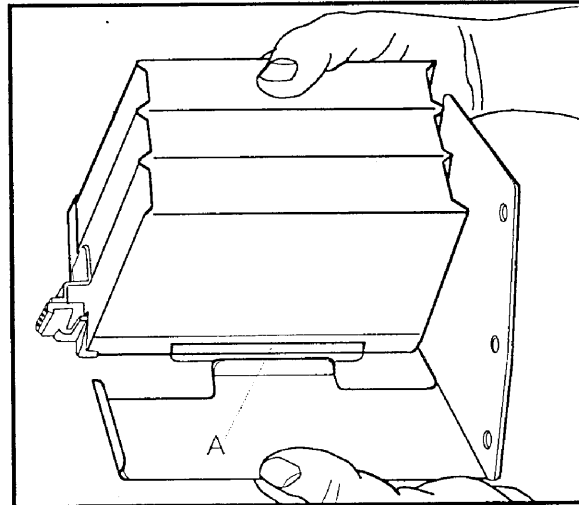

Figure 7-2. Fitting the Battery Holder Tab Into the Battery Slot.

- A. Battery slot
2. Gently slide the battery and holder into the battery compartment until completely seated.
3. Finger-tighten the thumbscrews on the battery holder.
4. Press the **On-Standby** switch to turn the cardiograph **On**.
5. Check that the AC indicator and one or more battery level indicators are lit.

### Note



To insure full battery capacity, charge the battery for 24 hours after you install it in the cardiograph. The battery will charge as long as the cardiograph is connected to AC and the AC switch is on.

### Note



To verify battery capacity, turn on the unit while the cardiograph is connected to AC power and the AC switch is on. It is important that the cardiograph is connected to AC power when verifying battery capacity.

---

## The Keyboard and the User Interface Assembly

This section explains how to remove and replace the keyboard and the user interface assembly. These procedures apply to all units.

### The Keyboard

The keyboard is mounted on the front of the cardiograph in the user interface assembly. To remove the keyboard, carefully insert a flat-bladed screwdriver into the slots and pry as shown in Figure 7-3. To reinstall the keyboard, snap it back in place.

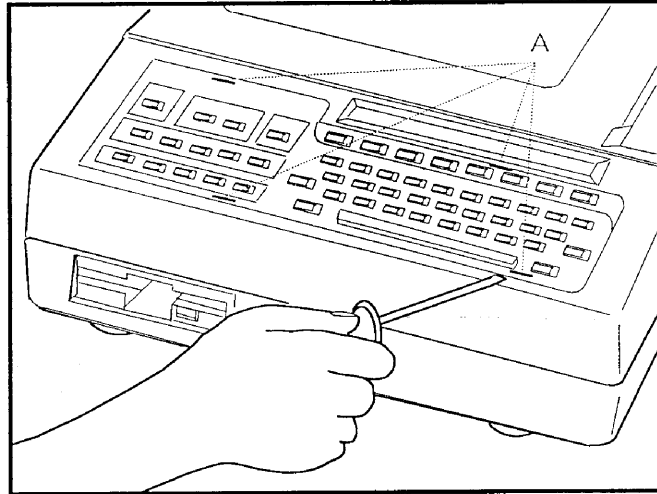

Figure 7-3. Removing the Keyboard.

A. Pry slots

### The User Interface Assembly

The user interface assembly consists of the main bezel, the keyboard PCB, and the front panel display.

#### Removing the User Interface Assembly

#### Caution



---

Use an electrostatic wrist band or other approved method for protection against electrostatic discharge when handling the interface assembly.

---

To remove the user interface assembly:

1. Set the cardiograph to **Standby**.
2. Remove the keyboard.

3. Remove the six screws shown in Figure 7-4.

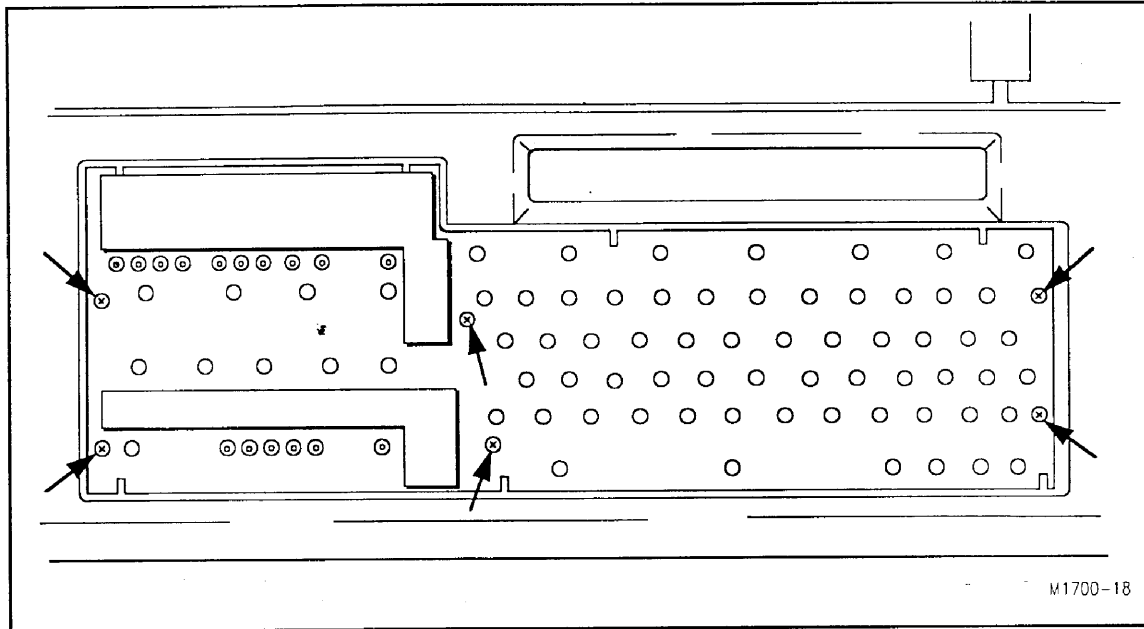

Figure 7-4. User Interface Screw Locations.

4. Carefully lift the assembly and tilt it until the keyboard and LCD circuit boards are accessible.
5. Disconnect the ribbon cables from the circuit boards.

**Caution**



Do not remove the circuit boards from the user interface assembly. Removing the boards can impair the long-term reliability of the cardiograph.

**Replacing the User Interface Assembly**

To replace the user interface assembly, reverse the above procedure.

---

## The Printer Drive Assembly

This section describes how to remove and replace the printer drive assembly.

### Removing the Printer Drive Assembly

The procedure you will use depends on the serial number prefix of the unit you are servicing. Make sure you use the correct procedure for your particular unit.

#### PageWriters with Serial Number Prefix 3208A or Later

If the PageWriter has a serial number prefix of 3208A or later, use this procedure to remove the printer drive assembly.

To remove the printer drive assembly:

1. Remove the keyboard and the user interface assembly as described previously in this chapter.
2. Remove the printer door:
  - a. Release the latch and pull the door out to the first stop.
  - b. Compress and remove the plastic retainer clip at the end of the rear plastic rail.
  - c. Slide the door out of the rails and set it aside.
3. Lift off the printhead cover as shown in Figure 7-5. As you lift off the cover, note how the tabs on the printhead cover interlock with the other plastic parts of the top cover.

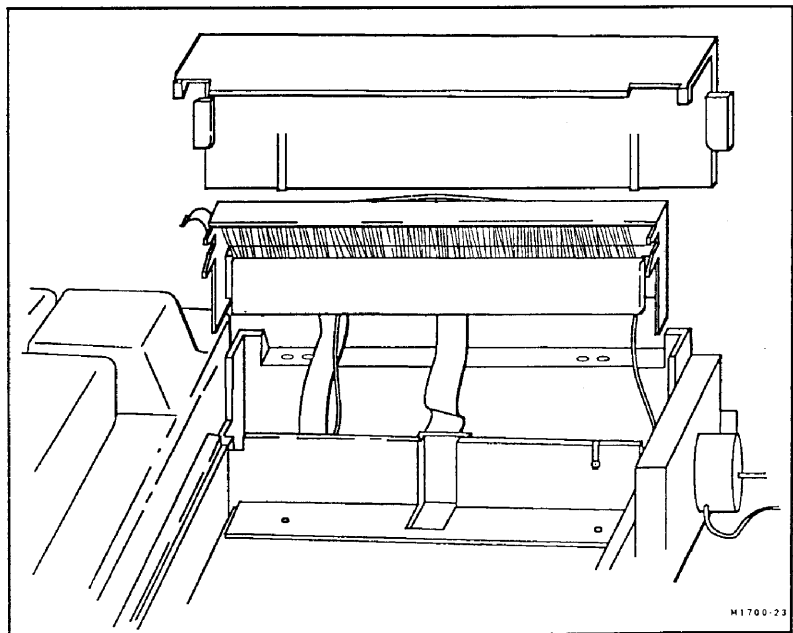
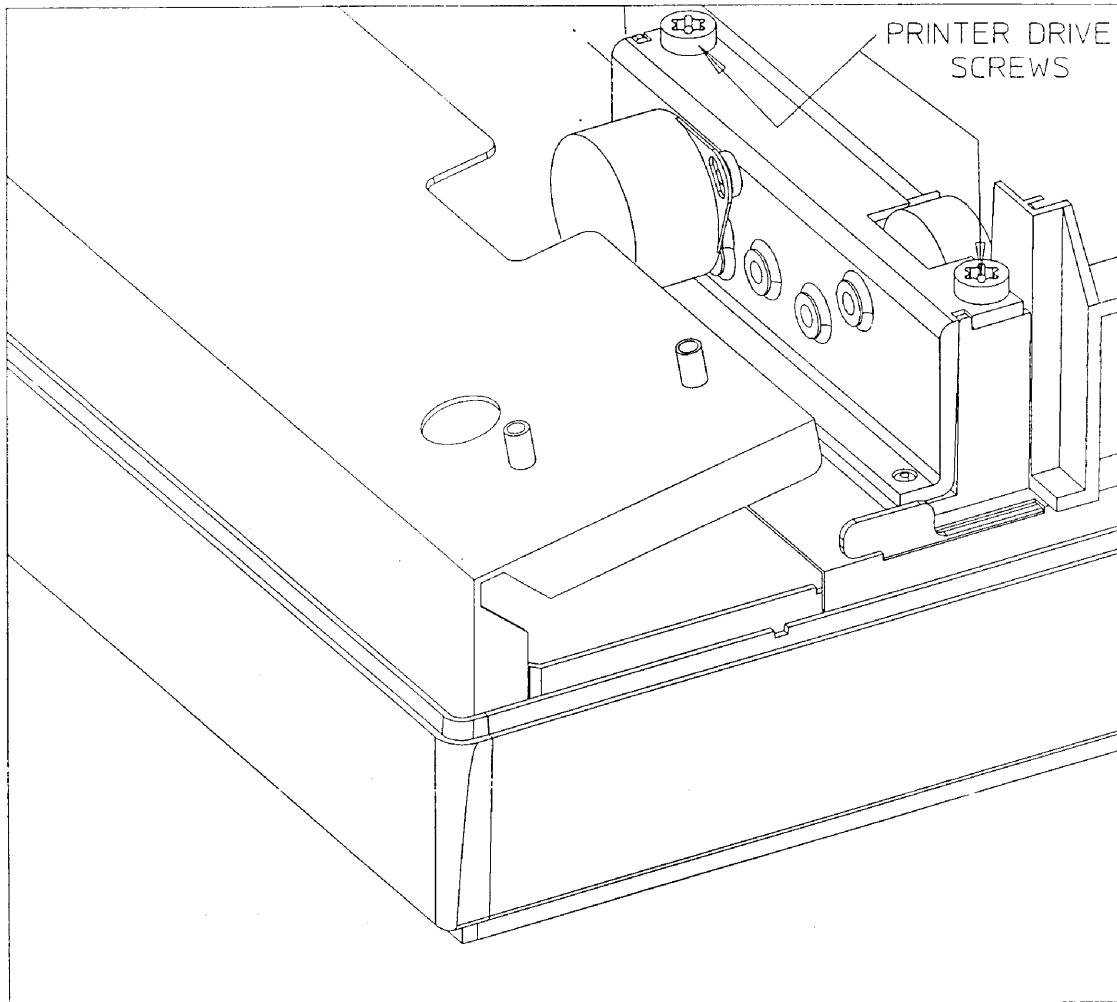

Figure 7-5. Removing the Printhead Cover.

4. Disconnect the motor and sensor connectors.
5. Remove the two screws (see Figure 7-6) that attach the plastic gear housing to the cardiograph.



**Figure 7-6. Printer Drive and Keyboard Ground Plane Screw Locations.**

6. Carefully pry up the plastic gear housing to free it from the alignment pins on the cardiograph. If the gears fall off their shafts, refer to the first step in the printer drive replacement procedure that follows.

## 7-8 Removal and Replacement

### PageWriters with Serial Number Prefix Prior to 3208A

If the PageWriter has a serial number prefix prior to 3208A, use this procedure to remove the printer drive assembly.

To remove the printer drive assembly:

1. Remove the keyboard and the user interface assembly as described previously in this chapter.
2. Remove the printer door:
  - a. Release the latch and pull the door out to the first stop.
  - b. Compress and remove the plastic retainer clip at the end of the rear aluminum rail.
  - c. Slide the door out of the rails and set it aside.
3. Lift off the printhead cover as shown in Figure 7-7. As you lift off the cover, note how the tabs on the printhead cover interlock with the other plastic parts of the top cover.

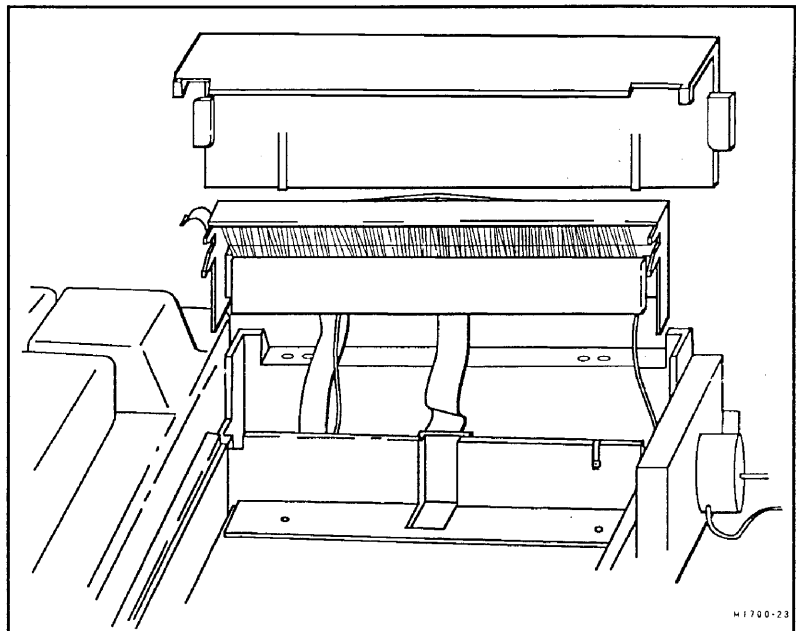

Figure 7-7. Removing the Printhead Cover.

4. Remove the four screws that attach the keyboard ground plane to the upper chassis and set the keyboard ground plane aside. Callout D in Figure 7-8 shows two of the screws.

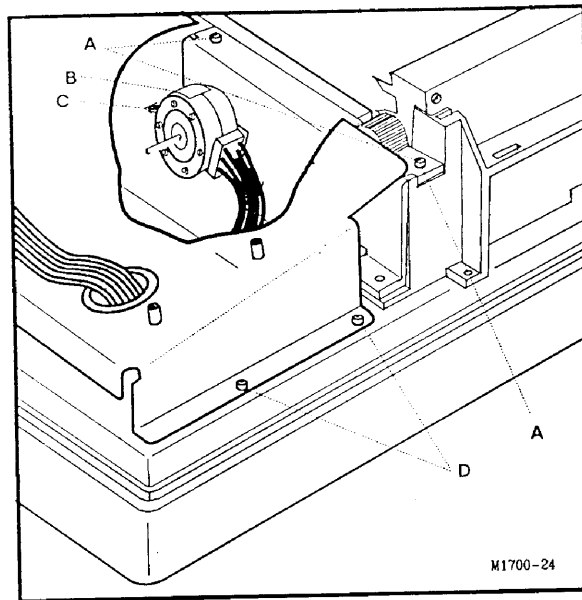

Figure 7-8. Printer Drive and Keyboard Ground Plane Screw Locations.

- A. Gear housing screws
  - B. Motor ground spring
  - C. Motor ground spring attaching screw
  - D. Keyboard ground plane screws (two of four)
5. Remove the screw (callout C in Figure 7-8) that attaches the motor ground spring to the upper chassis.
  6. Disconnect the motor and sensor connectors.
  7. Remove the two screws (callout A in Figure 7-8) that attach the plastic gear housing to the cardiograph.
  8. Carefully pry up the plastic gear housing to free it from the alignment pins on the cardiograph. If the gears fall off their shafts, refer to the first step in the printer drive replacement procedure later in this chapter.

## 7-10 Removal and Replacement

## Replacing the Printer Drive Assembly

Use this procedure to replace the printer drive assembly. This procedure applies to all units.

To replace the printer drive assembly:

1. If necessary, reinstall the gears. The gears are arranged on the shafts in the gear housing as shown in Figure 7-9. Each gear has a number molded into it. That number corresponds to a number molded into the gear housing next to the appropriate shaft. Insert gears with molded numbers facing up.

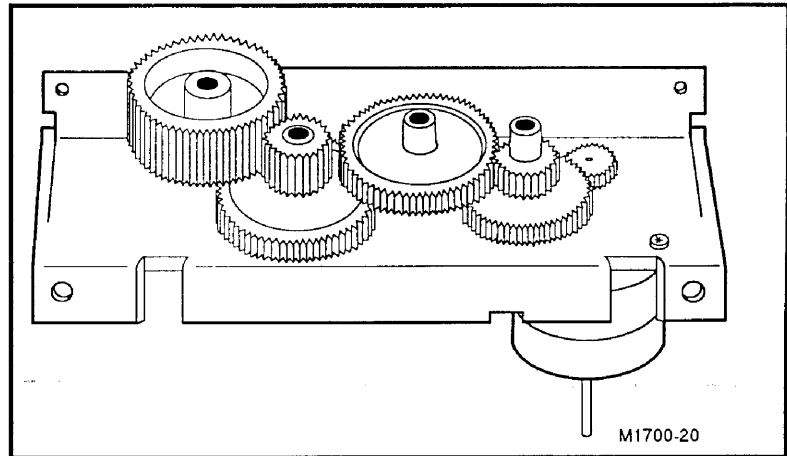

Figure 7-9. The Printer Drive Gears.

2. Press the gear housing onto the alignment pins.
3. Reinstall the two gear housing screws.
4. Reconnect the motor and sensor connectors.

### Note



The motor ground spring (callout B in Figure 7-8) and the motor ground spring attaching screw (callout C) were not included on units having a serial number prefix of 3208A, and may be left off.

5. On models having a serial number prefix prior to 3208A, reinstall the motor ground spring and its attaching screw, and reinstall the keyboard ground plane.
6. Reinstall the printhead cover.
7. Reinstall the printer door and the retainer clip.
8. Reinstall the user interface assembly and the keyboard.

---

## The Preview Screen Assembly

This section describes how to remove and replace the preview screen assembly.

### Note



---

PageWriters having a serial number prefix of 3208A or later have a new design that allows easier component-level repair of the preview screen assembly.

---

## Removing the Preview Screen Assembly

The procedure you will use depends on the serial number prefix of the unit you are servicing. Make sure you use the correct procedure for your particular PageWriter.

When you remove the preview screen assembly, you can either disassemble it completely, or you can remove the assembly as a single piece that includes the clutches and cables. (The complete replacement preview assembly also includes clutches and cables.) This section includes instructions for removing the preview assembly as a whole and for disassembling it.

### PageWriters with Serial Number Prefix 3208A or Later

If the PageWriter has a serial number prefix 3208A or later, use these procedures to remove or disassemble the preview screen assembly.

**Removing the Entire Preview Screen Assembly.** Use this procedure to remove the preview screen assembly as a single unit.

### Warning



---

**Perform the following four steps sequentially to eliminate the chance of exposure to hazardous voltages.**

---

1. Disconnect the AC power cord.
2. Verify that no disk is in the disk drive.
3. Turn the cardiograph **On**. (This allows the rectifier assembly capacitors to discharge more rapidly.)
4. Remove the battery as described earlier in this chapter.
5. Remove the left and right clutch covers:
  - a. Insert a small flat-bladed screwdriver in the slot at the bottom rear of the cover and gently pry up till the catch releases.
  - b. Tilt the cover forward slightly to disengage the tabs at the front, then lift the cover away. (This is easier if the screen assembly lays flat on the PageWriter.)
6. Remove the mounting screws and washers from the left and right clutches.
7. Lift the preview screen assembly off of the cardiograph.
8. Remove the user interface as described earlier in this chapter.

9. Remove the three screws from the rear panel as shown in Figure 7-10.

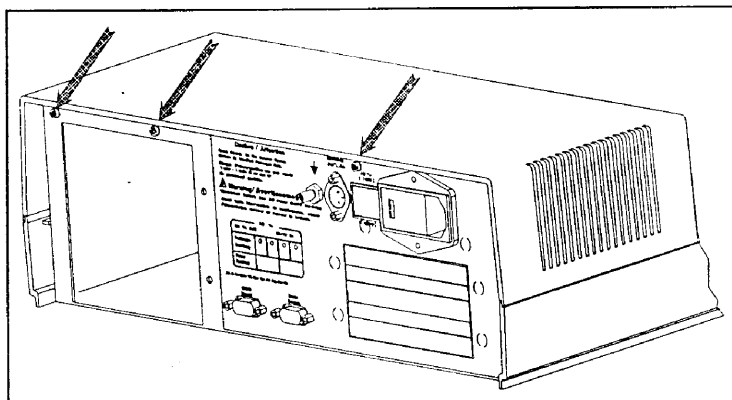

Figure 7-10. Opening and Removing the Top Cover Assembly.

10. Open the top cover and disconnect the preview cable from the preview logic board (see "Opening and Removing the Top Cover Assembly" later in this chapter).

**Disassembling the Preview Screen Assembly.** Use this procedure to disassemble the preview screen assembly.

**Warning**



**Perform the following four steps sequentially to eliminate the chance of exposure to hazardous voltages.**

1. Disconnect the AC power cord.
2. Verify that no disk is in the disk drive.
3. Turn the cardiograph **On**. (This allows the rectifier assembly capacitors to discharge more rapidly.)
4. Remove the battery as described earlier in this chapter.
5. Remove the two knobs from the front of the display.
6. Remove the left and right clutch covers:
  - a. Insert a small flat-bladed screwdriver in the slot at the bottom rear of the cover and gently pry up till the catch releases.
  - b. Tilt the cover forward slightly to disengage the tabs at the front, then lift the cover away. (This is easier if the screen assembly lays flat on the PageWriter.)
7. Remove the right clutch:
  - a. Remove the mounting screws and washers.
  - b. Slide the clutch off of the screen housing's right pivot arm. The clutch fits tightly on the pivot arm and requires effort to remove it.

8. Pull the screen housing's left pivot arm out of the left clutch and lay the screen face down on top of the cardiograph.
9. Pry off the back cover of the screen housing:
  - a. Use a small flat-bladed screwdriver to disengage the three catches on the bottom of the screen housing shown in Figure 7-11.

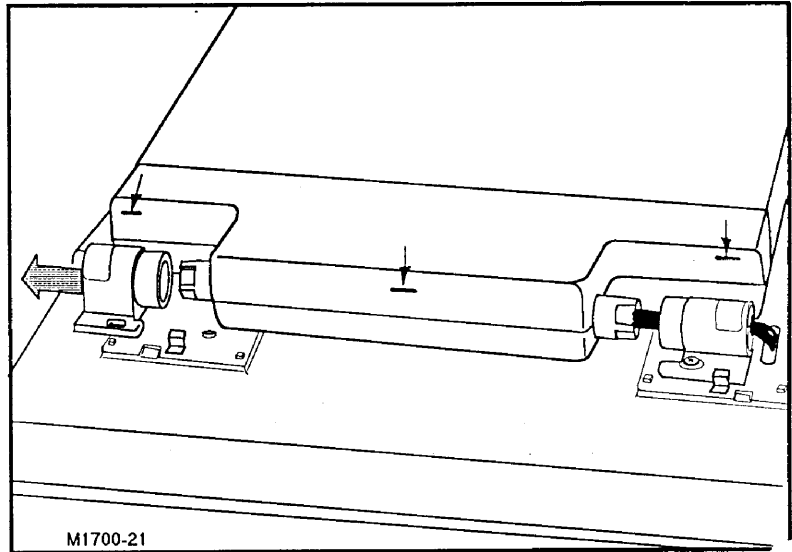

**Figure 7-11. Removing the Preview Screen Assembly.**

- b. Pivot the cover up until the catches on the top of the screen housing release.
10. Use the T10 Torx driver to remove the screw that connects the green and yellow ground wire from the display cable to the metal display frame.
11. Lift the power supply board out of the screen assembly, and disconnect the ribbon cable from the power supply board.
12. Remove the flat ribbon cable to the LCD, and set the power supply aside.
13. To remove the display screen from the assembly, remove the remaining four screws that attach the screen to its case, and lift the screen out.

#### PageWriters with Serial Number Prefix Prior to 3208A

If the PageWriter has a serial number prefix prior to 3208A, use these procedures to remove or disassemble the preview screen assembly.

**Removing the Entire Preview Screen Assembly.** Use this procedure to remove the preview screen assembly as a single unit.

#### Warning



---

**Perform the following four steps sequentially to eliminate the chance of exposure to hazardous voltages.**

---

1. Disconnect the AC power cord.
2. Verify that no disk is in the disk drive.
3. Turn the cardiograph **On**. (This allows the rectifier assembly capacitors to discharge more rapidly.)
4. Remove the battery as described earlier in this chapter.
5. Remove the left and right clutch covers:
  - a. Insert a small flat-bladed screwdriver in the slot at the bottom rear of the clutch cover and gently pry up till the catch releases.
  - b. Tilt the clutch cover forward slightly to disengage the tabs at the front, then lift it away. (This is easier if the display lays flat on the PageWriter.)
6. Remove the screws holding the ground straps on both sides.
7. Remove the mounting screws and washers from the right and left clutches.
8. Open the top cover and disconnect the preview cable from the preview logic board (see "Opening and Removing the Top Cover Assembly" later in this chapter).

**Disassembling the Preview Screen Assembly.** Use this procedure to disassemble the preview screen assembly.

#### Warning



---

**Perform the following four steps sequentially to eliminate the chance of exposure to hazardous voltages.**

---

1. Disconnect the AC power cord.
2. Verify that no disk is in the disk drive.
3. Turn the cardiograph **On**. (This allows the rectifier assembly capacitors to discharge more rapidly.)
4. Remove the battery as described earlier in this chapter.
5. Remove the left and right clutch covers:
  - a. Insert a small flat-bladed screwdriver in the slot at the bottom rear of the clutch cover and gently pry up till the catch releases.



## Replacing the Preview Screen Assembly

To replace the preview screen assembly, reverse the appropriate removal procedure.

### Note



When reinstalling the ribbon cable from the display to the power supply board, be sure not to twist the cable or the display may not operate.

---

## The Top Cover Assembly

This section describes how to remove and replace the top cover assembly. The top cover assembly includes the upper chassis and attached covers, the printer assembly, and, on the M1700A, the preview screen assembly.

To ensure your safety and prevent damage to the cardiograph, these procedures instruct you to remove the battery *and* disconnect the AC power, which means that the contents of system memory will be lost, including the configuration and software. When you reapply power to the M1700A or M1701A cardiograph, you must install the software using either the System disk supplied with the cardiograph or a custom configuration disk. Before removing the M1702A battery, print a copy of the cardiograph configuration to facilitate restoring the configuration when power is reapplied. See "Installing Software" in Chapter 2.

## Opening and Removing the Top Cover Assembly

The procedure you will use depends on the serial number prefix of the unit you are servicing. Make sure you use the correct procedure for your particular PageWriter.

### PageWriters with Serial Number Prefix 3208A or Later

If the PageWriter has a serial number prefix of 3208A or later, use this procedure to open and remove the top cover assembly.

### Note



You can service any PageWriter with a serial number prefix of 3208A or later without removing it from the cart.

To open the top cover assembly:

1. Disconnect the AC power cord.
2. Verify that no disk is in the disk drive.
3. Turn the cardiograph **On**. (This allows the rectifier assembly capacitors to discharge more rapidly.)
4. Remove the battery as described earlier in this chapter.

**Warning**



When the cardiograph is connected to AC power, there are dangerous voltages on the line module terminals, even when the AC switch is off. When the AC switch is on, there are also dangerous voltages on the terminals of the mains transformer. If you must have the AC power connected while the cardiograph is open, do not touch any of the exposed connectors.

The rectifier assembly capacitors store hazardous amounts of energy during AC and battery operation. Be careful not to touch any of the exposed capacitor connections.

5. Remove the user interface assembly as described earlier in this chapter.
6. Remove the three screws from the rear panel as shown in Figure 7-13.

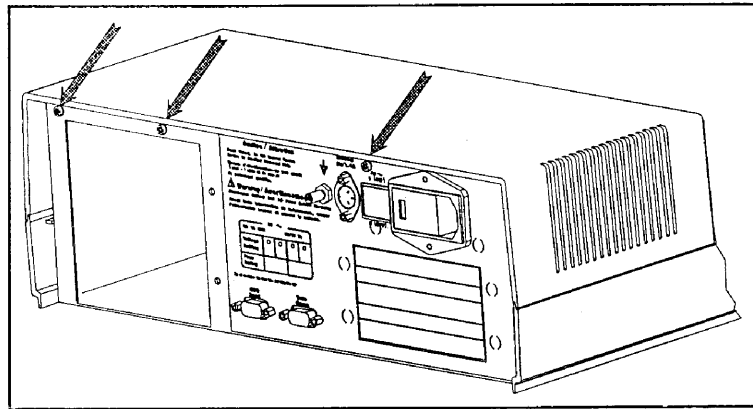

**Figure 7-13. Opening and Removing the Top Cover Assembly.**

7. Slide the top cover forward about 1 inch, then carefully lift it straight up until there is enough clearance to tilt the left side up.  
To remove the top cover assembly, continue as follows:
8. If the cardiograph is equipped with a preview display, disconnect the cable that connects the preview screen to the preview logic board and a ground wire. Disconnect the four cables and the ground wire that connect the top cover assembly to the CPU assembly.
9. Lift the top cover assembly out of the way and set it aside.

### PageWriters with Serial Number Prefix Prior to 3208A

If the PageWriter has a serial number prefix prior to 3208A, use this procedure to open and remove the top cover assembly.

To open the top cover assembly:

1. Disconnect the AC cord.
2. Turn on the cardiograph and remove the battery while the cardiograph is on. (This discharges the rectifier assembly in approximately 20 seconds.)
3. Remove the PageWriter from the cart and place it on a suitable work surface.

### Warning



When the cardiograph is connected to AC power, there are dangerous voltages on the line module terminals, even when the AC switch is off. When the AC switch is on, there are also dangerous voltages on the terminals of the mains transformer. If you must have the AC power connected while the cardiograph is open, do not touch any of the exposed connectors.

The rectifier assembly capacitors store hazardous amounts of energy during AC and battery operation. Be careful not to touch any of the exposed capacitor connections.

4. Remove the seven screws from the rear panel as shown in Figure 7-14.

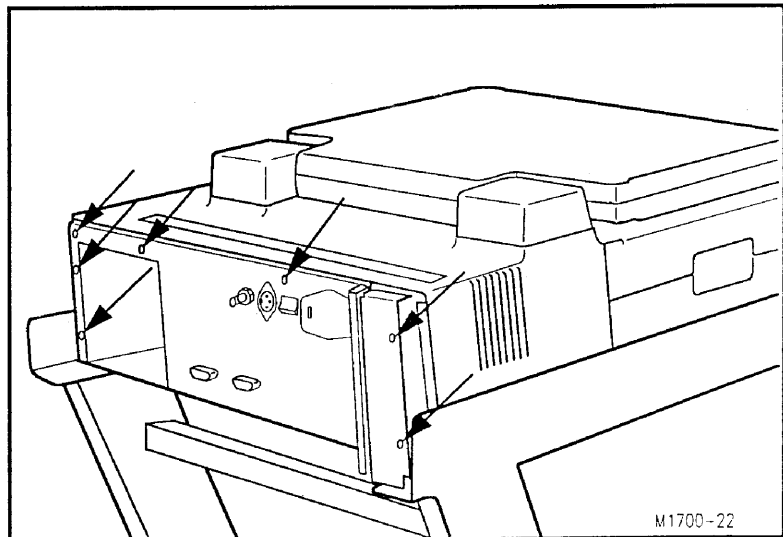

Figure 7-14. Opening and Removing the Top Cover Assembly.

5. Slide the top cover forward about 1 inch, then carefully lift it straight up until there is enough clearance to tilt the left side up.

To remove the top cover assembly, continue as follows:

6. If the cardiograph is equipped with a preview display, remove the screw that secures the cable shield wire to the preview logic RFI shield. Disconnect the cable that connects the preview screen to the preview logic board.
7. Disconnect the four cables that connect the top cover assembly to the CPU assembly.
8. Lift the top cover assembly free of the lower chassis and set it aside.

### Reinstalling the Top Cover Assembly

To reinstall the top cover assembly, reverse the appropriate removal procedure.

---

## The Printhead Assembly

This section describes how to remove and replace the printhead assembly.

### Removing the Printhead Assembly

The procedure you will use depends on the serial number prefix of the unit you are servicing. Make sure you use the correct procedure for your particular PageWriter.

#### PageWriters with Serial Number Prefix 3208A or Later

If the PageWriter has a serial number prefix of 3208A or later, use this procedure to remove the printhead assembly.

#### Caution



Use an electrostatic wrist band or other approved method for protection against electrostatic discharge when disconnecting and handling the printhead assembly.

To remove the printhead:

1. Remove the printer door:
  - a. Release the latch and pull the door out to the first stop.
  - b. Compress and remove the plastic retainer clip at the end of the rear plastic rail.
  - c. Slide the door out of the rails and set it aside.
2. Remove the user interface assembly as described previously in this chapter.
3. Open the top cover as described previously in this chapter.
4. Remove the printhead cover as shown in Figure 7-15.

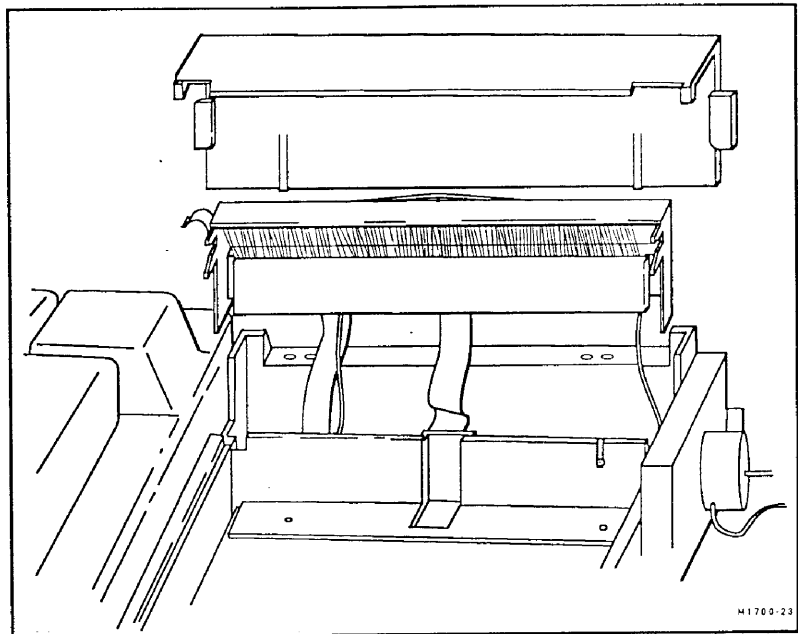

**Figure 7-15. Removing the Printhead Cover and Printhead.**

5. Disconnect the two printer cables at J2 and J5 (see Figure 7-20 for the connector locations), and remove the ground wire.
6. Close the top cover, but do not reinstall the screws. (You need to open the cover again when you install the new printhead.)
7. Pull the leaf spring up and out of its slots in the well.
8. Carefully slide the printhead assembly up and out of the printer well. Pull the two ribbon cables and the ground wire from the slots in the top cover.

**PageWriters with Serial Number Prefix Prior to 3208A**

If the PageWriter has a serial number prefix prior to 3208A, use this procedure to remove the printhead assembly.

**Caution**



Use an electrostatic wrist band or other approved method for protection against electrostatic discharge when disconnecting and handling the printhead assembly.

To remove the printhead:

1. Remove the printer door:
  - a. Release the latch and pull the door out to the first stop.
  - b. Compress and remove the plastic retainer clip at the end of the rear aluminum rail.

- c. Slide the door out of the rails and set it aside.
2. Remove the user interface assembly as described previously in this chapter.
3. Open the top cover as described previously in this chapter.
4. Remove the right side plastic cover.
5. Disconnect the two printer cables at J2 and J5 (see Figure 7-20 for the connector locations).
6. Close the top cover but do not reinstall the screws. (You need to open the cover again when you install the new printhead.)
7. Remove the printhead cover as shown in Figure 7-16.

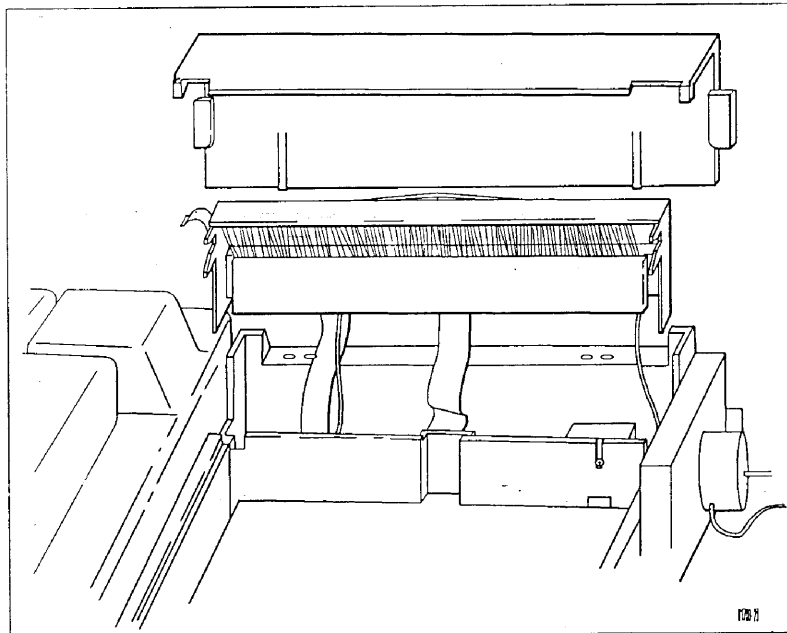

**Figure 7-16. Removing the Printhead Cover and Printhead.**

8. Remove the screws that attach the motor ground spring and printhead ground braids to the upper chassis.
9. Pull the leaf spring up and out of its slots in the well.
10. Remove the two screws holding the ground straps to the upper chassis.
11. Carefully slide the printhead assembly up and out of the printer well. Pull the two ribbon cables from the slots in the top cover.

**Removing the Optical Paper Sensor.** Remove the optical paper sensor as follows:

1. From the inside of the empty paper compartment, insert a small, flat-bladed screwdriver into the square hole (see Figure 7-16) on the surface of the plastic printhead housing.
2. Apply pressure, using the screwdriver to compress the clip that holds the lens in place, and lift the lens out.

**Note**



To remove the sensor on some units with a serial number prefix of 3023A, remove the printer from the top cover to gain access to the sensor.

**Replacing the Printhead Assembly**

Use this procedure to replace the printhead assembly. This procedure applies to all units.

To replace the printhead:

1. Unpack the new printhead. Locate the manufacturer's label behind the ESD brush fibers. Note the resistance code printed in the upper-left quadrant of the manufacturer's label. You need this code later in this procedure when you set the printhead resistance selector on the CPU assembly. The code is a number that corresponds to a range of printhead resistance, as listed in the following table.

**Table 7-1. Printhead Resistance Codes**

Code	Resistance	Code	Resistance
00	535-550 $\Omega$	08	631-640 $\Omega$
01	551-565	09	641-650
02	566-580	A	651-660
03	581-590	B	661-670
04	591-600	C	671-680
05	601-610	D	681-695
06	611-620	E	696-710
07	621-630	FF	711-725

2. Feed the power and data cables (and the ground wire on newer units) into the cardiograph assembly as you lower the printhead into position. Slide the printhead down into the printer well.
3. On PageWriters having a serial number prefix prior to 3208A, feed the ground braids to the top chassis and fasten.
4. Push the leaf spring into its slots in the well.
5. Open the top cover assembly.
6. Connect the power and data cables and the ground wire to the appropriate connectors on the CPU assembly.

7. Set selector S1 (refer to Figure 7-17) to the number or letter that corresponds to the resistance code on the printhead label. 00 corresponds to position 0, 09 corresponds to position 9, FF corresponds to position F, etc.

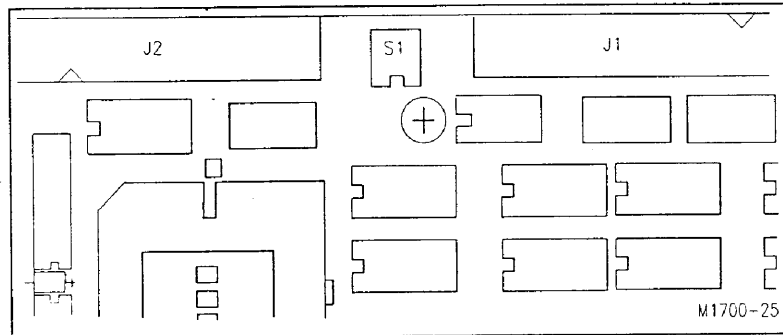

**Figure 7-17. Printhead Resistance Selector.**

8. Close the top cover assembly.
9. Replace the printhead cover.
10. Install the user interface assembly and the keyboard.
11. Run the Extended Self-test printer test described in Chapter 4.

---

## The Preview Logic Board

This section describes how to remove and replace the preview logic board. These procedures apply only to models equipped with the preview display option.

### Removing the Preview Logic Board

The procedure you will use depends on the serial number prefix of the unit you are servicing. Make sure you use the correct procedure for your particular PageWriter.

#### PageWriters with Serial Number Prefix 3208A or Later

If the PageWriter has a serial number prefix of 3208A or later, use this procedure to remove the preview logic board.

---

#### Caution



Use an electrostatic wrist band or other approved method for protection against electrostatic discharge when disconnecting and handling the preview logic board.

---

To remove the preview logic board:

#### Warning



---

**Perform the following four steps sequentially to eliminate the chance of exposure to hazardous voltages.**

1. Disconnect the AC power cord.
2. Verify that no disk is in the disk drive.
3. Turn the cardiograph **On**. (This allows the rectifier assembly capacitors to discharge more rapidly.)
4. Remove the battery as described earlier in this chapter.
5. Remove the top cover assembly as described previously in this chapter.

6. Remove the four screws that hold the preview logic board and shield to the chassis (see Figure 7-18).
7. Disconnect the preview logic board assembly from the system expansion connector on the CPU board assembly, and slide the logic board out.

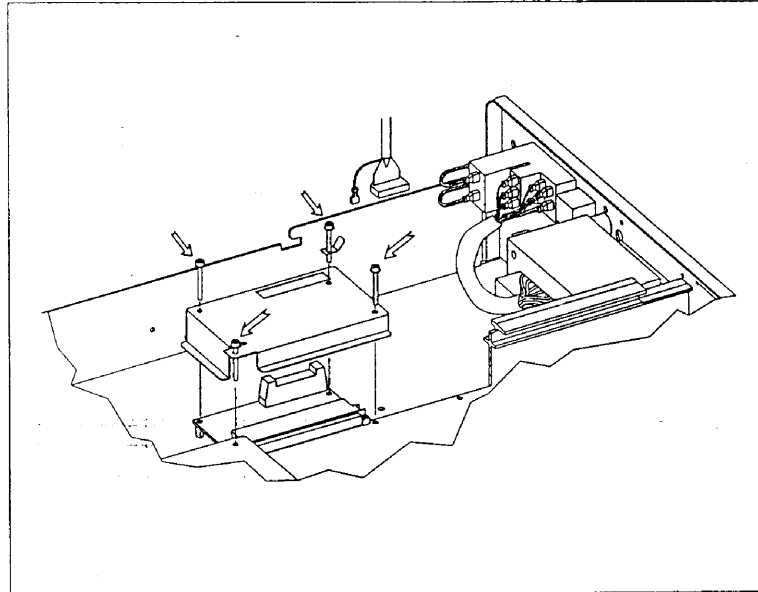

**Figure 7-18.**  
**Preview Logic Board Removal (Serial Number Prefix 3208A or Later).**

**PageWriters with Serial Number Prefix Prior to 3208A**

If the PageWriter has a serial number prefix prior to 3208A, use this procedure to remove the preview logic board.

**Caution**



---

Use an electrostatic wrist band or other approved method for protection against electrostatic discharge when disconnecting and handling the preview logic board.

---

To remove the preview logic board:

**Warning**



---

**Perform the following four steps sequentially to eliminate the chance of exposure to hazardous voltages and to avoid damage to the preview display.**

---

1. Disconnect the AC power cord.
2. Verify that no disk is in the disk drive.
3. Turn the cardiograph **On**. (This allows the rectifier assembly capacitors to discharge more rapidly.)
4. Remove the battery as described earlier in this chapter.
5. Remove the top cover assembly as described previously in this chapter.
6. Remove the screws that hold the preview logic board and shield assembly to the chassis bottom and rear (see Figure 7-19).

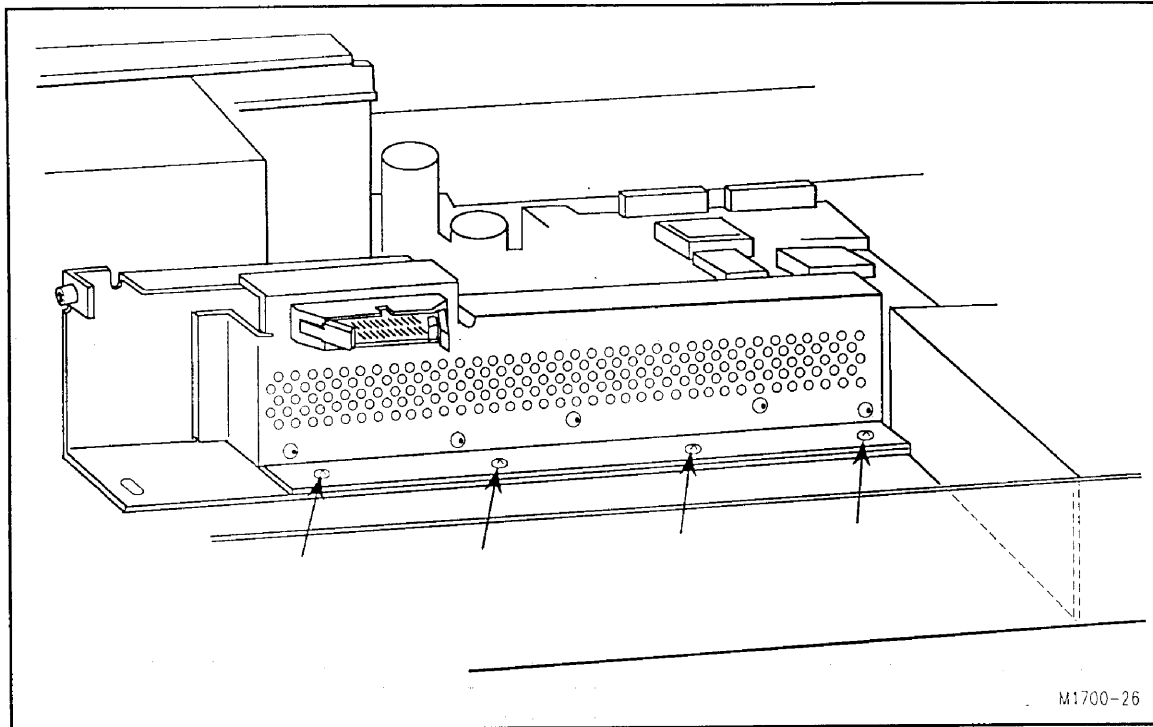

Figure 7-19. Preview Logic Board Assembly Screw Locations.

7. Disconnect the preview logic board assembly from the system expansion connector on the CPU board assembly, and slide the entire assembly out.
8. Remove the screws that hold the RFI shield and board to the frame. The shield and board can then be lifted off the frame.

#### Replacing the Preview Logic Board

To replace the logic board, reverse the appropriate removal procedure, or refer to the installation instructions included with the replacement part.

---

## The CPU Assembly

This section describes how to remove and replace the CPU assembly. This procedure applies to all units.

### Removing the CPU Assembly

To remove the CPU assembly:

Caution



---

Use an electrostatic wrist band or other approved method for protection against electrostatic discharge when disconnecting cables from and handling the CPU assembly.

---

Warning



---

**Perform the following four steps sequentially to eliminate the chance of exposure to hazardous voltages.**

---

1. Disconnect the AC power cord.
2. Verify that no disk is in the disk drive.
3. Turn the cardiograph **On**. (This allows the rectifier assembly capacitors to discharge more rapidly.)
4. Remove the battery as described earlier in this chapter.
5. Remove the top cover assembly as described previously in this chapter.
6. Disconnect the two rectifier cable spade lugs (J6 and J7) and the two disk drive cables (J14 and J15). (See Figure 7-20 for jumper locations.)
7. If the unit has a preview assembly, remove the preview logic board assembly as described previously in this chapter.
8. Remove the board mounting screws (shown in Figure 7-20). Also remove the jackposts that hold the serial and patient module connectors to the rear panel.
9. Lift off the RFI shield, then slide the board toward the front of the cardiograph and disconnect the spade lug at J8.
10. Lift the board out of the lower chassis.

Figure 7-20. Screw and Connector Locations on the CPU Assembly.

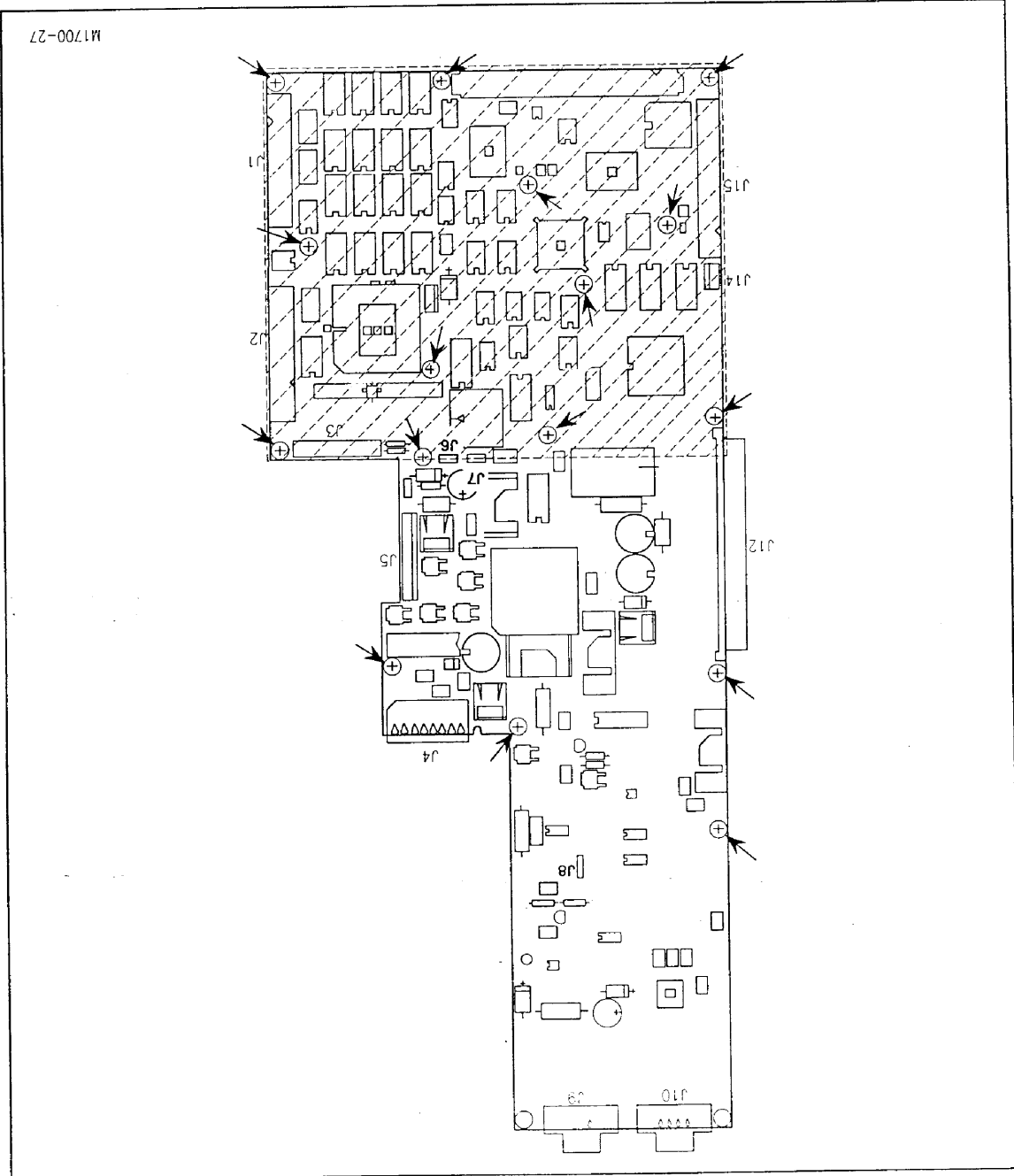

## Replacing the CPU Assembly

To replace the CPU assembly, reverse the removal procedure.

---

## The Disk Drive (M1700A and M1701A only)

This section describes how to remove and replace the disk drive.

To remove the disk drive:

### Caution



Use an electrostatic wrist band or other approved method for protection against electrostatic discharge when disconnecting cables from and handling the disk drive.

1. Remove the top cover assembly as described previously in this chapter.
2. Remove the two screws that attach the plastic vibration mounts to the chassis.
3. On units having a serial number prefix prior to 3208A, remove the 7/32-inch nut that attaches the ground strap to the chassis (see Figure 7-21).

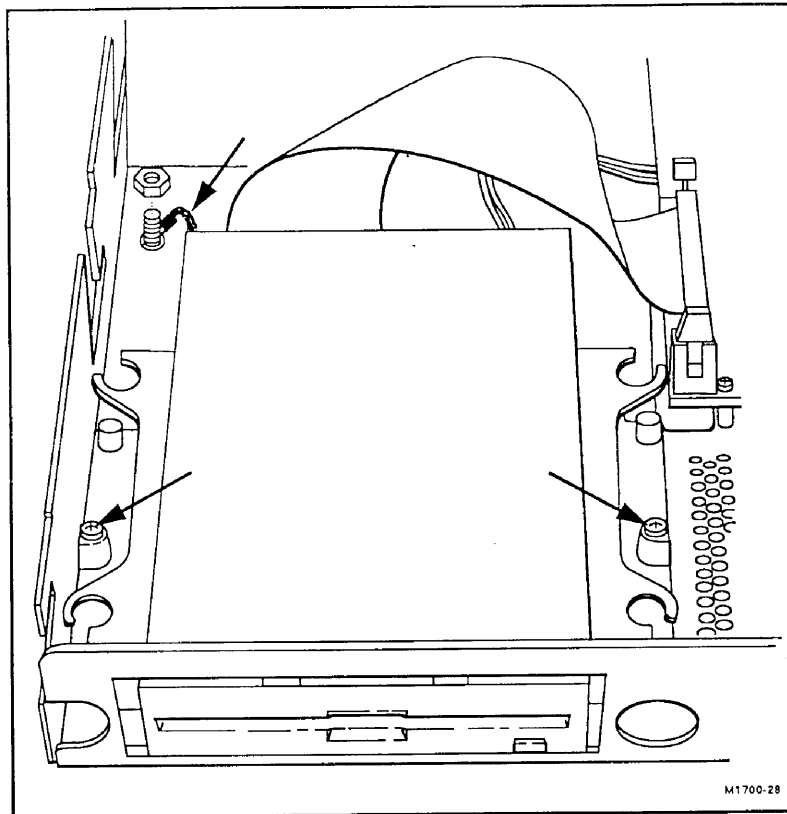

**Figure 7-21. Disk Drive Mounting Screws.**

4. Lift the disk drive enough to disconnect the data cable and power cable.
5. Remove the disk drive from the chassis.
6. Remove the screws that attach the vibration mounts to the disk drive and set the mounts aside for reuse.
7. Remove the screw that attaches the ground strap to the bottom of the disk drive; set the ground strap and screw aside for reuse.

### **Replacing the Disk Drive**

To replace the disk drive, reverse the removal procedure.

## Parts Lists

---

### Introduction

This chapter contains the parts lists for the cardiograph, printer, preview display, cart, and data communications package. The numbers on each figure or exploded view refer to the parts list on the facing page.

---

### Ordering Information

You can order any of the parts listed through your local Hewlett-Packard Sales/Service Office (listed at the back of this manual). In the United States and Canada you can call the Direct Customer Order Center toll-free at 1-800-227-8164.

In the United States, you can order medical supplies for the cardiograph by calling toll-free 1-800-225-0230.

---

### Calling for Assistance

Here are the numbers you can use to call Hewlett-Packard Service for technical assistance.

<b>United States of America</b>	<b>Eastern Region</b>	Tel: 1-800-245-4406
	<b>Western Region</b>	Tel: 1-800-428-0949
	<b>Southern Region</b>	Tel: 1-800-845-8374
	<b>Midwestern Region</b>	Tel: 1-800-323-2280
<b>Canada</b>	<b>Eastern Region</b>	Tel: 1-800-361-9790
	<b>Central and Western Region</b>	Tel: 1-800-268-1221

Refer any questions or comments regarding these instruments to the nearest HP Sales/Service Office, or to one of Hewlett-Packard's Service Dispatch Centers. Always identify the instrument by model number and serial number in all correspondence. Hewlett-Packard sales and service offices are listed at the end of this manual.

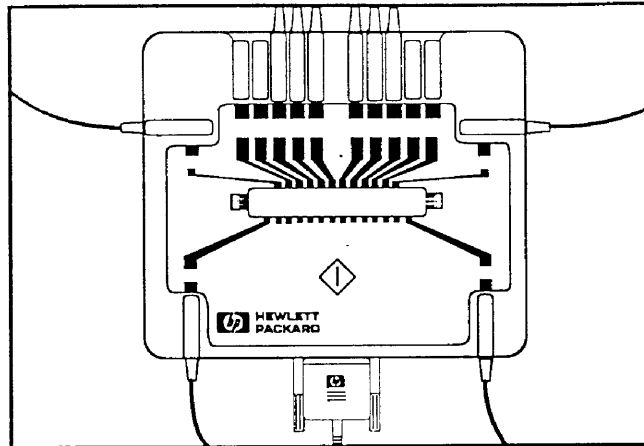



Figure 8-1. Patient Module Diagram.

---

**Note**  The M1702A patient module does not have a display or a start button.

---

**Note**  All references to AHA mean that the color code conforms to recommendations of the American Heart Association.

All references to IEC mean that the color code conforms to International Electrotechnical Commission Standards. Refer to Table 1-8 for your geographical location.

---

Table 8-1. Patient Module Parts List

Description	Part No.
Patient module, AHA (M1700A & M1701A)	M1700-69501
Patient module, IEC (M1700A & M1701A)	M1700-69502
Patient module, AHA (M1702A)	M1702-69501
Patient module, IEC (M1702A)	M1702-69502
SAECG patient module, AHA (M1700A)	M1700-69511
SAECG patient module, IEC (M1700A)	M1700-69512
Patient data cable, 2.5 M	M1719A
Patient data cable, 9.0 M	M1720A
Jack nuts (data cable inserts)	M1700-27903
Limb leadwire replacement kit, AHA	M1711A
Limb leadwire replacement kit, IEC	M1714A
Chest leadwire replacement kit (24 in/60 cm), AHA	M1712B
Chest leadwire replacement kit (24 in/60 cm), IEC	M1715B
Chest leadwire replacement kit (15 in/38 cm), AHA	M1712C
Chest leadwire replacement kit (15 in/38 cm), IEC	M1715C
Leadwire set, AHA, complete	M1713B
Leadwire set, IEC, complete	M1716B
Leadwire set, Peds/Frank (includes 2 Frank leads labels)	M1717B
Frank leads label	M1700-84513
Shorting plug	M1700-47602
Leadwire support kit	M1718A
Label for patient module, AHA (M1700A and M1701A)	M1700-84509
Label for patient module, IEC (M1700A and M1701A)	M1700-84592
Label for patient module, AHA (M1702A)	M1702-84509
Label for patient module, IEC (M1702A)	M1702-84510
Label for SAECG patient module, AHA (M1700A)	M1700-84589
Label for SAECG patient module, IEC (M1700A)	M1700-84590
Module end label	M1700-84521



**Note**

The battery door assembly does not include the door label. To get the label, order the label set for the language needed.

**Table 8-2.**  
**Main Assembly Parts List (Serial Number Prefix 3208A or Later)**

Ref. No.	Description	Part No.
1	CPU assembly, M1700A	M1700-60100
	Refurbished CPU assembly, M1700A	M1700-68100
	CPU assembly, M1701A	M1700-60104
	Refurbished CPU assembly, M1701A	M1700-68104
	CPU assembly, M1702A	M1700-60106
	Refurbished CPU assembly, M1702A	M1700-68106
2	User interface assembly	M1700-67120
2a	Main bezel assembly	M1700-67202
2b	Key PCB assembly (includes gasket)	M1700-47201
2c	Keyboard shield	M1700-84602
2d	LCD	M1700-67204
2e	Keyboard rubber gasket	M1700-47310
3	Key assembly, Dutch	M1700-64738
	Key assembly, English	M1700-64708
	Key assembly, French	M1700-64718
	Key assembly, German	M1700-64728
	Key assembly, Italian	M1700-64758
	Key assembly, Spanish	M1700-64748
	Key assembly, Swedish	M1700-64768
4	Battery assembly, lead-acid	M1721A
4a	Battery guide (left or right side)	M1700-47309
4b	Battery shield	M1700-47308
5	Battery door assembly	M1700-67108
6	Cover, right side (printhead)	M1700-47204
7	Left side (not shown)	M1700-47205
8	Cover, top rear (M1700A w/o preview, M1701A, M1702A)	M1700-47206
	Cover, top rear (M1700A w/ preview)	M1700-47225
9	Cover, front (M1700A and M1701A)	M1700-47207
	Cover, front (M1702A)	M1702-47207
10	Side, right lower	M1700-47217
11	Side, left lower	M1700-47229

**Table 8-2.  
Main Assembly Parts List (Serial Number Prefix 3208A or  
Later) (continued)**

Ref. No.	Description	Part No.
12	Jack nut	0380-2087
13	Diode array cable assembly	M1700-61608
14	Disk drive (M1700A and M1701A)	0950-2075
15	Disk logic cable (M1700A and M1701A)	M1700-61609
16	Disk power cable (M1700A and M1701A)	M1700-61610
17	Keyboard cable	M1700-61614
19	Fuse, battery, 8 A time delay	2110-0827
20a	Line module	M1700-89504
20b	Voltage selector	9135-0248
20c	Fuse holder (2.5 A, 100/120 V)	2110-0686
	Fuse holder (1.6 A, 220/240 V)	2110-0687
	Line module fuse (2.5 A, 100/120 V)	2110-0015
	Line module fuse (1.6 A, 220/240 V)	2110-0773
21	AC switch	3101-0402
23	ROM (M1700A and M1701A) (not shown)	M1700-17950
	ROM (M1702A) (not shown)	M1702-17950
	ROM, delete analysis/preview (option D06) (not shown)	M1700-17951
	Software set, version A.01.01 (M1700A)	M1700-17700
	Software set, version A.01.01 (M1701A)	M1701-17700
	Software set, SAECG, version A.01.00 (M1754A)	M1754-17700
	Software set, version A.02.00	M1700-17710
	Software set, version A.03.00 (M1755A)	M1700-17720
	Software set, VCG, version A.01.00 (M1790A)	M1790-17700
	Software set, delete analysis/preview (option D06)	M1700-17711
	3.5in, high density replacement disks (box of 10)	M1700-89004
	Power cord (UK)	8120-1351
	Power cord (Australia)	8120-4475
	Power cord (Europe)	8120-1692
	Power cord (US)	8120-5213
	Power cord (Denmark)	8120-2956
	Power cord (Switzerland)	8120-2104
	Power cord (South Africa)	8120-4211
24	AC transformer assembly	M1700-67114
25	Chassis, lower (sheet metal only)	M1700-07323
26	Chassis, upper (sheet metal only)	M1700-07324

**Table 8-2.**  
**Main Assembly Parts List (Serial Number Prefix 3208A or  
 Later) (continued)**

Ref. No.	Description	Part No.
	Label, name set (M1700A, M1701A and M1702A)	M1700-84574
	Label set, Dutch (M1700A and M1701A)	M1700-84638
	Label set, English (M1700A and M1701A)	M1700-84608
	Label set, Finnish (M1700A and M1701A)	M1700-84688
	Label set, French (M1700A and M1701A)	M1700-84618
	Label set, German (M1700A and M1701A)	M1700-84628
	Label set, Italian (M1700A and M1701A)	M1700-84658
	Label set, Norwegian (M1700A and M1701A)	M1700-84678
	Label set, Spanish (M1700A and M1701A)	M1700-84648
	Label set, Swedish (M1700A and M1701A)	M1700-84668
	Label set, Dutch (M1702A)	M1702-84638
	Label set, English (M1702A)	M1702-84608
	Label set, Finnish (M1702A)	M1702-84688
	Label set, French (M1702A)	M1702-84618
	Label set, German (M1702A)	M1702-84628
	Label set, Italian (M1702A)	M1702-84658
	Label set, Norwegian (M1702A)	M1702-84678
	Label set, Swedish (M1702A)	M1702-84668
	Label set, Spanish (M1702A)	M1702-84648
	Keyboard label set, Dutch	M1700-84738
	Keyboard label set, English	M1700-84708
	Keyboard label set, Finnish	M1700-84788
	Keyboard label set, French	M1700-84718
	Keyboard label set, German	M1700-84728
	Keyboard label set, Italian	M1700-84758
	Keyboard label set, Norwegian	M1700-84778
	Keyboard label set, Spanish	M1700-84748
	Keyboard label set, Swedish	M1700-84768
29	Preview logic PCA (M1700A w/ preview only)	M1700-69505
30	Preview standoff	M1700-27408
31	Preview logic shield	M1700-07329
32	Terminal tab	0360-1613
33	CPU shield	M1700-07320
34	Foot	M1700-47319
35	Cup	M1700-47320
36	Retainer	M1700-47321
	Preview logic replacement cable assembly	M1700-61620
	Foot repair kit	M1700-69504

**Table 8-2.**  
**Main Assembly Parts List (Serial Number Prefix 3208A or**  
**Later) (continued)**

Ref. No.	Description	Part No.
	Replacement case assembly (complete outer shell, sheet metal and plastic)	M1700-69503
	AC switch	3101-0402
	Power module	9135-0457
	Lower chassis	M1700-07323
	Top (sheet metal)	M1700-07324
	Cover	M1700-47206
	Cover-disp	M1700-47225
	Front	M1700-47207
	Front	M1702-47207
	Lower right side	M1700-47217
	Lower left side	M1700-47229
	Disk support	M1700-47303
	Battery shield	M1700-47308
	Battery guide	M1700-47309
	Foot	M1700-47319
	Cup	M1700-47320
	Retainer	M1700-47321

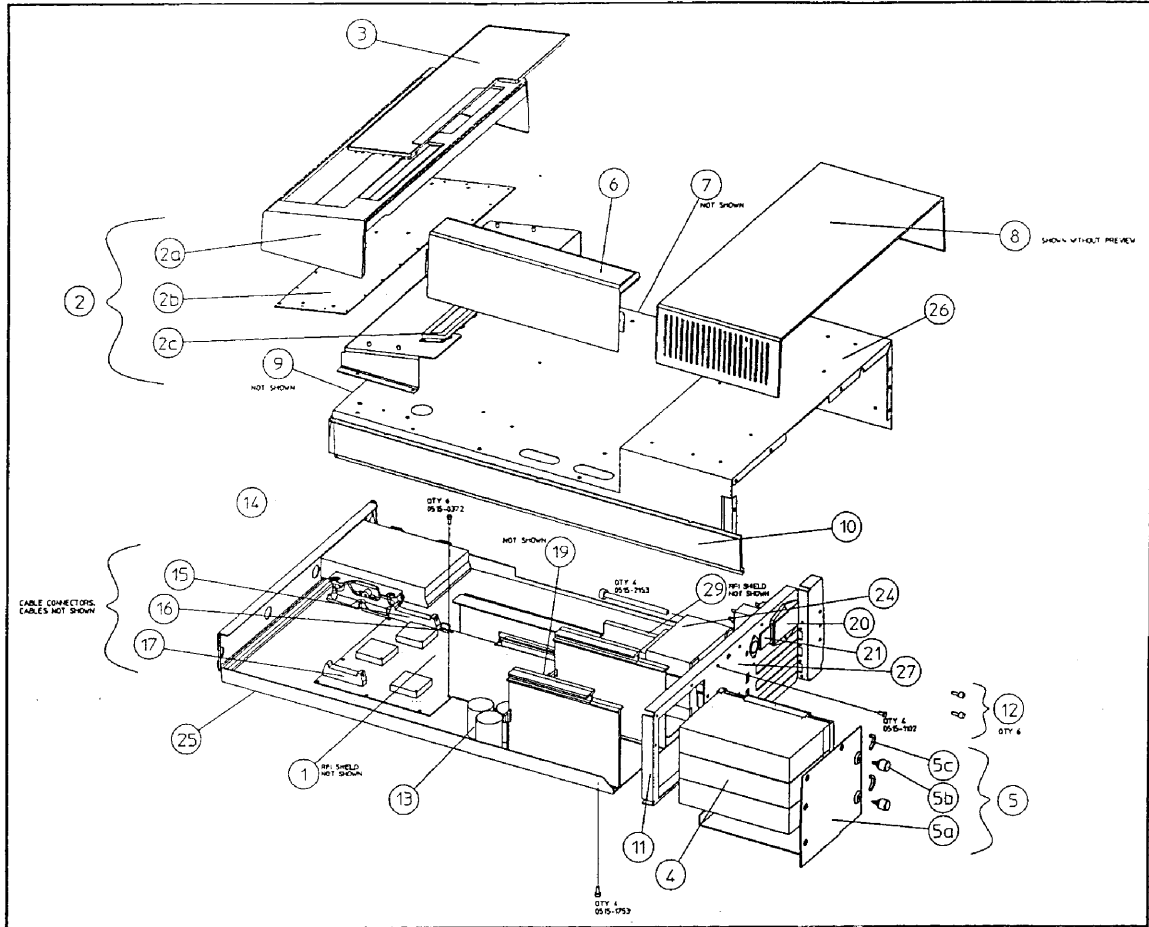

Figure 8-3. Main Assembly Exploded Diagram (Serial Number Prefix Prior to 3208A).

**Note**



The battery door assembly does not include the door label. To get the label, order the label set for the language needed.

**Table 8-3.**  
**Main Assembly Parts List (Serial Number Prefix Prior to**  
**3208A)**

Ref. No.	Description	Part No.
1	CPU assembly, M1700A	M1700-60100
	Refurbished CPU assembly, M1700A	M1700-68100
	CPU assembly, M1701A	M1700-60104
	Refurbished CPU assembly, M1701A	M1700-68104
	CPU assembly, M1702A	M1700-60106
	Refurbished CPU assembly, M1702A	M1700-68106
2	User interface assembly	M1700-67113
2a	Main bezel assembly	M1700-67202
2b	Key PCB assembly	M1700-47201
	Keyboard rubber gasket	M1700-47310
2c	LCD	M1700-67204
3	Key assembly, Dutch	M1700-64738
	Key assembly, English	M1700-64708
	Key assembly, French	M1700-64718
	Key assembly, German	M1700-64728
	Key assembly, Italian	M1700-64758
	Key assembly, Spanish	M1700-64748
	Key assembly, Swedish	M1700-64768
4	Battery assembly, lead-acid	M1721A
4a	Battery guide (left or right side)	M1700-47309
	Battery shield (left or right side)	M1700-47308
5	Battery door assembly	M1700-67108
6	Cover, right side (printhead)	M1700-47204
7	Left side (not shown)	M1700-47205
8	Cover, top rear (M1700A w/o preview, M1701A, M1702A)	M1700-47206
	Cover, top rear (M1700A w/ preview)	M1700-47225
9	Cover, front (M1700A and M1701A) (not shown)	M1700-47207
	Cover, front (M1702A)	M1702-47207
10	Side, right lower	M1700-47217
	Side, left lower	M1700-47229
11	(See item 27)	
12	Jack nut	M1700-27903
13	Diode array cable assembly	M1700-61608
14	Disk drive (M1700A and M1701A)	0950-2075

**Table 8-3.**  
**Main Assembly Parts List (Serial Number Prefix Prior to**  
**3208A) (continued)**

Ref. No.	Description	Part No.
15	Disk logic cable (M1700A and M1701A)	M1700-61609
16	Disk power cable (M1700A and M1701A)	M1700-61610
17	Keyboard cable	M1700-61614
19	Fuse, battery, 8 A time delay	2110-0827
20	Line module	M1700-89504
	Fuse holder (2.5 A, 100/120 V)	2110-0686
	Fuse holder (1.5 A, 220/240 V)	2110-0687
	Line module fuse (2.5 A, 100/120 V)	2110-0015
	Line module fuse (1.6 A, 220/240 V)	2110-0773
21	AC switch	3101-0402
23	ROM (M1700A and M1701A) (not shown)	M1700-17950
	ROM (M1702A) (not shown)	M1702-17950
	Software set, version A0.01.01 (M1700A)	M1700-17700
	Software set, version A0.01.01 (M1701A)	M1701-17700
	Software set, SAECG, version A.01.00 (M1754A)	M1754-17700
	Software set, version A.02.00	M1700-17710
	Software set, version A.03.00 (M1755A)	M1700-17720
	Software set, version, VCG, A.01.00 (M1790A)	M1790-17700
	3.5in, high density replacement disks (box of 10)	M1700-89004
	Power cord (UK)	8120-1351
	Power cord (Australia)	8120-4475
	Power cord (Europe)	8120-5368
	Power cord (US)	8120-5213
	Power cord (Denmark)	8120-2956
	Power cord (Switzerland)	8120-2104
	Power cord (South Africa)	8120-4211
24	AC transformer assembly	M1700-67114
25	Chassis, lower (sheet metal only)	M1700-07313
26	Chassis, upper	M1700-67112
	Label, name set (M1700A, M1701A and M1702A)	M1700-84574
	Label set, Dutch (M1700A and M1701A)	M1700-84638
	Label set, English (M1700A and M1701A)	M1700-84608
	Label set, Finnish (M1700A and M1701A)	M1700-84688
	Label set, French (M1700A and M1701A)	M1700-84618
	Label set, German (M1700A and M1701A)	M1700-84628
	Label set, Italian (M1700A and M1701A)	M1700-84658
	Label set, Norwegian (M1700A and M1701A)	M1700-84678
	Label set, Spanish (M1700A and M1701A)	M1700-84648
	Label set, Swedish (M1700A and M1701A)	M1700-84668

Table 8-3.  
Main Assembly Parts List (Serial Number Prefix Prior to  
3208A) (continued)

Ref. No.	Description	Part No.
	Label set, Dutch (M1702A)	M1702-84638
	Label set, English (M1702A)	M1702-84608
	Label set, Finnish (M1702A)	M1702-84688
	Label set, French (M1702A)	M1702-84618
	Label set, German (M1702A)	M1702-84628
	Label set, Italian (M1702A)	M1702-84658
	Label set, Norwegian (M1702A)	M1702-84678
	Label set, Spanish (M1702A)	M1702-84648
	Label set, Swedish (M1702A)	M1702-84668
	Keyboard label set, Dutch	M1700-84738
	Keyboard label set, English	M1700-84708
	Keyboard label set, Finnish	M1700-84788
	Keyboard label set, French	M1700-84718
	Keyboard label set, German	M1700-84728
	Keyboard label set, Italian	M1700-84758
	Keyboard label set, Norwegian	M1700-84778
	Keyboard label set, Spanish	M1700-84748
	Keyboard label set, Swedish	M1700-84768
27	Power panel assembly (includes transformer)	M1700-67115
29	Preview logic replacement assembly (M1700A w/ preview only)	M1700-69505
	Preview logic replacement cable assembly	M1700-61620
	Foot repair kit	M1700-69504

Table 8-3.  
Main Assembly Parts List (Serial Number Prefix Prior to  
3208A) (continued)

Ref. No.	Description	Part No.
	Replacement case assembly (complete outer shell, sheet metal and plastic)	M1700-69503
	AC switch	3101-0402
	Power module	9135-0457
	Lower chassis	M1700-07323
	Top (sheet metal)	M1700-07324
	Cover	M1700-47206
	Cover-disp	M1700-47225
	Front	M1700-47207
	Front	M1702-47207
	Lower right side	M1700-47217
	Lower left side	M1700-47229
	Disk support	M1700-47303
	Battery shield	M1700-47308
	Battery guide	M1700-47309
	Foot	M1700-47319
	Cup	M1700-47320
	Retainer	M1700-47321

Table 8-4. Fastener List

Use Location	Description	Part No.
Transformer assembly to rear panel	M3-8 flathead screw (T10)	0515-1102
CPU assembly and preview logic assembly to chassis, top case to rear panel, disk drive to chassis	M3-8 screw w/ lockwasher (T10)	0515-0372
CPU shield through CPU assembly to chassis	M3-25 (T10)	0515-0446
All plastic parts to chassis, keyboard PCB to front bezel, LCD to front bezel	4-24 × 0.250 self-tapping screw (T10)	0624-0730
Printer gear assembly to chassis, feet to chassis	M3-8 screw (T10)	0515-1753
Preview clutch mounting	M4-20 screw (T15)	0515-0686
User interface to chassis	M3-10 flathead (T10)	0515-1103
Preview logic shield to chassis (serial number prefixes prior to 3208A only)	M3-12 screw (T10)	0515-0664

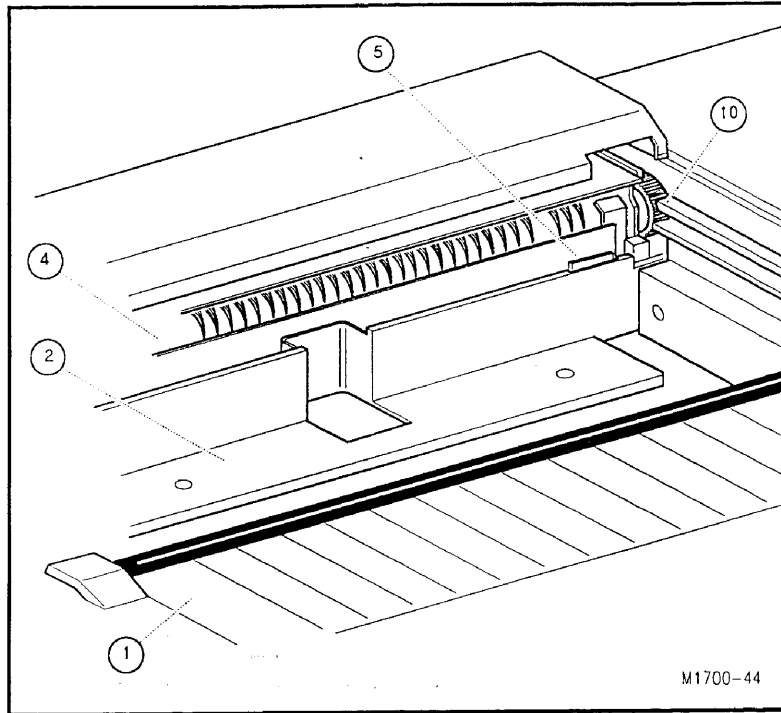

Figure 8-4. Printer Assembly Diagram.

**Note**



The printer door assembly does not include the door label. To get the label, order the label set for the language needed.

Table 8-5. Printer Parts List

Ref. No.	Description	Part No.
1	Printer door, English	M1700-67106
	Printer door, Metric	M1700-67107
	Printer door snap	M1700-47104
2	Printer well assembly	M1700-47220
	Paper spacer, metric	M1700-47316
	Leaf spring	M1700-27406
4	Printhead assembly	M1700-67402
	Printhead	9060-0793
	Printer logic cable	M1700-61611
	Printer power cable	M1700-61612
5	Printer sensor assembly	M1700-61628
	Printer sensor lens	M1700-43301
10	Gear/motor assembly	M1700-67400
	Printer motor cable	M1700-61613

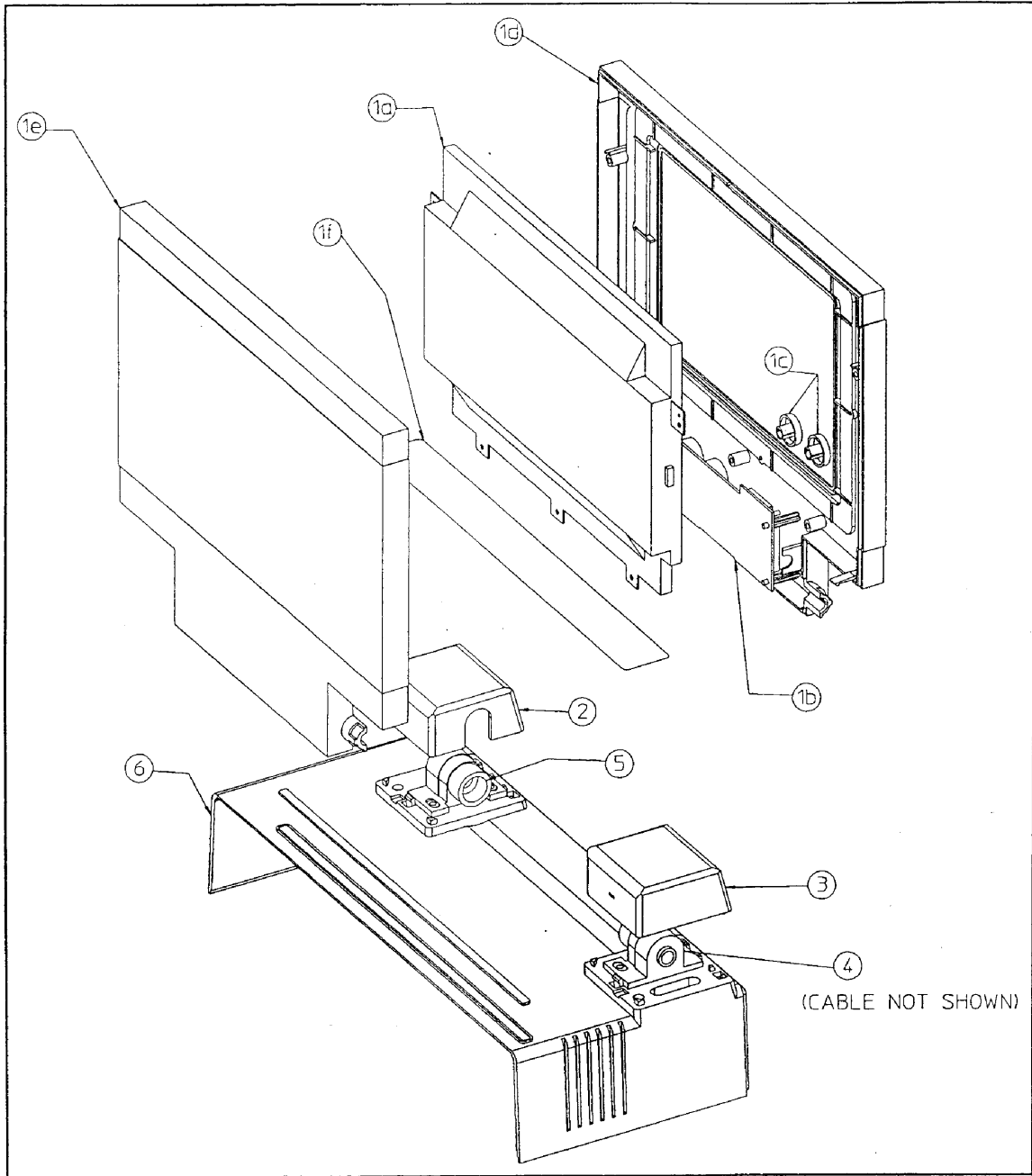

Figure 8-5. Preview Display Assembly Diagram.

**Table 8-6. Preview Display Assembly Parts List**

Ref. No.	Description	Part No.
1	Replacement preview assembly, complete	M1700-67104
1a	Preview LCD	M1700-27904
1b	Preview power supply	M1700-60102
1c	Knob	M1700-47501
1d	Preview bezel assembly	M1700-67203
1e	Preview back cover	M1700-47222
1f	Preview ESD shield (serial number prefixes prior to 3208A only)	M1700-84594
2	Clutch cover, right	M1700-47101
3	Clutch cover, left	M1700-47102
4	Display cable (includes left preview clutch)	M1700-67120
5	Preview clutch	M1700-67901
6	Cover, top rear	M1700-47225

**Note**



PageWriters having a serial number prefix of 3208A or later have a new design that allows easier component-level repair of the preview screen assembly.

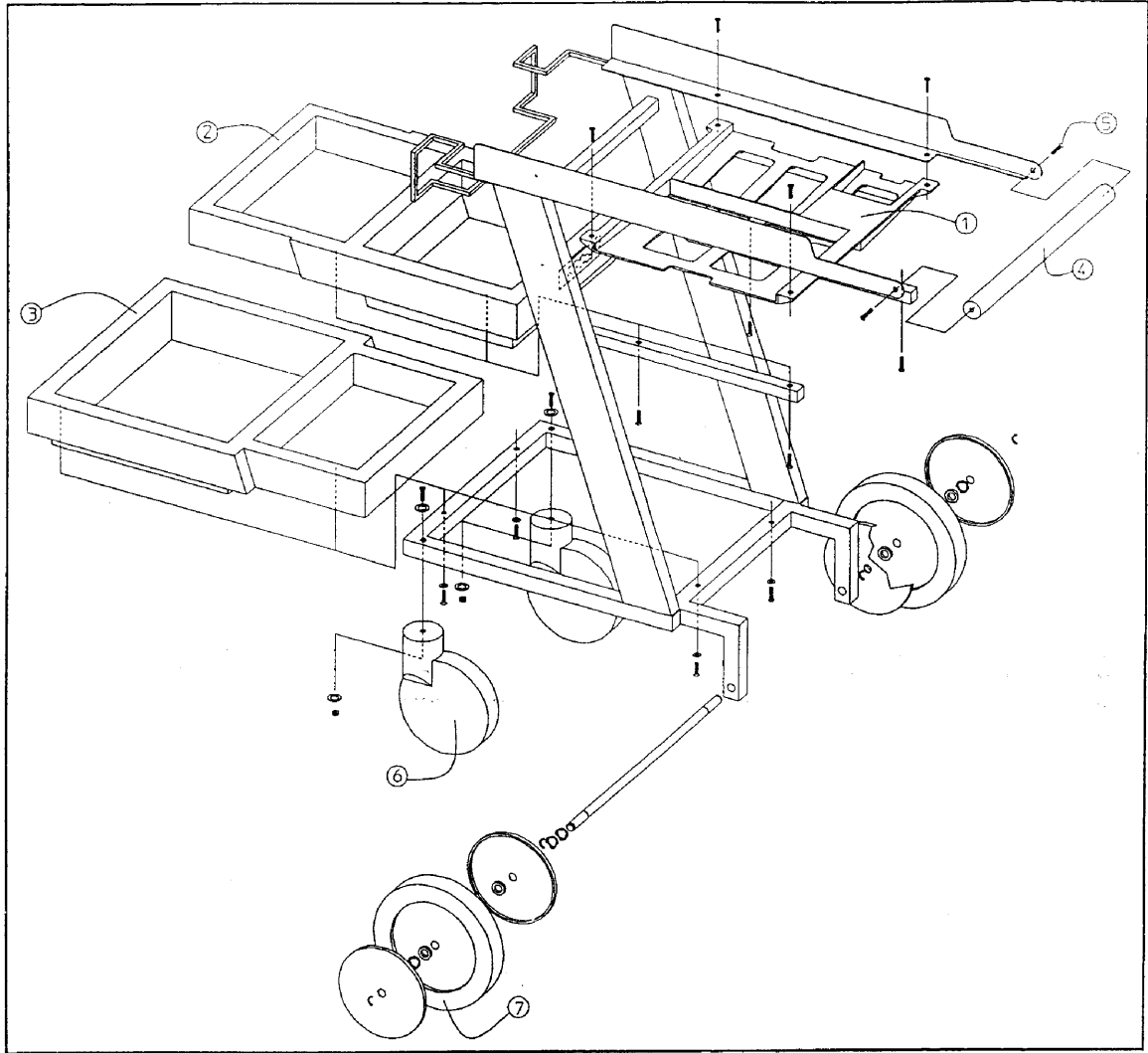

Figure 8-6. Cart Exploded Diagram.

Table 8-7. Cart Parts List

Ref. No.	Description	Part No.
	Cart assembly, M1705A	
1	Paper tray	M1705-47305
2	Upper tray	M1705-47301
3	Lower tray	M1705-47302
4	Handle	M1705-67300
5	Handle bolt	2940-0281
6	Front caster	1492-0150
7	Rear wheel (removable axle)	1492-0151
	Rear wheel (painted axle)	1492-0129
	Touch-Up Paint "French Grey"	6010-1147
	Paper management tray (not shown)	M1705-89500

Table 8-8. Cart Fastener List

Description	Part No.
Cardiograph securing screw, captive	M1700-27907
Ring, retaining; 2 per rear wheel	0510-1195
Lock nut; secures front caster	0590-1037
Screw, tpg. 6-19; secures upper and lower trays	0624-0654
Screw, tpg. 6-19; secures paper tray	0624-0400
Flat washers; 2 per front caster	2190-0457
Screw, machine 8-32; secures front of lower tray	2510-0270
Hex-head captive screw 3/8 - 16 x 2; secures front caster	2940-0201
Wave washer; 2 per rear wheel (removable axle)	3050-1296
Spacer, wheel; 2 per rear wheel (removable axle)	M1705-27405
Nylon washer for lower tray screws (removable axle)	3050-0769
Metal washer for rear, lower tray screws	2190-0758
Retainer cap (painted axle)	0590-1977
E ring (removable axle)	0510-1195
Flat washer (painted axle)	3050-1401

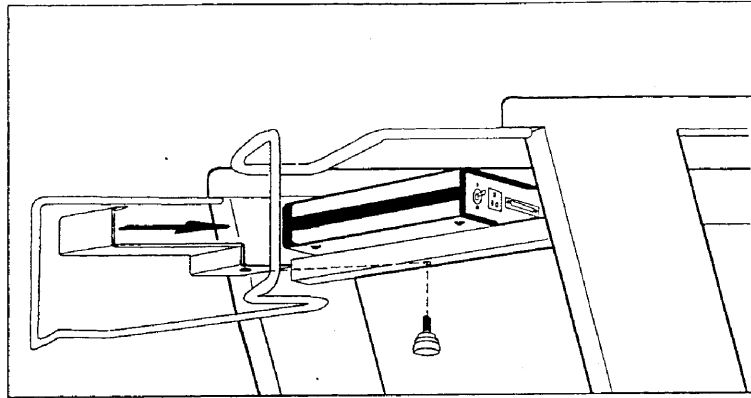
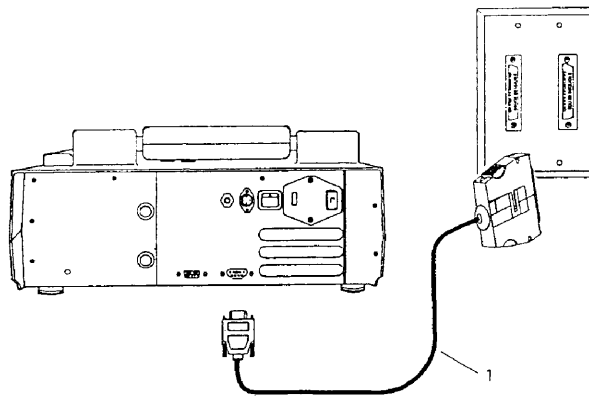

Figure 8-7. Data Communications Package Diagram.

Table 8-9. Data Communications Package Parts List

Description	Part No.
Bracket for Hayes® modem	M1706-07102
Screw, 10-32, knurled for Hayes®	0370-3219
Power cable for Hayes® modem	M1706-61619
Standard data cable for Hayes® modem	M1706-61630
Hayes® modem (Canada)	M1706-89502
Hayes® modem (France)	M1706-89503
Hayes® modem (Italy)	M1706-89506
Hayes® modem (Netherlands)	M1706-89504
Hayes® modem (United Kingdom)	M1706-89505
Hayes® modem (United States)	M1706-89501
Data cable, direct	24542M
Data cable, direct to LaserJet	24542G
Quick Connect cable, fax modem	M1756-61601
WorkStation adapter	92224F
XL Quick Connect	M1706-61636
"Quick Connect Hayes®"	M1706-61637



**Figure 8-8. Connections for Direct-Connect Transmission**

**Table 8-10. Direct Connect Cable Parts List**

Ref No.	Description	Part No.
1	Direct Connect Cable	24542M or M1706-61636

**Note**



M1706-61636 cable has locking clips to securely connect to the faceplate. The 24542M cable does not.

The M1706-61636 cable measures 5 feet (1.52 meters); the 24542M measures 9.9 feet (3 meters).

The 24542M, M1706-61630, and M1706-61636 cables are electrically equivalent and can be interchanged for troubleshooting.

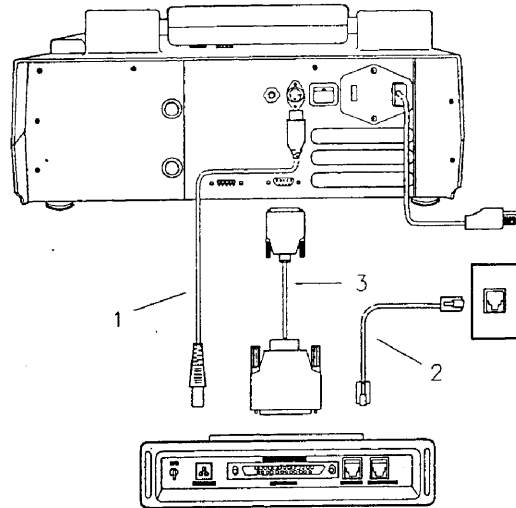
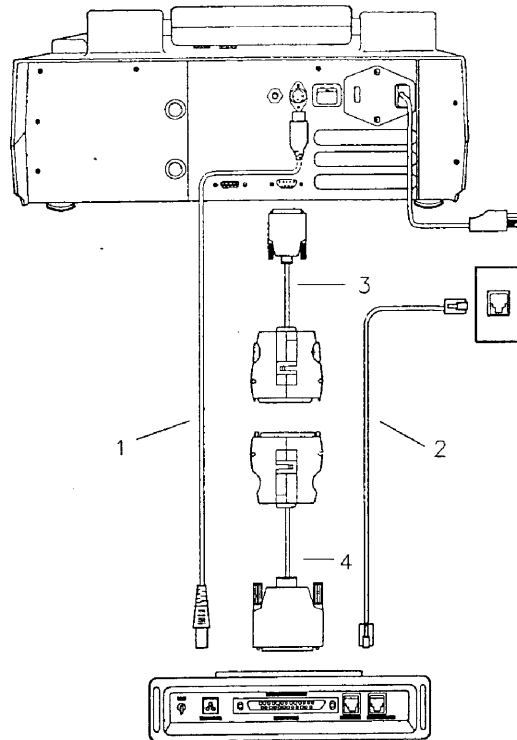

Figure 8-9. Cabling for Hayes Modem Transmission Only

Table 8-11. Hayes Modem Cable Parts List

Ref No.	Description	Part No.
1	Hayes Modem Power Cable	M1706-61619
2	Phone Line Cables	
	US	8120-3395
	French	M1706-61632
	US	M1706-61633
	US	M1706-61634
	US	M1706-61635
3	Hayes Data Cable	M1706-61630



**Figure 8-10.**  
**Cabling for Hayes Modem and Direct Connect (Quick Connect)**  
**Transmission**

**Table 8-12.**  
**Hayes Modem and Direct Connect Cables Parts List**

Ref No.	Description	Part No.
1	Hayes Modem Power Cable	M1706-61619
2	Phone Line Cable	See Table 8-11
3	Quick Connect Cable	M1706-61636
4	Hayes Quick Connect Cable	M1706-61637

**Note**



The M1706-61636 cable functions as a direct connect cable when separated from the M1706-61637.



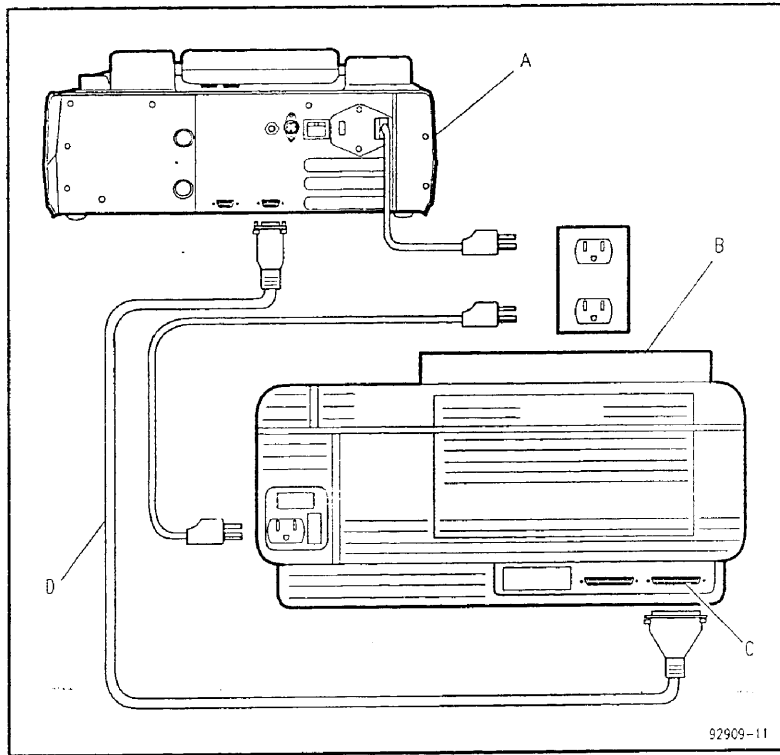

Figure 8-11. Cabling for LaserJet Printing

Table 8-13. LaserJet Cable Parts List

Ref No.	Description	Part No.
1	LaserJet Data Cable	24542G

## Connector Pin Assignments

---

The tables in this appendix list the pin assignments for each connector on the CPU assembly and the preview display boards. Following each table is a dictionary of the signal names listed in the table. Signal names that begin with a lowercase n are active low signals. NC means no connection to a pin. Refer to Figure 5-2 and Figure 5-12 to see how the system interconnects.

---

### CPU Assembly Connectors

Refer to Figure 7-20 for the CPU assembly connector locations.

#### Note



The system's 5 V power supply is divided into several circuits, each of which is passively filtered for EMI. Therefore, the +5V signal shown in the pin assignment tables does not always represent the same filtered 5 volt circuit.

---

**Table A-1.**  
**Keyboard and Keyboard Display (LCD) Connector J1**

Pin	Signal	Pin	Signal
1	GROUND	14	GROUND
2	+5V	15	LCDRS
3	GROUND	16	VLCD
4	nONKEY	17	LCDE
5	GROUND	18	LCDRW
6	ACONLED	19	LCDDATA(1)
7	GROUND	20	LCDDATA(0)
8	KRX	21	LCDDATA(3)
9	KBD RESET	22	LCDDATA(2)
10	KTX	23	LCDDATA(5)
11	GROUND	24	LCDDATA(4)
12	GROUND	25	LCDDATA(7)
13	+5V	26	LCDDATA(6)

**Note**



The connector listed in this table is shared by the keyboard and the keyboard display. Pins 1-11 serve the keyboard, while pins 12-26 serve the keyboard display. All of the signal lines (except ground) are filtered before they pass through this connector.

Signal	Definition
ACONLED	AC on LED. Drives the AC indicator LED on the keyboard.
KBD RESET	Keyboard controller reset.
KRX	Keyboard receive—data from the CPU assembly.
KTX	Keyboard transmit—data to the CPU assembly.
LCDDATA	Eight data bits for keyboard LCD.
LCDE	LCD Enable—active high.
LCDRS	Control that identifies data as display or instruction.
LCDRW	LCD Read/Write control—read high, write low.
nONKEY	Signal generated by <b>On-Standby</b> key—active low. Initiates the DRAM gate array during power-up.
VLCD	Contrast voltage to the keyboard display (LCD).

**Table A-2. Printhead Logic Connector J2**

Pin	Signal	Pin	Signal
1	+5V	14	VTHERM
2	+5V	15	nPSTB
3	PDOUT	16	NC
4	GROUND	17	nPSTB
5	nPSTB	18	NC
6	GROUND	19	nPSTB
7	nPSTB	20	GROUND
8	NC	21	nLATCH
9	nPSTB	22	GROUND
10	NC	23	PRCLK
11	nPSTB	24	GROUND
12	5VREF	25	NC
13	nPSTB	26	GROUND

Signal	Definition
5VREF	Reference voltage from the pulse width monitor (PWM) in the +5 volt supply. Valid when the cardiograph is <b>On</b> .
nLATCH	Printhead latch—latches a line of print data.
nPSTB	Printhead strobe—enables the dot drivers.
PDOUT	Print data output to printhead.
PRCLK	Printhead clock. Clocks serial data into printhead at 4 MHz.
VTHERM	Voltage from printhead thermistor—indicates printhead temperature.

**Table A-3. Printer Motor and Sensor Connector J3**

Pin	Signal	Pin	Signal
1	VPRINT	8	P3
2	GROUND	9	GROUND
3	P4	10	DETECTOR
4	VMOTOR	11	GROUND
5	P2	12	GROUND
6	P1	13	EMITTER
7	VMOTOR	14	DOOR

Signal	Definition
DETECTOR	Paper sensor detector.
DOOR	Indicates the state of the printer compartment door. High when door closed.
EMITTER	Paper sensor emitter.
P1-P4	Drive signals for the printer's four-phase stepper motor.
VPRINT	Switched battery voltage to the printhead. Enabled with +5READY signal.
VMOTOR	Power to the motor. Enabled with +5READY signal.

**Table A-4. Battery Connector J4**

Pin	Signal
1	THERM-
2	THERM+
3	GROUND
4	NOBATT
5	VBAT-
6	VBAT-
7	VBAT+
8	VBAT+

Signal	Definition
NOBATT	Indicates the battery's presence. Low while battery is installed.
THERM-	Connects to the thermistor in the battery assembly.
THERM+	Connects to the thermistor in the battery assembly.
VBAT-	Battery negative terminal—connected to ground through a resistor.
VBAT+	Battery positive terminal—connected to VBAT voltage line through a fuse.

**Table A-5. Printhead Power Connector J5**

Pin	Signal	Pin	Signal
1	VPRINT	8	GROUND
2	VPRINT	9	GROUND
3	VPRINT	10	GROUND
4	VPRINT	11	GROUND
5	VPRINT	12	GROUND
6	VPRINT	13	GROUND
7	VPRINT	14	GROUND

Signal	Definition
VPRINT	Power to the printhead. Enabled with +5READY signal.

Table A-6. Patient Module Connector J9

Pin	Signal
1	GROUND
2	RFCLK
3	GROUND
4	RFEDATA
5	VFE
6	QRFEDATA
7	GROUND
8	GROUND
9	GROUND
CASE	GROUND

Signal	Definition
QRFEDATA	Output signal to the patient module.
RFCLK	Clock input from the patient module.
RFEDATA	Data input from the patient module.
VFE	Regulated voltage for patient module.

Table A-7. RS-232 Connector J10

Pin	Signal
1	DCD
2	RXD
3	TXD
4	DTR
5	GROUND
6	DSR
7	RTS
8	CTS
9	RI
CASE	GROUND

Signal	Definition
DCD	Data clear device. RS-232 handshaking signal.
nCTS	Clear to send. RS-232 signal.
nDTR	UART output.
RI	Ring in. RS232 signal.
RTS	Ready to send. RS232 signal.
RXD	Received data. UART input.
TXD	Transmit data. UART output.

Table A-8. System Expansion Connector J12

Pin	Row A	Row B	Row C	Pin	Row A	Row B	Row C
1	+5V	GROUND	MIO <sub>n</sub>	17	nRDY	BT0	GROUND
2	A(17)	A(9)	A(1)	18	GROUND	GROUND	NC
3	A(18)	A(10)	A(2)	19	nLOCK	IBIT2	OBIT1
4	A(19)	A(11)	A(3)	20	INTR	INT7	nADS
5	A(20)	A(12)	A(4)	21	GROUND	GROUND	GROUND
6	A(21)	A(13)	A(5)	22	ADS	D(8)	D(0)
7	A(22)	A(14)	A(6)	23	DC <sub>n</sub>	D(9)	D(1)
8	A(23)	A(15)	A(7)	24	LCDRS	D(10)	D(2)
9	GROUND	A(16)	A(8)	25	nRD	D(11)	D(3)
10	TURBO	GROUND	GROUND	26	nWEL	D(12)	D(4)
11	VBACK7	PCLK	+5V	27	nWEH	D(13)	D(5)
12	nPVEND	+5V	nRESETP	28	+5V	D(14)	D(6)
13	IBIT0	GROUND	GROUND	29	LCDRW	D(15)	D(7)
14	GROUND	DIR	+5READY	30	VIN	VIN	LCDON
15	HLDA	VBACK7	+5V	31	GROUND	nBHE	nBLE
16	HOLD	BT1	nWAIT	32	NC	WR <sub>n</sub>	GROUND

Signal	Definition
+5READY	Goes high when cardiograph +5 volt supply is within regulation. Goes low when +5 volt supply is off or out of regulation.
A(1)–A(23)	CPU address bus.
ADS	CPU address strobe—active high.
BT0, BT1	Bus cycle state bits. Indicates current bus cycle.
D(0)–D(15)	CPU data bus.
DC <sub>n</sub>	CPU output. 1 = data, 0 = control cycle.
HLDA	Hold acknowledge from CPU.
HOLD	Hold request from CPU.
IBIT0, IBIT2	General purpose input bits.
INT7	Expansion interrupt.
INTR	Interrupt line to the CPU.
LCDON	Enables preview LCD.
LCDRS	Control that identifies data as display or instruction.
LCDRW	LCD read/write control—1 = read, 0 = write.
MIO <sub>n</sub>	CPU memory/IO control signal. 1 = memory cycle, 0 = I/O cycle.

nADS	CPU address strobe—active low.
nBHE	CPU byte high enable strobe.
nBLE	CPU byte low enable strobe.
nLOCK	CPU lock—active low.
nPVEND	Preview enable. Asserted low during select of preview I/O or memory.
nRD	Read enable signal for EPROM.
nRDY	Ready. Derived from wait state generator. Terminates current bus cycle.
nWAIT	Wait states are forced into the bus cycle as long as nWAIT is asserted.
nWEH	High byte write enable.
nWEL	Low byte write enable.
OBIT1	General purpose output bit.
PCLK	Phase-synchronized reference signal that indicates the CPU bus cycle phase. 0 = phase 1, 1 = phase 2.
TURBO	Changes the speed of the system clock. 1 = 32 MHz, 0 = 8 MHz.
VBACK7	Backup 5 volts for DRAM.
VIN	Rectified AC—ranges from 15 to 31 volts depending on line voltage and load.
WRn	Write/Read. CPU control bus signal. Distinguishes write cycles from read cycles.

**Table A-9. Disk Power Connector J14**

Pin	Signal
1	+5V
2	GROUND
3	GROUND
4	NC

**Table A-10. Disk Drive Logic Connector J15**

Pin	Signal	Pin	Signal
1	GROUND	18	DIRECTION
2	+5V	19	GROUND
3	GROUND	20	STEP
4	NC	21	GROUND
5	GROUND	22	WRITEDATA
6	DRV3SEL	23	GROUND
7	GROUND	24	WRITEGATE
8	INDEX	25	GROUND
9	GROUND	26	TRK00
10	DRV0SEL	27	GROUND
11	GROUND	28	WRITEPROTECT
12	DRV1SEL	29	GROUND
13	GROUND	30	READDATA
14	DRV2SEL	31	GROUND
15	GROUND	32	SIDE1SEL
16	MOTOR ON	33	GROUND
17	GROUND	34	DISKCHANGE

Signal	Definition
DIRECTION	Determines the direction of the read/write head movement.
DISKCHANGE	Indicates to the system that the disk has been removed from the drive. Goes low when the disk is removed; goes high when a disk is reloaded and a step pulse is received from the system.
DRV0SEL, DRV1SEL, DRV2SEL, DRV3SEL	Drive select signals.
INDEX	A once-per-revolution pulse that indicates the beginning of a track on the disk.
MOTOR ON	Controls the operation of the drive motor when a disk is loaded.
READDATA	Data read from the disk and sent to the system.
SIDE1SEL	Selects the side of the disk to be used.
STEP	A pulse signal that moves the heads in the direction specified by DIRECTION.
TRK00	Indicates to the system that the heads are positioned at the outermost track (track 00).
WRITEDATA	Data from the system that is written on the disk.

**A-10 Connector Pin Assignments**

WRITEGATE Enables data writing on the disk.  
 WRITEPROTECT Indicates to the system that the disk is write protected.

## Preview Display Connectors

These tables list the pin assignments for the connectors on the preview display circuit boards. J2 on the preview display logic board connects to the cardiograph's system expansion connector, J12. Its pin assignments are listed in Table A-3. The preview display is an option available only on the M1700A cardiograph.

**Table A-11.**  
**Preview Display Logic Board, J1, to**  
**Preview Display Power Supply Board, J2**

Pin	Signal	Pin	Signal
1	VIN	11	UD0
2	VIN	12	UD1
3	POWERGND	13	+5VF
4	POWERGND	14	GROUND
5	LD2	15	SCP
6	LD3	16	GROUND
7	LD0	17	FP
8	LD1	18	LP
9	UD2	19	VLCDEN
10	UD3	20	GROUND

Signal	Definition
+5VF	A filtered version of the system +5V.
FP	Frame pulse. Clocks in one screen of LCD data.
LD0-LD3	Data bits for lower half of preview screen.
LP	Latch pulse. Clocks in one line of LCD data.
POWERGND	Power ground return for VIN.
SCP	Shift clock pulse. Clocks in upper and lower LCD data.
UD0-UD3	Data bits for upper half of preview screen.
VIN	15 to 31 V dc depending on line voltage and load.
VLCDEN	LCD enable signal

Table A-12. Power Supply to LCD Module, J1

Pin	Signal
1	VCFL1
2	VCFL2
3	NC
4	NC
5	VCFLRET

Signal	Definition
VCFLRET	Return path for cold fluorescent backlight power.
VCFL1, 2	Power for cold fluorescent backlights.

Table A-13. Power Supply to LCD Module, J2

Pin	Signal	Pin	Signal
1	FP	9	UD0
2	LP	10	UD1
3	SCP	11	UD2
4	NC	12	UD3
5	NC	13	LD0
6	VCCFILT	14	LD1
7	GROUND	15	LD2
8	VLCD	16	LD3

Signal	Definition
FP	Frame pulse. Clocks in one screen of LCD data.
LD0-LD3	Data bits for lower half of preview screen.
LP	Latch pulse. Clocks in one line of LCD data.
SCP	Shift clock pulse. Clocks in upper and lower LCD data.
UD0-UD3	Data bits for upper half of preview screen.
VCCFILT	Filtered +5V.
VLCD	Contrast voltage to the preview display.

## M1754A Signal Averaged ECG (SAECG) System

---

### Introduction

The M1754A SAECG System enables the PageWriter XLi to detect, display, and record high-frequency, low-amplitude (in the 2 to 20 microvolt range) ECG signals. The system can also detect mid-QRS micro-potentials not detected by conventional SAECG filtering techniques.

### Note



The SAECG application requires the A.02.XX and higher (M1755A) software. The SAECG Patient Module also acquires standard 12 lead ECGs.

The SAECG application cannot reside on the cardiograph with the VCG application.

---

The SAECG software uses an XYZ lead configuration to acquire and average about 200 heartbeats. Averaging these beats allows the physician to determine whether micro-potentials exist following the QRS. These micro-potentials can indicate if the patient is at risk of sudden death from ventricular arrhythmia.

The M1754A System consists of a software disk and a high-resolution patient module. The system is easy to learn and use, and provides full signal-averaging capability while eliminating the need for dedicated SAECG equipment. The SAECG System continuously displays real-time waveforms, averaged waveforms, and noise level information on the XLi cardiograph's preview screen. The system provides three user-selectable high-pass filters (25, 40, and 80 HZ), and allows you to select either number of beats or noise level as the termination criteria. The system also allows you to adjust QRS onset and offset in all filtered leads and final vector composite, and automatically displays all QRS templates for verification. An adjustable template window lets you perform P wave averaging and HIS bundle analysis.

A patented BiSpec filter provides undistorted detection of potentials and preserves data integrity and comparability. Measurements made by the M1754A System correlate with accepted threshold criteria. The system meets or exceeds all applicable ACC/AHA recommendations for SAECG, and conforms to all applicable IEC, VDE, UL, CSA, AHA, and AAMI ECG specifications.

## Installation and Configuration

### Connecting the Patient Module

1. Connect the patient data cable to the ECG input jack on the back of the cardiograph.
2. Connect the other end of the patient data cable to the patient module as shown in Figure B-1.
3. Connect the leadwires to the patient module. Match the color coding on the leadwires to the color coding on the patient module.
4. Install shorting plugs in the patient module in those positions without leadwires.

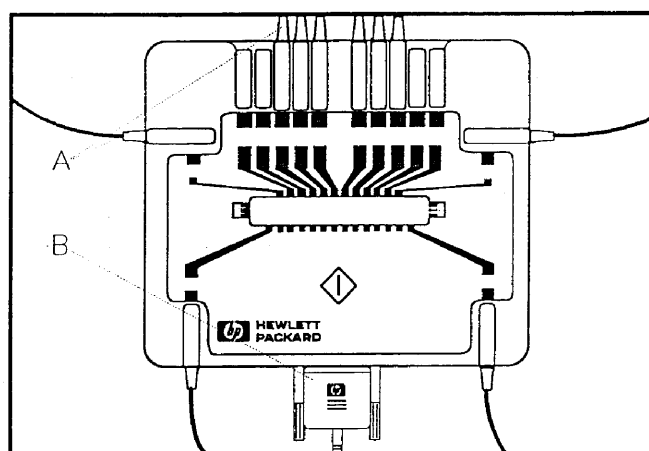

Figure B-1. Connecting the Patient Module.

- A. Leadwires
- B. Patient Data Cable

### Note



The M1754A SAECG patient module can acquire both SAECG and standard ECGs. To get the best results for SAECG, remove the LL and LA leadwires and install shorting plugs in the LL and LA inputs.

## Installing the SAECG Software

To install the M1754A SAECG application software perform the following steps.

### Note



Version A.02.XX or A.03.00 software must already be installed in the cardiograph prior to installing SAECG software.

1. Press the **On-Standby** switch to place the cardiograph in Standby.
2. Insert the M1754A SAECG application disk in the cardiograph.
3. Press **On-Standby** to turn the cardiograph **On**. The message Load SAECG application? appears.
4. Press **Yes**. The copyright display appears briefly, then the following display appears:

```
*****  
SAECG (M1754A - A.01.00)
```

The asterisks gradually extend across the display as the software is installed. When installation is complete, the following display appears:

```
Auto      3x4  
Report    Format      01-26-92   01:23PM
```

**SAECG Configuration  
(A.02.XX and higher  
Software Only)**

**Note**



SAECG configuration can only be accessed from the SAECG application. Select **Config** from the following SAECG menu.

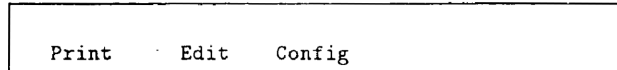

Table B-1 and Table B-2 show the configuration options for the M1754A SAECG application. The default settings appear in bold type. These defaults are adequate for most applications.

**Acquisition Fields**

Table B-1 shows the choices available to configure acquisition.

**Table B-1. Acquisition Configuration Fields**

Parameter	Setting Choices	Comments
Fiducial point?	Left Center Right	The peak of the QRS can be moved from the center to the right or left third of the display and the printed report. The noise window is moved by the same amount as the fiducial point.
Correlation coefficient? (0.01 - 0.99)	0.99	This controls how closely the acquired beats must match the template. A value of 0.99 means the acquired beats must match the template as closely as possible.
Average to?	Noise level Beats	The end of the averaging process is controlled by either the average noise level of the three leads, or by a total number of accepted beats.
Number of beats? (1 - 9999) <sup>1</sup>	200	The total beats that must be collected before the process completes.
Noise level? (0 - 100 $\mu$ V) <sup>2</sup>	0.3 $\mu$ V	The noise level required before the process completes.
Automatic file naming?	Yes No	This controls whether the file is named automatically. Manual file naming is used for easier file exchange with the Corazonix Predictor <sup>®</sup> .

<sup>1</sup> This field appears only if **Beats** is selected in the **Average to?** field.

<sup>2</sup> This field appears only if **Noise level** is selected in the **Average to?** field.

## Measurement Fields

Table B-2 shows the choices available to configure measurement.

**Table B-2. Measurement/Processing Configuration Fields**

Parameter	Setting Choices	Comments
Filter frequency?	40 80 25	This sets the frequency of the high-pass filter.
Unfilt. lead scaling?	Auto Manual	This sets the automatic scaling of the unfiltered leads on the printed report.
Unfilt. lead scale? <sup>1</sup>	100 $\mu\text{V}/\text{mm}$	The scale used for unfiltered leads on the printed reports.
Filt. lead scaling?	Auto Manual	This sets the automatic scaling of the filtered leads on the printed report.
Filt. lead scale? <sup>2</sup>	5 $\mu\text{V}/\text{mm}$	The scale used for filtered leads on the printed reports.
Vector scaling?	Auto Manual	This sets the vector scaling on the printed report.
Vector scale? <sup>3</sup>	2 $\mu\text{V}/\text{mm}$	The vector scale used on the printed reports. Vector scaling can also be changed during editing.

<sup>1</sup> This field appears only if **Manual** is selected in the **Unfilt. lead scaling?** field.

<sup>2</sup> This field appears only if **Manual** is selected in the **Filt. lead scaling?** field.

<sup>3</sup> This field appears only if **Manual** is selected in the **Vector scaling?** field.

## Operation

### SAECG (M1754A Only)

The SAECG application allows you to use your PageWriter XLi cardiograph to acquire signal-averaged ECGs for use in detecting late potentials. (SAECG requires A.02.XX or higher revision software, SAECG application software and an SAECG Patient Module.)

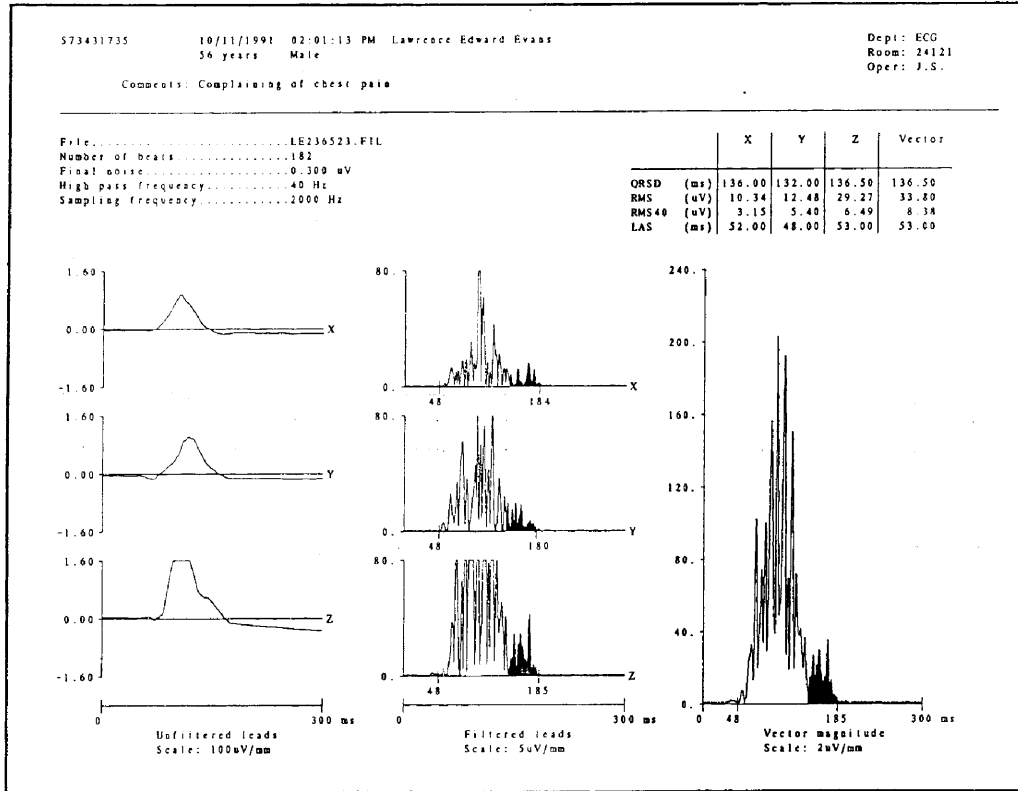

Figure B-2. An SAECG Report.

## Using SAECG

To use SAECG, do the following:

1. Press **Menu** until the applications menu appears in the display:

```
Applications
XLi      Prev+  SAECG
```

### Note



If the applications menu does not appear, press **Menu** until the following appears in the display:

```
Prev+
Reformat  Timed  ContPrev  Delayed  Exit
```

Press **Exit** to display the applications menu.

2. Press **SAECG**. A display similar to the following appears:

```
SAECG
Start      02/13/92  10:22AM
```

3. Press **Start**. The message **Determining template beat ...** appears, followed by this display:

```
Select the template.
Select  Reject  Match   Noise   Exit
```

In addition, the template beat with the matching and noise windows appears on the preview screen as shown in Figure B-3.

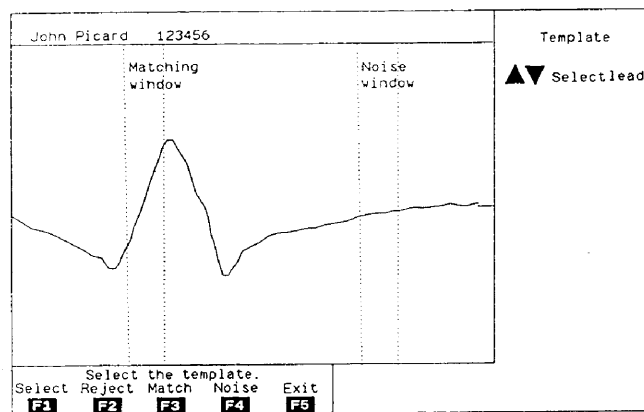

Figure B-3. A Template Screen.

- Select** Confirms the displayed template beat. (The template beat is a typical beat used to match other beats during averaging.) You must do this before you can start the SAECG process.
- Reject** Rejects the displayed template beat and acquires another.
- Match** Lets you adjust the matching window. Use the **◀** and **▶** keys to position the window, then press **Done**. Make sure the matching window contains the fastest rising portion of the R wave.
- Noise** Lets you adjust the noise window. Use the **◀** and **▶** keys to position the window, then press **Done**. Make sure the noise window is on a flat part of the signal, and that the T wave is not inside the window.
- ▲** and **▼** Allow you to place the template on another lead.

4. Once you have selected a template beat, the message **Averaging ...** appears, and the preview screen displays continuous ECG signals for leads X, Y, and Z.

**Note**



You can press **Done** at any time to end the averaging process.

5. When the averaging process is complete, the message Filtering averaged beats ... appears, followed by this display:

Adjust the onset and offset.				
Print	Onset	Offset	Lead	Exit

**Print** Prints and stores the SAECG report. If your application is configured for manual file naming, you will be prompted to name the file after it prints. The name can have up to eight characters followed by a three-digit extension; for example, MKEATING.001. Press **Done** to store the report.

**Onset** Allows you to adjust the QRS onset marker. When you press **Onset** or **Offset**, the following display appears:

Adjust the onset.	
Done	Exit

Use the **◀** and **▶** keys to move the onset window, then press **Done**.

**Offset** Allows you to adjust the QRS offset marker (see above).

**Lead** Lets you view another lead. When you press **Lead**, the following display appears:

Choose another lead.				
Vector	X	Y	Z	Exit

Press **X**, **Y**, or **Z** to view that lead, or press **Vector** to view the combined vector lead. You can adjust the onset and offset for each lead independently and for the combined vector lead.

### Editing and Printing a Stored SAECG

To edit or print a stored SAECG report:

1. Press **Menu** until the following display appears:

```
Print      Edit      Config
```

2. Press **Edit**. A display similar to the following appears:

```
Edit ID#: 12345678
Select      Next      Previous      Exit
```

3. Press **Next** or **Previous** until the patient ID number you want appears.
4. Press **Select**. The onset/offset adjust menu shown earlier appears.

#### Note



If you know the patient ID number of the ECG you want to edit or print, you can select the ECG as follows:

- Press **More**, then **Find**.
- Type the patient ID number. Press **Enter**. The most recent ECG with that patient ID number appears.
- If you want a different ECG for that patient, you must scroll through the list by pressing **Previous**.
- When the ID number you want appears, press **Select**.

You can now adjust the onset and offset and print the report as described earlier.

#### Deleting a Stored SAECG

You can delete SAECGs from the main XLI menu by selecting the SAECGs to be deleted and pressing **Delete**.

---

## Performance Verification and Maintenance

### Extended Self-test

The cardiograph's Extended Self-test, loaded as part of the system software, tests each major subassembly. The display tests and the printer test require visual verification of displayed or printed output.

In most cases, a test failure halts the test and a message indicating the failure appears on the keyboard display. In the case of the tests that require visual verification, visible failure symptoms appear in the printed or displayed test pattern. See the "Troubleshooting," section for a list of self-test failure messages and failure symptoms.

To begin the Extended Self-test, press **On-Standby** to turn on the cardiograph, then quickly press and release the **Alt** and **X** keys simultaneously. The following display will appear:

Test: All					
Select	Test	Next	Previous	ErrorLog	

The upper line displays the test choice, while the lower line displays the softkey labels. With the softkeys you step through the test menu, select tests, and initiate testing.

**Select** Selects the test displayed in the message line. Asterisks (\*) appear around the test name to indicate its selection. If the test is already selected, pressing this key de-selects the test (the asterisks disappear). You can select one or more tests in any combination, but the sequence is fixed.

**Test** Begins running the selected test(s).

**Next** Steps forward through the test menu.

**Previous** Steps backward through the test menu.

**ErrorLog** Prints out the stored error log.

To stop or exit Extended Self-test, you must press **On-Standby** to place the cardiograph in Standby.

These are the tests available in Extended Self-test:

- Patient module and cable
- CPU assembly
- Printer
- Disk drive (M1700A and M1701A only)
- Preview display (M1700A only)
- Keyboard display
- Modem and cable (M1700A only)
- All

The patient module and cable test is described in more detail in the discussions that follow.

#### **Patient Module and Cable Test**

This test looks for failures in the patient module and patient data cable, and generates a test pattern in the patient module display.

If the patient module fails the test, the message **Patient module test failed.** appears on the keyboard display. If the cable fails the test, the message **Patient module cable test failed.** appears.

#### **Note**



---

The patient module test does not test the patient electrodes or leadwires. Test the patient electrodes and leadwires by recording an ECG from a patient or ECG simulator as described later in this section.

---

The test patterns displayed on the patient module consist of (in this order):

- all white cells
- checkerboard cells
- all black cells
- inverse checkerboard cells
- 80 characters (displayed in 5 successive groups of 16)
- all white cells

You must observe the patient module display while the test pattern is running to ensure:

- accurate rendition of all patterns and characters
- no random lines or dots are displayed

Before and after the tests, asterisks appear in the display.

---

## Theory of Operation

### The SAECG Patient Module

In standard mode, the SAECG patient module operates as described in "The Standard Patient Module," to acquire "classical" ECGs. In SAECG mode, the SAECG patient module operates as in standard mode except for the following:

- The module collects data from 6 electrodes.
- The multiplexors sample the data twice in each sampling period, giving a functional sample rate of 8 kHz instead of 4 kHz.
- SAECG mode increases amplifier gain and analog-to-digital conversion resolution by a factor of approximately 4.1. This provides better signal resolution and reduces system noise.

You can use SAECG mode with all four limbwires (RA, LA, RL, LL) attached. However, you will get better results if you attach only RA and RL, and insert shorting plugs in LA and LL. This is because the common mode rejection performance is enhanced if the LL and LA inputs have shorting plugs installed. The SAECG software does not include line frequency rejection; since the signals of interest are smaller than in standard mode, common mode rejection becomes critical.

Figure B-4 shows a block diagram of the SAECG patient module's circuitry.

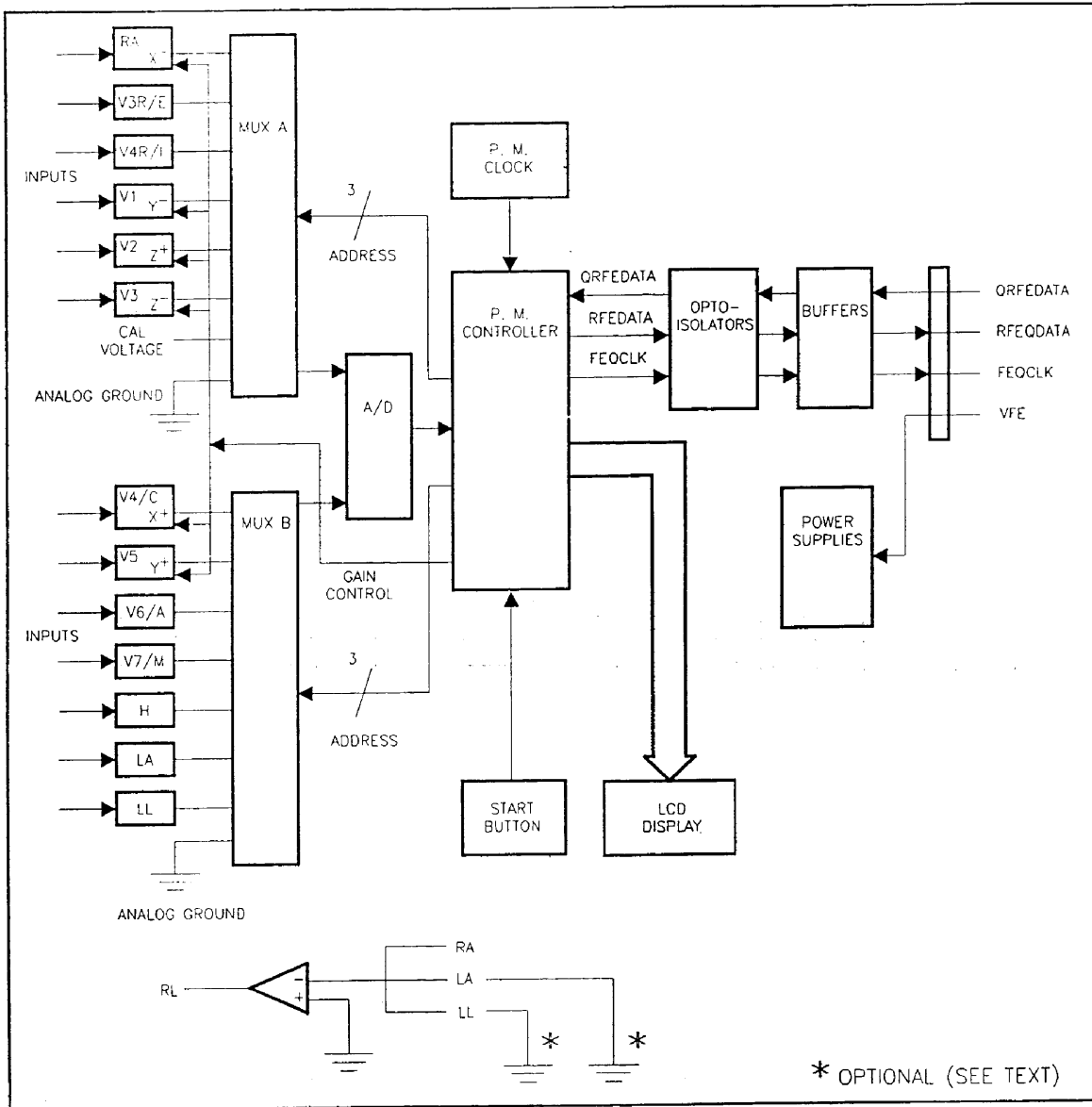

Figure B-4. SAECG Patient Module Block Diagram.

## Troubleshooting

Table B-3. SAECG Testing Problems

Symptom	What to Do
Message: 6503 appears.	The XLI cardiograph software has not yet been installed. Install the XLI software before installing the SAECG software.
Message: No room to load application. appears.	Delete another application such as Preview Plus, before installing the SAECG application.
Message: Attach SAECG patient module. appears.	Attach the SAECG patient module before attempting to use the SAECG application.
Message: No heartbeat. Check connections. appears.	A lead might not be connected. Refer to Chapter 1 for information on how to apply electrodes for an SAECG.
The noise stops decreasing during averaging.	A lead might be off. Check the leads and continue or restart the SAECG test.
The application does not average to the preset level of noise.	The ECG signal is too noisy.

Table B-4. Patient Module and Patient Data Cable

Symptom	Cause	Corrective Action
Noisy lead X.	Poor electrode contact (X <sup>-</sup> or X <sup>+</sup> ). X <sup>-</sup> or X <sup>+</sup> leadwire defective.	Refer to <i>M1754A SAECG User's Manual</i> . Replace leadwire.
Noisy lead Y.	Poor electrode contact (Y <sup>-</sup> or Y <sup>+</sup> ). Y <sup>-</sup> or Y <sup>+</sup> leadwire defective.	Refer to <i>M1754A SAECG User's Manual</i> . Replace leadwire.
Noisy lead Z.	Poor electrode contact (Z <sup>-</sup> or Z <sup>+</sup> ). Z <sup>-</sup> or Z <sup>+</sup> leadwire defective.	Refer to <i>M1754A SAECG User's Manual</i> . Replace leadwire.
No SAECG waveforms.	LA or LL not terminated.	Install shorting plugs or connect LA and LL to patient.

---

## Parts List

Table B-5. SAECG Parts List

Description	Part No.
SAECG patient module, AHA (M1700A)	M1700-69511
SAECG patient module, IEC (M1700A)	M1700-69512
Patient data cable, 2.5 M	M1719A
Patient data cable, 9.0 M	M1720A
Label for SAECG patient module, AHA (M1700A)	M1700-84589
Label for SAECG patient module, IEC (M1700A)	M1700-84590
Module end label	M1700-84521
Software set, SAECG, version A.01.00 (M1754A)	M1754-17700

## M1756A Direct Digital ECG Fax

---

### Introduction

The M1756A option lets the XLi transmit high-quality ECGs to any CCITT Group 3 fax machine, or to any XLi equipped with direct digital fax. The M1756A also enables the XLi to receive fax transmissions from any Group 3 fax machine. Fax capability is ideal for transmitting ECGs to sites that do not have a cardiograph or ECG management system.

### Note



---

Fax modem transmission requires the A.02.XX and higher (M1755A) software. The FAX Modem also functions in place of the M1706A Hayes Modem for standard ECG transmissions.

---

Typical fax machines send ECGs by optically scanning a paper copy of the ECG. This often produces low-quality faxes not always adequate for making diagnoses. In contrast, the M1756A transmits the electronic ECG directly from the XLi, without scanning a paper copy. This produces faxes of exceptional quality.

The M1756A fax option can be used by service personnel to receive faxed support information directly on the XLi.

The M1756A option consists of a Worldport 2496<sup>TM</sup> Fax/Data modem and a software disk. A 9-volt battery allows up to 3 hours of transmission while the XLi is on battery power. The fax modem can also be powered from the cardiograph.

---

## Installation and Configuration

The following table lists the settings to choose to configure the system to use a fax modem.

### Note



Each site may have different requirements. Only ECGs may be faxed. SAECGs and VCGs may not be faxed.

Parameter	Choice
Connection?	FAX Programmable Modem
Baud Rate?	2400
Phone #?	Type phone number, 36 characters max.
Dial Type?	Tone Pulse
Pause Length?	2, 4, 6, 8, 10 (secs)
Destination?	Type name, 22 characters maximum.
Print grid on report?	Yes, No (A.03.XX only)

## Operation

The fax modem allows you to send and receive ECGs using standard fax machines. The cardiograph must be configured for these functions before you can use them. (See chapter 2 for information about configuring your cardiograph for transmitting ECGs.) Fax transmission also requires A.02.XX revision software.

### Transmitting ECGs by Fax

After the cardiograph has been configured to use a site for fax transmission, you can fax an ECG to the site. To transmit an ECG:

1. Press **Menu** until the following display appears.

```
Transmit Store   Config CheckDisk Files
```

2. Press **Transmit**. The following display appears.

```
                Transmit
Selected  All   NewGroup  Query   Exit
```

3. Press **Selected**. The message Reading the disk appears, followed by this display:

```
123456                02-13-92   12:09:41PM
Select  Transmit Next  Previous  More
```

4. Press **Next** or **Previous** until the patient ID number you want appears, then press **Select**.

### Note



If you know the patient ID number of the ECG you want to transmit, you can select the ECG as follows:

- Press **More**, then **Find**.
- Type the ID number and press **Enter**. The most recent ECG with that ID number appears.
- If you want a different ECG for that patient, scroll through the list by pressing **Previous**.
- When the ID number you want appears, press **Select**.

5. Press **Transmit**. The following display appears:

```
                Choose site
1                2          3          4          Manual
```

6. Press the key under the number of the intended receiving site. This number corresponds to the receiving site previously

configured. Messages such as *Calling site*, *Connected to site*, *Transmitting ...*, and *Transmitting 1 of 1 ECG(s)* might appear.

7. When the ECG has been successfully transmitted, the message *1 ECG(s) Transmitted* appears.
8. Press *Exit* to continue.

#### Transmitting More than One ECG

- To transmit several ECGs, follow the same steps as above, but select all the ECGs you want to transmit. After selecting the ECGs, press *Transmit*.
- To transmit all stored ECGs, follow the same steps as above, but press *Transmit All* instead of *Transmit Selected*.
- To transmit all ECGs that have not been previously transmitted, follow the same steps as above, but press *Transmit NewGroup* instead of *Transmit Selected*.
- *Manual* allows you to transmit to a site that has not been configured.

#### Note



---

See the *PageWriter XLi User's Reference Guide* for more information about transmitting ECGs.

---

#### Receiving ECGs

The cardiograph can receive ECGs from a fax machine whenever it is turned on, configured for fax modem usage, and idle. If the cardiograph is turned off, it cannot receive ECGs. All ECGs are printed as they are received. You cannot edit or store received ECGs.

You can stop receiving the ECGs any time by pressing *Stop*.

#### Note



---

The fax modem can also transmit ECGs to receivers other than fax machines. When configured as a programmable modem, the fax modem performs in the same manner as the M1706A Hayes® modem.

---

---

## Performance Verification and Maintenance

### Extended Self-test

The cardiograph's Extended Self-test, loaded as part of the system software, tests each major subassembly. The display tests and the printer test require visual verification of displayed or printed output.

In most cases, a test failure halts the test and a message indicating the failure appears on the keyboard display. In the case of the tests that require visual verification, visible failure symptoms appear in the printed or displayed test pattern. See Chapter 6, "Troubleshooting," for a list of self-test failure messages and failure symptoms.

To begin the Extended Self-test, press **On-Standby** to turn on the cardiograph, then quickly press and release the **Alt** and **X** keys simultaneously. The following display will appear:

Test: All
Select      Test      Next      Previous      ErrorLog

The upper line displays the test choice, while the lower line displays the softkey labels. With the softkeys you step through the test menu, select tests, and initiate testing.

- |                 |  |
|-----------------|--|
| <b>Select</b>   | Selects the test displayed in the message line. Asterisks (*) appear around the test name to indicate its selection. If the test is already selected, pressing this key de-selects the test (the asterisks disappear). You can select one or more tests in any combination, but the sequence is fixed. |
| <b>Test</b>     | Begins running the selected test(s).   |
| <b>Next</b>     | Steps forward through the test menu.   |
| <b>Previous</b> | Steps backward through the test menu.  |
| <b>ErrorLog</b> | Prints out the stored error log.   |

To stop or exit Extended Self-test, you must press **On-Standby** to place the cardiograph in **Standby**.

These are the tests available in Extended Self-test:

- Patient module and cable
- CPU assembly
- Printer
- Disk drive (M1700A and M1701A only)
- Preview display (M1700A only)
- Keyboard display
- Modem and cable (M1700A only)
- All

The modem and cable test are described in more detail in the discussions that follow.

#### **Fax Modem Test (M1700A Only)**

The modem test checks the operation of the Worldport 2496™ fax modem.

#### **Note**



---

The fax modem may have a 9 V battery installed. If a battery is not installed, the cardiograph should be connected to AC voltage to test the fax modem.

---

If the fax modem passes the test, the message **Modem firmware checksum: xxx.** appears. If the modem fails the test, the message **Modem test failed.** appears on the keyboard display.

#### **Note**



---

If the M1700A is not equipped with a modem, selecting the modem test results in a test failure. If you have selected the "All" test choice, remove the modem test from the selected tests to avoid an erroneous test failure.

---

## Troubleshooting

Table C-1. Transmit and Fax

Symptom	Cause	Corrective Action
Message: No answer at site.	Cabling problems between fax modem and cardiograph. Telephone line or telephone cable defective.	Perform Extended Self-test modem test. Substitute normal telephone for fax modem and dial number. Ensure that fax answers with high-pitched tone.
Extended Self-test modem test failure	RS-232 cable not plugged in or defective. Power cable not plugged in or defective, or cardiograph AC off. Fax modem not turned on.  Fax modem battery bad. Defective fax modem. Defective CPU assembly.	Plug in to cardiograph; if defective, replace. Plug in to cardiograph and turn on AC; if defective, replace. Turn on Fax modem. Check for unplugged or defective power cable. Replace battery. Replace fax modem. Replace CPU assembly.
Unable to transmit or receive. Modem passes Extended Self-test.	Phone cable unplugged or defective.  Configuration changed without cycling power. Defective fax modem. Defective CPU assembly. 9V power missing.  ECG disk is write-protected.	Plug in phone cable; if defective, replace.  Cycle power on cardiograph. Replace fax modem. Replace CPU assembly. Check voltage at cardiograph power connector. Move write-protector tab.
Black or white lines appear on the fax.	Noisy phone lines lose fax data.	Call again, if possible on another phone line.

**Note**



The fax modem does not require a battery for operation when the cardiograph is connected to AC power. However, the fax modem cannot receive when operating from the battery.

## Parts List

Table C-2. Fax Modem Parts List

Description	Part No.
Screw, 10-32, knurled for fax modem	0370-3219
Fax modem (Canada)	M1756-89502
Fax modem (France)	M1756-89503
Fax modem (Italy)	M1756-89506
Fax modem (Netherlands)	M1756-89504
Fax modem (United Kingdom)	M1756-89505
Fax modem (United States)	M1756-89501
Fax modem bracket	M1756-07300
Standard fax modem cable	M1756-61600

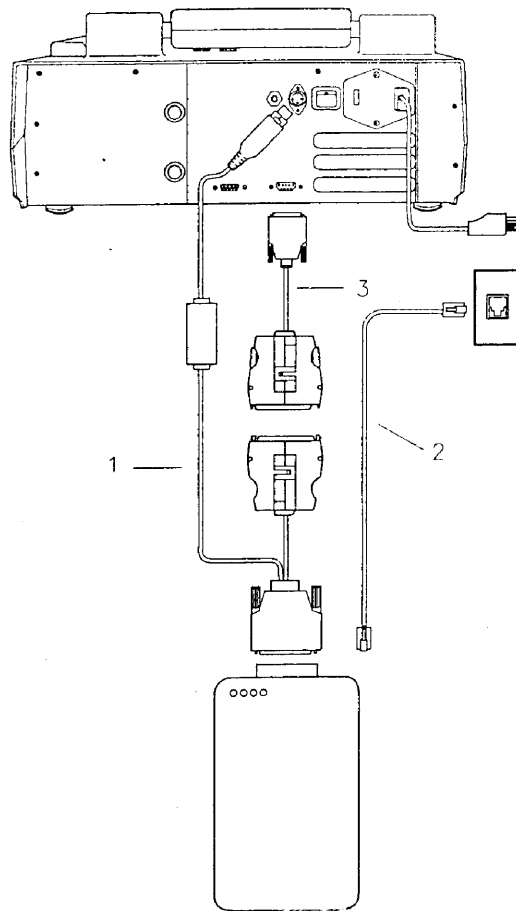

**Figure C-2.**  
**Cabling for FAX Modem and Direct Connect (Quick Connect) Transmission**

**Table C-4.**  
**Fax Modem and Quick Connect Cable Parts List**

Ref No.	Description	Part No.
1	FAX Quick Connect Cable	M1756-61601
2	Phone Line Cable	See table 8-11
3	Quick Connect Cable	M1706-61636

**Note**



The M1706-61636 cable functions as a direct connect cable when separated from M1756-61601

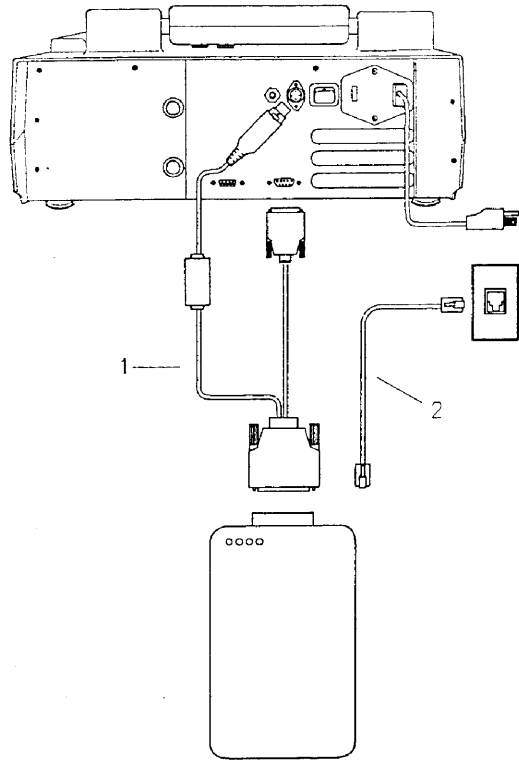

**Figure C-1. Cabling for FAX Modem Transmission Only**

**Table C-3. Fax Modem Cable Parts List**

Ref No.	Description	Part No.
1	FAX Modem Cable	M1756-61600
2	Phone Line Cable	See table 8-11

## Vectorcardiography M1790A

---

### Introduction

**Note**

The VCG application requires the A.03.XX software. The VCG application cannot reside on the cardiograph with the SAECG application.

---

The M1790A VCG system adds vector loops reporting capability to the PageWriter XLi cardiograph. The Vectorcardiogram (VCG) is a recording of the changes in spatial orientation, direction and magnitude of the electrical activity of the heart. The VCG application requires the use of three orthogonal leads (X, Y, Z). The PageWriter XLi cardiograph's patient module can be set up to use Frank leads which provide the X, Y, and Z leads.

If the X,Y,Z leads were connected when the ECG was acquired and one of the VCG report formats was configured, a one page VCG report will be printed immediately after the ECG report any time an ECG is printed on the cardiograph. One of the following Auto ECG report formats must be selected in order to record a VCG:

- 3x4,1R configured with an X,Y or Z rhythm strip
- 3x4,3R configured with X,Y,Z rhythm strips

**Note**

The M1730A TraceMaster ECG Management System does not print a VCG, although you can store VCG data to the system from a disk.

---

Research has shown that VCGs offer incremental diagnostic value over conventional 12-lead ECGs in the areas of atrial enlargement, right ventricular hypertrophy, and in the recognition of certain infarctions.

## Installation and Configuration

VCG recording requires that you use the Frank lead set in addition to the standard 12-lead set to obtain the VCG from the patient. The following information describes how to set up the patient module and attach leads to the patient for VCG recording.

### Setting Up the Patient Module

To set up the patient module, perform the following steps.

1. Turn off the cardiograph.
2. Replace the four shorting plugs on the patient module with Frank lead wires I, E, M, H. Optionally, you may replace V4 (C4) and V6 (C6) chest lead wires with Frank lead wires C and A.
3. Turn on the cardiograph.

The following tables describe how to set up the patient module for the lead set you are using.

**Table D-1.**  
**AHA Lead Set and Patient Module Configurations**

Lead	Lead Color Code	Label Color	Slot Label
I	Orange/Red	Red	V4R
E	Orange/Yellow	Yellow	V3R
C	Orange/Green	Blue	V4
A	Orange/Brown	Violet	V6
M	Orange/Black	Black	V7
H	Orange/Violet	Violet	H

**Table D-2. IEC Lead Set and Patient Module**

Lead	Lead Color Code	Label Color	Slot Label
I	Light Blue/Red	Grey	C4R
E	Light Blue/Yellow	Pink	C3R
C	Light Blue/Green	Brown	C4
A	Light Blue/Brown	Violet	C6
M	Light Blue/Black	Orange	C7
H	Light Blue/Violet	Violet	H

## Software Installation

### Note



Version A.03.1X software must be installed in the cardiograph prior to installing VCG software.

To install the M1790A VCG software, perform the following steps.

1. Press **On-Standby** to place the cardiograph in Standby.
2. Insert the application disk, labeled "VCG Disk," in the disk drive in the front of the cardiograph.
3. Turn on the cardiograph. The message Load VCG Application? will appear.
4. Press **Yes**. When installation is complete, the following display appears:

Auto	3x4		
Report	Format	01-26-92	01:23PM

### VCG Configuration (A.03.XX Software Only)

To configure the PageWriter XLi cardiograph for VCG recording, perform the following steps.

1. Press **Menu** twice until the following display appears.

Transmit	Store	Config	CheckDisk	Files
----------	-------	--------	-----------	-------

2. Press **Config**. The main configuration menu will appear.

		Configuration		
Global	ID	Transmit	Files	Exit

3. Press **Global** for global configuration selections.
4. Select the VCG choices as shown in Table D-3.
5. Press **Exit** twice when you have finished configuring your cardiograph.

Table D-3 lists global configuration parameters and choices you need for VCG recording.

Table D-3. Global Configuration Fields

Parameter	VCG Setting Choices	Comments
Special applications?	Yes	
Research leads?	No	Select "No" to enable Frank leads.
ECG storage mode?	Standard (250 samples/second) Special (500 samples/second)	Special is the preferred mode for VCG storage.
VCG?	Off VCG1 (0° to 360°, right sagittal) VCG2 (0° to 360°, left sagittal) VCG3 (-180° to +180°, right sagittal) VCG4 (-180° to +180°, left sagittal)	Select "Off" to suppress the VCG report.

**Disabling VCG Reports** To reconfigure the cardiograph to disable VCG reports, select "Off" in the VCG? parameter of global configuration. Now, you cannot record VCGs until the cardiograph is reconfigured for VCG recording and the Frank lead set is attached.

## Operation

You must configure the cardiograph for VCG recording and have Frank leads attached to the patient in order to record a VCG.

### Recording a VCG

To record a VCG, perform the following steps.

1. Press **Stop**.
2. To select Auto report, press **Report** until Auto appears above Report.
3. Press **Format** to select the 12-lead Auto ECG report format. Select one of the two rhythm formats:  
3 x 4, 1R or 3 x 4, 3R.
4. Press **Leads** to select which leads are recorded for the rhythm strips. Select X, Y, or Z for the rhythm strip lead with the 3 x 4, 1R format and select X, Y, Z for the rhythm strip leads with the 3 x 4, 3R format. The VCG format representation that is currently configured will be displayed in parentheses next to the ECG format. Refer to the *VCG Report Formats* section later in this chapter for information about VCG report formats.
5. Press **Auto**. The VCG report will be printed after the ECG Auto report is printed.
6. Press **Copy** for additional copies.

**Printing a Stored VCG**

Print a stored VCG the same way you print a stored ECG. Select a file that has been acquired with Frank leads and press **Print**. Both the Auto ECG report and the VCG report will be printed.

**Preventing the VCG Report from Printing**

To prevent the one-page VCG report from printing when the patient is connected to Frank leads, select a report format that is not one of the following formats:

- 3 x 4, 1R X
- 3 x 4, 1R Y
- 3 x 4, 1R Z
- 3 x 4, 3R XYZ.

# The VCG Report

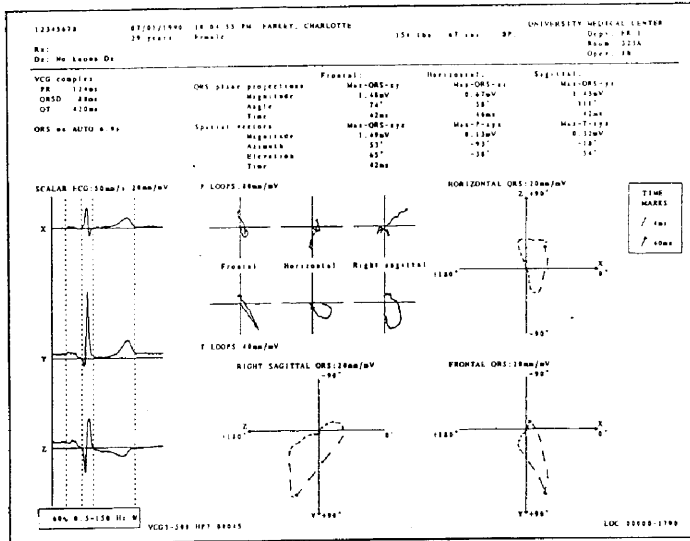

Figure D-1. The VCG Report

## VCG Report Formats

### Formats

The VCG formats correspond to the layout of the frontal, horizontal, and sagittal QRS loops and the angular scales used for the axes. There are four different VCG report formats: VCG1, VCG2, VCG3, and VCG4. Each report format shows a different relative position of QRS loops within the loop representation area and uses a different angular scale.

Table D-4. VCG Report Formats

Format	Sagittal Projection	Angular Scale
VCG1	Right sagittal	0° to 360°
VCG2	Left sagittal	0° to 360°
VCG3 <sup>1</sup>	Right sagittal	-180° to +180°
VCG4 <sup>1</sup>	Left sagittal	-180° to +180°

<sup>1</sup>Format conforms to the recommendations of the AHA.

The horizontal plane is always viewed from the head rather than the foot and the frontal plane is viewed from the chest and not the back. But, the sagittal plane is not standardized and can be viewed from either the left or the right side. Therefore, we support both the left and right sagittal projections in each of the two types of reports.

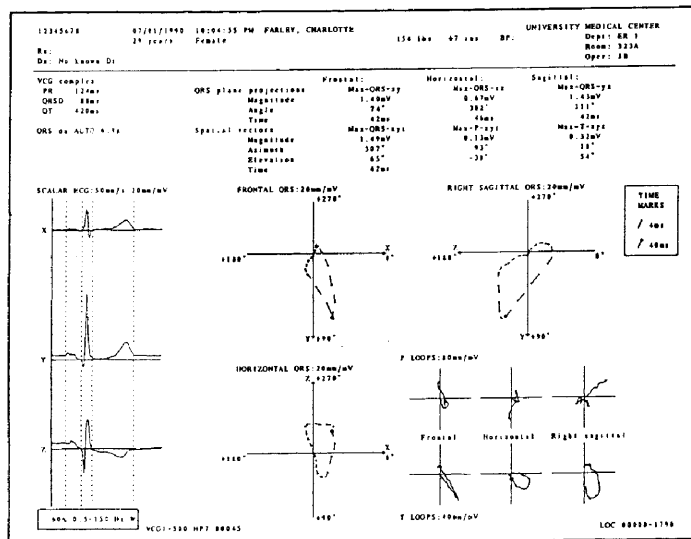

Figure D-2. VCG1: Right Sagittal, 0° to 360°.

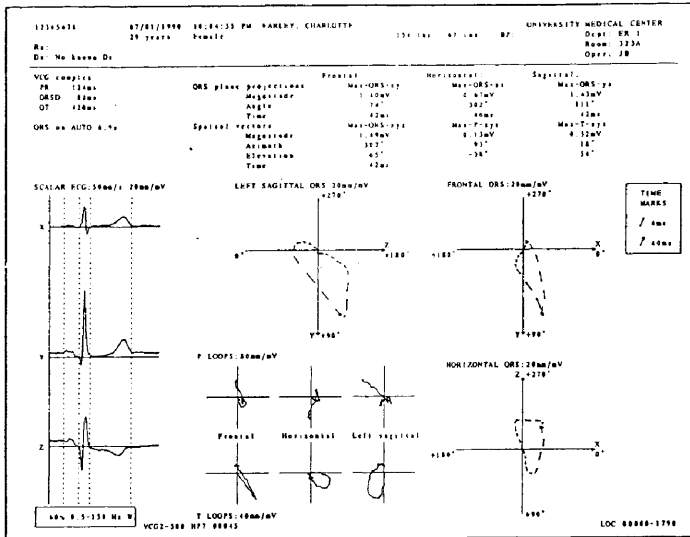

Figure D-3. VCG2: Left Sagittal, 0° to 360°.

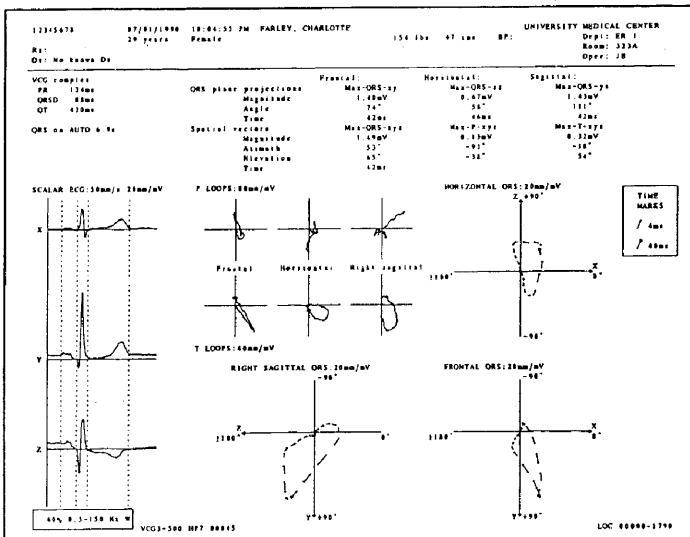

Figure D-4. VCG3: Right Sagittal, -180° to +180°.

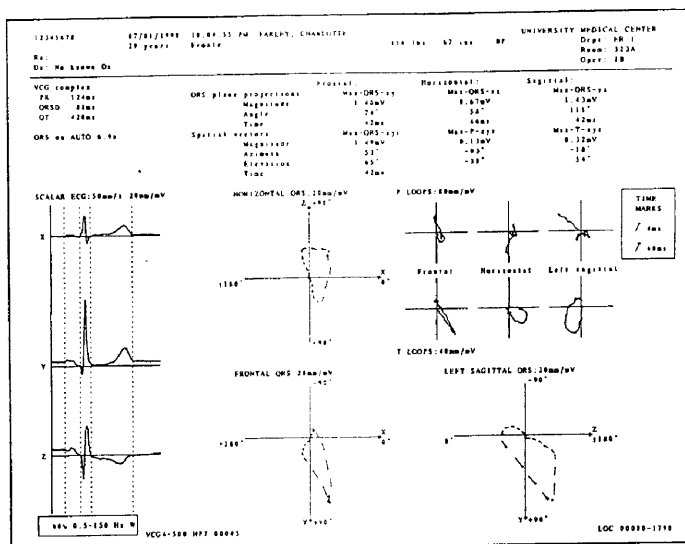

Figure D-5. VCG4: Left Sagittal, -180° to +180°.

## Manual Report Formats

When the cardiograph is configured for VCG recording, some manual report formats with Frank leads are automatically added to the list of formats from which you can choose. One of the manual 3-lead ECG report formats contains the X, Y, and Z leads. Another format is the custom 3-lead group, which can be set in the global cardiograph configuration to include any combination of three out of 15 leads.

### Caution



If you configure a custom 3-lead group, you must choose the X, Y, and Z leads in that sequence to be able to print a VCG report from that format. The VCG report cannot be printed unless the leads are presented in the correct sequence.

## Troubleshooting

This chapter contains information about troubleshooting the VCG recording.

Table D-5. Troubleshooting

Symptom	Cause	What to do ...
Extra lead labels VX1, VX2, VX3, VX4 appear in the cardiograph's display	Research leads instead of Frank leads are configured	In global configuration, under "Special applications", change the answer to the <b>Research leads?</b> question to "No" to enable Frank leads. Turn the cardiograph off and on again.
Extra lead labels V3R, V4R, and V7 instead of X, Y, and Z appear on the cardiograph's display	The Frank lead wires are not correctly plugged into the patient module. The H slot contains a shorting plug.	Be sure that all Frank lead wires are correctly plugged in. Be sure that all of the other leads are plugged into the patient module and that no shorting plugs are installed. Turn the cardiograph off and on again.

---

## Parts List

Table D-6. VCG Parts List

Description	Part No.
Software set, VCG, version A.01.00 (M1790A)	M1790-17700
Leadwire set, Peds/Frank (includes 2 Frank leads labels)	M1717B
Shorting plug	M1700-47602

Table D-5. Troubleshooting (continued)

Symptom	Cause	What to do ...
No VCG report is printed and the message Defective VCG data appears briefly on the cardiograph's display. The Electrode off message appears on the Auto ECG report.	One or more X, Y, Z leads are missing or the ECG line is flat.	Be sure that all Frank lead wires are correctly plugged into the patient module.
No VCG report is printed after the 12-lead Auto ECG report.	Incorrect 12-lead Auto ECG report format selected	Select either a 3 x 4, 1R format with an X, Y, or Z lead as rhythm strip or select a 3 x 4, 3R format with X, Y, and Z leads as rhythm strips.
	VCG report format not selected to enable VCG printing.	In global configuration, change the answer to the VCG? question to one of the four possible VCG report formats: VCG1, VCG2, VCG3, or VCG4.
No VCG report is printed from the stored VCG file.	A VCG format was not selected to enable VCG printing	In global configuration, change the answer to the VCG? question to one of the four possible VCG report formats: VCG1, VCG2, VCG3, or VCG4.
	No X, Y, or Z lead ECG data has been recorded.	VCG report printing is impossible.
	X, Y, Z data was recorded in special mode (500 samples/second) on a cardiograph not configured for VCG recording.	Analyze the ECG on a cardiograph that is configured for VCG recording.

# Index

---

- 1 1 ECG(s) Transmitted, C-3
  
- 5 +5 backup supply, 5-21  
+5 overvoltage/undervoltage circuit, 5-19  
+5READY signal, 5-19, 5-26, A-8  
+5-to-backup switchover circuit, 5-21  
+5V, 6-23, A-3, A-8, A-9, A-10  
+5VF, A-11  
+5 volt regulator, 5-2, 5-19  
5VREF, A-3
  
- A A(1)–A(23) signals, A-8  
AC  
  power, 2-2  
  switch, 2-2  
accessories, cardiograph, 1-10–11  
AC indicator, 2-13, 3-3, 5-20, 7-4  
AC on detector circuit, 5-20  
ACONLED signal, 5-20, A-2  
ACON signal, 5-20  
address bus, 5-8  
ADS signal, A-8  
AHA leads, D-2  
**Alt**, 3-3  
alternate main menu, 3-9  
analog-to-digital converter, 5-1, 5-6, B-13  
angular scale, D-7  
Applications display, B-3  
arrow keys **←** **→** **▲** **▼**, 3-3  
AutoCopy parameter, 2-25  
AutoDial  
  configuration, 2-30  
  site selection, 2-30  
Auto report  
  formats, 3-4  
  rhythm lead selection, 3-4  
**Auto**,start control, 3-3

- B** backup +5 supply, 5-21
- battery
  - compartment, 2-11
  - holder, 2-11
  - installation, 2-11
  - operation, 5-18
  - problems, 6-9
  - removing, 7-2
  - replacing, 2-11, 7-4
  - slot, 2-12, 7-4
  - temperature, 5-18
  - timeout, configuring, 2-26
- battery charger, 5-18
  - converter, 5-18
  - current limiting, 5-18
  - cycle output mode, 5-18
  - float output mode, 5-18
- battery condition, 5-18
  - low battery disconnect, 5-19
  - low battery shutdown, 5-18
  - low battery warning, 5-18
- battery connector, 5-18
- battery level indicator, 2-13, 3-3, 5-20, 7-4
- battery sensor, 5-18
- battery switch circuit, 5-20
- battery-to-AC switchover circuit, 5-20
- baud rate, 2-7
- baud rate selection
  - receive, 2-30
  - transmit, 2-28
- block diagram
  - CPU assembly, 5-9
  - digital signal processor, 5-15
  - disk drive, 5-15
  - I/O control, 5-13
  - patient module, 5-7
  - power supply, 5-17
  - preview display, 5-24
  - preview display power supply, 5-27
  - preview logic board, 5-25
  - printer, 5-23
  - SAECG patient module, B-14
  - serial communications circuit, 5-14
  - system, 5-5
  - system memory, 5-11
- brightness knob
  - preview screen, 3-3, 5-27
- BT0, BT1 signals, A-8

- C**
  - cable
    - modem, 2-2
    - printer, 2-4
  - cable options, 1-9
  - cables
    - fax modem, connecting, 2-3
  - calibration pulse
    - amplitude, 4-9
    - duration, 4-9
  - calibration voltage, 5-6, B-13
  - Calling site, C-3
  - cardiograph
    - cleaning, 4-10
    - configuring, 2-17
    - CPU initialization, 5-3
    - description, 1-1
    - installing on cart, 2-2
    - model differences, 1-2
    - operation, 3-1-16
    - operational overview, 5-1
    - options and accessories, 1-9-11
    - password, 2-17
    - specifications, 1-5
  - cardiograph specifications, 1-8
  - cart, 1-3
    - description, 1-3
    - parts list, 8-20
  - changing
    - the date setting, 2-16
    - the line fuses, 2-10
    - the line voltage setting, 2-8
    - the time setting, 2-16
  - CHARGEROFF signal, 5-20
  - CheckDisk, 3-11
  - Choose site, C-3
  - choosing
    - a report format, 3-4
    - language, 2-13
    - the line frequency, 2-13
  - circuit descriptions, 5-4-27
  - cleaning, 4-10-13
    - cardiograph, 4-10
    - electrodes, 4-13
    - keyboard, 4-10
    - leadwires, 4-13
    - paper sensor, 4-11
    - patient data cable, 4-13
    - printhead, 4-11
  - cleaning materials, 4-10, 4-11
  - configuration, 2-17-32
    - AutoDial, 2-30
    - custom lead groups, 2-25
    - global, 2-19, D-10
    - main menu, 2-17
    - menu structure, 2-17

- password, 2-17
- patient ID, 2-27
- printing settings, 2-32
- receive, 2-30
- storing, 2-31
- transmit, 2-28
- Configuration, 2-6
  - Configuration file jobs menu, 2-31
  - configuration parameters
    - AutoCopy, 2-25
    - battery timeout, 2-26
    - custom lead groups, 2-25
    - interpretation, 2-24
    - line frequency, 2-24
    - password, 2-26
    - selecting, 2-19
  - configured software, 5-10
  - Configure Site menu, 2-6, 2-28
  - configuring
    - LaserJet printing, 2-6
  - configuring for VCG recording, D-3
  - Connected to site., C-3
  - connecting cables for printing, 2-4
  - connecting fax modem cables, 2-3
  - connecting the patient module data cable, 2-7, B-2
  - Connection? None, 2-6
  - contrast knob
    - keyboard display, 3-3
    - patient module display, 3-3
    - preview screen, 3-3, 5-27
  - controls
    - keyboard display contrast knob, 3-3
    - patient module display contrast knob, 3-3
    - preview screen brightness knob, 3-3
    - preview screen contrast knob, 3-3
    - remote start button , 3-3
  - controls, front panel, 3-2, 5-22
  - Copy**, 3-3
  - country options, 1-9
  - CPU, 5-8
    - address bus, 5-8
    - data bus, 5-8
  - CPU assembly, 5-8
    - CPU, 5-8
    - data buffers, 5-8
    - digital signal processor, 5-14
    - disk controller, 5-15
    - I/O control, 5-12
    - power supply, 5-16
    - programmable interrupt controller, 5-8
    - removing, 7-29
    - replacing, 7-31
    - ROM, 5-10
    - system expansion connector, 5-8, 5-15
    - system memory, 5-10

- CPU assembly block diagram, 5-9
- CPU assembly test, 4-3
- CPU problems, 6-13
- current limiting, 5-18
- custom 3-lead group, D-10
- custom lead groups parameters, 2-25

**D**

- D(0)–D(15) signals, A-8
- data bus, 5-8
- data cable
  - connecting to patient module, 2-7, B-2
- Data Comm, 2-2
- data communications package
  - parts list, 8-21
- date change display, 2-16
- date, changing the setting, 2-16
- DCD signal, A-7
- DCn signal, A-8
- Defective VCG data, D-11
- delete options, 1-9
- DETECTOR signal, A-4
- dial type, configuring
  - pulse, 2-28
  - tone, 2-28
- digital signal processor, 5-1, 5-14
  - block diagram, 5-15
- Direct Connection, 2-6
- DIRECTION signal, A-10
- disabling VCG reports, D-4
- disassembling
  - the preview screen assembly, 7-13, 7-15
- disassembly
  - tools required, 7-2
- disk
  - reformatting, 3-11
  - storage space available, 3-11
- DISKCHANGE signal, A-10
- disk drive, 5-15
  - block diagram, 5-15
  - problems, 6-16
  - removing, 7-31
  - removing and replacing, 7-31
  - replacing, 7-32
  - test, 4-4
- disk label, 2-31
- display
  - alternate main menu, 3-9
  - Configuration file jobs menu, 2-31
  - configuration menu, 2-17
  - Configure Site menu, 2-28
  - Configure (transmit), 2-28
  - date change, 2-16
  - Extended Self-test, 4-2, B-11, C-5
  - keyboard, 5-22

- main menu, 2-16, 3-4
- parameter selection, 2-19
- time change, 2-16
- Transmit menu, 3-10
- documentation options, 1-10
- DOOR signal, A-4
- DRAM array, 5-10
- DRAM gate array, 5-2, 5-10, 5-19
  - watchdog timer, 5-2
- DRV0SEL signal, A-10
- DRV1SEL signal, A-10
- DRV2SEL signal, A-10
- DRV3SEL signal, A-10
- DSP, 5-14

## E

- ECG
  - receiving, C-4
- ECG data path, 5-1
- ECG management parameters
  - cart ID, 2-26
  - confirmation, 2-26
  - institution name, 2-26
  - location code, 2-26
  - user labels, 2-26
- ECG report format
  - Auto, 3-4
  - Manual, 3-4
- ECGs
  - receiving, C-3
  - transmitting, C-3
- ECG simulation
  - recording, 4-8
- ECG simulator, 4-8, 6-1
  - testing with, 4-8
- ECG size**, 3-3
- electrodes
  - cleaning, 4-13
- EMITTER signal, A-4
- Enter key , 3-3
- error codes, 6-3
- error log, 4-14
  - clearing, 6-2
  - codes, 6-3
  - interpreting, 4-7
  - printing, 4-7
  - sample printout, 6-2
  - using, 6-2
- errors
  - 1499, software error, 6-6
  - power-on, 6-7
  - transmit and modem, 6-20
- excluding patient ID entries, 2-27
- Extended self-test, 4-2, B-11, C-5
- Extended Self-test

- All tests, 4-7
- CPU assembly test, 4-3
- deleting tests, 4-7
- disk drive test, 4-4
- fax modem test, C-6
- keyboard display test, 4-6
- modem test, 4-6
- patient module and cable test, 4-3, B-12
- preview display test, 4-5
- printer test, 4-4
- printing error log, 4-7
- starting, 4-2, B-11, C-5
- stopping, 4-2, B-11, C-5
- subassembly failure messages, 6-4
- test menu, 4-2, B-11, C-5
- using for troubleshooting, 6-4

**F** fax modem

- test, C-6

Fax modem, 2-3

- Fax modem cable, 2-2, 2-3
- Fax Programmable Modem, C-2

FGA, 5-12, 5-22

- baud rate generation, 5-12
- data bus arbitration, 5-12
- enable and select generation, 5-12
- keyboard interface, 5-12
- patient module interface, 5-12
- system clock generation, 5-12

Filter, 3-3Find, C-3flow chart

- CPU initialization, 5-3

format, ECG report

- Auto, 3-4
- Manual, 3-4

formats, D-7

- manual report, D-10

“Foundation” gate array, 5-12FP signal, 5-26, A-11, A-12front panel, 3-2fuse

- changing, 2-10
- rating, 2-10

- G**
  - gain accuracy, checking, 4-8
  - gate array
    - DRAM, 5-2, 5-10, 5-19
    - FGA (“Foundation”), 5-12, 5-22
    - printer, 5-20, 5-22
  - global configuration, 2-19, D-10
  - global parameters, 2-20-26
    - AutoCopy, 2-25
    - battery timeout, 2-26
    - custom lead groups, 2-25
    - ECG management, 2-26
    - interpretation, 2-24
    - line frequency, 2-24
    - password, 2-26
  
- H**
  - HLDA signal, A-8
  - HOLD signal, A-8
  
- I**
  - IBIT0 signal, A-8
  - IBIT2 signal, A-8
  - ID, 3-3
  - IEC leads, D-2
  - INDEX signal, A-10
  - indicator lights
    - AC, 2-13, 3-3, 5-20, 7-4
    - battery level, 2-13, 3-3, 5-20, 7-4
    - low battery, 2-13, 3-3, 5-18
  - initialization flow chart, 5-3
  - inspection, visual, 4-1
  - installation, 2-1-16
  - installing
    - software, 2-13, 2-14
    - the battery, 2-11
    - the cardiograph, 2-1
    - the modem, 2-2
    - the printer drive gears, 7-11
  - INT7 signal, A-8
  - interpretation parameters, 2-24
  - INTR signal, A-8
  - I/O control, 5-12
    - block diagram, 5-13
    - chip select, 5-12
    - FGA, 5-12
    - read enable, 5-12
    - serial communications, 5-14
    - UART, 5-14
    - write enable, 5-12

- K**
  - KBD RESET signal, A-2
  - keyboard, 3-2, 5-12, 5-22
    - cleaning, 4-10
    - problems, 6-20
    - removing, 7-5
  - keyboard display, 5-22
    - contrast knob, 3-3
    - problems, 6-20
    - test, 4-6
  - keys
    - Alt, 3-3
    - arrow keys (←) (→) (↑) (↓), 3-3
    - Auto start, 3-3
    - Copy, 3-3
    - ECG size, 3-3
    - Enter key (↵), 3-3
    - Filter, 3-3
    - ID, 3-3
    - Manual start, 3-3
    - Menu, 3-3
    - On-Standby, 3-3
    - Page Advance, 3-3
    - softkeys, 3-3
    - Speed, 3-3
    - Stop, 3-3
    - V Leads, 3-3
  - KRX signal, A-2
  - KTX signal, A-2
  
- L**
  - LCDDATA signal, A-2
  - LCDE signal, A-2
  - LCDON signal, 5-26, A-8
  - LCDRS signal, A-2, A-8
  - LCDRW signal, A-2, A-8
  - LD0-LD3 signal, A-11
  - LD0-LD3 signals, A-12
  - LD signal, 5-26
  - lead status, patient module, 5-6, B-13
  - leadwires
    - cleaning, 4-13
  - line frequency parameter, 2-24
  - line fuse
    - changing, 2-10
    - location, 2-10
    - rating requirements, 2-10
  - line module, 2-8
    - opening, 2-9
  - line voltage, checking the setting, 2-8
  - loading printer paper, 2-14
  - logic power, 5-19
    - logic power, backup, 5-21
  - look-up table, printer, 5-22
  - low battery
    - disconnect, 5-19

- indicator lights, 3-3
- shutdown, 5-10, 5-18, 5-20
- warning, 5-18
- low battery disconnect circuit, 5-21
- low battery indicator, 2-13, 5-18
- LP signal, 5-26, A-11, A-12
- lubrication, 4-9

**M**

- main assembly parts list, 8-5, 8-9
- main functions, 3-9
- main menu, 2-16, 3-4
- maintenance
  - philosophy, 6-1
  - preventive, 4-9
- Manual report
  - formats, 3-4
  - lead selection, 3-4
- Manual**, start control, 3-3
- menu
  - alternate main, 3-9
  - configuration, 2-17
  - Configuration file jobs, 2-31
  - Configure Site, 2-28
  - Configure (transmit), 2-28
  - Extended Self-test, 4-2, B-11, C-5
  - main, 2-16, 3-4
  - Transmit, 3-10
- Menu**, 3-3, 3-9
- microprocessor, 5-8
- MIO<sub>n</sub> signal, A-8
- modem
  - connection parameter, 2-28
  - installing on cart, 2-2
  - problems, 6-20
  - test, 4-6, C-6
- More, C-3
- motor driver circuit, 5-22
- MOTOR ON signal, A-10
- multiplexors, 5-1

**N**

- nADS signal, A-9
- nBHE signal, A-9
- nBLE signal, A-9
- nCTS signal, A-7
- nDTR signal, A-7
- Next, C-3
- nLATCH signal, A-3
- nLOCK signal, A-9
- NOBATT signal, A-5
- noise, 6-11
- nONKEY signal, A-2
- no VCG report
  - troubleshooting, D-11
- nPSTB signal, A-3

nPVEND signal, A-9  
nRD signal, A-9  
nRDY signal, A-9  
nWAIT signal, A-9  
nWEH signal, A-9  
nWEL signal, A-9

- O** OBIT1 signal, A-9
  - On-Standby, 3-3
  - opening the top cover assembly, 7-17, 7-19
  - options, cardiograph, 1-9-11
    - cable, 1-9
    - country, 1-9
    - delete, 1-9
    - documentation, 1-10
    - substitute, 1-10, 1-13
    - supplies/accessories, 1-10
  - opto-isolators, 5-6, B-13
  - ordering information, parts, 8-1
  - overvoltage monitoring, 5-19

- P** P1-P4 signals, A-4
  - Page Advance, 3-3
  - paper, loading, 2-14
  - paper sensor, cleaning, 4-11
  - paper transport, 5-22
  - parameters
    - AutoCopy, 2-25
    - battery timeout, 2-26
    - custom lead groups, 2-25
    - global, 2-20
    - interpretation, 2-24
    - line frequency, 2-24
    - password, 2-26
  - parameter selection display, 2-19
  - parts list, 8-1-21
    - cart, 8-20
    - data communications package, 8-21
    - main assembly, 8-5, 8-9
    - patient module, 8-3
    - preview display, 8-18
    - printer, 8-15
  - parts ordering information, 8-1
  - password, configuration, 2-17
  - password, setting, 2-26
  - patient data cable
    - cleaning, 4-13
    - connecting, 2-7, B-2
  - patient ID
    - configuration, 2-27
    - excluding entries, 2-27
  - patient module, 5-1, D-2
    - analog-to-digital converter, 5-1, 5-6, B-13
    - block diagram, 5-7

- cable:test, 4-3, B-12
- calibration voltage, 5-6, B-13
- connecting the data cable, 2-7, B-2
- display contrast knob, 3-3
- electrical isolation, 5-6, B-13
- lead status, 5-6, B-13
- leadwires, 4-8
- multiplexors, 5-1, 5-6, B-13
- opto-isolators, 5-6, B-13
- parts list, 8-3
- problems, 6-11
- remote start button, 5-6
- remote start button , 3-3
- SAECG, B-13
- setting up, D-2
- test, 4-3, B-12
- patient module cable
  - test, 4-3, B-12
- patient module voltage (VFE) regulator, 5-21
- patient simulator, 4-8
- pause length, 2-28
- PCLK signal, A-9
- PDOUT signal, A-3
- performance verification, 4-1-9
  - checklist, 4-1, 4-14
  - ECG simulation, 4-8, 4-15
  - Extended Self-test, 4-2, 4-14, B-11, C-5
  - visual inspection, 4-1, 4-14
- phone line connector, 2-3
- phone number, entering, 2-28
- POWERGND, A-11
- power-off sequence, 5-2, 5-10
- power-on
  - problems, 6-7
- power-on application
  - selecting, 2-24
- power-on sequence, 5-2, 5-10
- power supply, 5-16-21
  - +5 backup supply, 5-21
  - +5 overvoltage/undervoltage circuit, 5-19
  - +5-to-backup switchover circuit, 5-21
  - +5 volt regulator, 5-19
  - AC on detector circuit, 5-20
  - battery charger, 5-18
  - battery switch circuit, 5-20
  - battery-to-AC switchover circuit, 5-20
  - block diagram, 5-17
  - low battery disconnect circuit, 5-21
  - patient module voltage (VFE) regulator, 5-21
  - printer switch circuit, 5-20
  - system ready circuit, 5-19
  - tests, 6-22
  - voltage reference circuit, 5-20
- PRCLK signal, A-3
- preventing a VCG report, D-5

- preventive maintenance, 4-9-13
  - cleaning, 4-10
  - lubrication, 4-9
- preview display, 5-24-27
  - assembly block diagram, 5-24
  - logic board, 5-25
  - logic board block diagram, 5-25
  - parts list, 8-18
  - power supply block diagram, 5-27
  - preview screen, 5-27
  - problems, 6-19
  - static RAM, 5-25
- preview display test, 4-5
- preview logic board, 5-25, 6-7
  - block diagram, 5-25
  - removing, 7-25, 7-27
  - replacing, 7-28
- preview screen, 5-27
  - brightness knob, 3-3, 5-27
  - contrast knob, 3-3, 5-27
  - disassembling, 7-13, 7-15
  - fluorescent backlighting, 5-27
  - removing, 7-12, 7-15
  - replacing, 7-17
- Previous, C-3
- printer, 5-22-23
  - analog-to-digital converter, 5-23
  - block diagram, 5-23
  - control circuit, 5-22
  - loading paper, 2-14
  - look-up table, 5-22
  - motor driver, 5-22
  - motor speed, 5-22
  - paper speed, 4-8
  - paper transport, 5-22
  - parts list, 8-15
  - problems, 6-14
  - RAM, 5-22
  - removing the drive assembly, 7-7, 7-9
  - replacing the drive assembly, 7-11
- printer cable, 2-4
- printer door
  - removing, 7-7, 7-9, 7-20, 7-21
- printer drive assembly
  - installing the gears, 7-11
  - removing, 7-7, 7-9
  - replacing, 7-11
- printer gate array, 5-20, 5-22
- printer switch circuit, 5-20
- printer test, 4-4
- printhead, 4-11, 5-22, 5-23, 7-20
  - cleaning, 4-11
  - removing, 7-20, 7-21
  - replacing, 7-23
  - resistance, 5-22

- resistance code, 7-23
- temperature, 5-22
- printhead assembly
  - removing, 7-20, 7-21
- printhead cover
  - removing, 7-9
- printing
  - configuration settings, 2-32
  - connecting cables, 2-4
  - the error log, 4-7
  - VCG, D-4
- printing ECGs
  - on printer, 2-4
- programmable interrupt controller, 5-8

**Q** QRFEDATA signal, A-6  
QRS loops, D-7

**R** RAM refresh, 5-10  
READDATA signal, A-10  
Reading the disk, C-3  
real-time counter (RTC), 5-10  
receive, configuring

- baud rate, 2-30
- connection, 2-30

receiving ECGs, C-4  
recording a simulated ECG, 4-8  
reformatting a disk, 3-11  
reinstalling the top cover assembly, 7-20  
remote start button  $\diamond$ , 3-3, 5-6  
removing

- the battery, 7-2
- the CPU assembly, 7-29
- the disk drive, 7-31
- the keyboard, 7-5
- the preview logic board, 7-25, 7-27
- the preview screen assembly, 7-12, 7-15
- the printer door, 7-7, 7-9, 7-20, 7-21
- the printer drive assembly, 7-7, 7-9
- the printhead, 7-20, 7-21
- the printhead cover, 7-9
- the user interface assembly, 7-5

removing the preview logic board, 7-27  
removing the printhead assembly, 7-20, 7-21  
removing the top cover assembly, 7-18, 7-20  
repair philosophy, 6-1  
replacing

- the battery, 7-4
- the CPU assembly, 7-31
- the disk drive, 7-32
- the preview logic board, 7-28
- the preview screen assembly, 7-17
- the printer drive assembly, 7-11
- the printhead assembly, 7-23

Research leads?, D-10  
reset, processor, 5-2  
reset vector, 5-2  
resistance, printhead, 5-22, 7-23  
    setting the selector, 7-23  
RFELCK signal, A-6  
RFEDATA signal, A-6  
RI signal, A-7  
ROM, 5-10  
routine maintenance, 4-9  
RTS signal, A-7  
RXD signal, A-7

**S** SAECG patient module, **B-13**  
    block diagram, B-14  
safety standards, 4-13  
safety tests, 4-13  
sagittal projection, D-7  
SCP signal, 5-26, A-11, A-12  
Select, C-3  
selecting configuration parameters, 2-19  
serial communications circuit block diagram, 5-14  
setting  
    the date, 2-16  
    the line voltage, 2-8  
    the printhead resistance code, 7-23  
    the time, 2-16  
setting up the patient module, D-2  
SHUTOFF signal, 5-19  
SIDE1SEL signal, A-10  
signal names  
    +5READY, 5-19, 5-26  
    ACON, 5-20  
    ACONLED, 5-20, A-2  
    CHARGEROFF, 5-20  
    FP, 5-26  
    KBD RESET, A-2  
    KRX, A-2  
    KTX, A-2  
    LCDDATA, A-2  
    LCDE, A-2  
    LCDON, 5-26  
    LCDRS, A-2  
    LCDRW, A-2  
    LD, 5-26  
    LP, 5-26  
    nONKEY, A-2  
    SCP, 5-26  
    SHUTOFF, 5-19  
    SWITCHON, 5-20  
    SYSRDY, 5-19  
    UD, 5-26  
    UNITOFF, 5-21  
    UNITON, 5-2, 5-19, 5-21

VBATMEAS, 5-20  
VLCDEN, 5-26  
VREF2, 5-21  
signals  
+5READY, A-8  
A(1)-A(23), A-8  
ADS, A-8  
BT0, BT1, A-8  
D(0)-D(15), A-8  
DCD, A-7  
DCn, A-8  
DETECTOR, A-4  
DIRECTION, A-10  
DISKCHANGE, A-10  
DOOR, A-4  
DRV0SEL, A-10  
DRV1SEL, A-10  
DRV2SEL, A-10  
DRV3SEL, A-10  
EMITTER, A-4  
FP, A-11, A-12  
HLDA, A-8  
HOLD, A-8  
IBIT0, A-8  
IBIT2, A-8  
INDEX, A-10  
INT7, A-8  
INTR, A-8  
LCDON, A-8  
LCDRS, A-8  
LCDRW, A-8  
LD0-LD3, A-11, A-12  
LP, A-11, A-12  
MIO<sub>n</sub>, A-8  
MOTOR ON, A-10  
nADS, A-9  
nBHE, A-9  
nBLE, A-9  
nCTS, A-7  
nDTR, A-7  
nLATCH, A-3  
nLOCK, A-9  
NOBATT, A-5  
nPSTB, A-3  
nPVENd, A-9  
nRD, A-9  
nRDY, A-9  
nWAIT, A-9  
nWEH, A-9  
nWEL, A-9  
OBIT1, A-9  
P1-P4, A-4  
PCLK, A-9  
PDOUT, A-3  
PRCLK, A-3

QRFEDATA, A-6  
 READDATA, A-10  
 RFECLK, A-6  
 RFEDATA, A-6  
 RI, A-7  
 RTS, A-7  
 RXD, A-7  
 SCP, A-11, A-12  
 SIDE1SEL, A-10  
 STEP, A-10  
 THERM+, A-5  
 THERM-, A-5  
 TRK00, A-10  
 TURBO, A-9  
 TXD, A-7  
 UD0-UD3, A-11, A-12  
 VLCDEN, A-11  
 WRITEDATA, A-10  
 WRITEGATE, A-10  
 WRITEPROTECT, A-11  
 WRn, A-9  
 simulator, ECG, 4-8, 6-1  
   testing with, 4-8  
 site  
   AutoDial, 2-30  
   transmit, 2-28  
 site number, 2-6  
 softkeys, 3-3  
   All, 3-10  
   AM/PM, 2-16  
   AutoDial, 2-28, 2-30  
   CheckDisk, 3-9  
   Choose, 2-19  
   Clear, 2-16  
   Config, 2-17, 3-9  
   Enter, 2-16, 2-19  
   ErrorLog, 4-2, B-11, C-5  
   Exit, 2-16, 2-18, 2-19, 2-28, 2-31, 3-9, 3-10  
   Files, 2-18, 3-9  
   Format, 3-4  
   Global, 2-18, 2-20, 3-9  
   ID, 2-18, 2-27, 3-9  
   Leads, 2-19, 3-4  
   NewGroup, 3-10  
   Next, 4-2, B-11, C-5  
   Pause(), 2-29  
   Previous, 2-19, 4-2, B-11, C-5  
   Print, 2-18, 2-31, 3-9  
   Query, 3-10  
   Receive, 2-28, 2-30  
   Report, 3-4  
   Select, 4-2, 4-7, B-11, C-5  
   Selected, 3-10  
   Store, 2-31, 3-9  
   Tab, 2-19

- Test, 4-2, 4-7, B-11, C-5
- Tone(W), 2-29
- Transmit, 2-18, 2-28, 3-9
- software
  - installing, 2-13, 2-14
  - storing, 2-31
- software error 1499, 6-6
- Special applications, D-10
- specification, 1-5
- specifications, 1-8
  - ECG to paper, 1-6
  - environmental, 1-7
  - miscellaneous, 1-8
  - patient module, 1-5
  - physical, 1-5
  - power supply and battery, 1-6
  - SAECG patient module, 1-5
- Speed**, 3-3
- speed accuracy, checking, 4-8
- standard accessories, 1-10
- standard patient module, 5-6
- standards
  - safety, 4-13
- STEP signal, A-10
- Stop**, 3-3, C-4
- storing configuration, 2-31
  - disk label, 2-31
- storing the software, 2-31
- subassemblies, removable, 7-1
- substitute options, 1-10, 1-13
- supplies/accessories options, 1-10
- SWITCHON signal, 5-20
- SYSRDY signal, 5-19
- system block diagram, 5-5
- system expansion connector, 5-15
- system I/O, 5-12
- system memory, 5-10
  - block diagram, 5-11
  - DRAM array, 5-10
  - power supply support, 5-10
  - RAM refresh, 5-10
  - real-time counter, 5-10
  - watchdog timer, 5-10
- system RAM, 5-1

**T**

- telecommunications package, 1-4
  - description, 1-4
- temperature, printhead, 5-22
- test equipment, required, 6-1
- test pattern
  - keyboard display, 4-6
  - patient module display, 4-3, B-12
  - preview display, 4-5
  - printer, 4-4

- tests
  - CPU assembly, 4-3
  - deleting, 4-7
  - disk drive, 4-4
  - fax modem, C-6
  - keyboard display, 4-6
  - modem, 4-6, C-6
  - patient module, 4-3, B-12
  - patient module cable, 4-3, B-12
  - power supply, 6-22
  - preview display, 4-5
  - printer, 4-4
  - safety, 4-13
  - starting, 4-3
- theory of operation, 5-1-27
- thermal printhead, 5-23
- THERM- signal, A-5
- THERM+ signal, A-5
- time change display, 2-16
- time, changing the setting, 2-16
- tools for disassembly, 7-2
- top cover assembly, 7-17
  - opening, 7-17, 7-19
  - reinstallation, 7-20
  - removing, 7-18, 7-20
- transmit
  - problems, 6-20
- Transmit, 2-6, C-3
- transmit configuration, 2-28
- transmit, configuring
  - baud rate, 2-28
  - connection, 2-28
  - dial type, 2-28
  - pause length, 2-28
  - phone number, 2-28
- Transmit menu display, 3-10
- transmit site, 2-28
  - phone number, 2-28
- transmitting
  - ECGs, C-4
  - via fax, C-3
- Transmitting 1 of 1 ECG(s), C-3
- transmitting ECGs, C-3
- Transmitting ... , C-3
- TRK00 signal, A-10
- troubleshooting, 6-1-24, D-10
  - Defective VCG data, D-11
  - Extended Self-test, using, 6-4
  - noise problems, 6-11
  - no VCG, D-11
- troubleshooting tables, 6-5-21, C-7
  - CPU assembly, 6-13
  - disk drive, 6-16
  - flowchart, 6-6
  - keyboard and keyboard display, 6-20

- patient module and cable, 6-11
- power supply and battery, 6-9
- preview display and logic, 6-19
- printer, 6-14
- transmit and modem, 6-20
- TURBO signal, A-9
- TXD signal, A-7

**U**

- UART, 5-14
- UD0-UD3 signals, A-11, A-12
- UD signal, 5-26
- undervoltage monitoring, 5-19
- UNITOFF signal, 5-21
- UNITON signal, 5-2, 5-19, 5-21
- upgrade kits, 1-11
- user interface assembly, removing, 7-5

**V**

- V3R, V4R, V7, D-10
- VBACK, 5-21, 6-22
- VBACK7, A-9
- VBAT, 5-18, 5-20, 6-22
- VBAT+, A-5
- VBATMEAS signal, 5-20
- VBAT-, A-5
- VCC, 5-26
- VCCFILT, A-12
- VCFL, 5-27
- VCFL1, 2, A-12
- VCFLRET, A-12
- VCG
  - printing, D-4
  - report formats, D-7
- vCG?, D-11
- VCG1, D-7
- VCG2, D-7
- VCG3, D-7, D-8
- VCG4, D-7, D-8
- VCG recording
  - configuration, D-3
- VCG report, D-6
  - disabling, D-4
  - preventing from printing, D-5
- VFE, 5-21, 6-23, A-6
- VFE regulator, 5-21
- VIN, 5-16, 5-20, 5-26, 6-22, A-9, A-11
- visual inspection, 4-1
- VLCD, 5-27, A-12
- VLCD, A-2
- VLCDEN signal, 5-26, A-11
- V Leads, 3-3
- VMAIN, 5-16
- voltage reference circuit, 5-20
- voltage regulator
  - +5 volt, 5-2, 5-19

VFE (patient module), 5-21  
voltages  
+5V, 6-23, A-3, A-8, A-9, A-10  
+5VF, A-11  
5VREF, A-3  
POWERGND, A-11  
power supply, 6-22  
VBACK, 5-21, 6-22  
VBACK7, A-9  
VBAT, 5-20, 6-22  
VBAT+, A-5  
VBATMEAS, 5-20  
VBAT-, A-5  
VCC, 5-26  
VCCFILT, A-12  
VCFL, 5-26  
VCFL1, 2, A-12  
VCFLRET, A-12  
VFE, 5-21, 6-23, A-6  
VIN, 5-16, 5-19, 5-20, 5-26, 6-22, A-9, A-11  
VLCD, 5-26, A-2, A-12  
VMAIN, 5-16  
VPRINT, 5-20, 6-23, A-4, A-5  
VREF25, 5-20  
VTHERM, A-3  
voltage test locations, 6-23  
VPRINT, 6-23, A-4, A-5  
VREF2 signal, 5-21  
VTHERM, A-3  
VX1, VX2, VX3, VX4, D-10

**W** watchdog timer, 5-2, 5-10  
WRITEDATA signal, A-10  
WRITEGATE signal, A-10  
WRITEPROTECT signal, A-11  
WRn signal, A-9

