

Biox 3700/3700e Pulse Oximeter

Service Manual

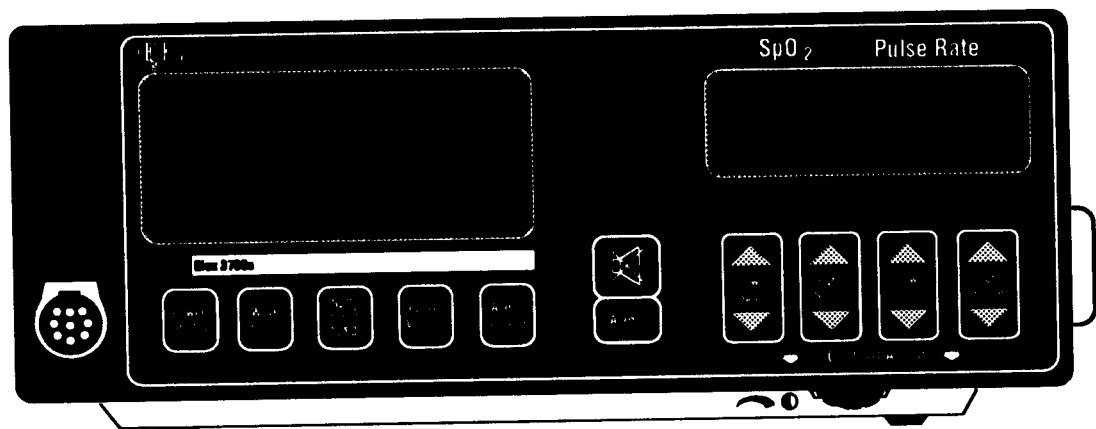
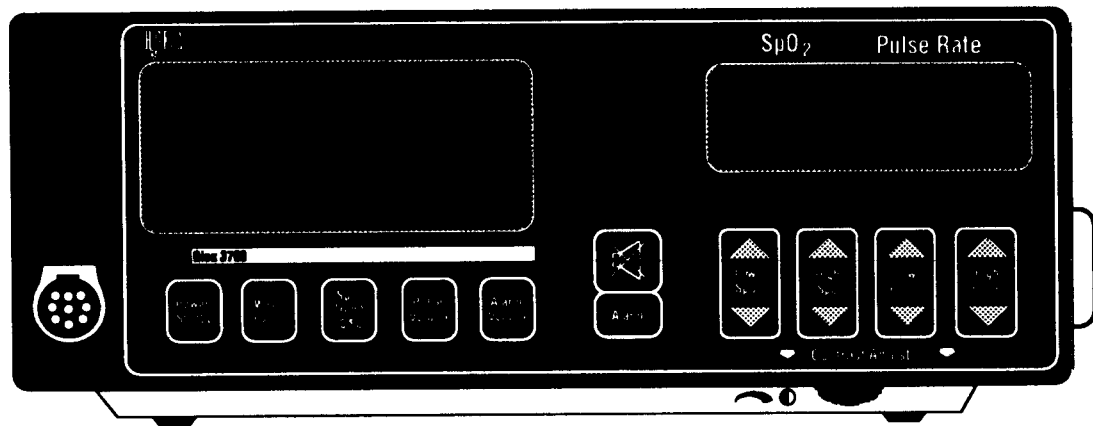

OHMEDA
L&SP

Handwritten signature

THE BOC GROUP

Biox 3700/3700e Pulse Oximeter

Service Manual

Important

This manual is subject to periodic review, update, and revision. Customers are cautioned to verify that the manual's information applies to the software and hardware present in the equipment.

This product performs as described in this manual, and in accompanying labels and/or inserts, when assembled, operated, maintained, and repaired in accordance with the instructions provided.

This product must be cleaned and checked periodically. Do not use a defective product. Parts that are broken, missing, plainly worn, distorted, or contaminated should be replaced immediately. If repair or replacement become necessary, call or write to request service advice from the nearest Ohmeda Regional Service Center (listed on the back cover). Do not repair this product or any of its parts other than in accordance with written instructions provided by Ohmeda and by Ohmeda-trained personnel.

The product must not be altered without the prior written approval of Ohmeda's Safety Department. The user of this product shall have the sole responsibility for any malfunction that results from improper use, faulty maintenance, improper repair, unauthorized service, damage, or alteration by anyone other than Ohmeda.

The safety, reliability, and performance of this device can only be assured under the following conditions:

- If the device has been used according to the accompanying operating instructions.
- If fittings, extensions, readjustments, changes, or repairs have been carried out by Ohmeda's authorized agents.
- If it is used in buildings that have ground equalization wiring that complies with relevant IEC or local standards and regulations (ETL, UL, CSA, PSI, TUV, etc.).

Ohmeda is a registered trademark of Ohmeda, Inc.

Text revised June, 1994

© 1988, 1994 Ohmeda, Inc.
All rights reserved.

Table of Contents	i
List of Illustrations	v
1/Overview	
1.1 General description	1-1
1.2 Specifications	1-2
1.2.1 Physical	1-2
1.2.2 Accuracy	1-2
1.2.3 Alarm limits	1-3
1.2.4 Default settings	1-3
1.2.5 Audible alarms	1-3
1.2.6 Environmental	1-4
1.2.7 Electrical	1-4
1.3 Precautions	1-6
1.3.1 Warnings	1-6
1.3.2 Cautions	1-8
1.4 Safety procedures	1-10
1.4.1 Cleaning the monitor	1-10
2/Theory of Operation	
2.1 Block interconnect diagram	2-2
2.2 Front panel diagram	2-3
2.3 Rear panel diagram	2-4
2.4 Interconnect cables diagram	2-5
2.5 Power supply board	2-6
AC power conversion	2-6
Battery charging circuit	2-6
On/Off circuit	2-6
2.5.1 Power regulating circuits	2-7
RAM standby circuit	2-7
Positive 5-volt circuit	2-7
Positive V circuit	2-7
Negative V and positive/negative -15 V	2-7
Power fail circuit	2-7
Low battery detection circuit	2-8
Electroluminescent (EL) panel driver	2-8
Line frequency detector circuit	2-8
2.6 Digital board	2-9
Crystal oscillator	2-9
Power ON reset	2-9
Watchdog timer	2-9
Microprocessor	2-9
Address latch	2-10
Interrupt latch	2-10
ROM	2-10
Data RAM	2-10
Address decoding	2-10
Serial communication port	2-12
Input and output ports	2-12
Analog outputs	2-14
Audio output	2-14

Table of Contents

2.7	Front panel assembly.....	2-15
	Graphic display/graphic module interface.....	2-15
	Display board.....	2-15
	Membrane switch panel.....	2-16
2.8	Analog board.....	2-16
	Probes.....	2-16
	Timing control.....	2-16
	Reference voltages.....	2-17
	LED drive.....	2-17
	LED drive monitor.....	2-18
	Photodetector preamplifier.....	2-18
	Calibration test signal.....	2-18
	Ambient light cancellation.....	2-19
	DC gain.....	2-19
	DC separator.....	2-20
	Low-pass filter.....	2-20
	DC stripper (high-pass filter).....	2-20
	AC gain.....	2-20
	Red/infrared separator.....	2-21
	Calibration.....	2-21
	Sample and hold.....	2-21
	Probe identification.....	2-21
	Analog multiplexer.....	2-21
	A/D converter.....	2-21
	Interference detection.....	2-21
	Audio frequency control.....	2-22
	Audio volume control.....	2-22
3/Test and Calibration		
3.1	Functionality test.....	3-1
3.2	User calibration mode.....	3-3
3.3	Diagnostics mode procedures.....	3-4
3.3.1	SpO ₂ and pulse rate analog outputs.....	3-5
3.3.2	Calibration test.....	3-6
3.3.3	ROM test.....	3-6
3.3.4	Power source frequency test.....	3-6
3.3.5	Digital interface circuit test.....	3-7
3.3.6	Graphic display test.....	3-7
3.3.7	Digital display test.....	3-8
3.3.8	Speaker pitch test.....	3-8
3.3.9	Speaker volume test.....	3-8
3.3.10	SpO ₂ D/A converter ramp test.....	3-9
3.3.11	Pulse rate and LED D/A converter ramp test.....	3-9
3.3.12	DC gain, AC gain, and A/D converter tests.....	3-10
3.3.13	R/IR ratio/phase test.....	3-10
3.3.14	Probe identification test.....	3-11
3.3.15	RAM test.....	3-11
3.3.16	Watchdog timer test.....	3-12
3.4	Leakage current and ground resistance test.....	3-12

4/Messages and Troubleshooting

4.1 Messages4-1
 4.2 Troubleshooting4-7
 Diagnostics troubleshooting.....4-7
 System troubleshooting.....4-8

5/Repair Procedures

5.1 Service and repair policy5-2
 5.1.1 Obtaining technical assistance and service.....5-2
 5.1.2 Packaging and return procedure.....5-2
 5.2 Frequently used procedures.....5-4
 5.2.1 Removing the cover5-4
 5.2.2 Removing the front panel.....5-4
 5.2.3 Replacing the front panel.....5-5
 5.2.4 Installing the cover5-5
 5.3 Remove and replace procedures.....5-7
 5.3.1 Front panel5-7
 5.3.2 Board set.....5-8
 5.3.3 Probe connector.....5-9
 5.3.4 Battery5-10
 5.3.5 Software5-11
 5.4 Adjusting the battery charging circuit5-13
 5.5 Adjusting the display contrast.....5-14
 5.6 Measuring the power supply5-14
 5.7 Oximeter assembly information5-16
 5.7.1 Oximeter assembly illustration.....5-16
 5.7.2 Interface board connections—close view5-17
 5.7.3 Reference designators5-18

6/Parts and Illustrations

6.1 Oximeter assembly.....6-2
 6.1.1 Oximeter assembly illustration.....6-2
 6.1.2 Oximeter assembly parts list.....6-2
 6.1.3 Oximeter assembly service kits.....6-4
 6.2 Front panel assembly.....6-5
 6.2.1 Front panel assembly illustration.....6-5
 6.2.2 Front panel assembly parts list.....6-6
 6.3 Rear panel assembly6-7
 6.3.1 3700 rear panel assembly illustration6-7
 6.3.2 3700e rear panel assembly illustration6-8
 6.3.3 3700 rear panel assembly parts list6-9
 6.3.4 3700e rear panel assembly parts list6-9
 6.4 Analog board assembly.....6-10
 6.4.1 Analog board assembly diagram.....6-10
 6.4.2 Analog board reference designators.....6-10
 6.4.3 Analog board schematic.....6-13
 6.5 Digital board.....6-14
 6.5.1 Digital board diagram.....6-14
 6.5.2 Digital board reference designators.....6-14
 6.5.3 Digital board schematic6-16

Table of Contents

6.6	Display board assembly	6-17
6.6.1	Display board diagram	6-17
6.6.2	Display board reference designators	6-17
6.6.3	Display board schematic	6-19
6.6.4	Membrane panel switch schematic	6-20
6.7	Power supply board	6-21
6.7.1	Power supply board diagram	6-21
6.7.2	Power supply board reference designators	6-21
6.7.3	Power supply board schematic	6-24
6.8	Interface board	6-25
6.8.1	Interface board diagram	6-25
6.8.2	Interface board reference designators	6-25
6.8.3	Interface board schematic	6-26

Section	Description	Page
2.1	Block interconnect diagram	2-2
2.2	Front panel diagram	2-3
2.3	Rear panel diagram	2-4
2.4	Interconnect cables diagram	2-5
4.2	Diagnostics troubleshooting chart	4-7
	System troubleshooting chart	4-8
5.7.1	Oximeter assembly illustration	5-16
5.7.2	Interface board connections—close view	5-17
6.1.1	Oximeter assembly illustration	6-2
6.2.1	Front panel assembly illustration	6-5
6.3.1	3700 rear panel assembly illustration	6-7
6.3.2	3700e rear panel assembly illustration	6-8
6.4.1	Analog board assembly diagram	6-10
6.4.3	Analog board schematic	6-13
6.5.1	Digital board diagram	6-14
6.5.3	Digital board schematic	6-16
6.6.1	Display board diagram	6-17
6.6.3	Display board schematic	6-19
	6.6.4 Membrane panel switch schematic	6-20
	6.7.1 Power supply board diagram	6-21
	6.7.3 Power supply board schematic	6-34
	6.8.1 Interface board diagram	6-25
	6.8.3 Interface board schematic	6-26

1/Overview

This manual provides instructions for servicing the Ohmeda Biox 3700 or 3700e Pulse Oximeter, Revision M and above. This chapter contains:

- A general description of the oximeter.
- Oximeter specifications and options.
- Precautions, including specific warnings and cautions, you must follow when servicing the monitor.
- Safety procedures you must follow when handling equipment that may be contaminated and when making repairs.

1.1 General Description

The Ohmeda Biox 3700 or 3700e Pulse Oximeter is a stand-alone, noninvasive, arterial oxygen saturation monitor. Ear, finger, and flex probes connect the monitor to the patient, giving continuous oxygen saturation (SpO₂) and pulse rate readings.

The oximeter measures a patient's arterial oxygen saturation and pulse rate by measuring the absorption of selected wavelengths of light. The light generated in the probe passes through the tissue and is converted into an electronic signal by the probe's photodetector. The electronic signal passes to the oximeter and is amplified. Analog and digital signal processing convert the light intensity information into SpO₂ values. Two liquid crystal displays (LCDs) present patient data and status information. The digital LCD shows the patient's SpO₂ and pulse rate and the graphic LCD shows the plethysmographic waveform trend data, and status and alarm messages.

Note: For a detailed description of the unit's components, key functions, general operating guidelines, chart recorder connection, and computer interface, see the *Ohmeda Biox 3700/3700e Pulse Oximeter Operator's Manual*. For information on probe or sensor application and cleaning see the instructions for the appropriate probe or sensor.

1.2 Specifications

Unless otherwise indicated, all specifications are nominal and are subject to change without notice.

1.2.1 Physical

Dimensions

Height: 10.16 cm (4.0 in)
Width: 25.40 cm (10.0 in)
Depth: 28.70 cm (11.3 in)
Weight: 3.86 kg (8.5 lb)

Front panel

Display: Seven-segment liquid crystal display (LCD) and dot matrix LCD
Probe connector: Hypertac 9-pin, injection-molded polycarbonate

Rear panel connectors

Analog output: 1/8" mini phone jack
Digital output: 25-pin "D" socket
Ground equalization: DIN 42-801

Fuses

100V/120V: Dual 5x20mm T 0.25A / 250V
220V/240V: Dual 5x20mm T 0.25A / 250V

Power input connector

IEC 320: 125 V, 15 A
250 V, 6 A

1.2.2 Accuracy

SpO₂

Range: 0 to 100%

Range	Accuracy (1 Standard Deviation)	Data points
90 to 100%	1.5%	183
80 to 89.9%	2.1%	197
60 to 100%	2.4%	616
Below 59.9%	unspecified	

Accuracy measurements are statistically derived and correlated to simultaneous arterial blood gases measured on an IL-282 co-oximeter.

Pulse Rate

Range: 40 to 235 BPM
Display Range: 0 to 255 BPM
Accuracy: $\pm 1.7\%$ of current reading (assuming a constant pulse rate)

1.2.3 Alarm Limits

SpO₂ alarm limit range

High = 70 to 100%,
Low = 50 to 100%.

Pulse rate alarm limit range in beats per minute (BPM):

High = 70 to 250 BPM
Low = 40 to 200 BPM
0 (zero) to 255 BPM will display; 0-20 BPM will appear as dashes; above 235 BPM, the data may be invalid

1.2.4 Default settings

Parameter	Default Setting	Range
High SpO ₂ Limit	OFF (appears as: - - -)	70% to 100%
Low SpO ₂ Limit	85% (90% at software revision 22 or lower)	50% to 100%
High Pulse Rate	OFF (appears as: - - -)	70 to 250 BPM*
Low Pulse Rate	OFF (appears as: - - -) (50 BPM at software revision 22 or lower)	40 to 200 BPM
Alarm Volume	4	1 to 10
Pulse Volume	4	OFF to 10
Response Time	S N at software revision 22 or lower)	S, N, F
Alarm Filter	ON	OFF, ON

* BPM = Beats-Per-Minute

1.2.5 Audible alarms

Setting levels available:

SpO₂ - 1 through 10

Pulse - Off through 10

Frequency = 400 to 800 Hertz

Intensity at 1-meter distance:

Volume setting of 1: 55 decibels (minimum)

Volume setting of 10: 75 decibels (maximum)

1.2.6 Environmental

Temperature

Operating Range: 0° to 50°C (32° to 122°F)

Storage Range: -20° to 60°C (-4° to 140°F)

Note: At temperature extremes, the liquid crystal display may show reduced contrast, ghosting, or darkening. When returning from temperature extremes, allow the oximeter temperature to stabilize before use.

International Electrotechnical Commission classifications

Type of protection against electric shock: Class I/Internal electrical power source

Degree of protection against electric shock: Type BF

Degree of protection against ingress of liquids: Ordinary

Mode of operation: Continuous

Recommended methods of sterilization or disinfection: See section 1.4.1 in this manual and the instructions for the probe you are using for recommended procedures for cleaning this equipment.

Degree of safety of application in the presence of a flammable anesthetic mixed with air or with oxygen or nitrous oxide: Equipment not suitable for use in the presence of a flammable anesthetic mixture with air or with oxygen or nitrous oxide.

1.2.7 Electrical

General

Input voltage (minimum and maximum) for stable operation:

Range	Operation
90 to 110 V	100 V
108 to 132V	120 V
198 to 242 V	220 V
216 to 264 V	240 V

Current: Normal draw, approximately 0.2 A at 100/120 V or 0.1 A at 220/240 V

Power: 100, 120, 220, 240 V (single phase)

Frequency: Limits = 47 to 63 Hz

Patient isolation from power input:

20 MW, 2500 V RMS at 60 Hz (EarProbe, FingerProbe, and Flex II probe to third wire ground)

Chassis breakdown voltage: 1500 V RMS at 60 Hz

Ground resistance: <0.1 Ω

Leakage current, forward and reverse polarity: 50 μA maximum

Battery

1, 4-cell pack

Sealed lead-acid

Operation time: 1.5 hours typical with all functions operating

Recharging time: 80% capacity = approx. 4 hours.

100% capacity = approx. 16 hours

Voltage: 8 V, 2.5 amp-hours

Charge life: several hundred charge/discharge cycles

Constant voltage charger: 9.35 to 9.40 V

Power cord

Type: 16 AWG, 3-conductor jacketed, SJT gray, 10 feet

Voltage and current rating: 6 A, 250 V or 15 A, 125 V

Power consumption (25 watts typical)

	Output	SpO ₂	Pulse rate
Analog	Voltage	0V/1V = 0% - 100%	0V/1V = 0-250 BPM
	Impedance	300 Ω	300 Ω
Digital	Voltage	RS-232C compatible	
	Impedance	RS-232C compatible	

Analog Output

Current: 3 milliamperes (at full scale output)

Connector type: 1/8" miniature phone jack

Mating Connector Plug: 1/8" miniature phone plug

Connector polarity: tip = signal (+); sleeve = ground (-)

Serial Output

Number of bits per character: 7

Parity: odd

Number of stop bits: 1

Connector type: 25-pin standard D, female

Connector pin functions:

1 = chassis ground

2 = receive data by the oximeter

3 = transmit data from the oximeter

7 = signal ground

Probes and sensors

Refer to the instructions for the probe or sensor you are using.

1.3 Precautions

Two types of precautions appear in this manual: warnings and cautions.

1.3.1 Warnings

A **WARNING** indicates the possibility of injury to the patient or operator.

Handle the monitor with care. Improper handling can cause damage or inaccurate results.

Failure of operation

If the oximeter fails any part of the preoperative checkout procedures, calibration, or current leakage test, remove it from operation until qualified service personnel have corrected the situation.

The oximeter is a microprocessor-based device designed to immediately shut down if the microprocessor fails. This prevents the possible display of erroneous information. No alarms forewarn this action.

Data validity

Calibration is verified during powerup. Do **not** operate the oximeter unless it is properly calibrated or inaccurate patient readings will result.

Excessive ambient light, excessive motion, low perfusion, or electrical interference at the probe site may cause erroneous readings.

To prevent erroneous readings, do not use an inflated blood pressure cuff on the same limb as the oximeter probe.

To prevent inaccurate patient readings, the digital voltmeter used in reference voltage test procedures must be accurately calibrated.

On units with software revision 23 or higher, the low quality signal indicator no longer appears. It is strongly recommended that the user monitor the plethysmographic waveform and signal strength indicator to make the determination that the data being presented are valid.

Electrical shock and flammability hazard

To protect against fire hazard, replace only with fuses of the same type and local line voltage rating.

Disconnect the power supply from the unit before starting fuse replacement.

Explosion hazard

Do not use the oximeter in the presence of flammable anesthetics or other flammable substances.

Electrical shock hazard

This equipment must be properly grounded.

- Connect this equipment only to a three-wire, grounded, hospital-grade receptacle. The three-connector plug must be inserted into a properly wired three-wire receptacle; if a three-wire receptacle is not available, a qualified electrician must install one in accordance with the governing electrical code.
- Do not under any circumstances remove the grounding connector from the power plug.
- Do not use extension cords or adapters of any type. The power cord and plug must be intact and undamaged.
- If there is any doubt about the integrity of the protective earth conductor arrangement, operate the monitor on internal battery power until the AC mains protective conductor is fully operational.

To prevent injury,

- Before servicing or cleaning the monitor, turn the unit off and disconnect the power cord from the AC power supply.
- Do not touch any exposed wiring or conductive surface while the cover is removed. The voltage present when electrical power is connected to the monitor can cause serious injury or death.
- Never wear a grounding wrist strap when working on an energized oximeter.

Measure the oximeter's leakage current whenever an external device is connected to either the analog or serial port. Leakage current must not exceed 50 microamperes.

Because the unit is not grounded when it is operated on battery power, do not connect any equipment to the signal input/output ports on the rear panel unless the unit is connected to the AC mains power supply.

Battery replacement

Unauthorized personnel should not attempt to install, connect, or replace the oximeter's battery.

- Removing the cover and/or faulty battery connections could be hazardous and will void the warranty.
- Reversing the battery connections could result in injury and will permanently damage the circuitry.
- If trained technical personnel are not available, call Ohmeda for assistance.
- For proper operation, replace only with an Ohmeda battery.
- To prevent failure of the 2 amp fuse on the power supply board, do not cross battery connections

Patient safety

Do not, under any circumstances, perform any testing or maintenance on the oximeter or probe when it is being used to monitor a patient.

To prevent patient injury or equipment damage, use only oximeter probes identified for this monitor (see the instructions for the probe you are using).

If a probe is damaged in any way, discontinue use immediately.

Prolonged monitoring or patient condition may require periodically changing the probe test site. To reduce the risk of blistering, skin erosion, or ischemic skin necrosis, change the probe site as specified in the user instructions for the probe you are using. If any evidence of the above conditions appears prior to the specified time period (for example, discoloration or reddening), change the probe site immediately.

To avoid any possibility of patient discomfort or injury during magnetic resonance imaging,

- Do not allow the oximeter probe cable to come in contact with the patient's body; keep the cable off of the patient or place a blanket or other insulating material between the patient and the probe cable.
- Position the oximeter probe and probe cable as far from the center of the magnetic field as possible.

The correct use of the oximeter is to measure only arterial oxygen saturation (SpO₂) and pulse rate.

- A pulse oximeter does not measure respiration and under no circumstances should be used as a substitute for an apnea monitor.
- The oximeter must not be used as the primary monitor for infants being monitored for apnea, either in the hospital or in the home setting. It measure SpO₂ and pulse rate, and only in conjunction with other appropriate monitoring techniques.
- A pulse oximeter is often used during sleep studies with adults, but must be used only to gather information regarding SpO₂ and pulse rate during these studies.
- A pulse oximeter is to be used only by or on the order of medically trained personnel.

Refer to the instructions for the probe or sensor you are using for detailed warning information.

1.3.2 Cautions

A **CAUTION** indicates a condition that may lead to equipment damage or malfunction.

Federal law in the U.S.A. and Canada restricts the sale of this device by or on the order of a licensed medical practitioner.

Always make sure the monitor is set up to operate at the AC power supply voltage present at the "wall" receptacle.

Avoid storing the oximeter and probes at temperatures below -20°C (-4°F) or above 60°C (140°F).

To prevent damage to the lead-acid battery, do not turn the monitor on after the Recharge Battery alert message appears without first plugging it into the AC power supply.

To prevent improper loading, which upsets the correspondence between the measured voltage and the intended output voltage, connect only a high impedance device ($1\text{K}\ \Omega$ or higher) to the analog output.

Static sensitivity

The oximeter's electronic components are susceptible to damage by electrostatic discharge. When disassembling the unit,

- Work at a static-control workstation and wear a static-control wrist strap to discharge accumulated static charges from you and any tool you use.
- Use nonconductive tools.
- Handle circuit boards (replacement and defective) by their nonconductive edges. Use anti-static containers to transport them.

Detailed information for more extensive repairs is included in the service manual solely for the convenience of users having proper knowledge, tools, and test equipment, and for service representatives trained by Ohmeda.

Refer to the instructions for the probe or sensor you are using for detailed caution information.

Cleaning

- Do not autoclave, pressure sterilize, or gas sterilize this oximeter.
- Do not soak or immerse the monitor in any liquid.
- Use the cleaning solution sparingly. Excessive solution can flow into the monitor and cause damage to internal components.
- Do not touch, press, or rub the display panel with abrasive cleaning compounds, instruments, brushes, rough-surface materials, or bring it into contact with anything that could scratch the panel. Do not use petroleum-based or acetone solutions, or other harsh solvents to clean the display panel.

1.4 Safety procedures

WARNINGS:

Patient safety—Do not, under any circumstances, perform any testing or maintenance on the oximeter or probe when it is being used to monitor a patient.

Electrical shock hazard—Before cleaning or repairing the oximeter, always turn it off and unplug it from the AC power supply.

Read and follow each step of all test and repair procedures to ensure their proper and safe completion. Give special attention to all WARNINGS and CAUTIONS.

Before you start any procedure that involves disassembly of the oximeter, be sure to

- Power off and disconnect the unit for the AC power supply.
- Clean the unit--see section 1.4.1.
- Disconnect the probe from the unit.

After repairs are complete,

- Test the unit as directed in each procedure to verify that it is functioning properly.
- Complete the "Preoperative checklist" in 2/Operations in the *Ohmeda Biox 3700/3700e Operator's Manual*.

1.4.1 Cleaning the monitor

You must clean the oximeter,

- Before you start any test or repair procedure that involves disassembly of the monitor.
- Before you send it to Ohmeda for repair.

Equipment

- Safety eyeglasses or face guard.
- Disposable latex-based gloves.
- Paper towels.
- Cool, liquid cleansing agent, such as 70% isopropyl alcohol or equivalent.

CAUTION: Cleaning

- Do not autoclave, pressure sterilize, or gas sterilize this oximeter.
- Do not soak or immerse the monitor in any liquid.
- Use the cleaning solution sparingly. Excessive solution can flow into the monitor and cause damage to internal components.
- Do not touch, press, or rub the display panel with abrasive cleaning compounds, instruments, brushes, rough-surface materials, or bring it into contact with anything that could scratch the panel. Do not use petroleum-based or acetone solutions, or other harsh solvents to clean the display panel.

To clean the oximeter,

1. Wash your hands before you handle the unit.
2. Wear safety eyeglasses and disposable latex gloves.
3. Disconnect the probe from the unit.
4. Spray a solution of cool, liquid cleansing agent on a paper towel and use it to wipe the surface of the unit.
5. Let the oximeter stand for 3 minutes, then dampen a clean paper towel with water and wipe the surface of the unit.

Note: Wait for the oximeter's surface to dry before handling.

6. Discard the used paper towels and gloves as you would potentially contaminated waste materials.
7. Wash your hands.

2/Theory of Operation

This chapter provides the

- Block interconnect diagram
- Front panel diagram
- Rear panel diagram
- Interconnect cables diagram
- Theory of operation for the
 - Power supply board
 - Digital board
 - Display board
 - Analog board

This chapter supplies basic circuitry information and is not intended to be an exact representation of the product.

The reference designators used in these circuit theories are found in 6/Illustrated Parts List.

Note: All resistors are ¼ Watt 5% unless otherwise noted.

2.2 Front panel diagram

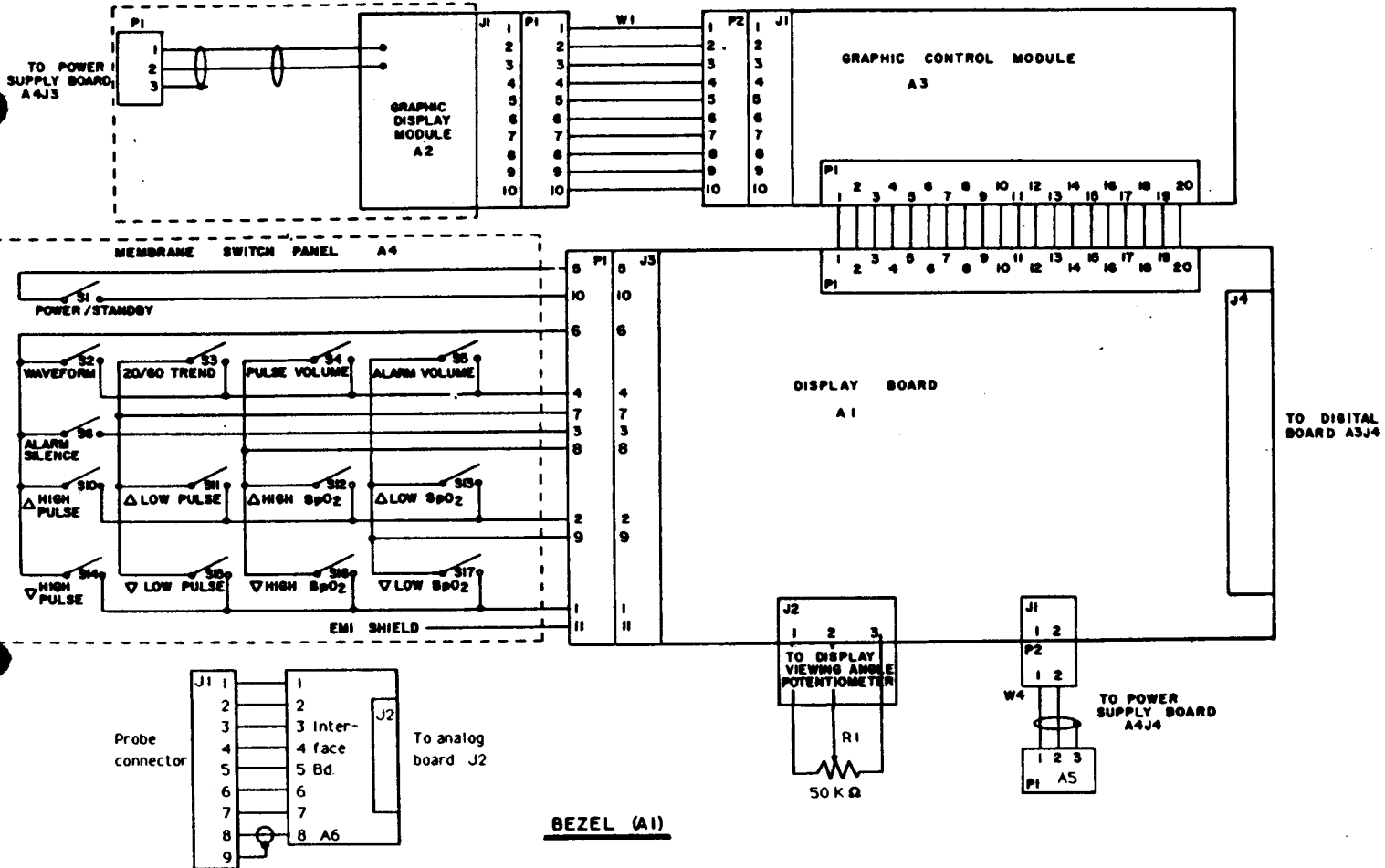

2.3 Rear panel diagram

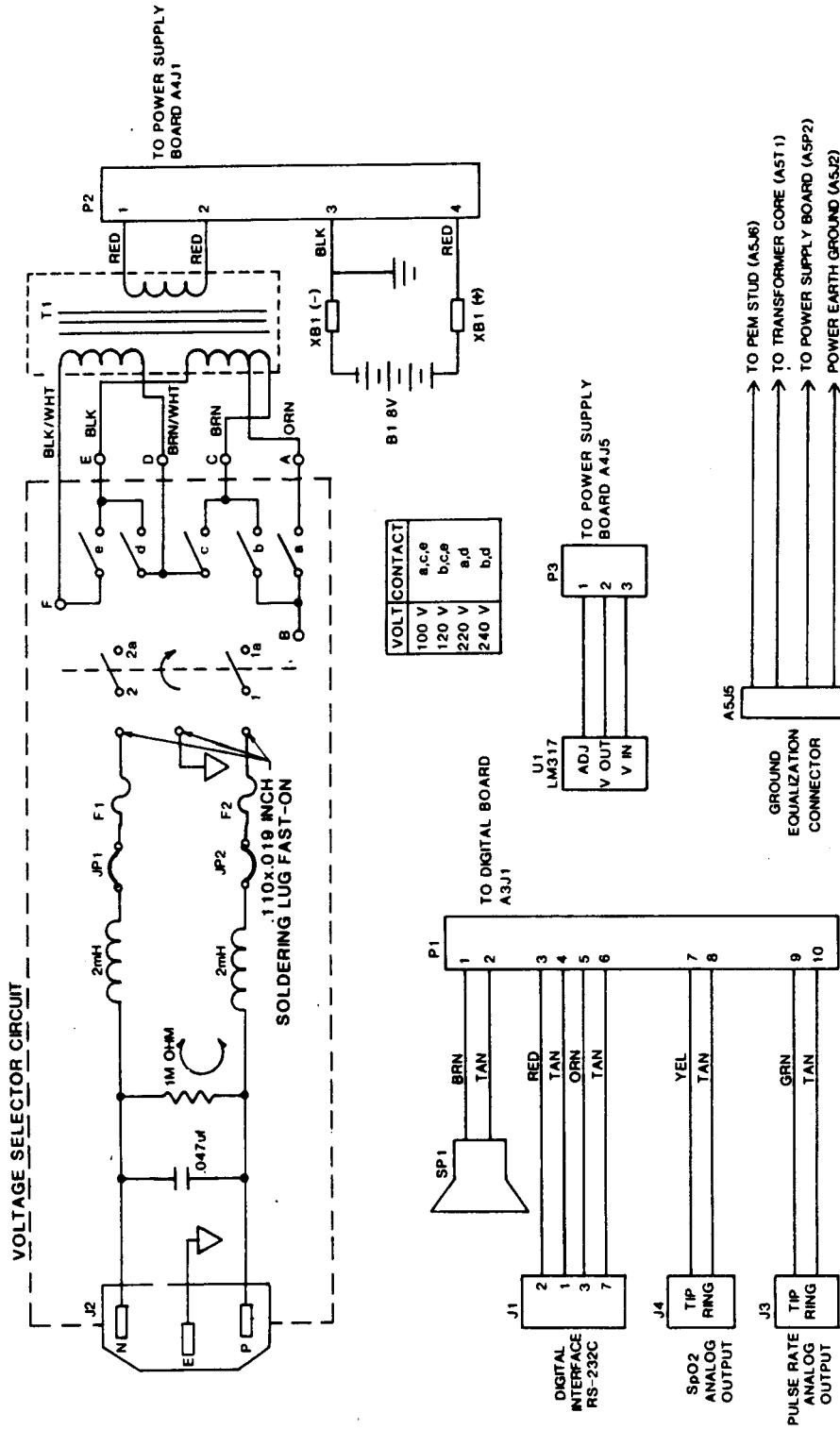

2.4 Interconnect cables diagram

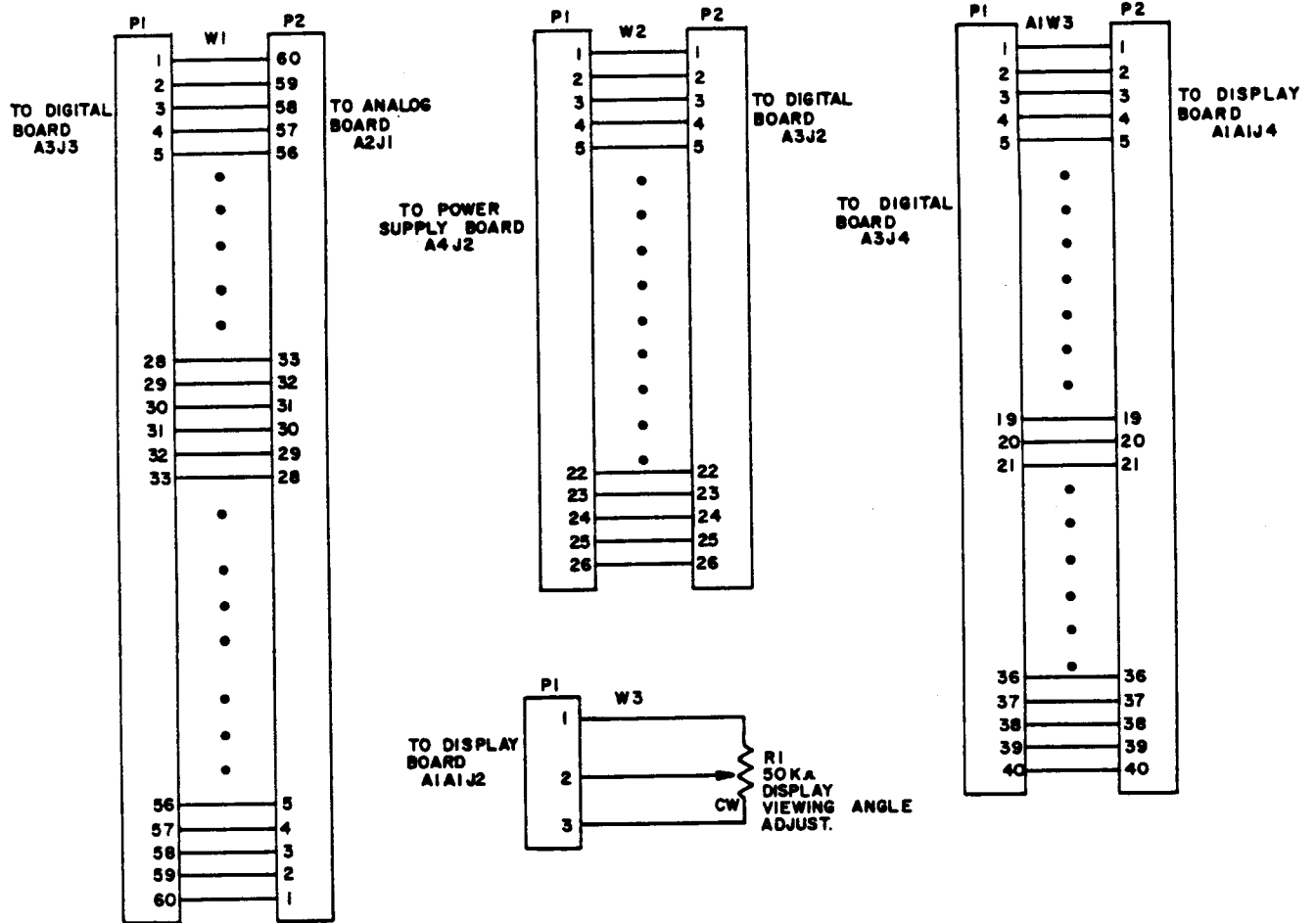

2.5 Power supply board

AC power conversion

When the oximeter is plugged into AC power and the Power/Standby switch is in the On position, the output from the transformer is rectified by a full wave bridge rectifier (CR1), smoothed by filter capacitors C1 and C2, and regulated by a 3-terminal regulator (connected to J5). This power passes through Schottky blocking diode CR11 to operate the unit.

Battery charging circuit

The same regulator that supplies power to the unit is also used to charge the battery. Resistors R3 and R4 and potentiometer R5 set the output voltage of the regulator. The power to charge the battery passes through a current limiting resistor (R27) and a Schottky blocking diode (CR12).

The battery-charging voltage is set for 9.35 to 9.40 volts.

Three Schottky diodes (CR10, CR11, CR12) set up the blocking of current so the battery charges while the unit is operating. When the unit is not plugged in, the relay (K1) shorts out one diode (CR10). This guarantees that the unit has enough overhead voltage from the battery to drive the regulators (U12, U13, U15, U16, U17).

On/Off circuit

The battery or battery-charging circuit supplies power to the power on/off control circuit and the RAM standby regulator through diode CR18.

When the oximeter is turned on, the initial surge of current to charge capacitances on the boards causes a sudden drop in the supply voltage at the cathode of CR11. CR18 and capacitor C4 prevent this spike from affecting the power on/off control circuit.

The power on/off control circuit operates in one of two different modes (3700 or 3710) depending on the position of switch SW1.

In 3700 mode, power to the unit is controlled by a single momentary contact switch (Power/Standby), which toggles power on and off. If SW1 is erroneously placed in the 3710 position in a 3700 or 3700e oximeter, the Power/Standby key has no function. Connecting the 3700 or 3700e oximeter to AC power turns it on and disconnecting it turns it off, but it will not operate on battery power.

With SW1 in the 3700 position, U18-2 is held low, which causes the SET input of flip-flop U9B to be held low. J2-12 (COM/OFF) is also held low and serves as the common return for the Power/Standby switch. Resistor R46 pulls U18-8 high, which disables this input as a reset to flip-flop U9B.

Pressing the Power/Standby switch momentarily grounds J2-10 (PWR/STBY). During the power on sequence the power sensing circuit (transistors Q3 and Q4 and resistors R30 and R29) keeps the RAM

disable signal (RAM DIS-) low until the +5V power supply voltage is above the turn on threshold of Q3, which is high enough to enable the RAM without losing information.

Pressing Power/Stndby a second time toggles U9B and starts the following sequence of operations:

- The Q output of U9B goes low, causing the inverter output (U8-6) to go high. This signal (OFF) informs the microprocessor that power is being turned off, allowing time to clean up the RAM and turn the unit off. Also, as the Q- output of U9B goes high, a fail-safe timer starts. The fail-safe timer consists of capacitor C9, resistor R9, diode CR7 and gate U7C. If the microprocessor fails to do so, this circuit turns the unit off by generating a reset pulse to U9A approximately 130 milliseconds after U9-12 goes high.
- The microprocessor turns the unit off by ceasing to reset the watchdog timer on the digital board. The signal SHUTDOWN goes high (Q2-GATE), which resets flip-flop U9A and de-energizes the relay K2.

2.5.1 Power regulating circuits

RAM standby circuit

The micro power regulator (U6) supplies power to the RAM while the unit is off. Resistors R6 and R7 set the output voltage of U6 to 4 volts, which passes through the diode (CR5) to the RAM. The RAM sees approximately 3.4 volts; it needs only 2.4 volts to retain its contents.

Positive 5-volt circuit

When the power turns on, relay K2 connects the battery voltage to the regulator circuits U12, U13, U15, J16, and U17. U12 supplies +5 volts to the digital board and supplies 5 volts to Schottky diode (CR9), which supplies power to the RAM on the digital board.

Positive V circuit

Regulator (U13) provides +5 volts for the analog circuitry.

Negative V and positive/negative -15 V

The switching regulators U15, U16, and U17 generate -5 volts for the analog circuitry, and 15 volts for the D/A converter and bugger amplifier on the analog board.

Power fail circuit

Comparators U11-C and U11-D detect when one of the four analog supplies (+V, -V, +15V, or -15V) fails. If one of these voltages drops below half of its normal voltage, the power fail signal goes low. The processor detects this signal and displays a POWER SUPPLY FAILURE message momentarily and automatically turns the oximeter off.

Low battery detection circuit

Comparators U11A and U11B sense the state of discharge of the battery. Reference diode U10 provides an accurate reference for the comparators. Resistor-divider network R21, R16, and R20 sets the voltage levels for the comparators to determine the battery's condition.

Comparator U11B senses when the battery voltage drops below 7.3 volts. The output of this comparator (U11-2, LOW BATT) informs the microprocessor that the charge on the battery is getting low. The unit then displays the LO BT message.

Comparator U11A senses when the battery voltage drops below 7.0 volts. The output of this comparator (U11-1, RECHG) informs the microprocessor that the battery is fully discharged. The unit then replaces the waveform display with the RECHARGE BATTERY message for 15 seconds and then cycles itself off.

CAUTION: To prevent damage to the lead-acid battery, do not turn the monitor on after the RECHARGE BATTERY alert message appears without first plugging it into the AC power supply.

Electroluminescent (EL) panel driver

The following description applies to display board 6050-0003-302, or higher:

This version of the display board has an LED backlight that is powered off of +5V. It does not require a cable connection to J2.

The following description applies to display board A118-004, Rev V, or lower:

A counter circuit synchronizes the EL panel driver to the system clock. The 3.6864 MHz clock feeds counter (U14). The Q13 output of U14 (450 Hz) drives transistor Q6, which drives the transformer T1. This transformer converts 5 volts to approximately 120 volts AC, which powers the EL panels.

The circuit consisting of Q5, R32, R34, C22, C28, and CR15 acts as a fail-safe circuit to protect Q6 and T1. As long as the 3.6864 MHz clock is functioning, it is coupled through capacitor C28 to the gate of Q5. This turns Q5 on and discharges capacitor C22.

If the 3.6864 MHz clock stops functioning, resistor R34 pulls the gate of Q5 low, which turns Q5 off. This allows capacitor C22 to charge to +5 volts through resistor R32, which resets counter U14.

Line frequency detector circuit

15 volts AC from the power transformer goes to resistor R1 and an optoisolator (U1). This puts out a line frequency signal referenced to circuit ground. This signal goes through Schmitt trigger U2A and then to 2 flip-flops (U3A, U3B), a gate (U2B), and an inverter (U8A). This circuit generates a single pulse 4.34 microseconds wide, synchronized to the

power line, which feed the reset on the counter circuit (U5, U4). The counters U4 and U5 have a 3.6864 MHz clock and are reset periodically based on the power line frequency.

The output is coded into 2 bits (FREQ 0 and FREQ 1). The diode, resistor, and capacitor networks (CR8-R11-C8 and CR6-R10-C7) act as retriggerable one shots that go high with a pulse at U4-3 or U4-5 and stay high as long as pulses occur more often than approximately every.1 second. If the power line frequency is greater than 225 Hz (e.g., 400 Hz), the counter is always reset before the first bit of the second stage (U4-3) gets set. This gives a code at FREQ 0, FREQ 1 of 00.

If the power line frequency is between 56 Hz and 225 Hz (e.g., 60 Hz), then U4-3 gets set once every 4 to 18 milliseconds, but U4-5 never gets set. This gives a code at FREQ 0, FREQ 1 of 10.

If the power line frequency is between 19 Hz and 56 Hz (e.g., 50 Hz), then U4-3 and U4-5 both get set. This gives a code at FREQ 0, FREQ 1 of 11.

If the power line frequency is zero Hz (e.g., operating on battery power), the counter is never reset. This allows the counter outputs U4-6 and U4-5 to get set, and feed back through gates U2D and U2C to disable the second stage of the counter. At the time that the counter is disabled, the output U4-3 is low. This gives a code at FREQ 0, FREQ 1 of 01.

2.6 Digital board

Crystal oscillator

The master clock for the oximeter is generated by the crystal oscillator circuit, U27A, Y1, R10, C19, and C20, which oscillates at 3.6864 MHz.

Power ON reset

The circuit C1, R1, CR1, U1A, U1B, and U1C generates a reset signal at power up, holding the processor reset until the power supply voltages stabilize. The reset signal is also sent to the watchdog timer, the interrupt latch, and the serial communication interface.

Watchdog timer

The circuit U4, U2B, U3C, C2, R2, and R3 is a fail-safe timer circuit that turns the oximeter power off if the microprocessor fails. The analog board generates a signal (WCLK, J3-16), which clocks counter U4. The frequency of WCLK is 960 Hz when operating the oximeter for 60 Hz power and 800 Hz when operating the oximeter from 50 Hz power. The microprocessor sets and clears bit 2 on the output port U11-17, to reset U4. This signal is AC coupled to the counter U4 through C2 and U3C. Resistor R2 sets the ground reference for the input (pin 10) to U3, and R3 provides current limiting for the input protection diode inside U3-10. If U4 is not reset before the counter output Q7-4 goes high, then flip-flop U2B gets set and the signal SHUTDOWN is sent to the power supply board, causing the oximeter power to be turned off. Upon powerup, the power on reset circuit resets counter U4 and flip-flop U2B.

Microprocessor

The master controller is a Z8002 microprocessor (U6) with a 16-bit, multiplexed address/data bus. The microprocessor performs all control functions in the oximeter and calculates SpO₂ and pulse rate.

Address latch

U7 and U16 make up the address latch, which demultiplexes the address from the address/data bus. The address strobe (AS) from the microprocessor (U6 pin 26) clocks the address into the latch. Inverter U23A inverts the AS to the correct sense for use by the address latch.

Interrupt latch

Flip-flop U2A latches the nonvectored interrupt (NVI) from the analog board until the microprocessor acknowledges its occurrence, at which time it resets the interrupt latch by clearing and then setting bit 3 of output latch U11-16. Upon powerup, the power on reset circuit resets the interrupt latch. The two resets are or'ed by gate U1D.

ROM

The read-only memory (ROM), U9 and U18, contains the master program for controlling the oximeter and calculating SpO₂ and pulse rate.

Data RAM

Random-access memory (RAM), U8 and U17, stores SpO₂ and pulse rate trend data, system flags, and other data.

Address decoding

Decoders U22 and U28 and gates U3A and U3B perform decoding of memory addresses for ROM and RAM.

U22 decodes byte-word instructions and enables the appropriate half of U28, which in turn enables the appropriate half of the 16-bit-wide memory. When a memory request (MREQ) occurs, U28 enables either ROM or RAM. If address bit 15 is low, ROM is enabled; if address bit 15 is high, RAM is enabled.

Gates U3A and U3B disable RAM (U8 and U17) when address bit 14 is high.

The ROM address space is from hexadecimal (hex) memory address 0000 to 7FFF.

RAM is divided into two section : RAM and memory-mapped input/output (I/O). RAM address space is from hex address 8000 to BFFF. Memory-mapped I/O address space is from hex address C000 to C01D.

U30 and U31 decode the addressing for the memory-mapped I/O. Memory-mapped I/O addresses with pin numbers for U30 and U31 and a brief description are as follows:

Hex address	IC and pin #	Function
C000	U31 - 15	Input data from serial interface
C003	U31 - 14	Output control of AC and DC gain, test mode, and sample frequency
C008	U31 - 13	Input A/D converter data, output A/D control
C00C	U31 - 12	Output alarm light, interrupt reset, watchdog reset, DAR
C010	U31 - 11	Output analog multiplexer control and keyboard scan
C014	U31 - 10	Output Red LED intensity
C018	U31 - 9	Output IR LED intensity
C01C	U31 - 7	Output data to serial interface
C001	U30 - 15	Output to D/A converter for analog pulse rate
C005	U30 - 14	Input keyboard scan, line frequency, A/D status and data valid
C009	U30 - 13	Unused
C00D	U30 - 12	Output SpO ₂ display data
C011	U30 - 11	Output pulse rate
C015	U30 - 10	Output SpO ₂ and pulse rate display control
C019	U30 - 9	Unused
C01D	U30 - 7	Input serial interface status

Decoder U29 performs address decoding for nonmemory-mapped I/O. The I/O addresses with pin numbers for U29 and a brief description are as follows:

Hex address	IC and pin #	Function
0	U29 - 15	Output to D/A converter for analog SpO ₂
3/13	U29 - 14	Output data/control to graphic display
5	U29 - 13	Output audio frequency data
7	U29 - 12	Input power supply status
9	U29 - 11	Unused
B	U29 - 10	Unused
D	U29 - 9	Output audio volume data
F	U29 - 7	Unused

Serial communication port

This port is an RS-232C-compatible interface consisting of the UART (U10), a baud-rate generator circuit (U25, U24D, and U32A), a line-receiver circuit (R4, R5, R7, CR2, and Q1), and a line-driver circuit (U5, R6, and C12).

The baud-rate generator counts the 3.6864 MHz system clock (U25-10) down to 19.2 kHz at U32-5, which is 16 times the serial interface baud rate of 1200.

The line-receiver circuit translates the RS-232C signal (which has a voltage swing range of ± 3 volts to ± 12 volts) to a logic-level signal, which feeds into the UART (U10-20).

The line-driver circuit translates the logic-level signal from the UART (U10-25) into a RS-232C-compatible signal level, which swings ± 5 volts.

The microprocessor controls the UART and memory-mapped I/O. the microprocessor reads the UART status at hex memory address C01D, outputs UART transmit data at hex memory address C01C, and reads input data received by the UART at hex memory address C000. The microprocessor acknowledges received data by clearing and then setting bit 1 of memory-mapped output port U11-18, which is at hex memory address C00C.

Input and output ports

U11, U19, and U26 are memory-mapped output ports that perform the following functions:

U11 hex address C00C

Bit	Pin #	Function
0	19	Unused
1	18	DAR data acknowledge reset to UART
2	17	Watchdog timer reset
3	16	Interrupt latch reset
4	15	Alarm LED control
5	14	Unused
6	13	Unused
7	12	Unused

U19 hex address C004

Bit	Pin #	Function
0	19	FREQ OUT; controls sampling frequency on analog board
1	18	TEST; controls test signal for self-test mode
2	17	A—
3	16	B— Controls AC gain on analog board
4	15	C—
5	14	A—
6	13	B— Controls DC gain on analog board
7	12	C—

U26 hex address C010

Bit	Pin #	Function
0	19	A—
1	18	B— Controls analog multiplexer input
2	17	C— to A/D converter on analog board
3	16	D—
4	15	A—
5	14	B— Output drive
6	13	C— for scanning keyboard
7	12	D—

U20 hex address C005 (memory-mapped input port)

Bit	Pin #	Function
0	2	FREQ 1 along with FREQ 0—power line frequency
1	3	ADSTS A/D converter status input
2	4	DATVAL data valid signal from analog board
3	5	FREQ 0 along with FREQ 1—power line frequency
4	6	A—
5	7	B— Inputs for
6	8	C— scanning keyboard
7	9	D—

U12 hex I/O address 7 (nonmemory-mapped input port)

Bit	Pin #	Function
0	2	Unused
1	3	Unused
2	4	Unused
3	5	Unused
4	6	PWRFAIL—power supply failure
5	7	OFF—unit is being turned off
6	8	RCHG—battery should be recharged
7	9	D—

Analog outputs

The SpO₂ analog output circuit consists of a 10-bit D/A converter (U21), an output amplifier (U15) with a short-circuit protection resistor (R8), a high-frequency roll-off capacitor (C14), and an input-protection diode (CR5). CR3 and CR6 protect U21 from latch-up failure during powerup.

U21, a multiplying D/A converter, multiplies the reference input voltage (-VRED, pin 3) by $-n/1024$, where n is the decimal equivalent of the 10-bit binary number loaded into the holding register inside U21 at hex I/O address 0.

The SpO₂ analog output is set to 1.00 volt full scale, representing 100% saturation.

The heart rate analog output circuit consists of an 8-bit D/A converter (U13), an output amplifier (U14) with a short-circuit protection resistor (R9), a high-frequency roll-off capacitor (C13), and an input-protection diode (CR4). U13, a multiplying D/A converter, multiplies the reference input voltage (-VREF, pin 15) by $-n/256$, where n is the decimal equivalent of the 8-bit binary number loaded into the holding register inside U13 at hex memory address C001.

The full-scale output voltage of 1.00 volt represents a heart rate of 250 beats per minute.

Audio output

The audio output amplifier (U33) is a current buffer amplifier with unity voltage gain. The input to U33 is AC coupled through capacitor C22 and the output is AC coupled through capacitor C28. This output drives an 8- Ω speaker mounted inside the oximeter bottom case.

2.7 Front panel assembly

The front panel assembly contains the graphic display, the graphic module interface, the display board, and the membrane switch panel.

Graphic display/graphic module interface

The graphic display and the graphic module interface connect through a 10-conductor ribbon cable and operate as a unit. The graphic module interfaced to the microprocessor at hex I/O address 3 for data and 13 for control.

Display board

This board provides the interface connections from the digital board (J4) to the membrane switch panel (J3) and to the graphics module interface (P1). It contains the numeric display (DSP1) and the visible alarm indicator (DSP2) with associated circuitry.

The numeric display is an 18-digit triplexed liquid crystal display (LCD). The LCD contains 6 large digits (.5 inch high): 3 each to display SpO₂ and pulse rate, and 12 small digits (.18 inch high), 3 each to display alarm limits for low SpO₂, high SpO₂, low pulse rate, and high pulse rate.

Display drivers (U1 and U2) control the multiplex timing and voltage levels driving the display. U1 controls the 9 digits associated with the pulse rate, and U2 controls the 9 digits associated with SpO₂. The microprocessor writes data into the display driver holding registers at hex memory address C00D for the pulse rate display driver. When the microprocessor writes to hex memory address C015, the display driver holding register data is transferred to the appropriate data register and decoder in both display drivers.

The display drive voltages, which control the viewing angle of both the graphic and numeric displays, are generated by dual operational amplifier U3, resistors R1 and R2, and potentiometers R3 and display contrast adjust (located under the right side of the front panel). The display contrast adjust potentiometer (R5, W3R1) controls both of the display drive voltages. R3 serves as a balance control, affecting only the display drive voltage for the graphic display.

The visual alarm indicator is a red light emitting diode (LED) light bar (DSP2) with three LEDs. Bit 4 of output port U11, located on the digital board, controls field effect transistor (FET) Q1, which turns on the indicator. Resistors R4 and R6 set the current flowing through the LEDs in the indicator.

Membrane switch panel

This panel consists of the Power/Standby switch, with two separate connections (power/standby and com) and 13 other front panel switches arranged in a 4 x 4 matrix (SWOA - SWOD and SWIA - SWID), as follows:

	SWOA	SWOB	SWOC	SWOD
SWI D	Waveform	Alarm silence	▲ High pulse	▼ High pulse
SWI C	SpO ₂ Trend 20/60	unused	▲ Low pulse	▼ Low pulse
SWI B	Pulse volume	unused	▲ High SpO ₂	▼ High SpO ₂
SWI A	Alarm volume	unused	▲ Low SpO ₂	▼ Low SpO ₂

The membrane switch panel also contains a conductive layer for shielding against electromagnetic interference (EMI) and electrostatic discharge (ESD).

2.8 Analog board

Probes/sensors

The probe contains a red LED, and infrared LED, a silicon photodetector, and a resistor that identifies the relationship between the wavelengths of the red and infrared LED.

Timing control

The frequency divider circuit, consisting of counters U5 and U6 and multiplexer U8, controls the frequency of the timing control for the analog circuitry.

When the unit is operating on 60 Hz power, the microprocessor sets FREQ OUT (U8-10 and U11) low. This selects the Q3 output of U5 (U5-7) to pass through switch A of U8 to the reset input of U5 (U5-15), and selects the Q5 output of U6-1 to pass through switch B of U8 to reset input of U6 (U6-15), which sets U5 to divide by 3 and U6 to divide by 5.

The frequency divider circuit therefor divides the 3.6864 MHz input clock (U5-14) by 15 to produce an output clock frequency of 245.76 kHz at U6-2.

When the unit is operating on 50 Hz power, the microprocessor sets FREQ OUT high, which sets U5 to divide by 2 and U6 to divide by 9. In this case, the frequency divider circuit divides the input clock by 18 to produce an output clock frequency of 204.8 kHz.

The master timing information for controlling the analog circuitry is contained in a ROM (U10). Counter U9 accepts the output clock from U6-2 and sequentially addresses the ROM to access the timing

information. The output clock from U6-2 loads the timing information from the ROM into data register U11, which prevents extraneous transitions of the ROM outputs from being propagated through to the analog circuitry.

Reference voltages

Reference diode U36 generates a stable reference voltage of 1.235 volts. Resistor R56 sets the bias current for U36. Dual amplifier U35 uses the stable reference voltage from U36 to generate two stable reference voltages of -1 volt (-VREF, U35-1) and +1 volt (+VREF, U35-7).

Resistors R55 and R51 and potentiometer R52 set the gain of amplified U35A, and R52 adjusts the output to -1 volt. Precision resistors R53 and R54 set the gain of amplifier U35B to -1 volt, which produces an output voltage of +1 volt.

LED drive

The circuitry that provides the drive current for the probe LEDs consists of U25, U27B, Q4, R48, and associated circuitry for driving the red LED, and U19, U27A, Q3, R22, and associated circuitry for driving the infrared LED.

The microprocessor loads an 8-bit binary decimal equivalent of the 8-bit number into the holding register within the multiplying D/A converter U26 to set the drive current for the red LED. Amplifier U27B converts the current output of U19 into a voltage at the emitter of transistor Q4. This voltage appears across resistor R48, which sets a constant current drawn through the collector of Q4 and the red LED in the probe.

The current through the red LED is determined by the relationship:

$$I_{LED} = \frac{V_{REF}}{R48} \times \frac{N}{256}$$

where $V_{REF} = 1$ volt, $R48 = 8.25 \Omega$, and N is the binary number that the microprocessor loads into U26.

The maximum drive current for the red LED is set when $N = 255$. This current is 120 milliamperes, or 40 milliamperes when driving a SoftProbe or Easy Probe. **Note:** The addition of the upgrade interface board restricts the current of either of these probe to a maximum of 45 milliamperes should a failure of software or hardware occur elsewhere within the unit.

Switch A of multiplexer U32 turns the red LED drive on and off. The timing signal from U11-13 controls the switch. The duty cycle of this timing signal is approximately $\frac{1}{3}$.

The infrared LED is controlled in the same manner as the red LED. The maximum drive current for the infrared LED is 60 milliamperes. The timing signal from U11-15 controls switch B of multiplexer U32 to turn the infrared LED on and off. The duty cycle of this timing signal is also approximately $\frac{1}{3}$. The timing of the two LED drive signals is such that each LED is turned on for $\frac{1}{3}$ of the time and they are both off for $\frac{1}{3}$ of the time.

LED drive monitor

Switch C of U32 samples the voltage at the cathode of the red LED when it is on (controlled by signal RLT at U32-9). Capacitor C40 stores this voltage for measurement by the A/D converter U12. Switch A of U33 and capacitor C41 sample the voltage at the cathode of the red LED when it is off (controlled by signal IRLT at U33-11). Similarly, switches B and C of U33 and capacitors C38 and C39 sample the voltages at the cathode of the infrared LED when it is on and off.

Photodetector preamplifier

Amplifier U39, with feedback resistor R66, generates a voltage from the current produced by the photodiode in the probe. This signal passes through switch C of multiplexer U38.

Calibration test signal

Multiplexer U38 controls the selection of the calibration test signal to be injected into the signal path. Amplifiers U25A and U25D, and associated circuitry, generate a 3 Hz sine wave at U25-1. Amplifier 25A, with input resistor R18 and feedback capacitor C23, is an integrator. The output of the integrator feeds back to its input through a two-pole, low-pass, active filter consisting of R14, C24, R13, C22, and U25B. Resistor R17 and diodes CR5 and CR6 limit the voltage swing of the signal fed back through the low-pass filter.

Amplifier U25B and multiplexer U38 accept the 3 Hz sine wave and generate a test signal that simulates the output of the photodetector preamplifier.

The reference voltage (+VREF) feeds input resistor R19 to produce a DC voltage at the output of amplifier U25B-7. The 3 Hz oscillator U25-1 feeds input resistor R15, which adds about .75% modulation to the output of amplifier U25B.

When the signal IR (U38-11) goes high, switch A of multiplexer U38 places resistor R11 in parallel with input resistor R15. This increases the amplitude of the modulation on the output of amplifier U25B to 1.5%.

When the red and infrared diodes are on, switch B of multiplexer U38 passes the output of amplifier U25B through to the Y input of switch C (U38-3). When the signal DK (U38-10) goes high, switch B of U38 selects ground to be passed through the Y input of switch C.

This calibration signal emulates a photodetector preamplifier output that represents a known oxygen saturation and a pulse rate of 150 to 210 beats per minute. The microprocessor checks the calibration of the oximeter by setting the signal TEST (U38-9) high. This selects the calibration signal to be passed through switch C of multiplexer U38 in place of the photodetector preamplifier output.

The signal from U38 pin 4 passes through a switched low-pass filter consisting of resistor R69; capacitors C66, C67, and C68; multiplexer U41; and amplifier U40. This filter is essentially three separate single-pole filters that are time multiplexed into the same signal path. Resistor R69 is a part of all three filters. Switch C of multiplexer U41 selects capacitor C67 to filter during the dark time (control signal DK at U41-9). Switch A of U41 selects capacitor C68 to filter during the red light time (red LED is on, control signal RLT at U41-11). Switch B of U41 selects capacitor C66 to filter during the infrared light time (infrared LED is on, control signal IRLT at U41-10).

With the multiplexing timing considered, the filter has an equivalent pole at approximately 10 Hz, which serves to suppress high-frequency interference that comes in through the photodetector preamplifier. Amplifier U40 acts as a buffer to prevent loading of the filter.

Ambient light cancellation

Capacitor C55 and switch A of multiplexer U30 remove the effects of ambient light from the photodetector signal. Resistor R77 adds offset to the photodetector and assists in ambient light rejection. When the signal DK goes high, switch A of U30 connects one end of C55 to ground. This causes capacitor C55 to charge to the difference between ground and the voltage level of the input signal (U40-6) during the dark time (when both LEDs are off). When the signal DK goes low, the voltage across C55 is subtracted from the input signal as it passes through C55 to the input of amplifier U37.

DC gain

Under microprocessor control, analog multiplexer U34 selects one of the seven resistors (R57 through R63) or an open circuit (U34-13) to combine with feedback resistor R39 to set the gain of amplifier U37. The nominal gains selectable are:

Input number	Input control			Nominal gain
	A	B	C	
0	0	0	0	1
1	0	0	1	2
2	0	1	0	3
3	0	1	1	5
4	1	0	0	9
5	1	0	1	17
6	1	1	0	33
7	1	1	1	66

DC separator

When signal RLT at U31-11 goes high, switch A of U31 passes the red component of the signal from U37 through to the low-pass filter consisting of R75 and C29. The equivalent pole of this switched filter is at approximately 0.4 Hz, which passes only the DC component of the signal. Amplifier U17 passes the red DC signal (RDC) to the multiplexer U13-15 so it can be measured by the A/D converter U12.

The infrared DC component is separated in a similar manner by switch C of multiplexer U30, low-pass filter R76 and C31, and amplifier U18. Amplifier U18 passes infrared DC signal (IRDC) to the multiplexer U13-12 so it can be measured by the A/D converter U12.

Low-pass filter

The amplified signal from U37 passes through a switched low-pass filter consisting of resistor R37, switch B of U30, switch C of U22, capacitors C30 and C42, and amplifier U29. Since the DC components have been separated and measured previously, it is not necessary to filter the dark time. Switch B of U30 and capacitor C30 filter the signal during the red LED on time, and switch C of U22 and capacitor C42 filter the signal during the infrared LED on time. Amplifier U20 buffers the signal to prevent loading by further stages of filtering.

DC stripper (high-pass filter)

The switched high-pass filter, consisting of switches B and C of U31, capacitors C32 and C33, and resistor R12, removes the DC signal components from amplifier U29. Switch B of U31 and capacitor C32 pass the pulsatile signal component from amplifier U29 during the red LED on time. Switch C of U31 and capacitor C33 pass the pulsatile signal component from amplifier U29 during the infrared LED on time.

AC gain

Under microprocessor control, analog multiplexer U23 selects one of seven resistors (R30 through R36) or an open circuit (U23-13) to combine with feedback resistor R11 to set the gain of amplifier U24. The nominal gains selectable are:

Input number	Input control			Nominal gain
	A	B	C	
0	0	0	0	1
1	0	0	1	9
2	0	1	0	17
3	0	1	1	33
4	1	0	0	66
5	1	0	1	128
6	1	1	0	256
7	1	1	1	525

Red/infrared separator

Switches A and B of U22 separate the red and the infrared pulsatile signals into two independent channels. Resistor R10 and capacitors C18 and C14 also serve as parts of two third-order, low-pass filters in separating the signals. Switch A of U22 passes the red pulsatile signal through to C18; switch B of U22 passes the infrared pulsatile signal through to C14.

The red pulsatile signal passes through the two third-order, low-pass, active filters consisting of resistors R10, R7, and R6; capacitors C18, C13, and C12; and amplifier U15A. The infrared pulsatile signal passes through the third-order, low-pass, active filter consisting of resistors R10, R9, and R8; capacitors C14, C17, and C16; and amplifier U15B.

Calibration

Amplifier U21B compensates for gain differences between the red and infrared signal paths by adjusting the gain in the infrared signal.

Sample and hold

Sample-and-hold circuits U14 and U16 sample the red and infrared pulsatile signals simultaneously so that they can be measured by the A/D converter U12. Signal S/H at U14-8 and U16-8 controls the timing of pulsatile signal sampling at a rate synchronous to the power-line frequency. This sampling frequency helps to suppress interference generated from sources connected to line power such as room lighting.

Probe identification

Amplifier U25C, with feedback resistor R40, generates a voltage proportional to the identification resistor contained in the probe. This voltage passes through a low-pass filter (R64, C62) to the input of analog multiplexer U20 to be measured by the A/D converter U12.

Analog multiplexer

Analog multiplexers U13 and U20 select one of the 16 analog signals to be measured by the A/D converter U12. Amplifier U28 buffers the signal selected.

A/D converter

U12 is a 12-bit, successive-approximation-type analog to digital converter. The microprocessor uses the A/D converter to make all necessary analog measurements. The microprocessor commands the A/D converter to take a measurement by writing to hex memory address C008, and reads the results of the measurements from the same memory address.

Interference detection

The circuit described below detects the presence of most interfering signals that may affect the accuracy of the oximeter or otherwise interfere with its operation.

Switch A of U42 samples the output of the photodetector preamplifier U39 during the time that the red LED is on. Resistor R70 and capacitor C63 delay the rising edge of control signal RLT, which controls switch A of U42. Diode CR8 prevents the falling edge from being delayed. Capacitor C64 and resistor R72 allow high frequencies to pass and hold the DC level stable at U42-13 when switch A is off. High-pass filter C65, R71C37, R28 removes any DC component from the inter allows high-frequency interference to pass while blocking out lower frequency signals.

U43 amplifies the high-frequency interference signal to a level that can be measured easily. High-pass filter C37, R28 removes any DC component from the interference signal. Diode CR4 rectifies the interference signal and places the peak voltage on capacitor C36. Resistor R68 helps to smooth the peak-to-peak variations in the interference. Resistor R29 slowly bleeds the charge off C36 so that the voltage on C36 returns to zero when interference is no longer present. The interfering signal is therefore converted to a DC voltage on C36 that is proportional to the amplitude of the signal. Analog multiplexer U20 passes this voltage to the A/D converter for measurement. The microprocessor declares that interference is detected when the voltage on C36 is greater than approximately 600 millivolts.

Audio frequency control

The circuit consisting of D/A converter U2, dual amplifier U1, and associated circuitry generate an audio frequency signal that is used to drive the speaker. The microprocessor controls the frequency of this signal by loading an 8-bit number into the holding register of U2 at hex I/O address 05. The frequency is approximately:

$$f = \frac{n}{1024RC} = \frac{n}{.22528}$$

where n is the decimal equivalent of the 8-bit number loaded into U2, R is the full-scale resistance of the D/A converter U2, and C is the capacitance of C1 (.022 μ f).

The integrator U1B outputs a triangular waveform that swings between +VREF and -VREF.

Audio volume control

The audio signal volume is controlled by the programmable gain amplifier consisting of D/A converter U3, amplifier U4A, and feedback resistor R3. the microprocessor controls the amplifier gain by loading an 8-bit number into the holding register of U3. The amplifier gain (G) is approximately:

$$G = \frac{3n}{256}$$

where n is the decimal equivalent of the 8-bit number loaded into U3. The output of U4A feeds the audio power amplifier on the digital board.

3/Test and Calibration

This chapter provides procedures to

- Verify that the oximeter and its keys are functioning properly.
- Access and verify user calibration mode.
- Access diagnostics mode and perform the various circuit and functionality tests accessible in that mode.
- Test leakage current and ground resistance.

WARNINGS: Patient safety

- Do not, under any circumstances, perform any testing or maintenance on the oximeter or probe when it is being used to monitor a patient.
- To prevent patient injury or equipment damage, use only oximeter probes identified for this monitor (see the instructions for the probe you are using).
- If a probe is damaged in any way, discontinue use immediately.
- If the oximeter fails any part of the functional, calibration, or leak tests, remove it from operation until qualified service personnel have corrected the situation.

3.1 Functionality test

1. Plug the oximeter into the AC power supply.
2. Connect a probe to the oximeter.
3. Place the probe on your finger.
4. Press Power/Standby to turn the oximeter on.
5. If necessary, adjust the display with the contrast adjust thumb wheel.
6. Verify
 - a. The alarm light flashes and the alarm beeps.
 - b. Figure 8's appear on the digital display.

c. OHMEDA

3700/3710/3700e

Revision: X

SYS AND CAL CHECK

appears on the graphic display. (X represents the alphanumeric value of the currently installed software level)

- d. SYSTEM OPERATIONAL appears.
 - e. That there is a strong signal and a good waveform.
 - f. That verifiable readings appear on the digital display. See "Signal and data validity" in 2/Operations of the Operator's manual.
7. Unplug the oximeter from the AC power supply and verify that BT appears on the graphic display..
8. Plug the oximeter back into the AC power supply and verify that BT no longer appears on the display.
9. Verify, in the following order, that the front panel keys function properly.
- SpO₂ Trend 20/60 displays the trend graph and toggles between 20- and 60-minute trend graph displays.
 - Wave Form restores the plethysmographic waveform.
 - Pulse Volume adjusts the volume setting for the pulse tone.
 - Alarm Volume adjusts the volume setting for the audible alarms.
 - Low SpO₂ raises or lowers the low SpO₂ alarm limit.
 - High SpO₂ raises or lowers the high SpO₂ alarm limit.
 - Low Pulse raises or lowers the low pulse rate alarm limit.
 - High Pulse raises or lowers the high pulse rate alarm limit.
10. Verify that the patient alarms are functional.
- a. Set the high and low SpO₂ and pulse rate alarm limits beyond the readings.
 - b. Make sure the alarm tone sounds and that the violated alarm limit and reading flash on the digital display.
- Note:** A delay in the audible alarm and red alarm light may occur for low SpO₂ when the alarm filter is active.

11. Press and verify that
 - a. Alarm silence temporarily silences all audible alarms for 120 seconds and changes the flashing red alarm light to a steady red light.
 - b. Wave Form (hold for 3 seconds to enter each mode) puts the oximeter into Fast and then Slow response mode, and that F and then S appear for their respective modes.

3.2 User calibration mode

To access and verify calibration mode,

1. Press Low SpO₂ ▼ and Power/Stndby simultaneously.
2. Verify that
 - a. The alarm light flashes and the oximeter beeps.
 - b. Figure 8's appear on the digital display.
 - c. The OHMEDA 3700/3710/3700e ... message appears.
 - d. After which the following message appears:
SpO₂ & PULSE ANALOG
OUTPUTS = 0 VOLTS
WAVEFORM: NEXT TEST,
TREND: QUIT
3. Press Wave Form. The following message appears:
SpO₂ & PULSE ANALOG
OUTPUTS = 1 VOLTS
WAVEFORM: NEXT TEST,
TREND: QUIT
4. Press Wave Form. The following message appears:
** CALIBRATE UNIT **
ADJUST POT AT BOTTOM
HOLE TO VALUE = 0 ± .1
HIT WAVEFORM TO END
5. To return to operation, press Wave Form one more time.

3.3 Diagnostics mode procedures

This section covers

- Accessing diagnostics mode.
- Verifying SpO₂ and Pulse Rate output-port voltage.
- Adjusting the calibration pot.
- Performing the following tests:
 - ROM
 - Power-source frequency
 - Digital-interface circuit
 - Graphic- and digital-display circuits
 - Audio-tone circuit
 - Volume-control circuit
 - SpO₂ D/A converter ramp
 - Pulse rate and LED D/A converter ramp
 - R/IR ratio/phase
 - Probe identification
 - RAM
 - Watchdog timer

Equipment required

- Digital multimeter - Fluke 8022B or equivalent
- Small, flat-blade screwdriver - plastic or nonconductive
- Chart recorder - Ohmeda 0001 or equivalent
- DB 25P shorting plug with pins 2 and 3 connected
- Ohmeda FingerProbe

To access diagnostics mode,

1. Plug the oximeter into the AC power supply.
2. Press Alarm Volume and Power/Stndby simultaneously.
3. Verify that
 - a. The alarm light flashes and the oximeter beeps.
 - b. Figure 8's appear on the digital display.
 - c. The OHMEDA 3700/3710/3700e ... message appears.

Important

If at any time during the following tests the oximeter does not operate as describe, refer to 4/Messages and Troubleshooting for additional information.

3.3.1 SpO₂ and pulse rate analog outputs

WARNINGS:

- **Data validity**—To prevent inaccurate patient readings, the digital voltmeter used in reference voltage test procedures must be accurately calibrated.
- **Electric shock hazard**—Because the unit is not grounded when it is operated on battery power, do not connect any equipment to the signal input/output ports on the rear panel unless the unit is connected to the AC main power supply.

CAUTION: To prevent improper loading, which upsets the correspondence between the measured voltage and the intended output voltage, connect only a high impedance device (1 K Ω or higher) to the analog output.

This test provides zero and full-scale voltages at the analog output ports so a chart recorder connected to the analog output ports can be calibrated.

1. After accessing diagnostics mode (section 3.3), the following message appears:

```
SpO2 & PULSE ANALOG
OUTPUTS = 0 VOLTS
WAVEFORM: NEXT TEST,
TREND: QUIT
```

2. Use the digital voltmeter (DVM) to check for $0 \pm .010$ Vdc at both SpO₂ and Pulse Rate ports on the rear panel.
3. Press Wave Form and verify that the message now shows that OUTPUTS = 1 VOLT.
4. Use the DVM to verify that $1.000 \pm .010$ Vdc appears at the SpO₂ and pulse rate output ports on the rear panel.

Do not adjust R52 on the analog board while monitoring the SpO₂ output port voltage. Adjust R52 while monitoring V_{ref} NOT the SpO₂ analog port. V_{ref} is available only at the board level (at U35, pin 1 or C60 +side) and, if necessary, should be adjusted to 1.010 ± 0.005 Vdc.

5. Use the DVM to verify that $1.00 \pm .025$ Vdc appears at the Pulse Rate output port on the rear panel.
6. Press Wave Form to proceed to the next test.

3.3.2 Calibration test

1. The message on the display should be

```
  ** CALIBRATE UNIT **  
  ADJUST POT AT BOTTOM  
  HOLE TO VALUE = 0± .1  
  HIT WAVEFORM TO END
```
2. After the oximeter has stability for 10 seconds, verify that the digital display reads 0.0 ± 0.1 . If it does not,
 - a. Locate the calibration access hole on the bottom of the oximeter.
 - b. Locate the calibration potentiometer (an adjustment screw) that is directly inside the oximeter (R25 on the analog board).
 - c. Use a small, flat-blade, plastic or nonconductive screwdriver to turn the potentiometer slowly in either direction. Watch the calibration reading on the digital display.

Continue turning until the reading is $0.0 (\pm 0.1)$ —wait for it to stabilize.
3. Press Wave Form to proceed to the next test.

3.3.3 ROM test

This test verifies the ROM contents against a checksum that is stored in ROM.

1. The message on the display should be:

```
  ROM TEST  
  IN PROCESS
```
2. Verify that the following message appears after a few seconds:

```
  ROM TEST OK
```
3. Press Wave Form to proceed to the next test.

3.3.4 Power source frequency test

1. The message on the display should be:

```
  FREQUENCY DETECTED =  
  XX HERTZ  
  WAVEFORM: NEXT TEST,  
  TREND: QUIT
```

Note: XX will be 50, 60, or 400, depending on local frequency.
2. Unplug the oximeter and verify that BATTERY appears as the detected frequency.

3. Plug the oximeter in again and press Wave Form to proceed to the next text.

3.3.5 Digital interface circuit test

1. The message on the display should be:

UART LOOP TEST

STATUS: OPEN LOOP

WAVEFORM: NEXT TEST,

TREND: QUIT

The message will flicker.

2. Connect a DB 25P shorting plug to the RS-232C serial connector. This connects pin 2 to pin 3.
3. Verify that the following message appears:
STATUS: OPERATIONAL
4. Remove DB 25P and then press Wave Form to proceed to the next test.

3.3.6 Graphic display test

1. The message on the display should be:

GRAPHIC DISPLAY TEST

WAVEFORM: NEXT TEST,

TREND: QUIT

2. Verify that the following occurs:
 - a. The graphic display fills with a row of black pixels, moving from top to bottom.
 - b. When the display is filled with the black pixels, a row of blank or transparent pixels fills the display, moving from top to bottom.
 - c. The test repeats until you press the Wave Form or SpO₂ Trend 20/60 key.
3. Press Wave Form to proceed to the next text.

3.3.7 Digital display test

1. The message on the display should be:

NUMERIC DISPLAY TEST

WAVEFORM: NEXT TEST,

TREND: QUIT

2. Verify that the following occurs:
 - a. On the digital display, the number .8 (decimal point eight) scrolls from left to right across the SpO₂ and pulse rate readings, and the number 8 (eight, no decimal) scrolls across the SpO₂ and pulse rate limits.
 - b. The digital display (readings and limits) then counts from 0 to 9, -, E, H, L, P, and blank, with all decimal points in the readings turned on.
 - c. The test repeats until you press the Wave Form or SpO₂ Trend 20/60 key.
3. Press Wave Form to proceed to the next text.

3.3.8 Speaker pitch test

1. The message on the display should be:

SPEAKER PITCH

TEST

WAVEFORM: NEXT TEST,

TREND: QUIT

2. The speaker tone pitch increases in ten steps.
3. The test repeats until you press the Wave Form or SpO₂ Trend 20/60 key.
4. Press Wave Form to proceed to the next text.

3.3.9 Speaker volume test

1. The message on the display should be:

SPEAKER VOLUME

TEST

WAVEFORM: NEXT TEST,

TREND: QUIT

2. The speaker volume increases in ten steps, first at one frequency and then at another.

3. The test repeats until you press the Wave Form or SpO₂ Trend 20/60 key.
4. Press Wave Form to proceed to the next text.

3.3.10 SpO₂ D/A converter ramp test

CAUTION: To prevent improper loading, which upsets the correspondence between the measured voltage and the intended output voltage, connect only a high impedance device (1 K Ω or higher) to the analog output.

1. The message on the display should be:

SpO₂ D/A CONVERTER
RAMP TEST
WAVEFORM: TEXT TEST,
TREND: QUIT

2. Connect a chart recorder to the SpO₂ output port on the rear panel of the oximeter (for more details, see Appendix B in the Operator's manual).
3. Verify that the chart recorder shows a linear ramp output from zero to full scale.

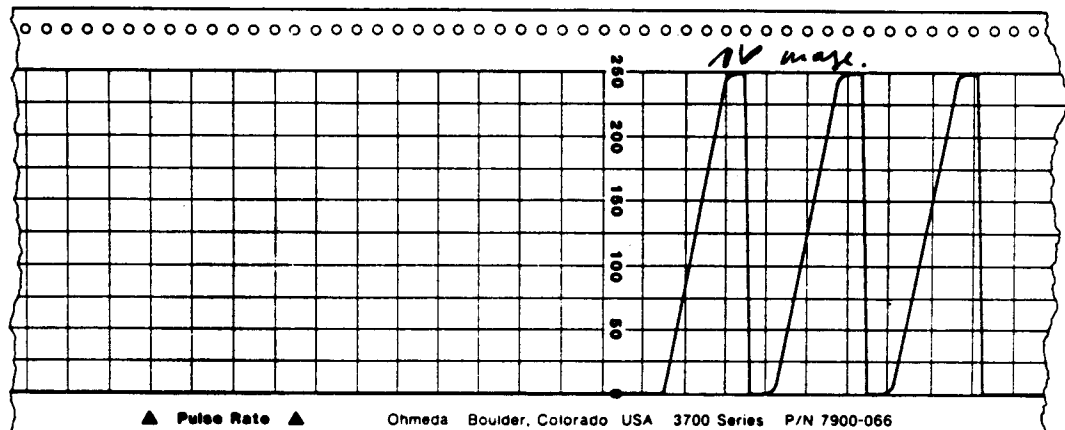

Figure 3-1. Chart recorder linear ramp output.

4. Press Wave Form to proceed to the next text.

3.3.11 Pulse rate and LED D/A converter ramp test

CAUTION: To prevent improper loading, which upsets the correspondence between the measured voltage and the intended output voltage, connect only a high impedance device (1 K Ω or higher) to the analog output.

1. The message on the display should be:

OTHER D/A CONVERTERS
RAMP TEST
WAVEFORM: NEXT TEST,
TREND: QUIT

LED Ramp Test

2. Connect a chart recorder to the Pulse Rate output port on the rear panel of the oximeter (for more details, see Appendix B in the Operator's manual).
3. Verify that the chart recorder shows a linear ramp output from zero to full scale. See Figure 3-1.
4. Connect the FingerProbe to the oximeter.
5. Verify that the red LED in the FingerProbe is lit, slowly gets brighter, goes out, and then repeats.
6. Press Wave Form to proceed to the next text.

3.3.12 DC gain, AC gain, and A/D converter tests

These tests are for manufacturing purposes only; you bypass each one.

1. When you see DC GAIN TEST NOW TESTING STAGE #..., press Wave Form **before** a number appears on the digital display to bypass this test.
2. When you see AC GAIN TEST NOW TESTING STAGE #..., press Wave Form **before** a number appears on the digital display to bypass this test.
3. When you see A/D CONVERTER TEST..., press Wave Form **before** a number appears in the SpO₂ reading position on the digital display to bypass this test.

3.3.13 R/IR ratio/phase test

This test measures the phase difference of the calibration signal between the red and infrared channels.

1. The message on the display should be:

DFT TEST

SPO2=RATIO PR=PHASE

WAVEFORM: NEXT TEST,

TREND: QUIT

2. The digital display shows

- A red to infrared amplitude ratio of $.50 \pm .05$ in the SpO₂ reading position.
- A phase difference of 0 ± 1 in the Pulse Rate reading position.
- A calibration signal frequency reading of 30 ± 5 in the low SpO₂ Alarm Limit position.

3. Press Wave Form to proceed to the next text.

0.50

0

30

3.3.14 Probe identification test

1. If no probe is plugged into the oximeter, the message reads

CANNOT IDENTIFY

PROBE

WAVEFORM: NEXT TEST,

TREND: QUIT

Or

- If a probe is plugged into the oximeter, the message reads

PROBE IDENTIFIED

WAVEFORM: NEXT TEST,

TREND: QUIT

and the bin number appears in the digital display.

2. Press Wave Form to proceed to the next text.

3.3.15 RAM test

Important

Running the RAM test erases any existing trend data and frequency information in memory.

1. The message on the display should be:

RAM TEST --- DATA

WILL BE DESTROYED!

WAVEFORM: SKIP TEST,

TREND: START

2. To retain the trend and frequency information, press Wave Form.

The oximeter skips this test and proceeds to the next one.

Or

- a. To start the RAM test, press SpO₂ Trend 20/60.

Within a few seconds the RAM TEST OK message appears.

- b. Press Wave Form to proceed to the next text.

3.3.16 Watchdog timer test

This test verifies that the processor shuts the unit down properly.

1. The message on the display should be:

WATCHDOG TIMER

TEST

WAVEFORM: SKIP TEST,

TREND: POWER DOWN

2. Press SpO₂ Trend 20/60

The oximeter turns off. All diagnostics tests have been completed.

3.4 Leakage current and ground resistance test

Perform this test

- Whenever an external device is connected to the analog or serial port.
- After you have performed any service on the oximeter.

WARNING: Electric shock hazard—Measure the oximeter's leakage current whenever an external device is connected to either the analog or serial port. Leakage current must not exceed 50 microamperes.

1. With the power cord connected **only to the oximeter**, measure the resistance from the power plug ground prong/connector to all exposed metal on the chassis. The measured resistance must not exceed 0.1 Ω .
2. Measure the leakage current of the oximeter following the instructions supplied with the leakage current tester. The leakage current must not exceed 50 microamperes in any mode.
3. Record the results. for reference in future resistance/leakage tests. A significant change may indicate a pending failure.

4/Messages and Troubleshooting

This chapter provides

- A chart of the messages that may appear on the oximeter: the message, the possible cause(s), the recommended action(s).
- Troubleshooting tables to help you solve diagnostics test and operational problems.

4.1 Messages

Note: Diagnostics mode messages are not included here. See section 4.2, Troubleshooting.

Message	Possible cause(s)	Recommended action(s)
A/D CONVERTER FAILURE, SERVICE UNIT	Oximeter unable to complete the analog-to-digital conversion. Oximeter alarms at volume 10 and then shuts down.	Replace analog board.
ALARM VOLUME HOLD KEY TO SET, VOLUME LEVEL IS #	Appears when you press the Alarm Volume key. # represents the current level set.	Hold key down until desired volume level appears.
ALARM FILTER OFF	Appears briefly when the Alarm silence key is held or three seconds to deactivate the alarm filter.	No action required.
ALARM FILTER ON	Appears briefly when the Alarm silence key is held down for three seconds to activate the alarm filter.	No action required.
ALL MUTE	Appears when the all mute feature is activated.	No action required. (Press once to deactivate.)
ANALOG SYNCHRONIZATION ERROR, SERVICE UNIT	Oximeter unable to synchronize with the analog circuitry.	Replace analog board.
BATTERY IN USE	Appears briefly during power-up when the oximeter is operating on battery power.	No action required.
BT	Appears next to the waveform when the oximeter is operating on batter power.	No action required.

4/Messages and Troubleshooting

Message	Possible cause(s)	Recommended action(s)
CALIBRATE UNIT ADJUST POT AT BOTTOM HOLE TO VALUE = $0 \pm .1$	Appears after initial self-test if oximeter is out of specification.	Calibrate the unit. See "User calibration mode" in chapter 3.
CALIBRATION PASSED SYSTEM OPERATIONAL	Appears after initial self-test when the oximeter has passed all performance tests.	No action required.
CANNOT IDENTIFY PROBE (SEE MANUAL)	Oximeter can't identify the connected probe.	Replace probe; see probe instruction sheet. If condition persists, reseat probe connector and/or connections to the analog board. If condition persists, replace analog board.
CHARGING CIRCUIT FAILURE, SERVICE UNIT	Battery charger/regulator is defective. Battery is defective. Oximeter's internal circuitry has failed.	Perform the battery charger circuit adjustment. If condition persists, replace regulator. Check that battery voltage is above 7.3V after 1 hour of battery operation. Replace if defective. Replace power supply board.
CHECK PROBE SITE	Appears when SpO ₂ readings may be invalid due to motion or incorrect probe site or placement. Appears during Stage 3 alarm condition.	For either cause, reposition or relocate probe.
F	Appears next to the waveform when the oximeter is in Fast response mode (3-second averaging).	No action required.
FAST RESPONSE SELECTED	Appears briefly when the Wave Form key is held for 3 seconds to select Fast response mode.	No action required.
INSUFFICIENT LIGHT DETECTED, CHECK PROBE SITE	Dirt on the probe emitter, probe detector, or at test site. Misaligned or poorly positioned probe. Insufficient light penetrating tissue site. Fingernail polish present. Dark pigmentation. Detector failure.	Clean the probe. Clean the test site. Reposition the probe or select another test site. Reposition the probe or select another test site. Remove polish or use the EarProbe. Select another test site. Replace probe. If condition persists, replace analog board.

4/Messages and Troubleshooting

Message	Possible cause(s)	Recommended action(s)
INTERFERENCE DETECTED, SpO2 & PULSE RATE MAY BE INVALID	Appears when the signal is too erratic to be processed. Response mode time period required for the message to appear: Slow 24 seconds Normal 24 seconds Fast 12 seconds	No action required. May be caused by strong radio frequency (RF) interference possibly generated by electrocautery. If condition persists, check and, if necessary, replace analog and/or digital board.
LO BT	Appears beside the waveform when approximately 5 minutes of battery operation remain. Does not appear when viewing a trend graph.	Within 5 minutes, put the oximeter in Off/Standby mode and plug it into the AC power supply to recharge the battery.
LO QUALITY SGNL (software revision T through 22 only)	Probe off patient. Perfusion insufficient for valid readings. Motion at probe site, electrical noise, or incorrect probe placement.	Reattach the probe. Check patient and oximeter setup. Check patient and oximeter setup.
MICRO-PROCESSOR ERROR, SERVICE UNIT	Appears during initial self-test if oximeter is not operating correctly.	Replace digital board.
MICRO-PROCESSOR INTERRUPT ERROR, SERVICE UNIT	Microprocessor has received an illegal interrupt.	Replace digital board.
N	Appears next to the waveform when the oximeter is in Normal response mode (6-second averaging).	No action required.
NO PROBE CONNECTED TO UNIT	Probe not fully inserted into the probe connector. May be an incorrect probe. Defective probe jack.	Insert probe plug into the connector. Refer to the instructions for the probe you are using. Check probe connector and connections to analog board. If necessary, replace analog board.
NO PULSE	Appears when the bar graph shows a signal strength at 1 pixel or less for 5 seconds or more, or when the pulse rate readings are less than or equal to 20 bpm for 5 seconds or more.	Check attachment and placement of probe. Have patient remain as motionless as possible. Perfuse probe site and reattach the probe. Select another probe site.
NORMAL RESPONSE SELECTED	Appears briefly when you've selected Normal response mode.	No action required.

4/Messages and Troubleshooting

Message	Possible cause(s)	Recommended action(s)
OHMEDA-BIOX 3700/3710/3700e REVISION: X SYS AND CAL CHECK	Appears briefly when you power on the oximeter. X represents the current software revision level.	No action required.
OUTPUTTING TREND, TIME REMAINING X:XX HIT TREND KEY TO END OUTPUT	Appears while the oximeter is outputting trend data through the SpO ₂ , pulse rate, analog, or serial ports	No action required. Time remaining, X:XX, represents both the hours and minutes of trend data left to be output and the minute and seconds it will take to complete the output. (1 hr = 1 minute)
PLEASE PLUG UNIT INTO WALL OUTLET TO DETERMINE LINE FREQUENCY	Appears at power-up when the oximeter has lost battery-packed RAM and is operating on battery power.	Put the oximeter in Off/Standby mode and plug it into the AC power supply.
PLUG UNIT INTO WALL OUTLET TO RECHARGE BATTERY	Battery unable to supply sufficient power. Unit will automatically shut off in 10 seconds.	Put the oximeter in Off/Standby mode and plug it into the AC power supply.
POWER SUPPLY FAILURE, SERVICE UNIT	The oximeter's power supply has failed. Unit will automatically shut off in 10 seconds.	Check voltage at J2-5. If < 2.5 Vdc, replace power supply board. If ≥ 2.5 Vdc, replace digital board.
PREVIOUS TREND DATA AVAILABLE	Appears when Trend key is held down while you're turning on the oximeter so you can view or output previous trend data.	No action required.
PROBE OFF PATIENT Note: This message may not appear if you're using the Flex II, EasyProbe, or SoftProbe.	Probe is off patient. Too much light detected by the probe's photodetector. Extremely thin tissue at the probe site.	Reattach the probe. Shield the probe from ambient light. Find another probe site.
PROBE OR CIRCUIT FAILURE REPLACE PROBE OR SERVICE UNIT	Artificial nail tips or long fingernails present. Broken probe cable wire or inoperative LEDs; probe has failed. Oximeter's probe circuitry has failed.	Do not attempt nail removal. Find another probe site. Replace probe. If condition persists, replace analog board .
PULSE VOLUME HOLD KEY TO SET, VOLUME LEVEL IS #	Appears when you press the Pulse Volume key. # represents the current level set.	Hold down the key until the desired volume level appears.

Message	Possible cause(s)	Recommended action(s)
PULSE WAVEFORM SELECTED	Appears briefly when you press the Wave Form key during a probe alarm condition.	No action required.
RAM CHECK ERROR, SERVICE UNIT	Appears when a periodic check has found an error during monitoring.	Replace digital board.
RAM DATA INVALID, RE-INITIALIZING	The oximeter's memory erased; trend data is lost. The unit reinitializes automatically and is then ready for use.	No action required.
RAM TEST ERROR HIGH BYTE, SERVICE UNIT	Appears after the initial self-test if a RAM failure exists.	Replace digital board.
RAM TEST ERROR HIGH & LOW BYTES, SERVICE UNIT	Appears after the initial self-test if a RAM failure exists.	Replace digital board.
RAM TEST ERROR LOW BYTE, SERVICE UNIT	Appears after the initial self-test if a RAM failure exists.	Replace digital board.
RAM TEST ERROR TREND CHECKSUM, SERVICE UNIT	Appears after the initial self-test if a RAM failure exists.	Replace digital board.
ROM TEST ERROR HIGH & LOW BYTES, SERVICE UNIT	Appears after the initial self-test if a ROM failure exists.	Replace digital board.
ROM TEST ERROR LOW BYTE, SERVICE UNIT	Appears after the initial self-test if a ROM failure exists.	Replace digital board.
S	Appears next to the waveform when the oximeter is in Slow response mode (12-second averaging).	No action required.
SLOW RESPONSE SELECTED	Appears briefly when you hold the Wave Form key for 3 seconds to enter the Slow response mode.	No action required.
STACK ERROR, PLEASE NOTE CONDITIONS AND SERVICE UNIT	Appears when a periodic check of system stack area during monitoring indicates a problem.	Replace digital board.
SYSTEM ERROR X PLEASE NOTE ERROR CODE AND SERVICE UNIT	Appears when a periodic check of software and hardware during monitoring has found a problem. X represents an error code number.	Note the error #. Turn unit off. Call Ohmeda for service information (see back cover of this manual).

4/Messages and Troubleshooting

Message	Possible cause(s)	Recommended action(s)
TEST SIGNAL DC REFERENCE ERROR, SERVICE UNIT	Appears during the initial self-test if a hardware problem exists.	Replace analog board.
THANK YOU UNIT MAY NOW RUN ON BATTERY	Appears after you've plugged the oximeter into the AC power supply in response to the RECHARGE BATTERY message.	No further action required.
TREND MODE SELECTED	Appears briefly when you press the Trend key during an alarm condition (exception: No Probe or Probe Off alarms).	No action required.
TREND OUTPUT MODE, START CHART RECORDER HIT TREND KEY TO START OUTPUT	Appears briefly when the oximeter is ready to begin trend data output.	Press Trend to begin output.
VOLTAGE REFERENCE FAILURE, SERVICE UNIT	Appears during monitoring if a hardware problem exists.	Replace analog board.

4.2 Troubleshooting

When you encounter problems during a diagnostics test or procedure, use Figure 4-1 to locate the possible cause(s).

When an oximeter condition that may not produce a message arises, use Figure 4-2 to locate the possible cause(s).

Diagnostic	Inter-connect Cable	On/Off switch/ fuse/line filter/ transformer	Battery	Power supply board	Analog board	Digital board	Front panel	Calibration	Probe
Analog output = 0 V	X			X	X	X		X	
Analog output = 1 V	X			X	X	X		X	
Calibration				X	X	X		X	
ROM TEST						X			
Frequency detected	X	X		X		X			
UART loop	X					X			
Graphic display	X					X	X		
Numeric display	X					X	X		
Speaker pitch	X				X	X			
Speaker volume	X				X	X			
SpO ₂ D/A	X					X			
Other D/A	X				X	X			
Ratio phase					X				
Probe ID	X				X				X
RAM data				X		X			
Watchdog timer				X	X	X			

Figure 4-1. Diagnostics troubleshooting

4/Messages and Troubleshooting

Symptom	Inter-connect Cable	On/Off switch/fuse/line filter/transformer	Battery	Power supply board	Analog board	Digital board	Front panel	Calibration	Probe
Will not power up on battery	X		X	X		X			
Will not power up on AC	X	X		X		X			
Backlight not lit	X			X		X	X		
Inaccurate readings					X	X		X	X
Interference detected					X	X			
Insufficient light	X				X				X
Visual alarm failure	X					X	X		

Figure 4-2. System troubleshooting

5/Repair Procedures

This chapter provides

- Service and repair policy
 - Obtaining technical assistance and service
 - Packaging and return procedure
- Instructions for frequently used procedures:
 - Removing the cover
 - Removing the front panel assembly
 - Attaching the front panel assembly
 - Installing the cover
- Remove and replace procedures:
 - Front panel
 - Board set
 - Battery
 - Probe connector
 - Software EPROMs
- Adjusting the battery charging circuit
- Adjusting the display contrast
- Measuring the power supply

Important

While performing the following procedures, refer to the end of this chapter, "5.7 Oximeter assembly information," for oximeter illustrations and reference designators.

Note: To clean the oximeter, recharge the battery, or replace a fuse, refer to 4/Maintenance and Service in the *Ohmeda Biox 3700/3700e Operator's Manual*.

5.1 Service and repair policy

Warranty repair and service must be performed by an Ohmeda Service Representative or at the Ohmeda Service and Distribution Center. When Ohmeda's warranty is not applicable, repairs are made at Ohmeda's current list price for replacement parts plus a reasonable labor charge.

Do not use malfunctioning equipment. Make all necessary repairs or have the unit repaired by an Ohmeda Service Representative.

Parts listed in this manual may be repaired or replaced by a competent, trained person who has experience in repairing devices of this nature. We recommend that you use only replacement parts manufactured or sold by Ohmeda.

CAUTIONS: Service

- Only competent individuals trained in the repair of this equipment should attempt to service it.
- Detailed information for extensive repairs is included in this manual solely for the convenience of users having proper knowledge, tools, and test equipment, and for service representatives trained by Ohmeda.

5.1.1 Obtaining technical assistance and service

Inside the USA—Contact Ohmeda Technical Support, which is listed on the back cover.

Outside the USA—Contact the nearest Ohmeda Representative or office listed on the back cover.

5.1.2 Packaging and return procedure

If the oximeter is to be sent to Ohmeda, **please clean** the unit as described in section 1.4 of this manual, using the safety procedures specified. Be sure the unit is **thoroughly dry** before you pack it for shipment.

To return the oximeter to Ohmeda, wrap it in a plastic bag and package it securely (in the original shipping container if possible). Enclose the following items in the package:

1. A letter describing the problem in detail.
2. Warranty information (you must include a copy of the invoice or other applicable documentation).
3. Purchase order number to cover repairs if out of warranty or for tracking purposes if within the warranty period.
4. "Ship To" and "Bill To" information.
5. Person to contact for questions (country, name, and telephone/Telex/fax number).

After calling,

Inside the USA—ship the oximeter prepaid to:

Ohmeda Service and Distribution Center
7750 The Bluffs NW
Austell, GA 30001

Outside the USA—send the oximeter to your local authorized service office as shown on the back cover of this manual.

Important: Upon receipt of a repaired monitor, complete the Functionality Test to verify proper operation of the oximeter—see section 3.1.

5.2 Frequently used procedures

Most repairs require the use of certain procedures, such as the removal and subsequent installation of the cover. To avoid unnecessary repetition, the procedures are included here; references to them are provided where appropriate.

Equipment and tools

- Phillips screwdriver, #2

WARNING: Electric shock hazard

- Before service or cleaning the oximeter, turn the unit off and disconnect the power cord from the AC power supply.
- Do not touch any exposed wiring or conductive surface while the cover is removed. The voltage present when electrical power is connected to the oximeter can cause serious injury or death.
- Never wear a grounding wrist strap when working on an energized oximeter.

CAUTION: Static sensitivity

- Work at a static-control workstation and wear a static-control wrist strap to discharge accumulated static charges from you and any tool you use.
- Use nonconductive tools.
- Handle circuit boards (replacement and defective) by their nonconductive edges. Use anti-static containers to transport them.

5.2.1 Removing the cover

1. Turn the oximeter off and disconnect it from the AC power supply.
2. Disconnect any probe from the oximeter.
3. To remove the cover,
 - a. Turn the unit upside down.
 - b. Remove the four #6-32 x 2½" Phillips-head screws.
 - c. Turn the unit right side up.
 - d. Press gently on the sides of the cover and lift it off.

5.2.2 Removing the front panel

1. Turn the oximeter off and unplug it from the AC power supply.
2. Remove the oximeter cover—see section 5.2.1.
3. While being very careful not to pull on any wires, lift the front panel off the oximeter.
4. To remove the front panel from the oximeter, disconnect the following components:
 - a. This step **only** for display board A118-004, Rev V, or lower:
 - Graphic display module connector A1A2P1 from connector A4J3 on the power supply board (top board in the board set).
 - Display board connector A1W4 from connector A4J4 on the power supply board.

Display board versions 6050-0003-302 and A118-004, perform these steps:

- b. Ribbon cable A1W3 (pull back the latches) from connector A3J4 on the digital board (middle board).
- c. Probe cable A1W2 from connector J1 on the interface board (small printed circuit board in front of the board set).
- d. Cable W3 from connector clip A1A1J2 on the display board (on front panel).
5. Place the front panel aside.
6. Gently pull straight back on the interface board until connector J2 (on the rear side) unplugs from the connector on the bottom of the analog board (bottom board of board set).
7. Loosen the nylon screw on the plastic mounting bracket enough to remove the bracket and circuit board from the chassis boss; set aside.

5.2.3 Replacing the front panel

1. To install the interface board,
 - a. Slide the plastic mounting bracket over the chassis boss on the front left side of the unit with connector J1 on the interface board at the top, facing away from the board set.
 - b. Insert connector J2 (on the rear of the board) into the empty connector on the bottom of the analog board (bottom board of board set).
 - c. Tighten the nylon screw on the plastic mounting bracket so that the bracket is snug against the boss.
 - d. Plug probe cable A1W2 into J1 at the top of the interface board.
2. Connect the following:
 - a. Cable W3 to connector clip A1A1J2 on the display board (on front panel).
 - b. Ribbon cable A1W3 to connector A3J4 on the digital board (middle board).
 - c. This step **only** for display board A118-004, Rev V or lower:
 - Connector A1W4 to A4J4 on the power supply board (top board).
 - Connector A1A2P1 to connector A4J3 on the power supply board.
3. Align and place the front panel on the oximeter assembly.
4. Make sure all connectors are snug and no loose hardware is inside the chassis.
5. To replace the oximeter cover, see section 5.2.4.

5.2.4 Installing the cover

1. Verify that
 - The front panel is placed properly on the front of the oximeter chassis—see section 5.2.3.
 - The battery is connected securely—see section 5.6.

WARNING: Electric shock hazard

- **Do not touch any exposed wiring or conductive surface while the cover is removed. The voltage present when electrical power is connected to the oximeter can cause serious injury or death.**
 - **Never wear a grounding wrist strap when working on an energized oximeter.**
2. Before verifying operation, place the oximeter cover carefully over the chassis.
 3. Press Power/Stndby and verify that the displays are lit.

Note: If the battery was not disconnected or was disconnected for less than 2 minutes, the messages in steps 4 and 5 may not appear.

4. Verify that the following sequences of messages appears:
 - OHMEDA-BIOX
 - 3700/3710/3700E
 - REVISION: X
 - SYS AND CAL CHECK

 - RAM DATA INVALID
 - RE-INITIALIZING

 - PLEASE PLUG UNIT
 - INTO WALL OUTLET
 - TO DETERMINE
 - LINE FREQUENCY
5. Plug the oximeter into the AC power supply and verify that the following message appears:
 - THANK YOU
 - UNIT MAY NOW RUN
 - ON BATTERY
6. Finally, verify that the initial OHMEDA 3700/3710/3700E... sign-on message appears followed by
 - SYSTEM OPERATIONAL
7. Turn the oximeter off and unplug it from the AC power supply.
8. Remove the loosely placed cover.
9. Place the cover so the slits on the rear fit over the rear panel.
10. Check for pinched cables; make certain everything is secure inside the chassis.
11. To attach the cover,
 - a. Turn the oximeter upside down.
 - b. Loosely screw in the four #6-32 x 2 $\frac{1}{8}$ " Phillips-head screws into the chassis.
 - c. Tighten the screws until snug—**do not overtighten.**
 - d. Turn the oximeter right side up.

12. Perform the leakage current and ground resistance test—see section 3.4.
13. Before using the oximeter for patient monitoring, always perform the functionality test—see section 3.1.

5.3 Remove and replace procedures

This section covers removing and replacing the following oximeter components for repair, replacement, or maintenance:

- Front panel
- Board set
- Battery
- Probe connector

5.3.1 Front panel

Disassembly

1. Remove the oximeter cover—section 5.2.1.
2. Remove the front panel assembly—section 5.2.2.
3. Remove the following sets of screws:
 - Four #4-40 x 1/4" Phillips-head screws from the graphic display module, A1A2.
 - Two #2-56 x 1" Phillips-head screws from the graphic module interface, A1A3.
 - Four #4-40 Phillips-head screws from the display board, A1A1.
4. Remove the 10-pin, 1-row ribbon cable assembly A1W1 from
 - Graphic display module A1A2
 - Graphic module interface A1A3..
5. Lift the graphic module interface from the display board (A1A1).
6. Unplug ribbon cable A1A4P1 from the display board.
7. Remove the display board.
8. Remove the graphic display module.

The front bezel (A1A4) and the probe cable assembly (A1W2) are all that should remain on the front panel.

Reassembly

1. Clean the back of the display windows with isopropyl alcohol. Remove any lint or dust from the windows.
2. To attach the graphic display module (A1A3) to the front panel, loosely screw in four #4-40 x 1/4" screws. Tighten screws until snug but **not** overtight.
3. To attach the display board (A1A1) to the front panel, loosely screw in four #4-40 x 1/4" screws. Tighten screws until snug but **not** overtight.
4. To attach the graphic module interface (A1A3) to the graphic display module (A1A2), loosely screw in the two #2-56 x 3/4" screws. Tighten screws until snug but **not** overtight.
5. Reconnect the 10-pin, 1-row ribbon cable assembly A1W1 to the
 - Graphic module interface (A1A3).
 - Graphic display module (A1A2).
6. Reconnect ribbon cable A1A4P1 to the display board (A1A1).

5.3.2 Board set

This procedure accesses the board set so you can remove and replace the power supply, digital, and/or analog board.

Disassembly

1. Remove the oximeter cover—see section 5.2.1.
2. Remove the front panel assembly—see section 5.2.2.
3. Disconnect the following power supply board connectors (top board):
 - A4J1 (near the transformer)
 - A4J2 (on the right side of the board near the battery). Pull the cable back towards the rear panel.
 - A4J5 (near the middle of the board).
4. Disconnect and remove the interface board.
5. Disconnect cable assembly W1 from connector A3J3 (near the battery) on the digital board (middle board).
6. Disconnect cable assembly W1 from connector A2J1 on the analog board (bottom board).
7. Loosen the four #6-32 x 1 1/4" Phillips-head screws (item 15) holding the board set.
8. Remove only **three** of the screws and washers, leaving the lower right-corner screw attached **loosely** in the board set.

9. Disconnect connector A3J1 (between the transformer and connector A4J2) on the digital board.
10. Remove the fourth screw and washer from the lower right corner.
11. Lift the board set (3 boards and 2 shields) from the chassis.

Reassembly

1. Reconnect cable assembly W1 to connector A2J1 on the analog board.
2. Place the shield plate (item 26) in the chassis.
3. With the component side **down**, place the analog board (A2) on top of the shield plate in the chassis.

The 60-pin connector socket and cable (W1) should be on the right side.

4. Place the other shield plate (item 10) on the backside of the analog board.
5. With the component side **up**, place the digital board (A3) on top of the shield plate.
6. Reconnect W1 to A3J3 on the digital board.
7. Reconnect A5P1 from the rear panel to A3J1 on the digital board.
8. Reinstall the interface board.
9. Attach the front panel—see section 5.2.3.
10. Install the cover—see section 5.2.4.

5.3.3 Probe connector

Additional tool required:

- Probe socket wrench (0380-0100-254) or needle-nose pliers.

Disassembly

1. Remove the oximeter cover—see section 5.2.1
2. Remove the front panel—see section 5.2.2.
3. Use the probe socket wrench (or needle-nose pliers) to loosen the nut holding the cable to the back of the front panel.
4. Remove the nut and the O-ring from the probe socket.
5. Disconnect the probe cable from the interface board at A6J1.
6. From the front of the panel, pull out the old probe socket and cable.

Reassembly

1. Remove the nut and O-ring from the new probe connector.
2. From the front of the panel, insert the new probe socket and cable assembly into the probe connector hole on the front panel.
3. From the back of the panel, slide the O-ring and then the nut over the probe connector cable.
4. Reconnect the probe cable to the interface board at A6J1.
5. Use the probe socket wrench (or needle-nose pliers) to tighten the nut onto the back of the probe socket. Tighten the nut $\frac{1}{4}$ to $\frac{1}{2}$ turn past the point of contact with the fully seated O-ring.

Optional: Only RTV silicone rubber materials are recommended for use as supplemental nut-locking adhesives.

6. Reattach the front panel—see section 5.2.3
7. Install the cover—see section 5.2.4.

5.3.4 Battery

WARNINGS: Battery replacement

- Faulty battery connections could be hazardous and will void the warranty.
- Reversing the battery connections could result in injury and will permanently damage the circuitry.
- If trained technical personnel are not available, call Ohmeda for assistance.
- For proper operation, replace only with an Ohmeda battery.

Disassembly

1. Remove the oximeter cover—see section 5.2.1.
2. Remove the front panel—see section 5.2.2.
3. Locate battery (B1).
4. Disconnect the red cable from the positive (+) battery terminal and the black cable from the negative (-) battery terminal.
5. Remove the 2 (6-32 x 1/4") Phillips-head screws securing the battery strap to the lower chassis. Set aside for reinstallation.
6. Remove the old battery.

Reassembly

1. Place the new battery into the chassis.
Be sure the positive (+) side of the battery is toward the rear panel.
2. Use the 2 screws you remove earlier to secure the battery strap to the lower chassis.

WARNINGS:

- Reversing the battery connections could result in injury and will permanently damage the circuitry.
 - To prevent failure of the 2-amp fuse on the power supply board, do not cross the battery connections.
3. Reconnect the red cable to the positive (+) battery terminal and the black cable to the negative (-) terminal.
 4. Reattach the front panel—see section 5.2.3.
 5. Install the cover—see section 5.2.4.

5.3.5 Software

Additional tools required:

Small, flat-blade screwdriver or an IC extractor tool

EPR0M removal

1. Remove the cover—see section 5.2.1.
2. Locate the battery (B1):
3. Disconnect the red cable from the positive (+) battery terminal and the black cable from the negative (-) battery terminal.
4. Disconnect the following power supply board connectors:
 - A4J1 (near the transformer)
 - A4J2 (on the right side of the board near the battery). Pull the cable back towards the rear panel.
 - A4J3 (near the front of the board).
 - A4J4 (near the front of the board)
 - A4J5 (near the middle of the board).
5. Remove the 4 (6-32 x 1¼) Phillips-head screws (item 15) holding the board set. Set aside for reinstallation.
6. Lift the power supply board from the board set.
7. Locate the EPROMS (U9 and U18) on the digital board—if necessary, refer to the digital board assembly diagram, section 6.5.1. To remove each EPROM,
 - a. **Digital board Rev M and lower:** Insert a small, flat-blade screwdriver into the latch on the socket holding the EPROM. Gently pull back on the screwdriver until the EPROM releases from the socket.
Digital board Rev N or higher: Use the IC extractor tool, or pry the EPROM out of the socket by gently twisting up and out with a flat-blade screwdriver.

EPRM replacement and reassembly

The replacement EPROMS must be inserted as follows:

EPROM	Revision	Socket
6050-0003-107	23 and higher	U9 HI
6050-0003-103	23 and higher	U18 LO
T118-012	T through 22	U9 HI
T118-013	T through 22	U18 LO
T118-001	M only	U9 HI
T118-013	M only	U18 LO

Digital board Rev M and lower: The notch on the EPROM must be at the same end of the socket as the latch. Do not release the socket locking mechanism prior to installing the EPROM.

Digital board Rev N or higher: The notch on the EPROM must match the notch on the socket.

1. Insert each new EPROM into the correct socket and press firmly. The socket normally offers high resistance to the EPROM.

Make sure that all the pins are in the socket and that none are bent.

2. Place the power supply board on the digital board.

Connector A3J2 must be toward the rear panel with the two large capacitors on the left.

3. Use the 4 screws you removed earlier to screw into the board set.

4. Reconnect the following power supply board connectors:

— A5P2 from the transformer to A4J1.

— W2 to A4J2.

— A1W2 to A4J3.

— A1W4 to A4J4.

— A5P3 to A4J5.

WARNINGS:

- Reversing the battery connections could result in injury and will permanently damage the circuitry.
- To prevent failure of the 2-amp fuse on the power supply board, do not cross battery connections.

5. Reconnect the red cable to the positive (+) battery terminal and the black cable to the negative (-) terminal.

6. Install the cover—see section 5.2.4.

5.4 Adjusting the battery charging circuit

Additional equipment required:

- 470 $\Omega \pm 5\%$ 1/4 watt resistor
- Digital voltmeter (DVM), 0 - 20 Vdc scale

Always use insulated tools when adjusting the oximeter's internal controls.

1. Remove the cover—see section 5.2.1.
2. Locate the battery (B1).
3. Disconnect the red cable from the positive (+) battery terminal and the black cable from the negative (-) battery terminal.
4. Connect the red and black cables to a 470 $\Omega \pm 5\%$ 1/4 watt resistor.
5. Connect a DVM across the resistor to monitor the DC voltage present.

WARNING: Electric shock hazard

- Do not touch any exposed wiring or conductive surface while the cover is removed. The voltage present when electrical power is connected to the oximeter can cause serious injury or death.
- Never wear a grounding wrist strap when working on an energized oximeter.

CAUTION: Static sensitivity

- Work at a static-control workstation and wear a static-control wrist strap to discharge accumulated static charges from you and any tool you use.
 - Use nonconductive tools.
6. Plug the oximeter in the AC power supply.
 7. If the unit is on after plugging it in, press Power/Stndby to turn it off.
The oximeter is still energized.
 8. Adjust R5 on the power supply board so that the voltage displayed on the DVM is between 9.35 and 9.40 volts.
 9. Disconnect the oximeter from the AC power supply.
 10. Disconnect the 470 $\Omega \pm 5\%$ 1/4 watt resistor and the DVM.

WARNINGS:

- Reversing the battery connections could result in injury and will permanently damage the circuitry.
 - To prevent failure of the 2-amp fuse on the power supply board, do not cross battery connections.
11. Reconnect the red cable to the positive (+) battery terminal and the black cable to the negative (-) terminal.
 12. Install the cover—see section 5.2.4.

5.5 Adjusting the display contrast

1. Remove the cover—see section 5.2.1.

WARNING: Electric shock hazard

- Do not touch any exposed wiring or conductive surface while the cover is removed. The voltage present when electrical power is connected to the oximeter can cause serious injury or death.
- Never wear a grounding wrist strap when working on an energized oximeter.

CAUTION: Static sensitivity

- Work at a static-control workstation and wear a static-control wrist strap to discharge accumulated static charges from you and any tool you use.
 - Use insulated tools.
2. Plug the oximeter into the AC power supply and make sure the unit is on.
 3. Connect the test leads of the DVM between J2 pin 3 of the display board and U3 pin 7. Adjust the viewing angle pot (just below the right side of the front panel) for a DVM reading of 2.0 ± 0.1 Vdc.
 4. Connect the leads between J2 pin 3 (black wire) of display board and U3 pin 1 on the display board.
 5. Adjust R3 on the display board for a DVM reading of approximately
 - A118-004, Rev V or lower only: 3.0 Vdc and then adjust the intensity to match the displays.
 - 6050-0003-302 or higher only: 2.3 Vcd and then adjust the intensity to match the displays.
 6. Verify that the viewing angle of both displays track together as you adjust the Contract Adjust thumbwheel.
 7. Power off the unit and unplug it from the AC power supply.
 8. Install the cover—see section 5.2.4.

5.6 Measuring the power supply

Additional equipment required:

- Digital voltmeter (DVM)

1. Remove the oximeter cover—see section 5.2.1.

WARNING: Electric shock hazard

- Do not touch any exposed wiring or conductive surface while the cover is removed. The voltage present when electrical power is connected to the oximeter can cause serious injury or death.
 - Never wear a grounding wrist strap when working on an energized oximeter.
2. Connect the DVM + to J2, pin 4, and the DVM common to J2, pin 25.

3. Verify that the +V RAM standby voltage is 2.4 to 4.5 Vdc.
4. Plug the unit in and turn it on.
5. Connect a DVM to the following points and verify that the voltage is as shown.

DVM		Voltage reading	Supply name
+	common		
J2-4	J2-25	4.75 to 5.25 Vdc	+V RAM
J2-13	J2-25	4.75 to 5.25 Vdc	+5V
J2-23	J2-25	4.75 to 5.25 Vdc	+V
J2-21	J2-25	-4.75 to -5.25 Vdc	-V
J2-17	J2-25	14.25 to 15.75 Vdc	+15V
J2-19	J2-25	-14.25 to -15.75 Vdc	-15V

6. Install the cover—see section 5.2.4.

5.7 Oximeter assembly information

5.7.1 Oximeter assembly illustration

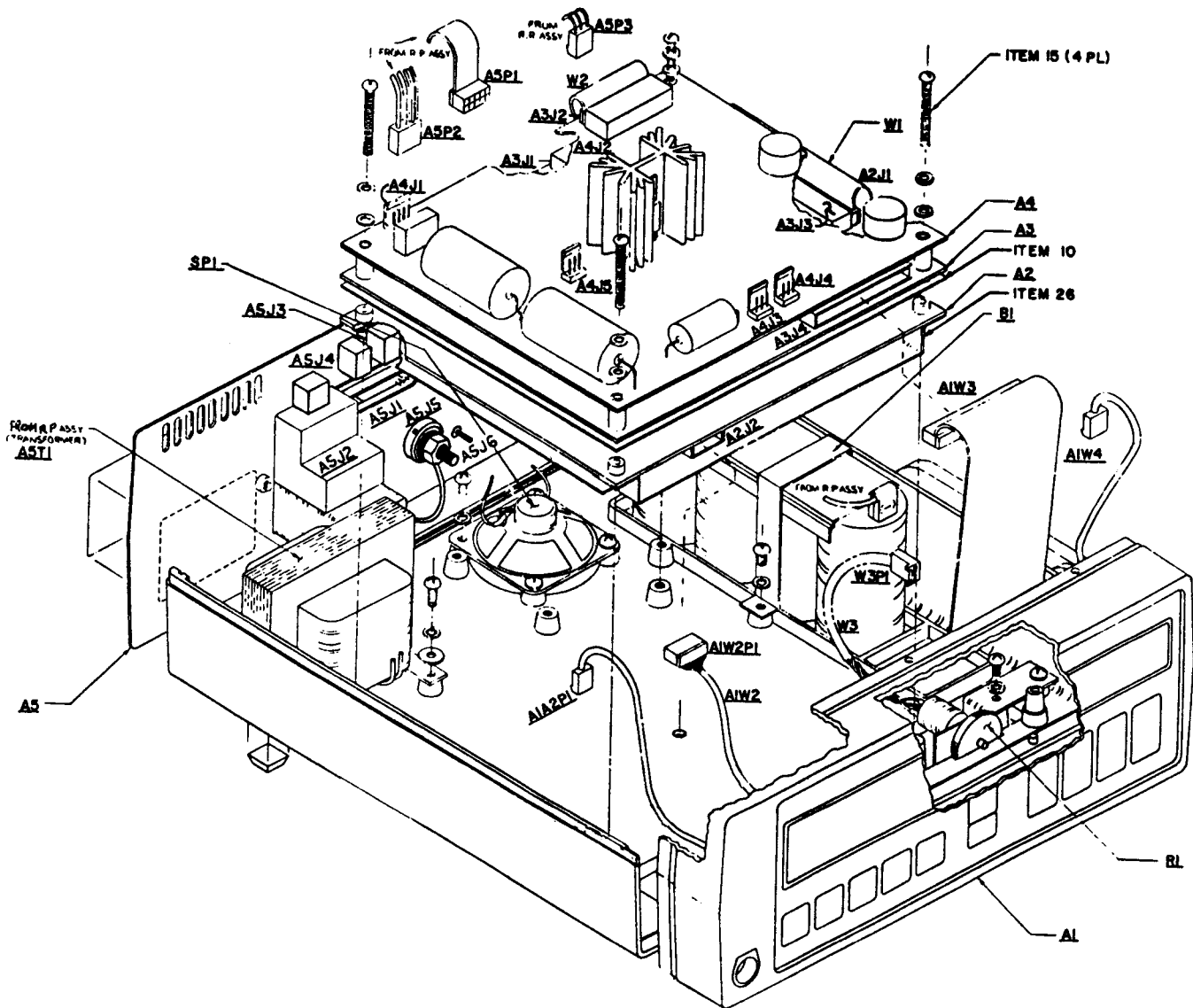

5.7.2 Interface board connections—close view

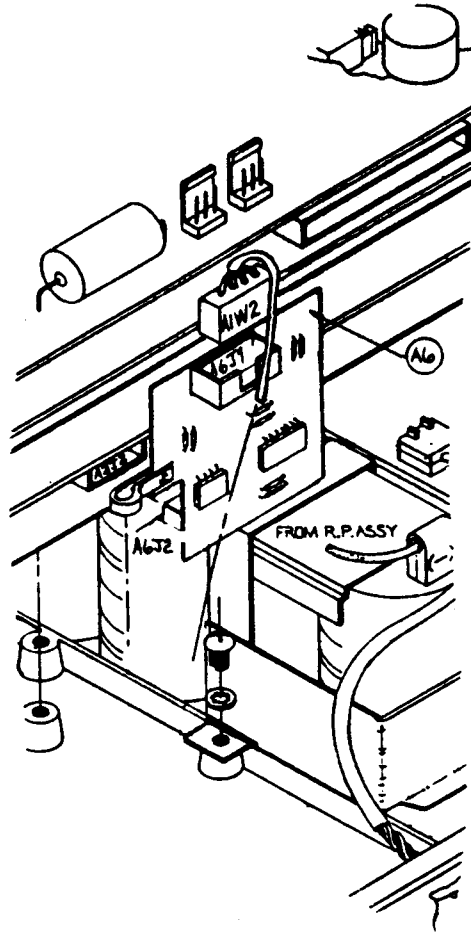

5.7.3 Reference designators

Reference	Description	Connects to
A1	Front panel assembly	
A1A1	Display board assembly	
A1A1J1	E.L. backlight connector	A1W4
A1A1J2	Viewing angle adjust connector	W3P1
A1A1J3	Keyboard connector	A1A4P1
A1A1J4	Digital board interface connector	A1W3
A1A1P1	Graphic control interface	A1A3J1
A1A2	Graphic display module	
A1A2J1	Graphic control interface	A1W1
A1A2P1	E.L. panel backlight	A4J3
A1A3	Graphic control module	
A1A3J1	Digital control interface	A1A1P1
A1A3J2	Graphic display interface	A1W1
A1A4	Keyboard	A1A1J3
A1A4P1	Keyboard connector	A1A1J3
A1W1	Cable assembly	A1A2J1 to A1A3J2
A1W2	Cable assembly	A1W2J1 (probe) to A2J2
A1W3	Cable assembly	A1A1J4 to A3J4
A1W4	Cable assembly	A1A1J1 to A4J4
A2	Analog board assembly	
A2J1	Digital board interface	W1
A2J2	Probe interface	A6J2
A3	Digital board assembly	
A3J1	Analog outputs, digital interface, speaker	A5P1
A3J2	Power supply board connector	W2
A3J3	Analog board interface	W1
A3J4	Display board interface	A1W3

Reference	Description	Connects to
A4	Power supply board assembly	
A4J1	AC power and battery	A5P2
A4J2	Digital board interface	W2
A4J3	Graphic E.L. backlight	A1A2P1
A4J4	Digital display E.L. backlight	A1W4
A4J5	Voltage regulator connector	A5P3
A5	Rear panel assembly	
A5J1	Digital interface connector	
A5J2	AC power input connector	A5J5, A5T1
A5J3	Pulse rate analog output connector	
A5J4	SpO2 analog output connector	
A5J5	Ground equalization connector	A5T1, A5J2, A5P2, A5J6
A5J6	Rear panel ground	A5J5
A5P1	Analog output, digital interface, speaker	A3J1
A5P2	Transformer secondary	A4J1, A5J5
A5P3	Voltage regulator output	A5V1 to A4J5
A5T1	Power transformer	A5J5, A5J2, A5P2
A5V1	Voltage regulator	A1J1
A6J1	Probe cable interface connector	A1W2
A6J2	Analog board connector	A2J2
B1	8-volt battery	
SP1	Speaker	A5P1
W1	Cable assembly	A2J1 to A3J3
W2	Cable assembly	A3J2 to A4J2
W3	Cable assembly	A1A1J2 to R1

6/Parts and Illustrations

The following components are covered in this chapter:

- 6.1 Oximeter assembly
 - 6.1.1 Oximeter assembly illustration
 - 6.1.2 Oximeter assembly parts list
- 6.2 Front panel assembly
 - 6.2.1 Front panel assembly illustration
 - 6.2.2 Front panel parts list
- 6.3 Rear panel assembly
 - 6.3.1 3700 rear panel assembly illustration
 - 6.3.2 3700e rear panel assembly illustration
 - 6.3.3 3700 rear panel parts list
 - 6.3.4 3700e rear panel parts list
- 6.4 Analog board
 - 6.4.1 Analog board diagram
 - 6.4.2 Analog board reference designators
 - 6.4.3 Analog board schematic
- 6.5 Digital board
 - 6.5.1 Digital board diagram
 - 6.5.2 Digital board reference designators
 - 6.5.3 Digital board schematic
- 6.6 Display board assembly
 - 6.6.1 Display board diagram
 - 6.6.2 Display board reference designators
 - 6.6.3 Display board schematic
 - 6.6.4 Membrane panel switch schematic
- 6.7 Power supply board
 - 6.7.1 Power supply board diagram
 - 6.7.2 Power supply board reference designators
 - 6.7.3 Power supply board schematic

Note: Only those items in the parts lists that appear with stock numbers may be ordered through Ohmeda or an authorized representative.

6.1 Oximeter assembly

6.1.1 Oximeter assembly illustration

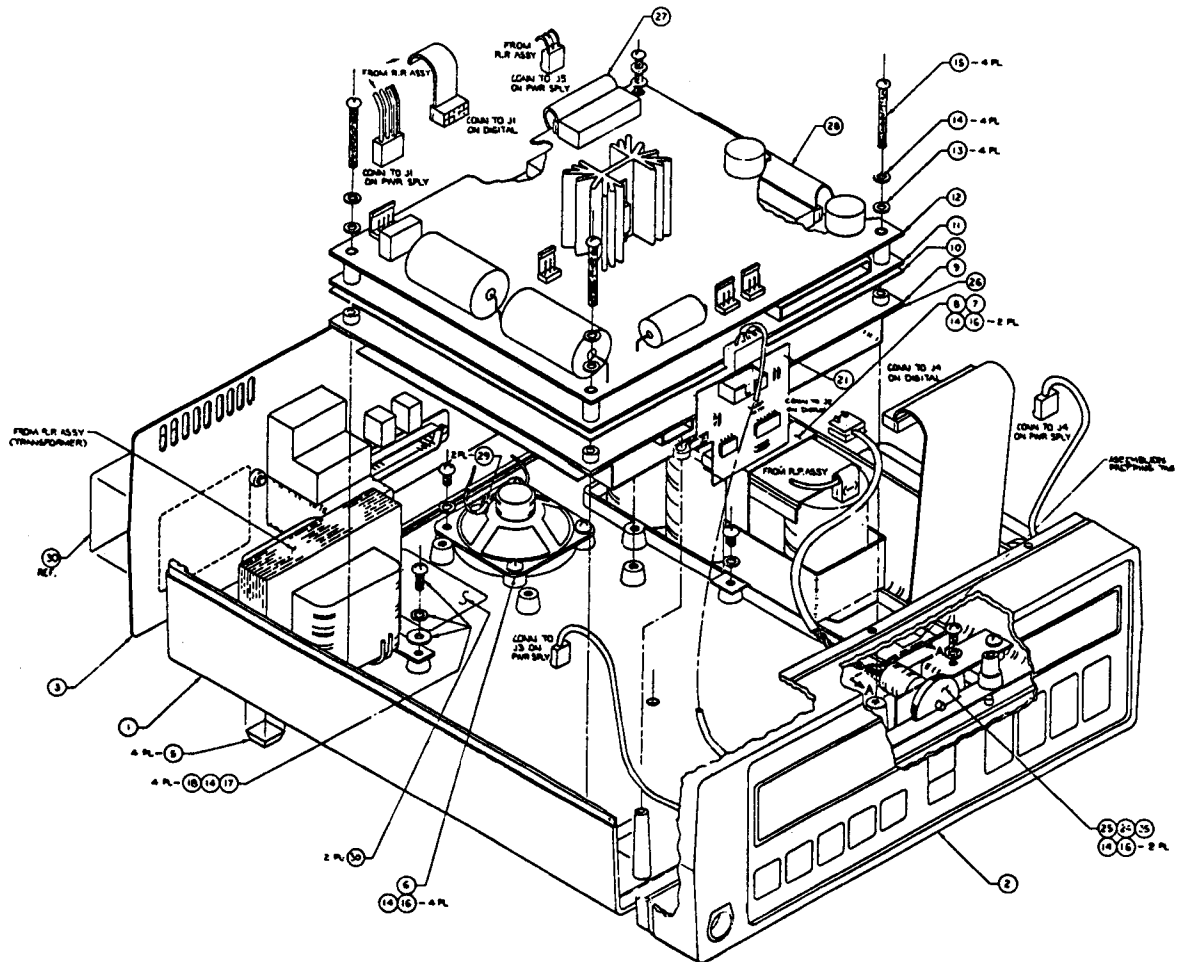

6.1.2 Oximeter assembly parts list

Two models of the unit exist (the upper and lower housings for these two versions are **not** interchangeable).

The older version has a handle that swings down to become a tilt stand or that can be used to hang the unit from a bed rail. You must order **Kit, housing, 3700/3700e, side handle (p/n 6050-0002-900)** to replace the housings for this model. The kit contains all the necessary parts to replace both housings, converting the unit to a side-handle version.

The newer version has a carrying handle on the side of the unit and a separate bail rod for tilting the unit. You may order the kit (6050-0002-900) to replace both housings, or you may order them separately as necessary from the parts list below.

Item #	Description	Part number
1	Housing, lower, 3700/3700e (side handle/bail rod model)	065- 6050-0002-825
2	Assy, front panel, 3700 (A1), top view	0380-0800-086
	Assy, front panel, 3700e (A1), top view	0380-0700-050
3	Assy, rear panel 3700 (A5)	0380-0800-021
	Assy, rear panel, 3700e (A5)	0380-0700-051
not shown	Handle strap (side handle model)	0380-1500-093
not shown	Handle end caps, white (side handle model)	0380-1500-118
not shown	Bail rod (side handle model)	0380-0100-283
not shown	Mounting foot, bail rod (side handle model)	0380-0100-284
5	Rubber foot, adhesive backed	0279-0109-300
6	Speaker, 8 Ω (SP1)	0279-0101-300
7	Battery strap	0279-0110-300
8	Battery, 8 volt (B1)	0279-0102-300
9	Assy, analog board (A2)	0279-0147-300
10	Shield plate	0279-0165-300
11	Assy, digital board, Rev M only 3700e German (A3)	0279-0150-300 0380-0500-068
11A	Assy, digital board, Rev P and above (A3) (SoftProbe/EasyProbe compatible)	0380-0500-018
12	Assy, power supply board (A4)	0279-0154-300
13	Washer, #6, flat, nylon	0380-0100-097
14	Washer, #6, internal star	0380-0100-094
15	Screw, #6-32 x 1.25", PPH	0380-0100-074
16	Screw, #6-32 x .25", PPH	0380-0100-067
17	Screw, #6-32 x .375", PPH	0380-0100-068
18	Washer, #6 flat	0380-0100-093
21	Assy, PCB, 30-bin upgrade	0380-0500-024
22	Case screw, #6-32 x 2.125", PPH (not shown)	0279-0103-300
not shown	Housing, upper, 3700/3700e (side handle/bail rod model)	6050-0002-823
24	Contrast adjust thumbwheel	0279-0116-300

6/Parts and Illustrations

Item #	Description	Part number
25	Bracket, thumbwheel	0279-0111-300
26	Shield plate	0279-0166-300
27	Assy, ribbon cable, 26 pin, 2.5"	0279-0105-300
28	Assy, ribbon cable, 60 pin, 2.5"	0279-0106-300
29	Shrink tubing, clear 1/8" dia.	
35	Cable assy., w/trimming pot, 3 cond, 12"	0279-0107-300
	Retainer, battery, 3 axis	0380-0100-257
	Label, Graphic display	0380-0900-064

6.1.3 Oximeter assembly service kits

Description	Part number
Kit, software only, revises to Rev. M only	0380-0800-044
Kit, current software only, for Rev. P or higher units	
English	6050-0003-139
French	6050-0003-140
German	6050-0003-141
Spanish	6050-0003-142
Kit, upgrade, current software and PCA, for pre-rev P units; upgrades to 30-bin and latest software	
English	6050-0003-224
French	6050-0003-225
German	6050-0003-222
Spanish	6050-0003-223
Kit, bottom view to top view, repl.	6050-0002-828
Kit, housing, 3700/3700e, side handle/bail rod model	6050-0002-900
Kit, display, TV, 30 bin upgrade (PCA, front panel, EPROM)	0380-0800-027
Front panel, Svc, 3700	0380-0800-086
Front panel, Svc, 3700e	0380-0700-050
Rear panel, Svc, 3700	0380-0800-121
Rear panel, Svc, 3700e	0380-0700-051

6.2 Front panel assembly

6.2.1 Front panel assembly illustration

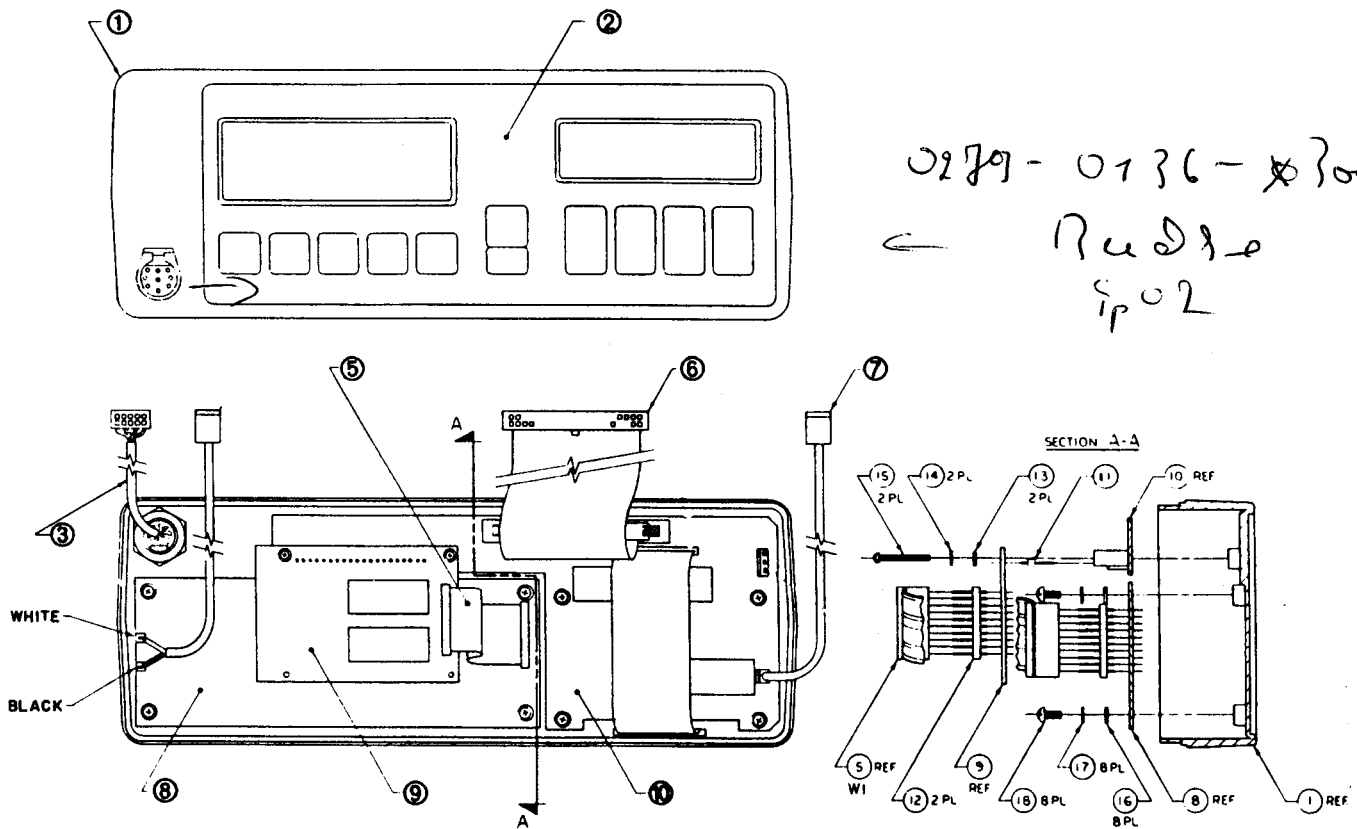

6.2.2 Front panel assembly parts list

Item #	Description	Part number
1 & 2	Assy, bezel, 3700, w/membrane	0380-0700-028
	Assy, bezel, 3700e, English, w/membrane	0380-0100-298
	Assy, bezel, 3700e, German, w/membrane	0380-0100-301
3	Cable assy, probe, black, Rev. M only	0279-0136-300
	Cable assy, probe, white, SoftProbe/EasyProbe, Rev. P and above	0380-0600-095
5	Assy, ribbon cable, 10 pin, 1 row	0279-0134-300
6	Assy, ribbon cable, 40 pin, 8"	0279-0133-300
7	A118-004, Rev V or lower only: Cable assy, 2 cond. shield, w/plugs	0279-0135-300
8	Display, LCD graphics, top view*	0380-0300-458
9	Graphic module interface	0279-0132-300
10	Assy, display board, top view* <i>Display Platine</i>	0279-0140-300
13	Washer, #2 flat, nylon	0279-0167-300
14	Washer, #2, internal star	0380-0100-088
15	Screw, #2-56 x .75, PPH	0380-0100-057
16	Washer, #4 flat, nylon	0380-0100-089
17	Washer, #4 internal star	0380-0100-090
18	Screw, #4-40 x .25, PPH	0380-0100-062

*Top view is for use in an oximeter (product code FMA or FMU) that the observer views from above the direct line of sight.

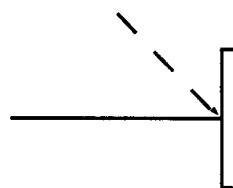

050-0002-828

Display Platine

A?

6.3 Rear panel assembly

6.3.1 3700 rear panel assembly illustration

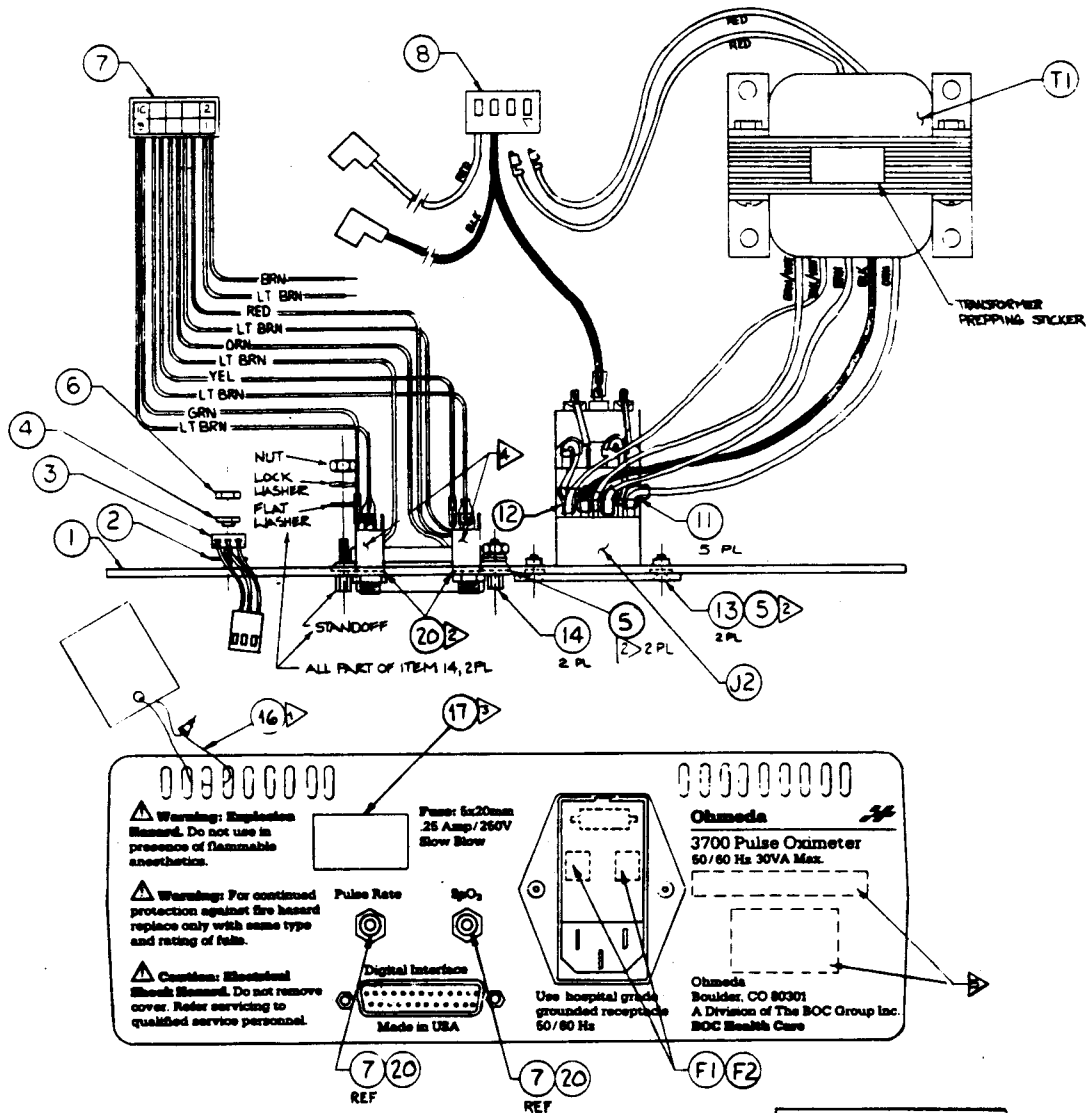

SHRINK TUBING CHART				
LOCATION	ITEM NO	DIA.	QTY	LENGTH
2-F	12	1/8"	1	1/2"
2-A, C, D, E	11	1/8"	5	1/2"

WIRE LIST		
FROM	COLOR	TO
T1	BRN/WHT	J8-D
T1	BLK/WHT	J8-F&H
Y1	BRN	J2
Y1	BLK	J2
Y1	GRN	J2
Y1	RED	J2-A
Y1	RED	B-1
Y1	RED	B-2
B-1	BLK	J2 - EARTH/GRD
B-2	BLK	-V BATT
B-3	RED	+V BATT
J8-F	WHITE	J2-H

6.3.2 3700e rear panel assembly illustration

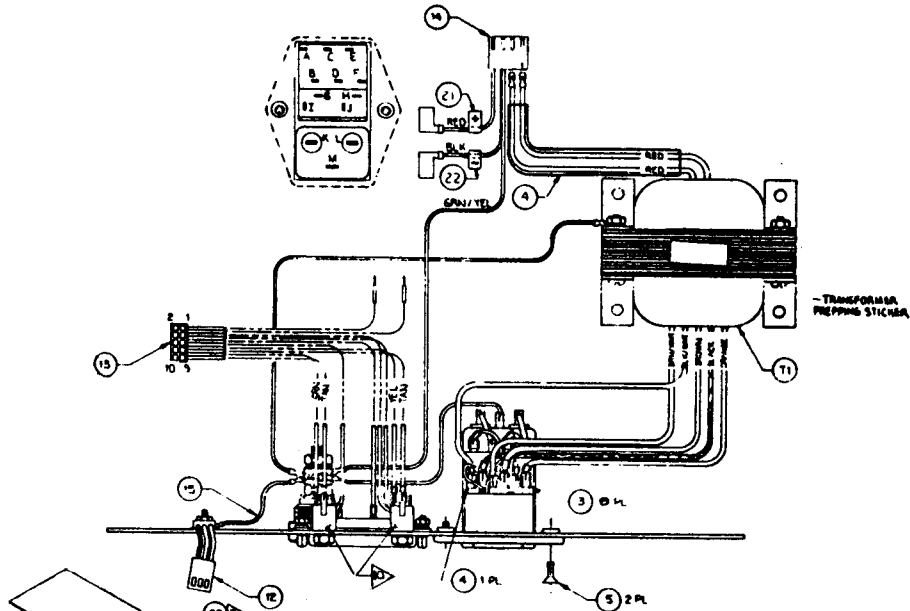

- TRANSFORMER PREPPING STICKER

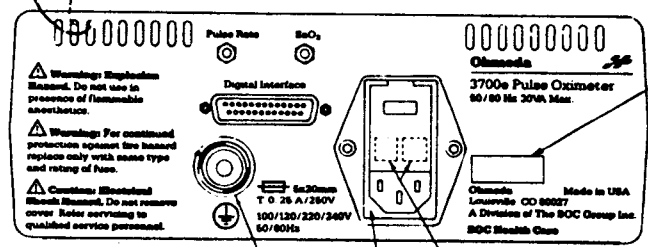

WIRE LIST				
FROM ITEM NO.	COLOR	TO ITEM NO.	TUBING ITEM NO.	LENGTH
T1	BROWN	J1-D	3	1/2"
T1	BLK/WHY	J1-F	4	1/2"
T1	BROWN	J1-C	3	1/2"
T1	BLACK	J1-E	3	1/2"
T1	ORANGE	J1-A	3	1/2"
T1	RED	14-1	---	---
T1	RED	14-2	---	---
J1-A1	GRN/BLK	15	---	---
J1-B	BLK/WHY	J1-D	5	1/2"
J1-H	SLDR	J1-F	4	1/2"
J1-S	GRN	J1-K	3	1/2"
J1-J	BLU	J1-L	3	1/2"

Digital interface

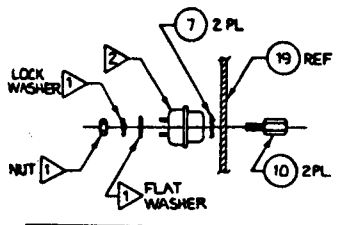

Analog output

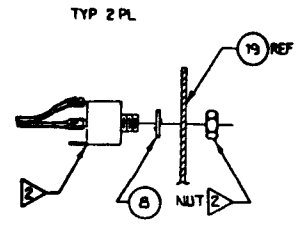

Voltage regulator

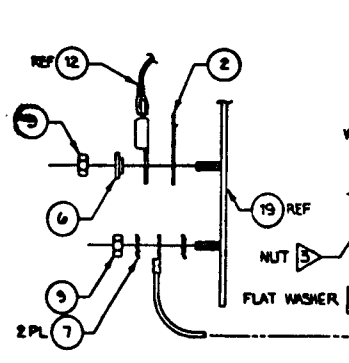

Ground equalization

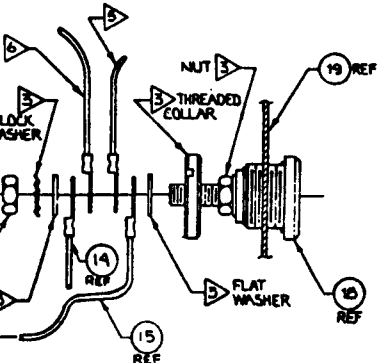

6.3.3 3700 rear panel assembly parts list

Item #	Description	Part number
1	Panel, rear, model 3700, English French	0380-0700-026 0380-0500-075
2	Thermal pad (3223-07FR-54)	0380-0100-041
3	Cable assy, regulator	0380-0600-083
4	Washer, insulating, shoulder	0380-0100-086
5	Washer, #4 external star	0380-0100-091
6	Nut, #4-40 hex	
7	Cable assy, output	0380-0600-077
8	Cable assy, battery 3700/3710	0380-0600-086
9	Pin, conn 18-22 AWG, box type	0279-0122-300
10	Wire, PVC stranded, 20 AWG, blk	
12	Shrink tubing, clear 1/4" dia.	
13	Screw, #4-40 x .375 soc flt blk	0380-0100-063
14	Screw lock assy	0380-0100-121
20	Washer, 1/4" internal lock	0380-0100-100
F1/F2	Fuse, .25 amp, 250V, Slow-blo	0279-0168-300
J2	Pwr line filter, w/volt select	0279-0117-300
T1	XFMR, MLT PRMY to 13.8 Vdc @1.5A	0380-1500-163

6.3.4 3700e rear panel assembly parts list

Item #	Description	Part number
1	Pin conn, 18-22 AWG, box type	0279-0122-300
2	Thermal pad (3223-07FR-54)	0380-0100-041
3	Shrink tubing, clear d" dia.	
4	Shrink tubing, clear c" dia.	
5	Screw, #4-40 soc flt blk	0380-0100-063
6	Washer, insulating, shoulder	0380-0100-086
7	Washer, #4 external star	0380-0100-091
8	Washer, 1/4" internal lock	0380-0100-100
9	Nut, #4-40 hex, 3/16 dr	
10	Screw lock assy.	0380-0100-121
12	Cable assy, regulator	0380-0600-083
13	Cable assy, output	0380-0600-077
14	Cable assy, battery int'l	0380-0600-117
15	Cable assy, rear panel, ground	0380-0600-118
18	Connector, ground equalization	0380-0100-308
19	Panel, rear 3700e, English German Spanish	0380-0700-043 0380-0700-056 6050-0002-456
20	Cable tie, 3"	0380-0100-116
F1/F2	Fuse, .25 amp, 250V, Slow-blo	0279-0168-300
J2	Pwr line filter, w/volt select	0380-0200-192
T1	XFMR, MLT PRMY to 13.8 Vdc @1.5A	0380-1500-163

6.4 Analog board assembly

6.4.1 Analog board assembly diagram

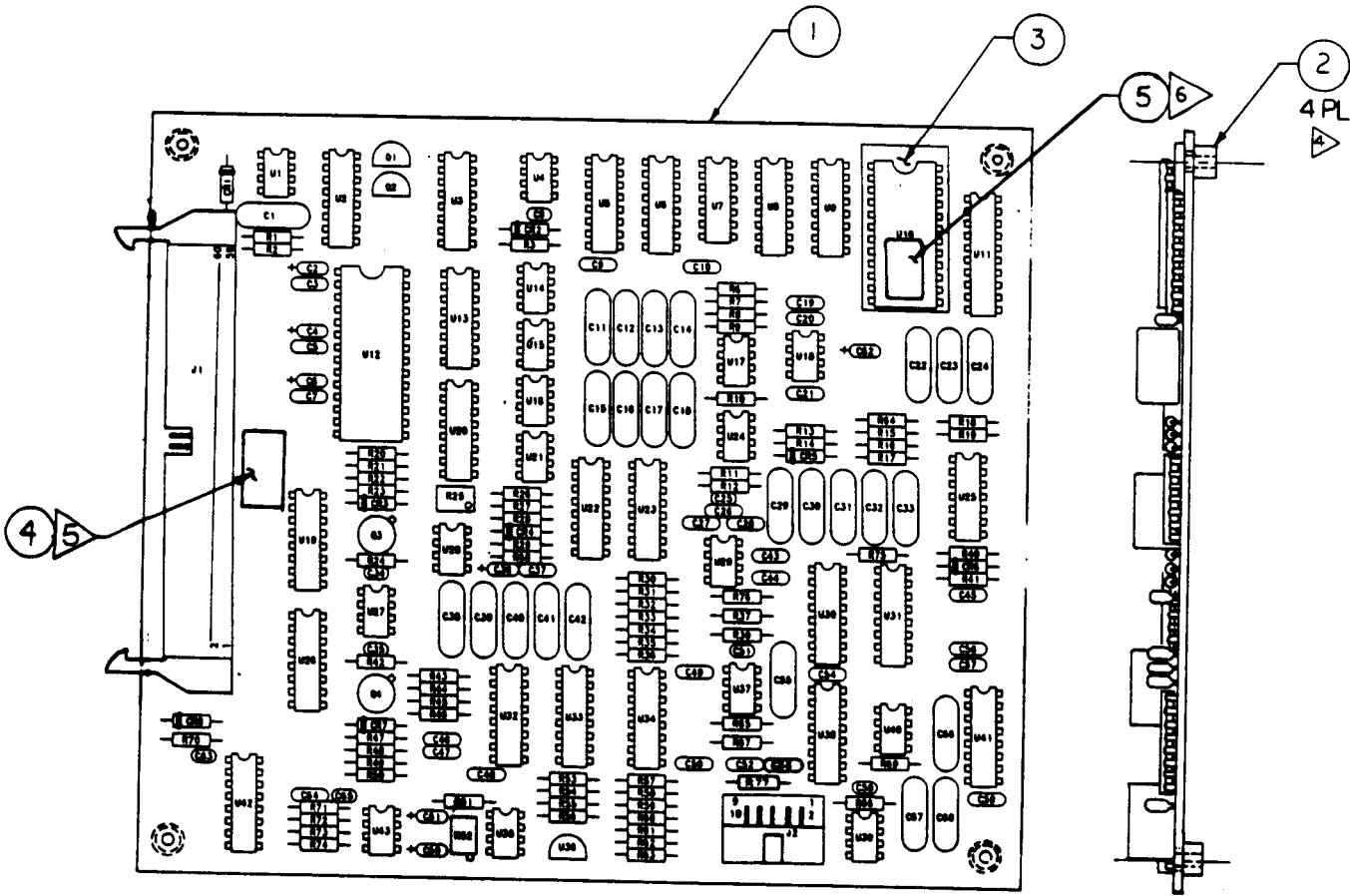

6.4.2 Analog board reference designators

Ref. designation	Description
Resistors	
R1, R2, R27	10K ¼W 1%
R3	20K ¼W 1%
R6, R8	40.2K ¼W 1%
R7, R9, R75, R76	562K ¼W 1%
R10	23.2K ¼W 1%
R11, R15, R16, R39, R58, R66	1M ¼W 1%
R12	215K ¼W 1%
R13, R14	150K ¼W 5%
R17, R44	2K ¼W 5%
R18	24K ¼W 5%
R19	3.9K ¼W 5%
R20, R21	49.9 Ω ¼W 1%

Ref. designation	Description
R22	16.5 Ω $\frac{1}{4}$ W 1%
R23, R47	33K $\frac{1}{4}$ W 5%
R24, R28, R42, R49, R50, R71	10K $\frac{1}{4}$ W 5%
R25	Pot, trimming, 1K Ω
R26	10.5K $\frac{1}{4}$ W 1%
R29	51K $\frac{1}{4}$ W 5%
R30, R61	30.9K $\frac{1}{4}$ W 1%
R31, R60	124K $\frac{1}{4}$ W 1%
R32, R63	61.9K $\frac{1}{4}$ W 1%
R33, R62	15.4K $\frac{1}{4}$ W 1%
R34	3.92K $\frac{1}{4}$ W 1%
R35	1.91K $\frac{1}{4}$ W 1%
R36	7.87K $\frac{1}{4}$ W 1%
R37, R69	21.5K $\frac{1}{4}$ W 1%
R40, R53, R54	50K 1/20W 1%
R41	4.75K $\frac{1}{4}$ W 1%
R43, R45, R46, R68, R72, R73	1K $\frac{1}{4}$ W 5%
R48	8.25 Ω $\frac{1}{4}$ W 1%
R51	75K $\frac{1}{4}$ W 1%
R52	Pot, trimming 10K Ω
R55	100K $\frac{1}{4}$ W 1%
R56	18K $\frac{1}{4}$ W 5%
R57	249K $\frac{1}{4}$ W 1%
R59	499K $\frac{1}{4}$ W 1%
R64, R70	100K $\frac{1}{4}$ W 5%
R65	10 Ω $\frac{1}{4}$ W 5%
R67	15 Ω $\frac{1}{4}$ W 5%
R74	5.11K $\frac{1}{8}$ W 1%
R77	392K $\frac{1}{4}$ W 1%
Capacitors	
C1, C12, C16	(Matched sets) 25V, 022 μ f tested
C2, C4, C6, C60, C61	Tant EL, 25V 20% 10 μ f
C3, C5, C7, C9, C10, C19, C20, C21, C26, C27, C28, C37, C43, C44, C45, C46, C47, C48, C49, C50, C52, C53, C54, C56, C57, C59, C64	MCER.20 50V 20% .1 μ F
C8	MCER 50V 5% 15pf
C11, C15	25V 5% .047 μ f
C13, C17, C32, C33	Polyester 63V .47 μ f
C14, C18, C30, C42, C66, C67, C68	Polyester 25V .22 μ f
C22, C23	Polyester 63V 5% .47 μ f
C24, C29, C31, C55	Polyester 25V 5% .22 μ f

6/Parts and Illustrations

Ref. designator	Description
C25, C51, C58	MCER 50V 5% .001 μ f
C34, C35	MCER 50V 5% 100pf
C36, C62	Tant EL 25V 20% 1 μ f
C38, C39, C40, C41	Polyester 100V 5% .1 μ f
C63	MCER 50V 5% .001 μ f
C65	MCER 50V 5% 470pf
Transistors	
Q1	VN0104N3, N-FET
Q2	VP010N3, P-FET
Q3, Q4	2N2222, NPN
Diodes	
CR1, CR2, CR3, CR4, CR7	1N6263
CR5, CR6, CR8	1N914
Integrated circuits	
U1, U4, U21	IC dual Jfet-Input op-amp 082C
U2, U3, U19, U26	IC CMOS 8-bit Mult DAC 7524
U5, U6	IC HCMOS decade counter divider 74HC4017
U7	IC HCMOS hex inverter, TTL THR 74HCT04
U8, U22, U30, U31, U32, U33, U38, U41, U42	IC CMOS triple 2-1 analog Mux 4053B
U9	IC HCMOS counter 14-it 74HC4020
U10	EPROM, sequence program 3700/3700e
U11	IC octal D-type flip-flop 74 HCT574
U12	IC A/D converter 12-bit 574
U13, U20, U23, U34	IC CMOS 8-to-1 analog Mux 4051B
U14, U16	IC mono sample and hold 398
U15, U27	IC dual op-amp LM358
U17, U18, U24, U29, U37, U40	IC ultra-low offset op-amp OP-07CP
U25	IC quad low power op-amp
U28, U39	IC mono JFET-input op-amp 356
U35	IC dual JFET-input op-amp 082B
U36	LM 385 B-1.2V
U43	IC JFET-input wide-band op-amp 357
Misc.	
Item 1	PCB, analog, 3700/3700e
Item 2	Standoff, .143 ID x .125 L
Item 3	Socket, 24-pin, Dip
Item 4	Label, .75" x .25"
Item 5	Label, EPROM sequence, 3700/3700e
J1	Header, 90 deg, lock, 4-wall, 60-pin
J2	Header, 90 deg, shrouded, 10-pin

6.4.3 Analog board schematic

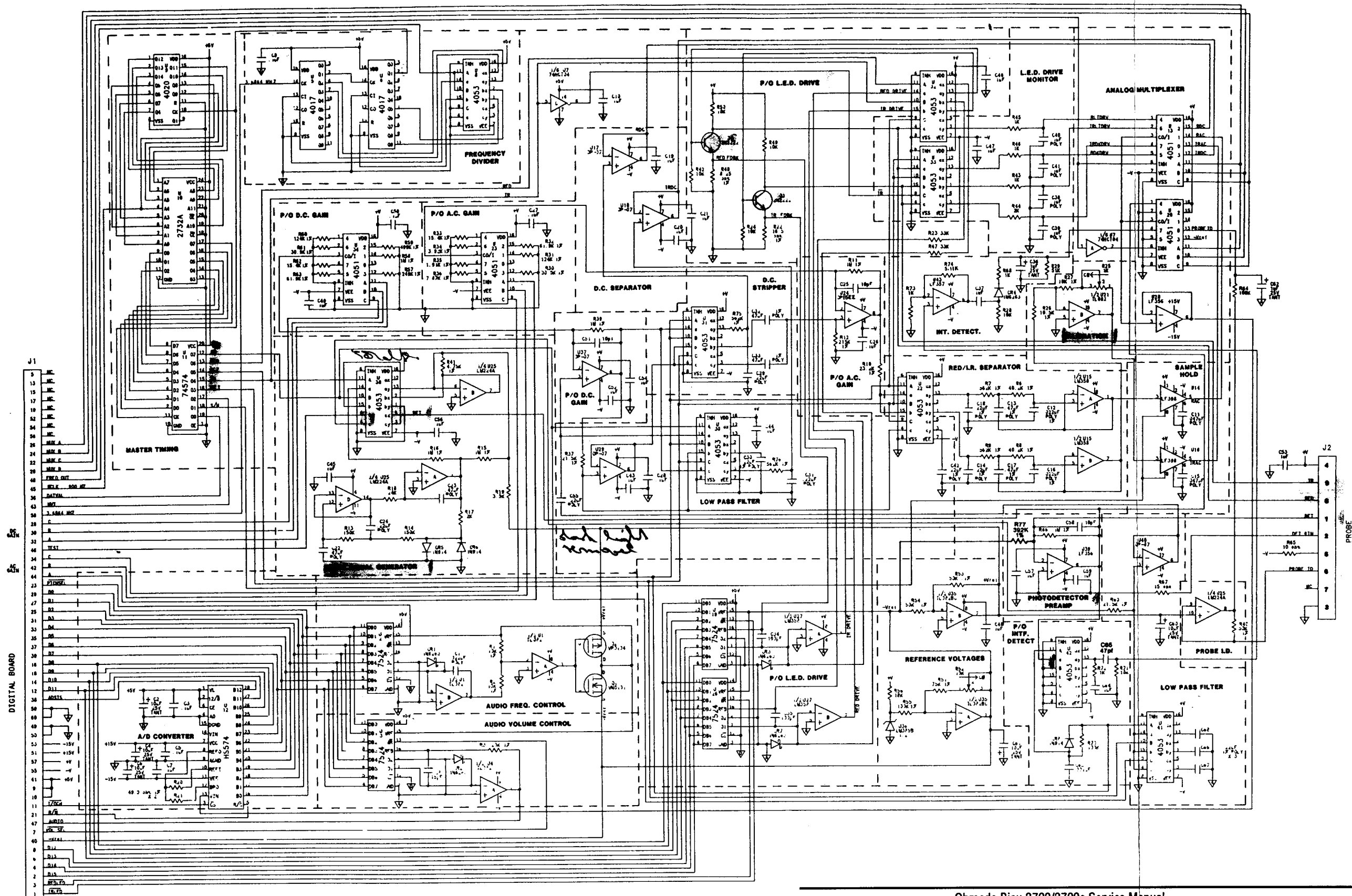

6.5 Digital board

6.5.1 Digital board diagram

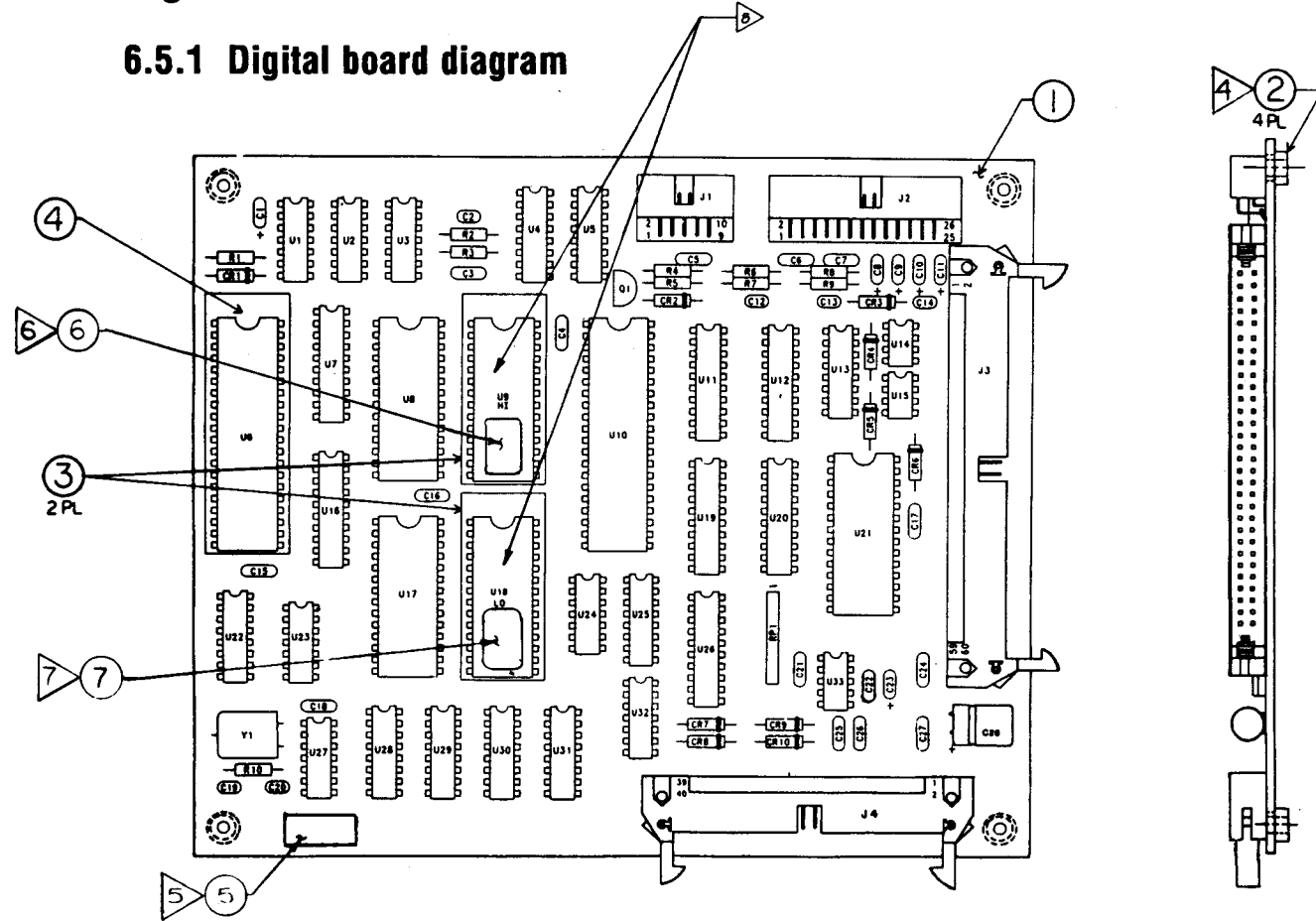

6.5.2 Digital board reference designators

Ref. designation	Description
Resistors	
R1	200K ¼W 5%
R2	100K ¼W 5%
R3	30K ¼W 5%
R4, R5	10K ¼W 5%
R6	100 Ω ¼W 5%
R7	1K ¼W 5%
R8, R9	300 Ω ¼W 5%
R10	15M ¼W 5%
RP1	R-Pak 10K x 7 (8-pin)
Capacitors	
C1	Tant EL 25V 20% 1.0µf
C2, C12	MCER 50V 5% .001µf
C3, C4, C5, C6, C7, C15, C16, C17, C18, C21, C22, C24, C25, C26, C27	MCER 50V 20% .1µf
C8, C9, C10, C11, C23	TANT EL 25V 20% 10.0µF
C13, C14	MCER 50V 5% 100pf

Ref. designator	Description
C19	MCER 50V 5% 22pf
C20	MCER 50V 5% 68pf
C28	Alum EL 25V Rad lead, 100µf
Transistor	
Q1	2N3904 NPN
Diodes	
CR1, CR2, CR3, CR7, CR8, CR9, CR10	1N914
CR4, CR5, CR6	1N6263
Integrated circuits	
U1	IC CMOS Q-2IN Nand Schmitt 4093B
U2	IC CMOS dual flip-flop 4013B
U3	IC HCMOS quad 2-input OR gate 74HC32
U4, U25	IC HCMOS counter 12-bit 74HC4040
U5	IC CMOS triple 2-1 analog Mux 4053B
U6	IC 16-bit Mos microprocessor Z8002
U7, U12, U16, U20	IC noninverting latch 74HCT573
U8, U17	IC CMOS RAM 8K x 8-bit, 6264
U9	EPROM, Hi, Model 3700/3700e
U10	IC CMOS UART 6402
U11, U19, U26	IC octal D-type flip-flop 74HCT574
U13	IC CMOS 8-bit mult DAC 7524
U14, U15	IC ultra-low offset op-amp op-07CP
U18	EPROM, Lo, Model 3700/3700e
U21	IC CMOS 10-bit mult DAC 7522
U22	IC HCMOS quad 2-1 data 74HCT157
U23	IC HCMOS hex inverter TTL THR 74 HCT04
U24	IC quad 2-input AND gate 74HC08
U27	IC HCMOS hex inverter unbuffered 74HCU04
U28	IC HCMOS dual 2-4 decode 74ICT139
U29, U30, U31	IC 1 of 8 decoder/demux 74HCT138
U32	IC HCMOS dual D flip-flop 74HC74
U33	IC current amplified LH0002C
Crystals	
Y1	3.6864 mHz
Misc.	
Item 1	PCB digital, 3700/3700e
Item 2	Standoff, .143 ID x .125 L
Item 3	Socket, 28-pin Dip
Item 4	Socket, 40-pin Dip
J1	Header, 90 deg shrouded 10-pin
J2	Header, 90 deg shrouded 26-pin
J3	Header, 90 deg lock, 4-wall, 60-pin
J4	Header, 90 deg lock, 4-wall, 40-pin

6.5.3 Digital board schematic

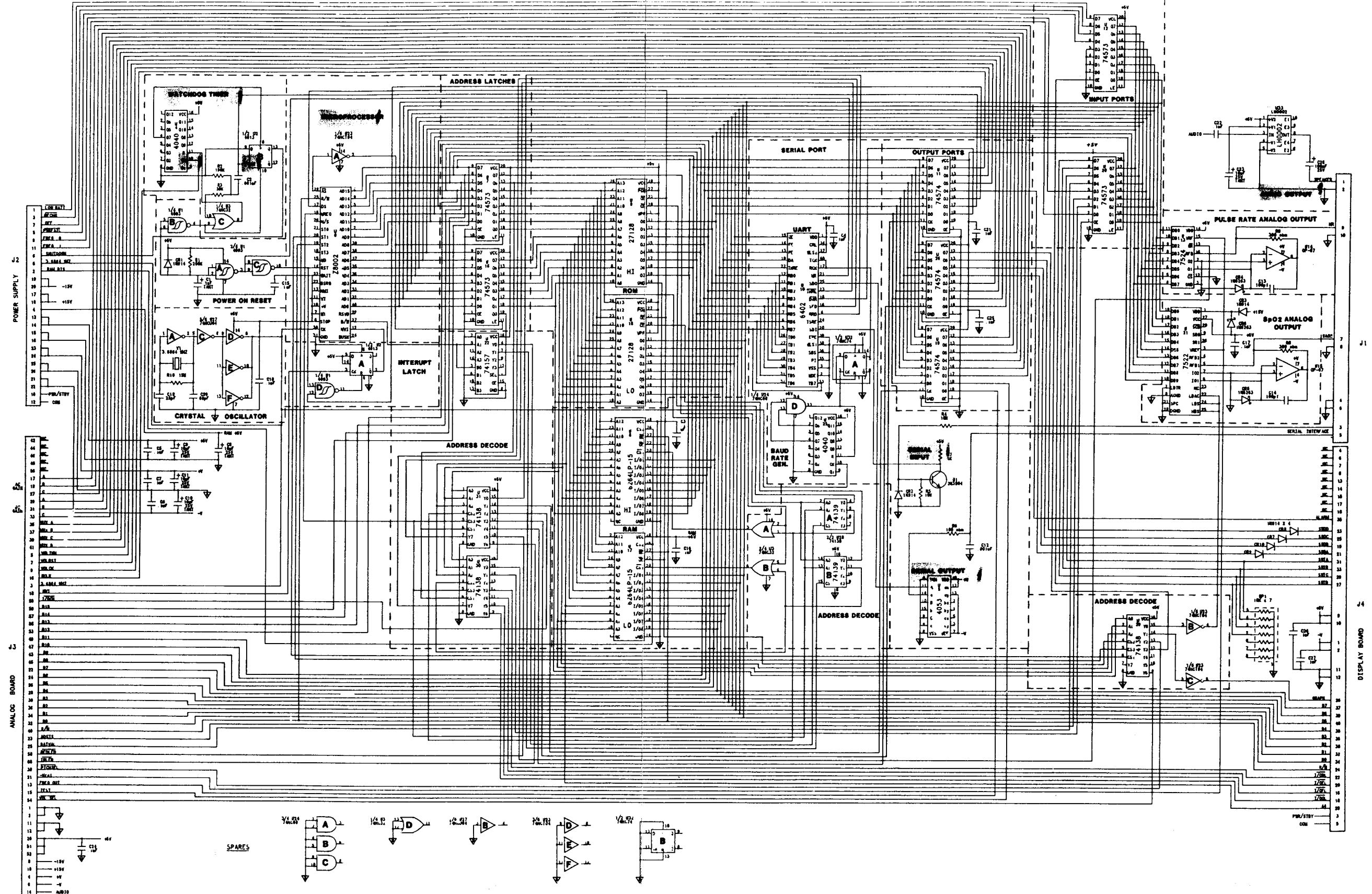

6.6 Display board assembly

6.6.1 Display board diagram

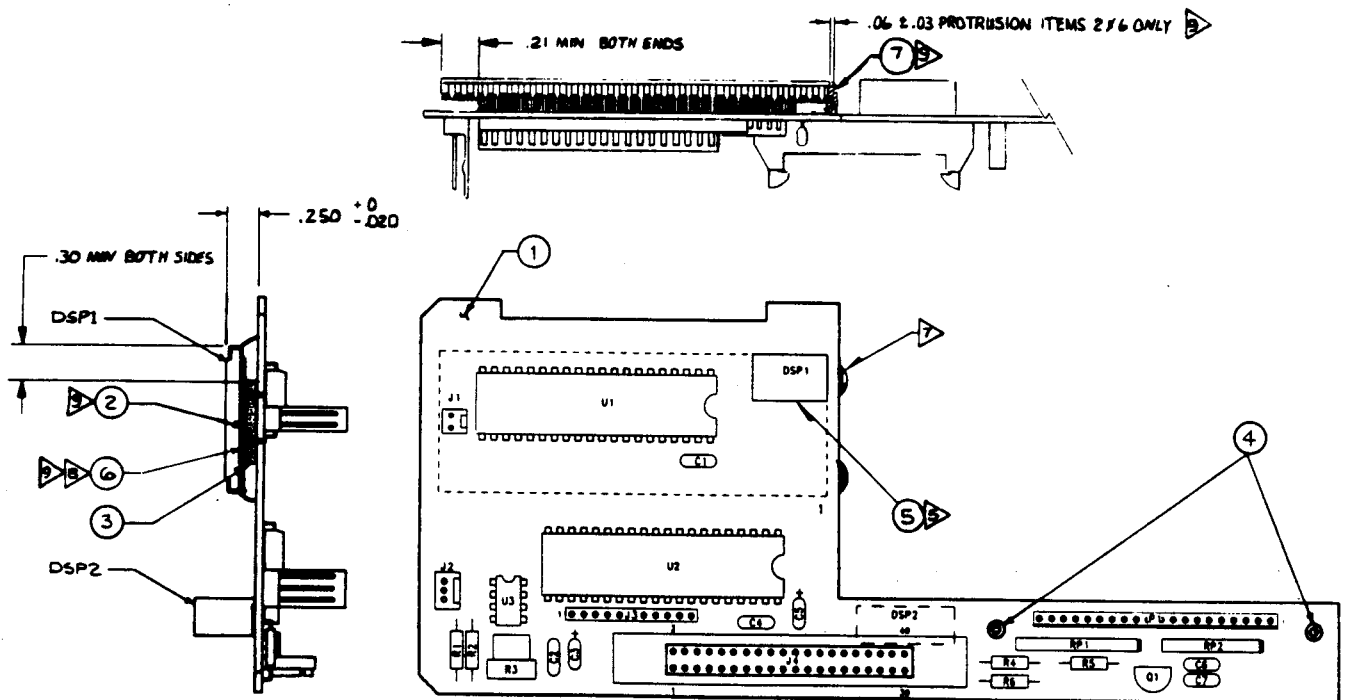

6.6.2 Display board reference designators

Ref. designator	Description
Resistors	
R1, R2	100K ¼W 5%
R3	Pot, trimming 50K Ω ¼ turn
R4	47 Ω ¼W 5%
R5	10K ¼W 5%
R6	150 Ω ¼W 5%
RP1	R-Pak, 100K x 9 (10-pin)
RP2	R-Pak, 100k x 7 (8-pin)
Capacitors	
C1, C2, C4, C6, C7	50V 20% .1µf
C3, C5	25V 20% 4.7 µf
Transistors	
Q1	VN0104N3, N-FET
Integrated circuits	
U1, U2	Display drive LCD 7232BF
U3	IC dual op-amp LM358
Displays	
DSP1	LCD display, top view
DSP2	Red LED, light bar

Ref. designator	Description
Misc.	
Item 1	PCB, display, 3700/3700e
Item 2	Panel, luminous/LED backlight, 3.15 x .98
Item 3	Foam spacer, display panel
Item 4	Standoff, .116 ID x .500 L
Item 5	Label, .75" x .25"
Item 6	Filter, display, yellow-green
Item 7	Adhesive, RTV, clear
J1	Header, straight locking, 2-pin
J2	Header, straight locking, 3-pin
J3	Header, straight, 11-pin
J4	Header, straight, lock 4-wall, 40-pin
P1	Socket, Sip connector 20-pin

6.6.3 Display board schematic

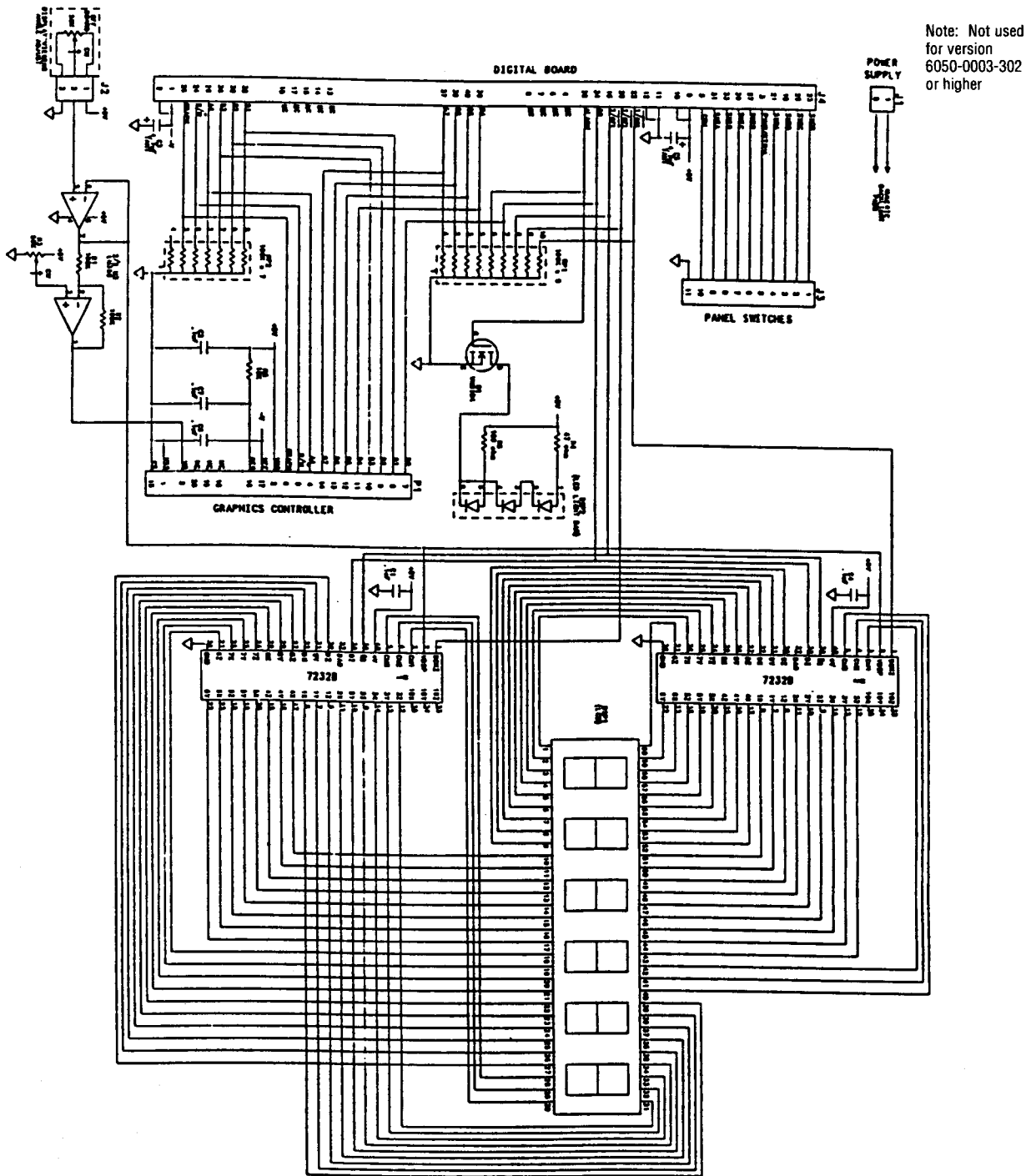

6.6.4 Membrane panel switch schematic

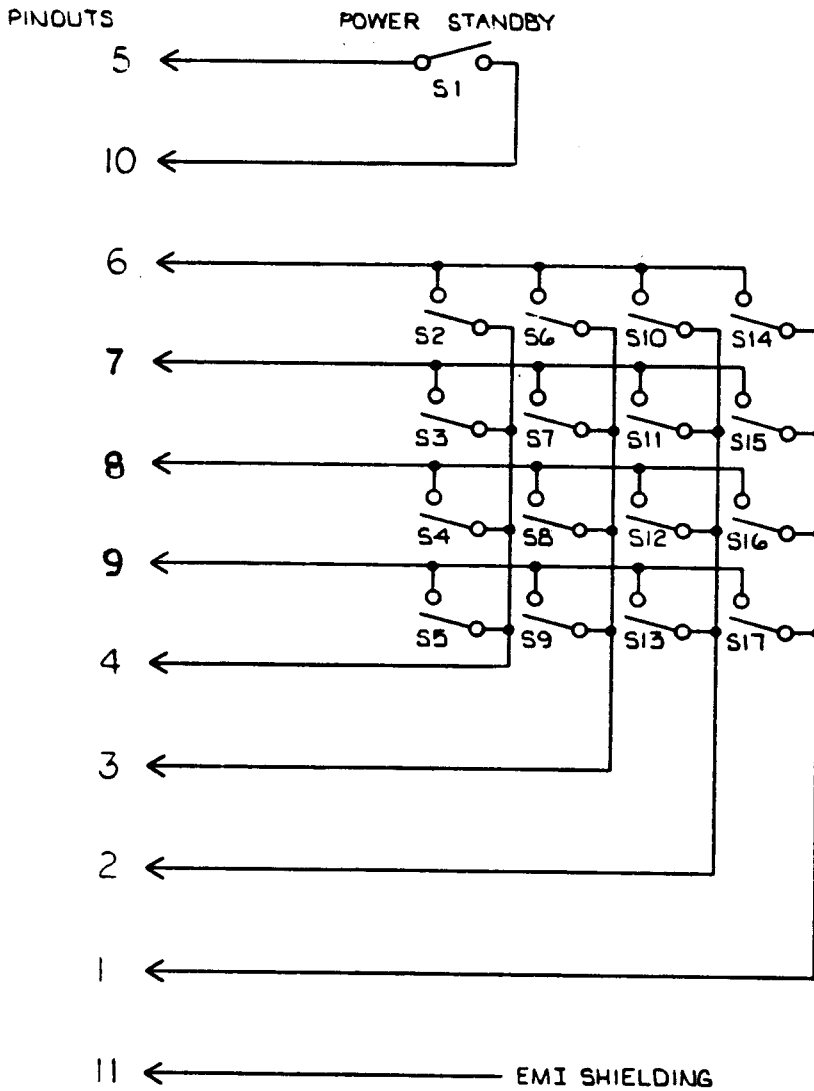

SWITCH	NOMENCLATURE
S1	POWER STANDBY
S5	ALARM VOLUME
S3	20/60 TREND
S4	PULSE VOLUME
S2	WAVE FORM
S6	ALARM
S13	△ LOW SpO2
S17	▽ LOW SpO2
S12	△ HIGH SpO2
S16	▽ HIGH SpO2
S11	△ LOW PULSE
S15	▽ LOW PULSE
S10	△ HIGH PULSE
S14	▽ HIGH PULSE
S7	_____
S8	_____
S9	_____

6.7 Power supply board

6.7.1 Power supply board diagram

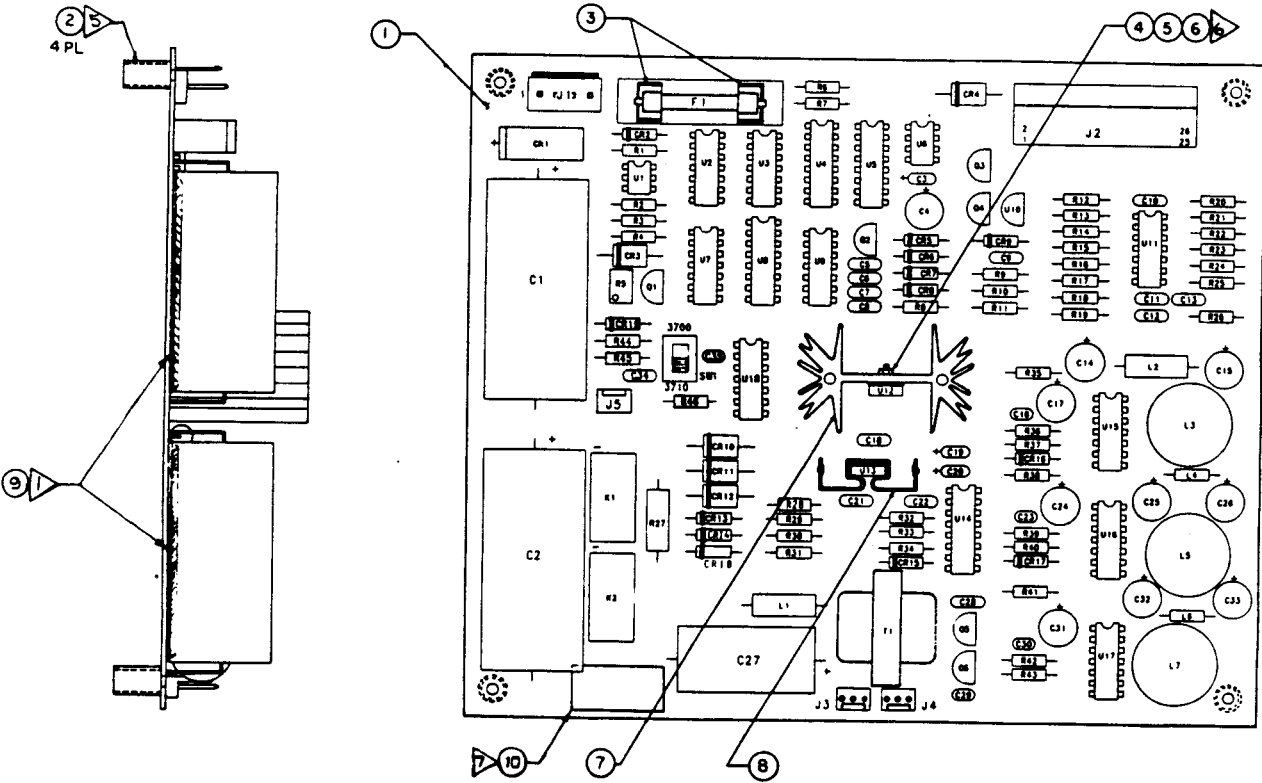

6.7.2 Power supply board reference designators

Ref. designator	Description
Resistors	
R1, R2	2K ¼W 5%
R3	243 Ω ¼W 1%
R4, R40, R42	1.40K ¼W 1%
R5	Pot, trimming, 500 Ω
R6	680K ¼W 5%
R7	330K ¼W 5%
R8, R12, R17, R18, R25, R28, R32, R34	100K ¼W 5%
R9, R10, R11, R29, R30, R45, R46	2M ¼W 5%
R13	46.4K ¼W 1%
R14	332K ¼W 1%
R15	69.8K ¼W 1%
R16	511 Ω ¼W 1%
R19	124K ¼W 1%

6/Parts and Illustrations

Ref. designator	Description
Resistors, cont'd	
R20	10.2K ¼W 1%
R21	49.9K ¼W 1%
R22	15K ¼W 1%
R23, R24	10M ¼W 5%
R26	267K ¼W 1%
R27	2.2 Ω 3W 1%
R31	10K ¼W 5%
R33	24K ¼W 5%
R35, R38, R41	1 Ω ½W 5%
R36	1.50K ¼W 1%
R37	4.75K ¼W 1%
R39, R43	16.2K ¼W 1%
R44	470K ¼W 5%
Capacitors	
C1, C2	Alum EL 25V +50-20% 4700µf
C3, C19, C20	Tant EL 25V 20% 10µf
C4, C14, C15, C17, C24, C25, C26, C31, C32, C33	Alum EL 25V, Rad lead, 100µf
C5, C6, C7, C8, C9, C11, C12, C13, C18, C21, C22, C28, C34	MCER 50V 20% .1µf
C10, C29	MCER 25V 20% .01µf
C16, C23, C30	MCER 50V 5% 220pf
C27	Alum EL 16V +50-20% 1000µf
C35	MCER, 50V 5% .001µf
Transistors	
Q1, Q2, Q3, Q4, Q5	VN0104N3, N-FET
Q6	VN0206N3 N-FET
Relays	
K1, K2	9V, DPDT 2 amp
Fuses	
F1	2 amp, fast-act, instrumentation
Diodes	
CR1	Rectifier, 3N254, full wave bridge, 100V
CR2, CR5, CR6, CR7, CR8, CR15, CR18	1N914
CR3, CR10, CR11, CR12	1N5820 3amp Schottky
CR4	Transzorb P6KE6.8
CR9, CR16, CR17	1N5817 1 amp Schottky
CR13, CR14, CR19	1N4001 50V 1 amp
Integrated circuits	
U1	255 Optoisolator
U2, U7, U18	IC CMOS quad 2-input Nand Schmitt 409
U3, U9	IC CMOS dual D flip-flop 4013B
U4	IC CMOS dual binary counter 4520B
U5, U14	IC HCMOS ounter 14-bit 74HC4020
U6	IC CMOS POS volt regulator 7663
U8	IC CMOS hex interting buff 4049UB
U10	IC voltage reference 1.235V LM385
U11	IC quad differential comp 339
U12, U13	IC 3 term +5 volt regulator 7805

Ref. designator	Description
Integrated circuits, cont'd	
U15, U16, U17	IC switching volt regulator 497
Misc.	
Item 1	PCB, power supply, 3700/3700e
Item 2	Standoff, .143 ID x .50 L
Item 3	Fuse clip, 1/4"
Item 4	Screw, #6-32 x .375 steel round nylon
Item 5	Thermal pad (3223-07FR-54) Berquist
Item 6	Nut, #6-32 hex nylon
Item 7	Heat sink, TO-220, 3.9 deg C/W
Item 8	Heat sink, TO-220, 20 deg C/W
Item 9	Adhesive, RTV, clear
Item 10	Label, .75" x .25"

6.7.3 Power supply board schematic

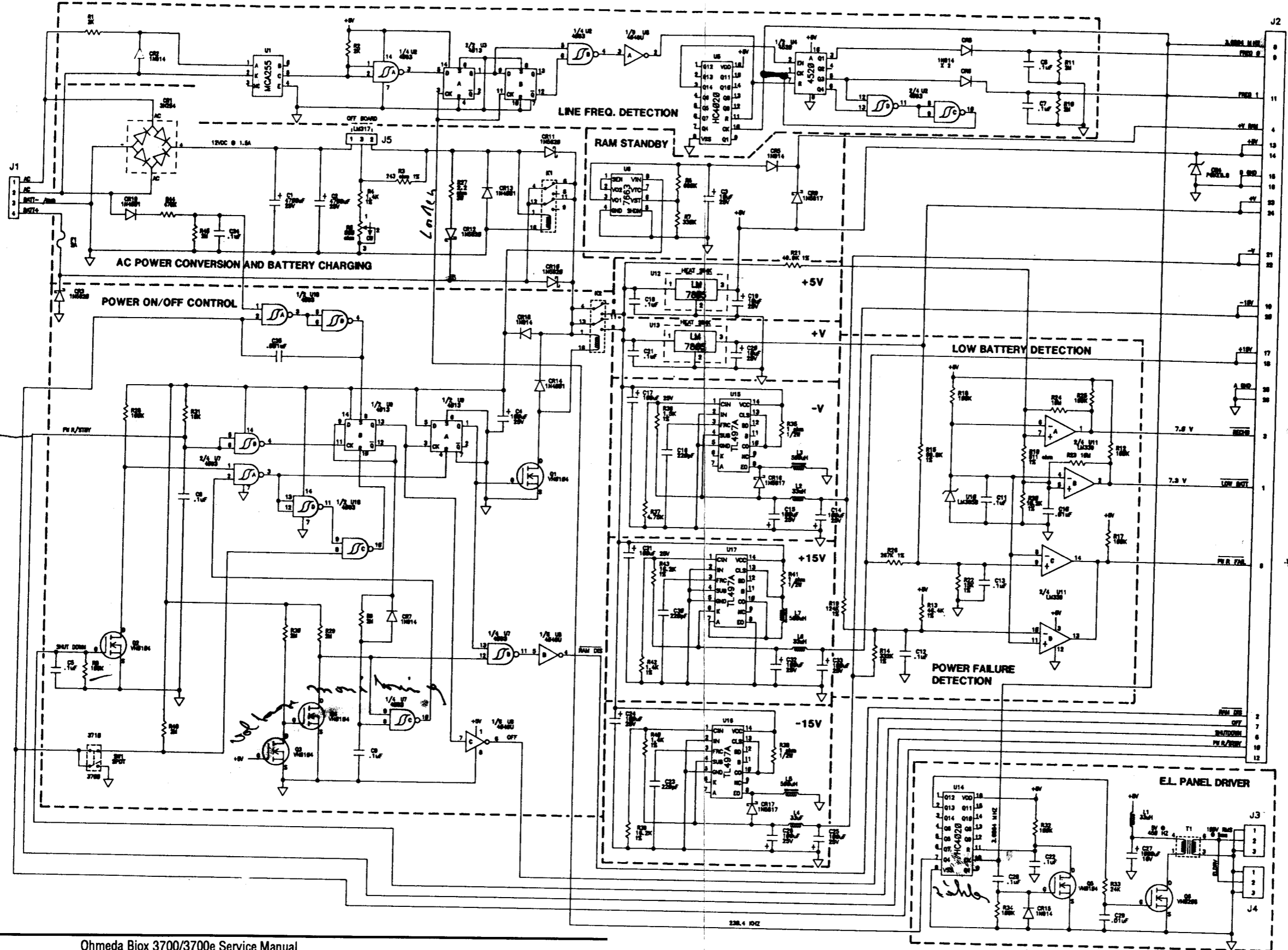

*RB Murdock
www.ty1.com
murdock!*

*0-6
-6
065
1.23*

6.8 Interface board

6.8.1 Interface board diagram

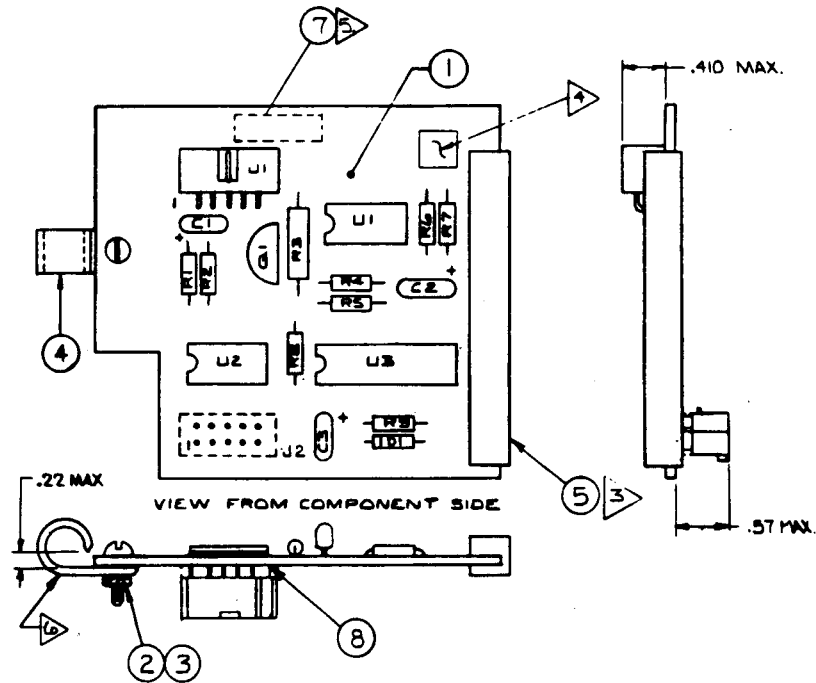

6.8.2 Interface board reference designators

Ref. designator	Description
Resistors	
R1, R4	2K 1/8W 1%
R2, R8	590K 1/8W 1%
R3	2 Ω 1W 1%
R5, R7	10K 1/8W 1%
R6	20K 1/8W 1%
R9	200K 1/8W 5%
Capacitors	
C1, C3	Tant EL 25V 20% 10μf
C2	MCER 50V 20% .1μf
Transistors	
Q1	VN0206N3 N-FET
Diodes	
D11	N914
Integrated circuits	
U1	IC low power comparator LM393N
U2	Op-amp ICL7612
U3	HCMOS dual D-type flip-flop 74HC74

Ref. designator	Description
Misc.	
Item 1	PCB, upgrade interface board
Item 2	Screw, #6-32 x .375 Steel round nylon
Item 3	Nut, #6-32 hex nylon
Item 4	Cable clamp, 5/16" nylon
Item 5	Extrusion, rubber
Item 6	Adhesive, RTV, clear
Item 8	Spacer, connector, 10-pin
J1	Header, 90 deg shrouded, 10-pin
J2	Socket, 10-pin, center key

6.8.3 Interface board schematic

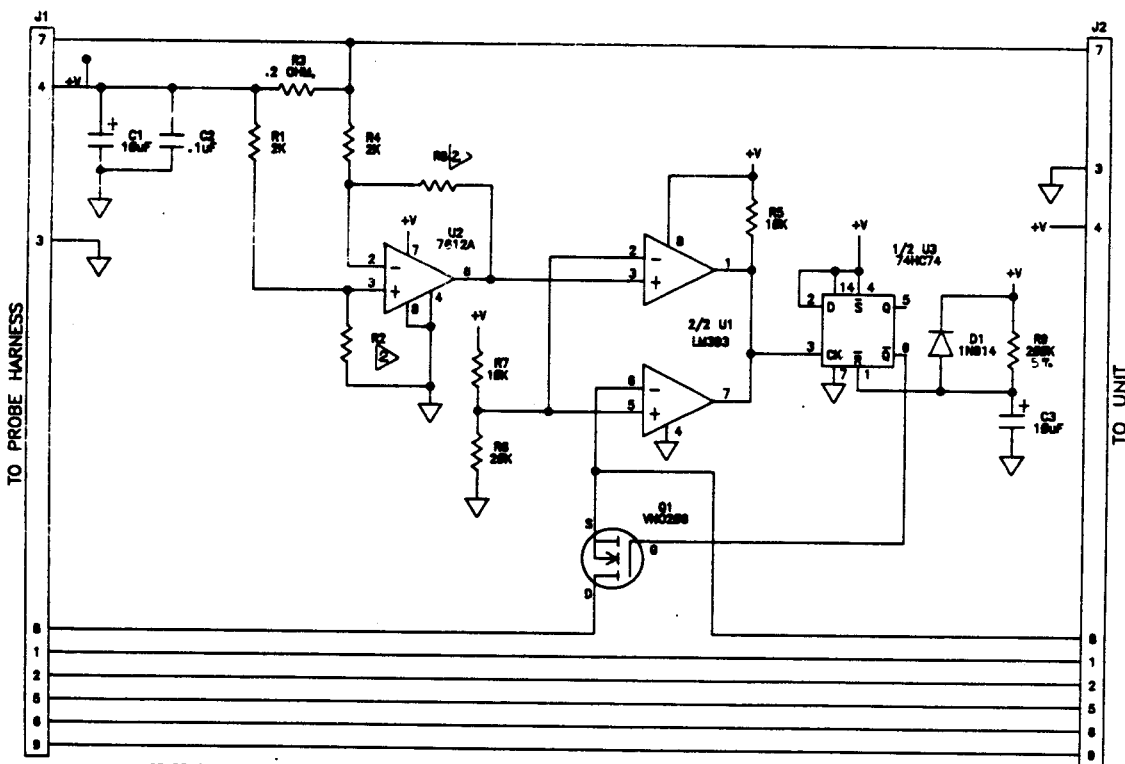

SPARE GATES

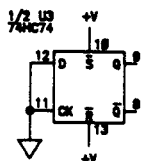

NOTE: 1. ALL RESISTORS ARE 1/8W, 1% UNLESS OTHERWISE NOTED.

Ohmeda
1315 West Century Drive
Louisville CO 80027 9560 USA
303 666 7001



THE BOC GROUP

Regional Service Offices

US and Canada Eastern Region

Ohmeda
450 Raritan Center Pkwy
Raritan Center
Edison NJ 08837 USA
Tel 800 345 2755
Fax 908 225 2189

Midwestern and Southeastern Region

Ohmeda
7750 The Bluffs NW
Austell GA 30001 USA
Tel 800 345 2755
Fax 404 944 1382

Western Region

Ohmeda
616 Six Flags Dr Suite 310
Arlington TX 76011 USA
Tel 800 345 2755
Fax 817 633 6235

Service and Distribution Center

Ohmeda
7750 The Bluffs NW
Austell GA 30001 USA
Tel 800 345 2755
Tel 404 739 4774
Fax 404 739 4770

Technical Support

Ohmeda
Ohmeda Drive
PO Box 7550
Madison WI 53707 7550 USA
Tel 800 345 2755
Fax 608 222 9147

Canada Service Centre

Ohmeda
5865 McLaughlin Road
Mississauga Ont L5R 1B8
Canada
Tel 905 568 9533
Fax 905 568 9799

International Offices UK, Europe, Africa, and Middle East

Ohmeda
Ohmeda House
71 Great North Road
Hatfield Hertfordshire
AL9 5EN England
Tel 0707 263570
UK Telex 918179
Int'l Telex 915128
UK Fax 0707 260065
Int'l Fax 0707 260191

France

Ohmeda
Parc de Pissaloup BP 10
8 Avenue Jean d'Alembert
78190 Trappes
France
Tel 33 1 30 68 60 00
Fax 33 1 30 68 60 01

Germany, Central Europe

Ohmeda GmbH & Co KG
Langemarckplatz 3
Postfach 2880
D-8520 Erlangen
Deutschland
Tel 49 91 31 81 01 0
Fax 49 91 31 81 01 11

Italy

Ohmeda Milano
Via Carpaccio 33
20090 Trezzano S/N (MI)
Italia
Tel 02 445761
Telex 314479 I
Fax 02 445 5614

Netherlands

Ohmeda BV
Rembrandtlaan 1A
3723 BG Bilthoven
Netherlands
Tel 31 30 289 399
Fax 3130 284 867

Spain

Ohmeda Madrid
C/Manuel Tovar 26
28034 Madrid
España
Tel 91 358 16 76
Telex 23795 Mameq E
Fax 91 358 12 84

Sweden & Scandanavia

BOC Ohmeda AB
Nordic
PO BOX 631
Ostra Sandgatan 12
S 251 06 Helsingborg
Sweden
Tel 46 42 178800
Fax 46 42 178747

Japan

Service

Ohmeda & NEC San-ei, Ltd
Technical Center
No. 21 Maru YA Bldg.
2 16 11 Kaname-cho
Toshima-ku Tokyo
171 Japan
Tel 03 3973 4055
Fax 03 3973 9102

Sales and Marketing

Ohmeda & NEC San-ei, Ltd
Showa Shiba Park Bldg. A
2-4-1 Shiba Koen
Minato-ku Tokyo
105 Japan
Tel 03 5470 6789
Telex 232 3106
Fax 03 5470 6781

Asia/Pacific

Ohmeda
No 198 Yishun Avenue 7
Singapore 2776
Tel 65 753 6311
Fax 65 753 1817

Latin America and Caribbean

Ohmeda
9200 S Dadeland Blvd
Suite 610
Miami FL 33156 USA
Tel 305 670 9938
Fax 305 670 4834

For additional information or to place an order in the USA, call 800 345 2700.